

sinamics



 SINAMICS S120
Drive System
0.12 kW to 1200 kW

SIEMENS

Related catalogs

SINAMICS G110 D 11.1
Inverter Chassis Units
0.12 kW to 3 kW
Order No.:
E86060-K5511-A111-A2 (German)
E86060-K5511-A111-A2-7600 (English)



SINAMICS G130 D 11
Drive Converter Chassis Units
SINAMICS G150
Drive Converter Cabinet Units
Order No.:
E86060-K5511-A101-A3 (German)
E86060-K5511-A101-A3-7600 (English)



SINAMICS S150 D 21.3
Drive Converter Cabinet Units
75 kW to 1200 kW
Order No.:
E86060-K5521-A131-A1 (German)
E86060-K5521-A131-A1-7600 (English)



SINUMERIK & SINAMICS NC 61
Automation Systems for
Machine Tools
Order No.:
E86060-K4461-A101-A1 (German)
E86060-K4461-A101-A1-7600 (English)



SIMOTION PM 10
Motion Control System
Order No.:
E86060-K4910-A101-A5 (German)
E86060-K4910-A101-A5-7600 (English)



SIMATIC ST 70
Products for Totally Integrated
Automation and Micro Automation
Order No.:
E86060-K4670-A101-B1 (German)
E86060-K4670-A101-B1-7600 (English)



SITRAIN ITC
Training for Automation and
Industrial Solutions
Order No.:
Paper: E86060-K6850-A101-B6 (German)
E86060-K6850-A101-B6-7600 (English)
CD-ROM: E86060-D6850-A100-C4-7400



Catalog CA 01 CA 01
The Offline Mall of Automation and Drives
Order No.:
CD-ROM: E86060-D4001-A100-C4 (German)
CD-ROM: E86060-D4001-A110-C4-7600 (English)
DVD: E86060-D4001-A500-C4 (German)
DVD: E86060-D4001-A510-C4-7600 (English)



A&D Mall

Internet:
<http://www.siemens.com/automation/mall>



SINAMICS MICROMASTER SIZER configuration tool

SIZER speeds up and simplifies the configuration of **SINAMICS G110, SINAMICS G130, SINAMICS G150, SINAMICS S120, SINAMICS S150** and **MICROMASTER 4** drives.

The tool will support you during the technical configuration of all components required to complete a drive task. SIZER will guide you through all stages of the configuration process, from the line supply through the drive components and beyond to the motors.

Motors are configured by means of standardized load characteristics, cyclic drives or free duty cycles. The drive components required (e.g. power units, power supplies) are calculated. The configuration completes the drive system by adding the supplementary components (e.g. Sensor Modules, Terminal Expansion Modules, cables, reactors, filters).

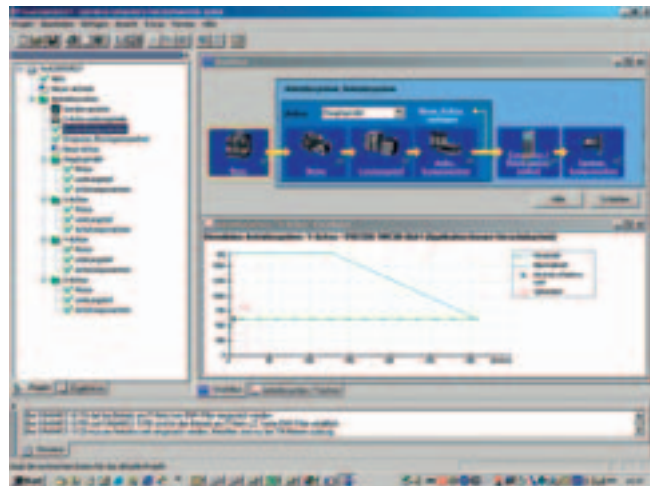

Menu driven configuration makes it easier for beginners to use the tool. Status information keeps you continually informed of the progress of the configuration process. The online help provides support during configuration. In addition to the data calculated, characteristics are also displayed to assist optimization and highlight reserves.

The export function can be used to forward the parts list to the SAP-VSR ordering system where available.

Minimum hardware and software requirements

PG or PC with Pentium™ II 400 MHz (Windows™ 2000), Pentium™ III 500 MHz (Windows™ XP)

256 MB RAM (recommended 512 MB RAM)

At least 990 MB of free hard disk space

An additional 100 MB of free hard disk space on Windows system drive

Monitor resolution 1024 x 768 pixels

Windows™ 2000 SP2, XP Professional SP1,

XP Home Edition SP1

Microsoft Internet Explorer 5.5 SP2

Use

The SINAMICS MICROMASTER SIZER can be used free of charge. A minimal fee is charged for processing CD delivery.

The user interface is available in English and German.

The SINAMICS MICROMASTER SIZER configuration tool can be ordered from your Siemens representative under Order No. **6SL3070-0AA00-0AG0**.

SINAMICS S120 Drive System 0.12 kW to 1200 kW

Catalog D 21.1 · 2006

Supersedes:
Catalog D 21.1 · 2005
Catalog D 21.2 · April 2004

The products contained in this catalog are also part of the CA 01 Catalog
Order No.:
E86060-D4001-A110-C4-7600 (CD-ROM)
E86060-D4001-A510-C4-7600 (DVD)

Please contact your Siemens branch office for further information

© Siemens AG 2006



The products and systems described in this catalog are produced/distributed in accordance with the requirements of a quality management system which has been certified to DIN EN ISO 9001 (Certificate Registration No. 001258 QM) and DIN EN ISO 14001 (Certificate Registration No. 081342 UM). The certificate is recognized by all IQNet



	Introduction	Welcome to Automation and Drives Totally Integrated Automation SINAMICS SINAMICS S120	1
Drive system	SINAMICS S120	System overview Communication Engineering Software Control Units Power Modules Line Modules, Motor Modules System components	2
Motors	AC motors	Synchronous motors Geared motors Asynchronous (induction) motors Dimension drawings	3
Supplementary components	SIMODRIVE sensor measuring systems	Optoelectronic rotary encoders Hollow-shaft measuring system	4
	MOTION-CONNECT Connection system	Power cables Signal cables Length code	5
Additional information	System description	SIZER configuration tool Configuration	6
	Services and documentation	Applications Training Service & Support Documentation	7
	Appendix	Glossary Siemens contacts worldwide A&D online services Index Terms and conditions of sale and delivery Export regulations	8

Welcome to Automation and Drives

We would like to welcome you to Automation and Drives and our comprehensive range of products, systems, solutions and services for production and process automation and building technology worldwide.

With Totally Integrated Automation and Totally Integrated Power, we deliver solution platforms based on standards that offer you a considerable savings potential.

Discover the world of our technology now. If you need more detailed information, please contact one of your regional Siemens partners.

They will be glad to assist you.





Totally Integrated Automation – innovations for more productivity

With the launch of Totally Integrated Automation, we were the first ones on the market to consistently implement the trend from equipment to an integrated automation solution, and have continuously improved the system ever since. Whether your industry is process- and production-oriented or a hybrid, Totally Integrated Automation is a unique "common solution" platform that covers all the sectors. Totally Integrated Automation is an integrated platform for the entire production line - from receiving to technical processing

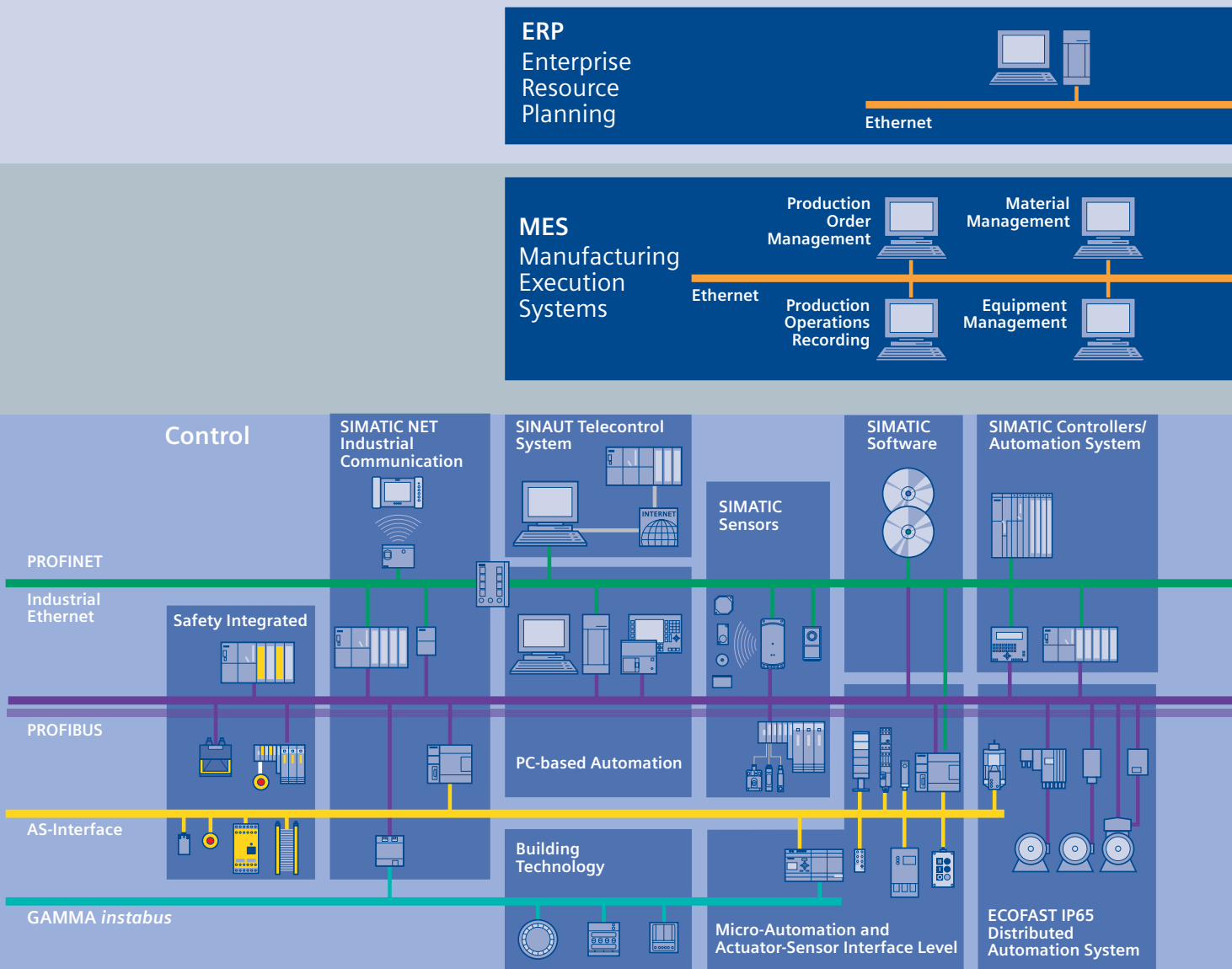

and production areas to shipping. Thanks to the system-oriented engineering environment, integrated, open communications as well as intelligent diagnostics options, your plant now benefits in every phase of the life cycle.

In fact, to this day we are the only company worldwide that can offer a control system based on an integrated platform for both the production and process industry.

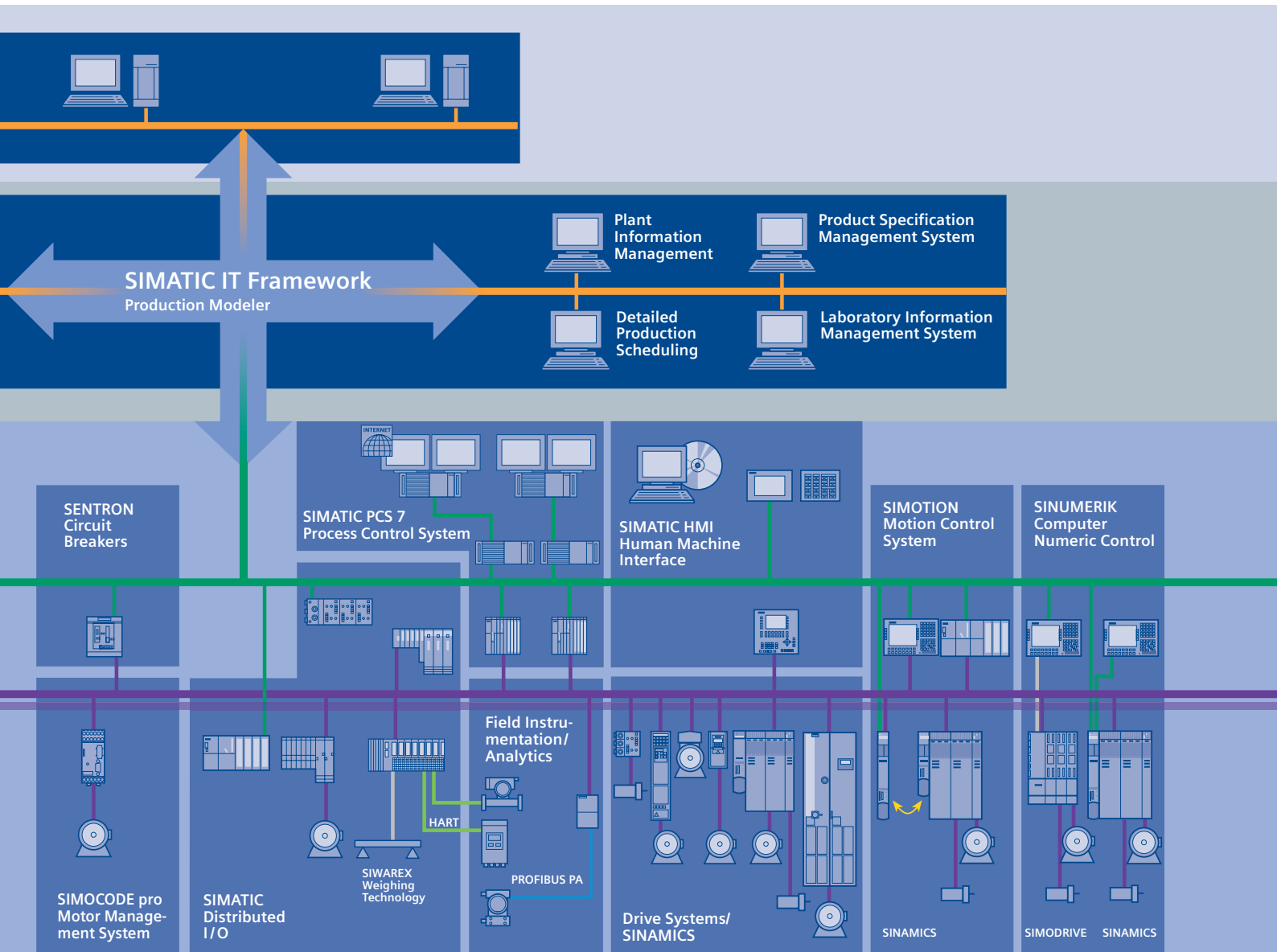

The SINAMICS drive family

SINAMICS G



Mixer/mills



Pumps/fans/
compressors



Conveyor systems



Extrusion

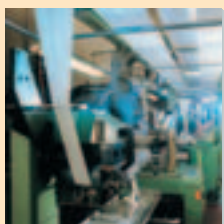

Textiles



Metal forming
technology



Woodworking

SINAMICS S

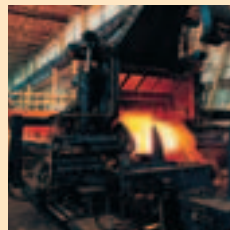

Rolling mills

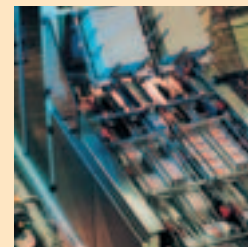

Packaging



Machine tools

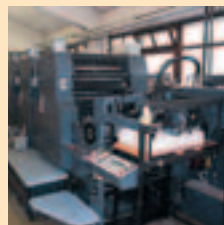

Printing and paper
machines

G_D211_EN_00137

Application areas of the SINAMICS drive family

Application

SINAMICS is the new family of Siemens drives designed for machine and plant engineering applications. SINAMICS offers solutions for all drive tasks:

- Simple pump and fan applications in the process industry
- Applied single drives in centrifuges, presses, extruders, elevators, as well as conveyor and transport systems
- Drive line-ups in textile, plastic film, and paper machines, as well as in rolling mill plants
- Highly dynamic servo drives for machine tools, as well as packaging and printing machines

Versions

Depending on the application, the SINAMICS range offers the ideal variant for any drive task.

- SINAMICS G is designed for standard applications with asynchronous (induction) motors. These applications have less stringent requirements regarding the dynamics and accuracy of the motor speed.
- SINAMICS S handles complex drive tasks with synchronous and asynchronous (induction) motors and fulfills stringent requirements regarding
 - dynamics and accuracy,
 - integration of extensive technological functions in the drive control system

Platform concept and Totally Integrated Automation

All SINAMICS versions are based on a platform concept. Common hardware and software components, as well as standardized tools for design, configuration and commissioning tasks, ensure high-level integration across all components. SINAMICS handles a wide variety of drive tasks with no system gaps. The different SINAMICS versions can easily be combined with each other.

SINAMICS is a part of the Siemens "Totally Integrated Automation" concept. Integrated SINAMICS systems covering configuration, data storage and communication at the automation level, ensure low-maintenance solutions with the SIMATIC, SIMOTION and SINUMERIK control systems.

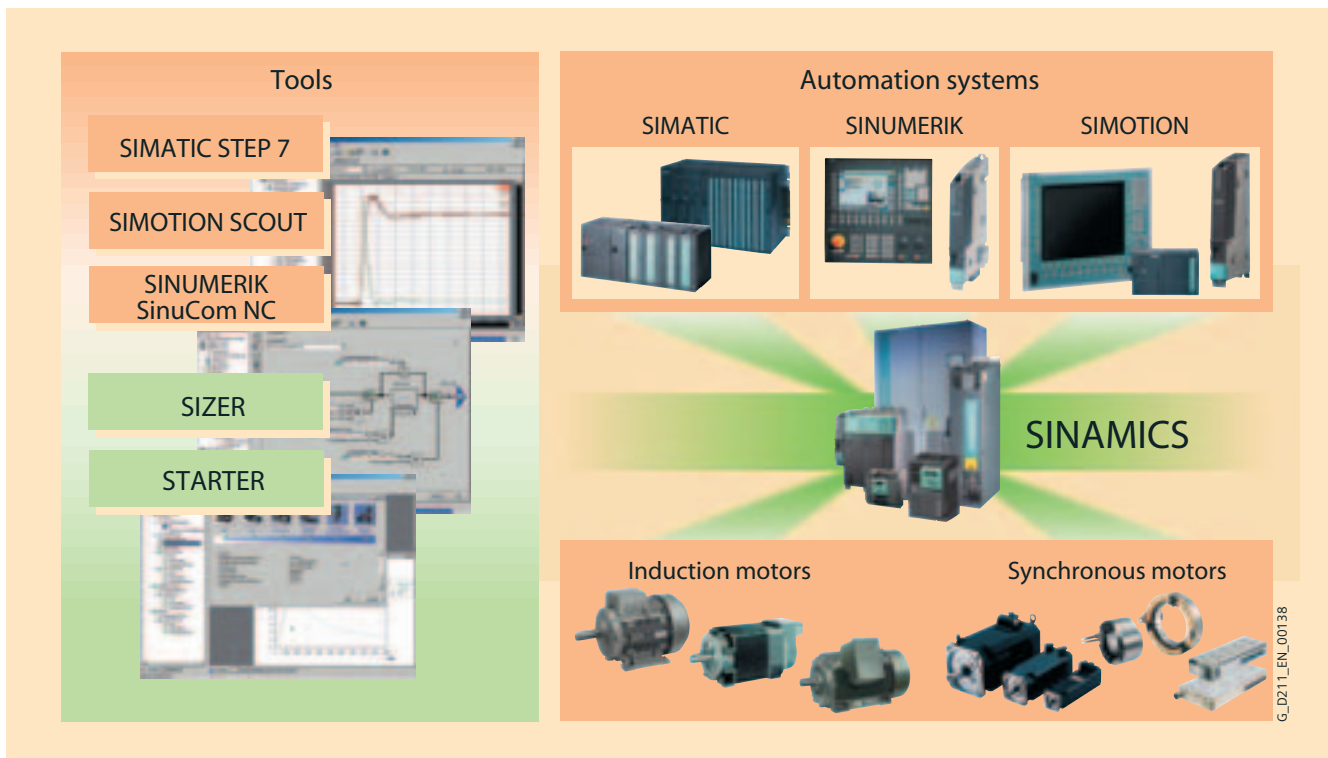

SINAMICS as part of the Siemens modular automation system

Quality in accordance with EN ISO 9001

SINAMICS conforms to the most exacting quality requirements. Comprehensive quality assurance measures in all development and production processes ensure a consistently high level of quality.

Of course, our quality assurance system is certified by an independent authority in accordance with EN ISO 9001.

Suitable for global use

SINAMICS meets the requirements of relevant international standards and regulations – from the EN standards and IEC standards to UL and cULus regulations.

The SINAMICS drive family

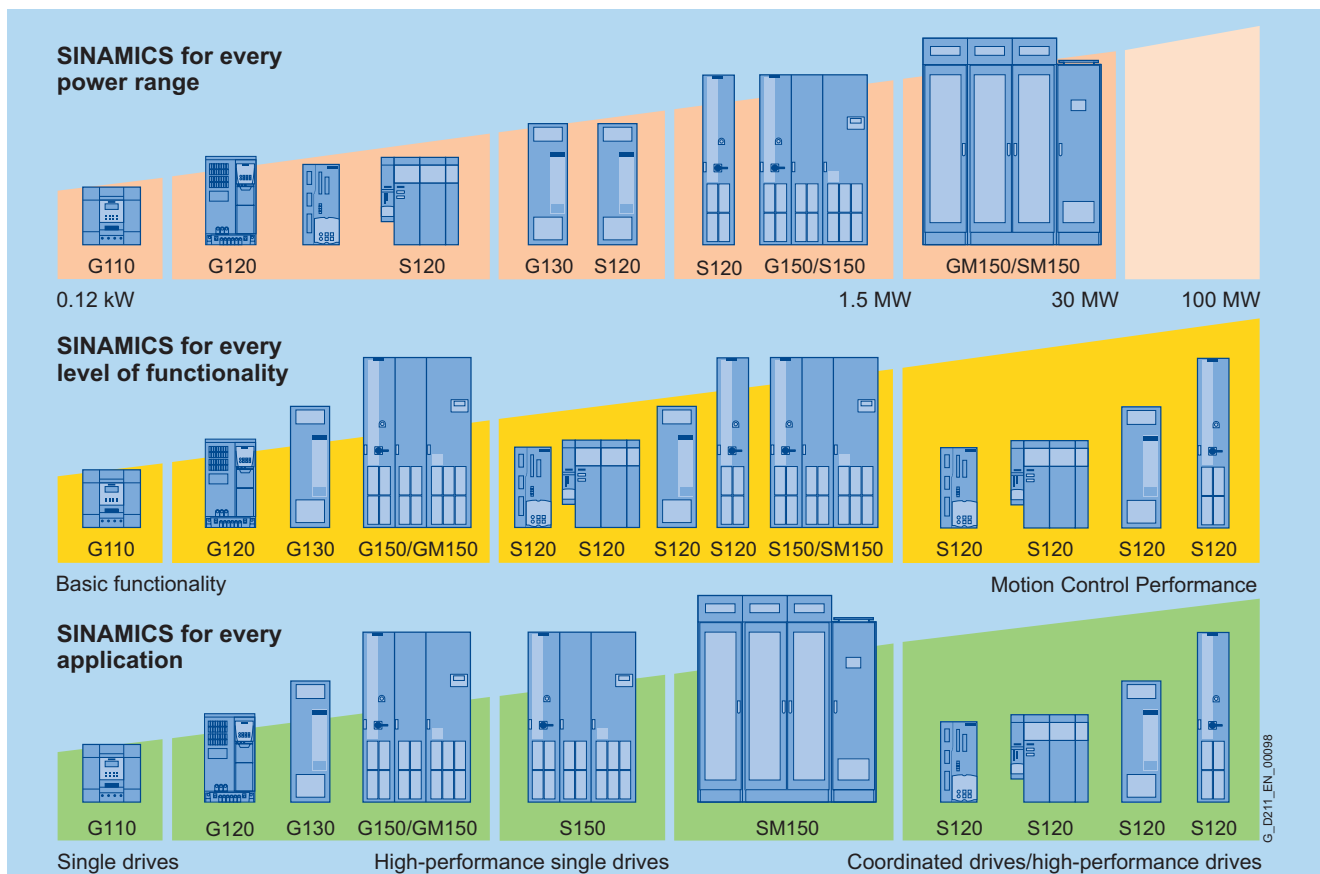

Tailored to the respective areas of application, SINAMICS is divided into the following family members:

Low-voltage drives (line supply < 1000 V)

- **SINAMICS G110** – the versatile drive for low outputs
- **SINAMICS G120** – the modular single drive for low to medium power ranges
- **SINAMICS G130** and **SINAMICS G150** – the universal drive solution for high-power single drives
- **SINAMICS S120** – the flexible, modular drive system for demanding tasks
- **SINAMICS S150** – the sophisticated drive solution for high-performance single drives

Medium-voltage drives (line supply > 1000 V)

- **SINAMICS GM150** – the universal drive solution for single drives
- **SINAMICS SM150** – the sophisticated drive solution for single and multi-motor drives

The SINAMICS range is characterized by the following system features:

- uniform functionality based on a single platform concept
- standardized engineering
- high degree of flexibility and combination
- wide power range
- designed for global use
- SINAMICS Safety Integrated
- greater efficiency and effectiveness
- multiple communications options
- Totally Integrated Automation

SINAMICS S120 drive system

**Flexibility for successful machine design**

As part of the SINAMICS drive family, the SINAMICS S120 drive is a modular system for high-performance applications in machine construction and plant engineering. SINAMICS S120 offers high-performance single-axis and multi-axis drives for a very broad range of industrial applications. By virtue of its scalability and flexibility, SINAMICS S120 is the ideal system for satisfying the ever increasing demand for more axes and better performance. SINAMICS S120 supports flexible machine designs and faster implementation of customized drive solutions.

The response to ever increasing demands

Today modern machines must be built at lower cost, but deliver greater productivity. The SINAMICS S120 drive concept meets both these challenges! It is easy to configure and thus helps to reduce project completion times. Its excellent dynamic response and accuracy permit higher cycle rates for maximum productivity.

Applications in machine and plant engineering

Regardless of whether the application involves continuous material webs or cyclic, highly dynamic processes – SINAMICS S120 means increased machine performance in many sectors:

- Packaging machines
- Plastics processing machines
- Textile machines
- Printing machines
- Paper machines
- Hoisting equipment
- Handling and assembly systems
- Machine tools
- Rolling mills
- Test stands

Modularity for machine construction

SINAMICS S120 is designed to allow free combination of power and control performance. Multi-axis drives with higher-level motion control can be implemented with the SINAMICS S120 modular system as easily as single-drive solutions.

Greater flexibility with central control intelligence

On the SINAMICS S120, the drive intelligence is combined with closed-loop control functions in Control Units.

These units are capable of controlling drives in Vector, Servo and *V/f* modes. They also perform the speed and torque control functions plus other intelligent drive functions.

Free performance selection for Vector and Servo control modes

The use of a SINAMICS S120 in Vector control mode is recommended for drive solutions with continuous material webs, for example, wire-drawing machines, film and paper machines, as well as for hoisting gear, centrifuges and marine drives.

Servo control with SINAMICS S120 is employed for cyclic processes with precise, highly dynamic position control and servo motors, e.g. in textile, packaging, printing machines and machine tools.

SINAMICS S120 – functions for better efficiency

- Basic functions: Speed control, torque control, positioning functions
- Intelligent starting functions for independent restart after power supply interruption
- BICO technology with interconnection of drive-related I/Os for easy adaptation of the drive system to its operating environment
- Integrated safety functions for realizing the implementation of safety concepts
- Regulated infeed/regenerative feedback functions for preventing undesirable reactions on the supply, allowing recovery of braking energy and ensuring greater stability against line fluctuations.

DRIVE-CLiQ – the digital interface between all components

All SINAMICS S120 components, including the motors and encoders, are interconnected by a shared serial interface called DRIVE-CLiQ. DRIVE-CLiQ forms the backplane for the complete drive system. The standardized cables and connectors reduce the variety of different parts and cut storage costs. Converter boards (Sensor Modules) for converting standard encoder signals to DRIVE-CLiQ are available for third-party motors and retrofit applications.

Swift and automatic: The electronic rating plate

An important digital linkage element of the SINAMICS S120 drive system is the electronic rating plates integrated in every component. They allow all drive components to be detected automatically via a DRIVE-CLiQ link. As a result, data does not need to be entered manually during commissioning or component replacement – helping to ensure that drives are commissioned quickly and successfully! The electronic rating plates of the motors contain, for example, the parameters of the electrical equivalent circuit diagram and the characteristic data of the built-in motor encoder, information such as order and identification numbers.

SINAMICS S120 drive system

Modular design ensures flexibility and scalability

The multi-axis design, also, referred to as common DC bus, is very modular with a power offering of Line Modules and Motor Modules – both available in booksize and chassis formats. Line Modules function as the central energy supply to the voltage-source DC link. Line Modules are optionally available with regulated infeed/regenerative feedback to provide a constant DC link voltage. Motor Modules (DC/AC units) supply the motors with energy from the DC link. All the drive intelligence is organized into Control Units. The control units perform all the closed-loop control functions for the drive grouping. They also handle all other drive functions such as the interconnection of drive related I/O's, positioning functions, etc. and feature PROFIBUS DP or PROFINET as the central interface for linking to higher level automation systems.

On single axis units, also referred to as AC drives, the rectifier and inverter power section are contained in one device, the Power Module – available in blocksize and chassis formats. For single axis applications, drive control functions are performed by a single axis Control Unit (e.g. CU310) mounted on to the Power Module. This separation of power and intelligence allows for maximum flexibility and scalability. Integration into multi-axis applications is easily accomplished by connecting a DRIVE CLiQ link to a multi-axis Control Unit (e.g. CU320). This is accomplished by mounting a CU adapter (CUA31) on a block size Power Module in place of the single axis Control Unit.

Together this integrated line offers the most optimal drive solution for any application servo or vector.



Blocksize, booksize and chassis formats

All formats can be combined freely

The different SINAMICS S120 formats can be combined freely thanks to their DRIVE-CLiQ interfaces, e.g. Line Modules in chassis format can be freely combined with Motor Modules in booksize format for multi-axis applications with high or varying total output requirements.

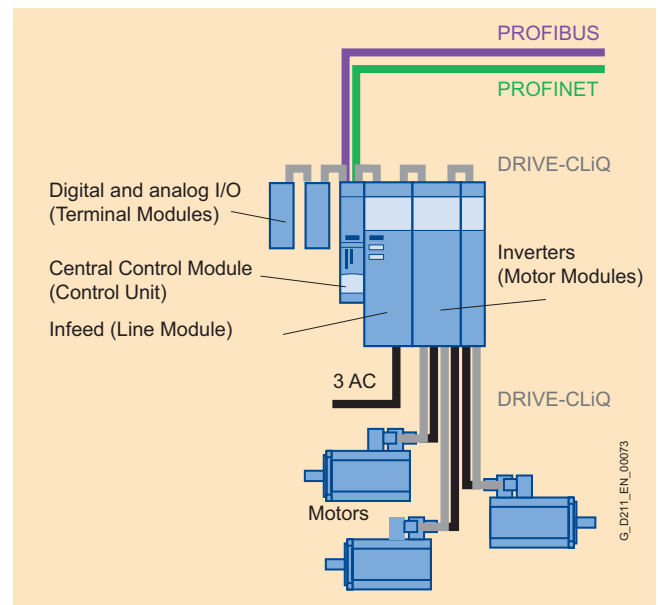
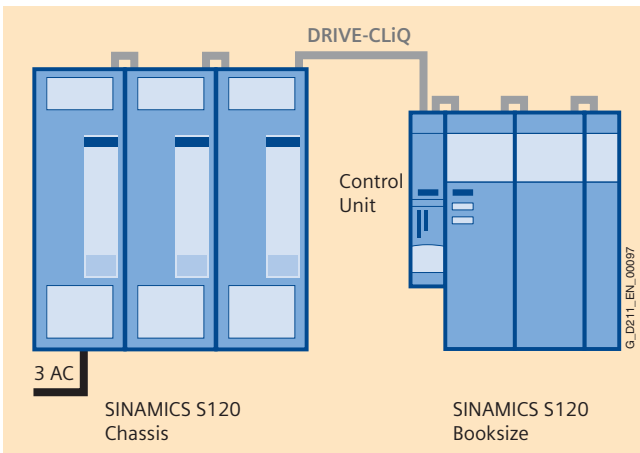

SINAMICS S120 drive system

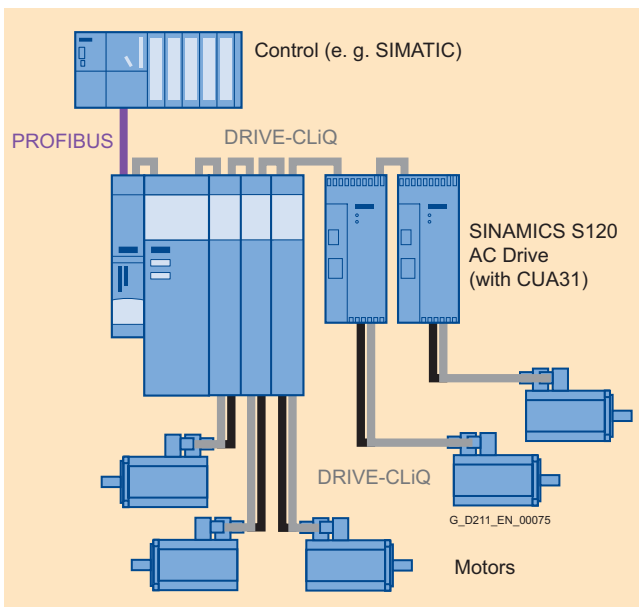
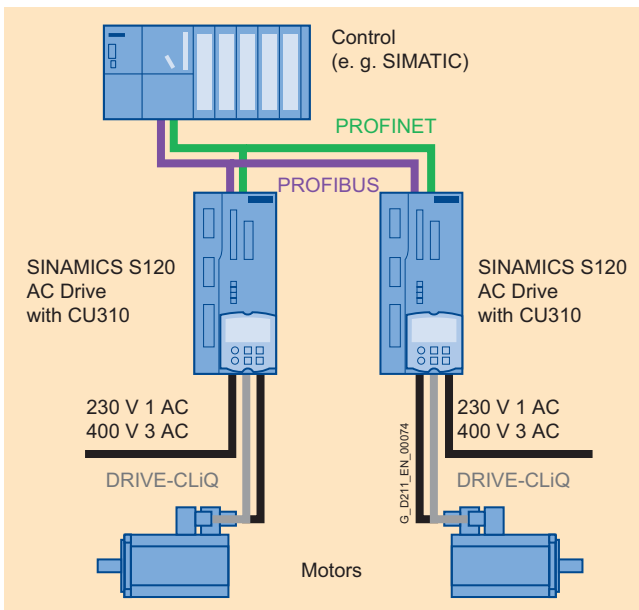
**SINAMICS S120 and SIMOTION – the perfect team**

Modern machines must be capable of handling ever more complex motion control tasks and performing the task with increasing accuracy and speed. In regards to this requirement, the SIMOTION Motion Control System and high-performance SINAMICS S120 drive system form a perfect team. The SIMOTION D variant, which is physically integrated in the SINAMICS S120 drive, is the ideal solution for machines with a large number of axes and stringent precision requirements. This distributed automation structure allows the machine to be segmented into various axis groupings, with each grouping controlled by a separate SIMOTION Motion Control System. The SIMOTION systems communicate either via PROFIBUS DP or PROFINET. Another important aspect: The compact machine design, thanks to the distributed automation structure and a Control Unit directly in the drive.

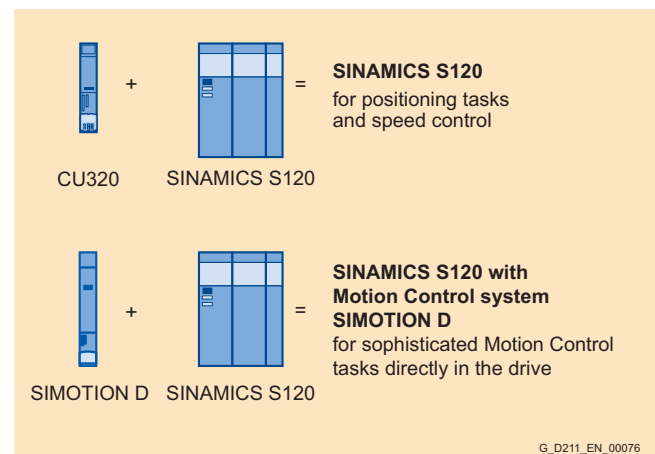
**Totally Integrated Automation – the unique automation platform**

With Totally Integrated Automation (TIA), Siemens is the only single-source provider to offer an integrated spectrum of products and systems for all sectors. Tailored to meet individual customer requirements, sector-specific automation solutions can be implemented efficiently on the basis of TIA. Lower life-cycle costs for plant operation and a significant reduction in the time to market result in a marked improvement in productivity and greater investment security.

Easy – Totally Integrated Automation with SINAMICS S120

Apart from SIMATIC, SIMOTION and SINUMERIK, SINAMICS is also one of the core components of TIA. The STARTER commissioning tool is therefore an integral element of the TIA platform. It is thus possible to parameterize, program and commission all components in the automation system using a standardized engineering platform and without any gaps. The system-wide data management functions ensure consistent data and simplify archiving of the entire plant project.

PROFIBUS – the No. 1 fieldbus

PROFIBUS DP, the standard fieldbus of the TIA system, is supported by all SINAMICS S120 variants. It provides a high-performance system-wide communication network which links all automation components: HMI, controls, drives and I/O devices.

PROFINET – for enhanced performance and open IT communication

SINAMICS S120 is also available with a PROFINET interface. This Ethernet-based bus enables control data to be exchanged at high speed via PROFINET IO with IRT or RT and makes SINAMICS S120 a suitable choice for integration in top-performance multi-axis applications.

At the same time, PROFINET also uses standard IT mechanisms (TCP/IP) to transport information, e.g. operating and diagnostic data, to higher-level systems. A SINAMICS S120 with this interface can thus easily be integrated into factory IT networks.

SINAMICS S120 drive system

The components of the SINAMICS S120 drive system

SINAMICS S120 drive system

Line-side components

Line reactors

Line filters

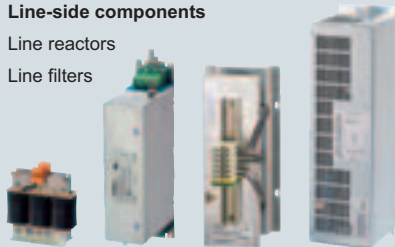

Line Modules

Basic Line Modules

Smart Line Modules

Active Line Modules

Active Interface Modules

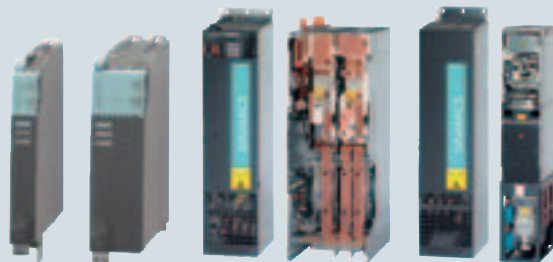

Power supply

For applicable 24 V device, see Catalog KT 10.1



DC link components

Braking Module

Braking resistors

Capacitor Module

Control Supply Module



Control Units

CU310

CU320



SIMOTION Control Units

D425

D435

D445

CX32



Motor Modules

Single Motor Modules

Double Motor Modules

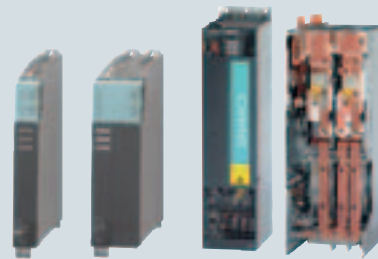

Sensor Modules

SMC10/SMC20

SMC30

SME20/SME25



Power Modules



Load-side components

Motor reactors

Sinusoidal filters



AC motors

Synchronous motors

1FT6 motors

1FK7 motors

1FS6 motors

1FW3 torque motors

Gear units

Geared motors

Asynchronous motors

1PH7 motors

1PL6 motors

1PH4 motors

Connection system

MOTION-CONNECT

Power cables

Signal cables

SINAMICS S120



2/2	System overview
2/6	General technical data
2/7	Communication
2/8	PROFIdrive
2/10	PROFIBUS
2/11	PROFINET
2/14	Control Units
2/17	CU310 DP Control Unit
2/20	CU310 PN Control Unit
2/23	CU320 Control Unit
2/26	CompactFlash Card for CU310/CU320
2/28	SIMOTION D Control Units
2/31	SIMOTION CX32 Controller Extension
2/32	Engineering software
2/32	STARTER drive/commissioning software
2/33	Drive ES engineering system
2/34	SIMOTION SCOUT engineering software
2/35	Power Modules and line-side components
2/35	Power Modules in blocksize format
2/47	Line reactors
2/50	Line filters
2/51	Recommended line-side components
2/52	Power Modules in chassis format
2/57	Line reactors
2/58	Line filters
2/59	Recommended line-side components
2/60	Line Modules and line-side components
2/60	Basic Line Modules in chassis format
2/66	Line reactors
2/67	Line filters
2/68	Recommended line-side components
2/69	Smart Line Modules in booksize format
2/76	Line reactors
2/77	Line filters
2/78	Recommended line-side components
2/79	Active Line Modules in booksize format
2/85	Line reactors
2/87	Wideband Line Filters
2/88	Basic Line Filters
2/89	Recommended line-side components
2/91	Active Line Modules in chassis format
2/98	Active Interface Modules
2/104	Recommended line-side components

2/105	Motor Modules
2/105	Single Motor Modules in booksize format
2/114	Single Motor Modules in chassis format
2/126	Double Motor Modules in booksize format
2/133	DC link components
2/133	Braking Modules in booksize format
2/135	Braking Modules in chassis format
2/138	Braking resistors for blocksize format
2/140	Braking resistors for booksize format
2/141	Braking resistors for chassis format
2/143	Capacitor Modules in booksize format
2/144	Control Supply Modules in booksize format
2/146	DC link supply adapter for booksize format
2/147	Voltage Clamping Module in booksize format
2/148	Load-side power components
2/148	Motor reactors for blocksize format
2/151	Motor reactors for booksize format
2/153	Motor reactors for chassis format
2/157	Sinusoidal filter for chassis format
2/159	Supplementary system components
2/159	BOP20 Basic Operator Panel
2/160	CBC10 Communication Board
2/161	CBE20 Communication Board
2/162	CBE30 Communication Board
2/163	CUA31 Control Unit Adapter
2/165	DMC20 DRIVE-CLiQ Hub Module
2/166	TB30 Terminal Board
2/168	TM15 Terminal Module
2/170	TM31 Terminal Module
2/172	TM41 Terminal Module
2/174	VSM10 Voltage Sensing Module
2/176	Brake Relay/Safe Brake Relay
2/178	Encoder system connection
2/179	SMC10 Sensor Module Cabinet-Mounted
2/180	SMC20 Sensor Module Cabinet-Mounted
2/181	SMC30 Sensor Module Cabinet-Mounted
2/182	SME20/SME25 Sensor Modules External



System overview

Overview

With its separate power unit and Control Unit, the SINAMICS S120 drive system can be perfectly adapted to a wide variety of different drive tasks.

The Control Unit is selected according to the number of drives to be controlled and the required performance level, while the power unit must be rated to meet the energy requirements of the system. The connection between the Control Unit and power unit is made very simply using the digital system interface DRIVE-CLiQ.

Control Units



CU310 DP, CU320 and SIMOTION D Control Units

CU310 DP and CU310 PN Control Unit

CU310 Control Units are designed to control a single drive. They feature as standard a PROFIBUS interface (CU310 DP) or PROFINET interface (CU310 PN) and a TTL/HTL encoder evaluation circuit.

CU320 Control Unit

The CU320 Control Unit has been designed to control multiple drives. A CU320 is capable of operating up to

- 8 drives in V/f control mode or
- 6 drives in Servo control mode or
- 4 drives in Vector control mode.

The CU320 Control Unit can be used to create links between individual drives and implement simple technology functions.

SIMOTION D425, D435, D445 Control Units

A SIMOTION D Control Unit is used for applications requiring coordinated motion control such as synchronous operation, electronic gear, cam disk or complex technology functions. SIMOTION D Control Units are available in a range of performance variants:

- A SIMOTION D425 Control Unit can control up to 16 axes,
- A SIMOTION D435 Control Unit can control up to 32 axes,
- A SIMOTION D445 Control Unit can control up to 64 axes.

The STARTER commissioning tool is used to commission and diagnose the various types of Control Units. The SCOUT engineering system, which includes the STARTER tool, is required for SIMOTION D Control Units.

For further information about STARTER and SCOUT, see Engineering Software.

Power Modules

The stand alone version of a SINAMICS S120 drive system consists of a CU310 Control Unit and a Power Module. A mains rectifier, a voltage-source DC link and an inverter for supplying a motor are integrated in the Power Module.



Power Module in blocksize format with CU310 DP Control Unit

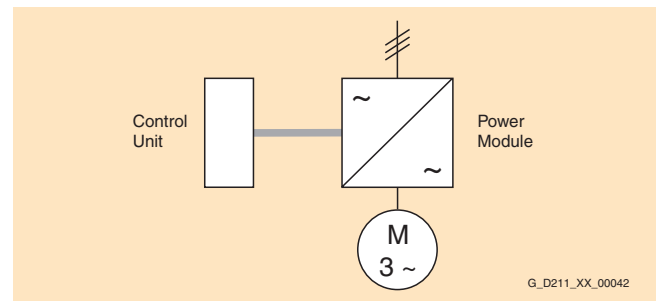

Power Modules are designed for single drives which are not capable of regenerating energy to the supply. Generated energy produced during braking is converted to heat via braking resistors.

Power Modules can also be operated by a CU320 or a SIMOTION D Control Unit, e.g. in configurations where a single drive has been added to a multi-axis drive grouping. In this case, the Power Modules in blocksize format must be equipped with the CUA31 Control Unit Adapter. This is connected with the CU320 or SIMOTION D Control Unit using DRIVE-CLiQ. Power Modules in chassis format can be directly connected to the multi-axis Control Unit using a DRIVE-CLiQ cable.

Overview (continued)

Motor Modules

A voltage-source DC link and an inverter for supplying a motor are integrated in the Motor Module.



CU320 Control Unit, Line Module and two Motor Modules in booksize format

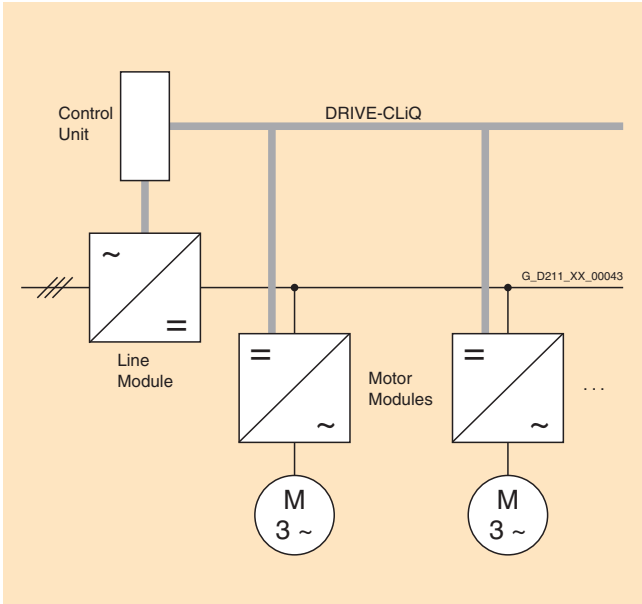

Motor Modules are designed for multi-axis drive systems and are controlled by either a CU320 or a SIMOTION D Control Unit. Motor Modules are interconnected by means of a shared DC busbar. Since the Motor Modules share the same DC link, they can exchange energy with one another, i.e. if one Motor Module operating in generator mode produces energy, the energy can be used by another Motor Module operating in motor mode. The voltage-source DC link is supplied with mains voltage by a Line Module.

Line Modules

Line Modules generate a DC voltage from the line voltage and supply Motor Modules with energy via the voltage-source DC link.

Basic Line Modules

Basic Line Modules are designed only for infeed operation, i.e. they are not capable of recovering regenerative energy to the supply system. If regenerative energy is produced, e.g. when drives brake, it must be converted to heat by means of a Braking Module and a braking resistor. When a Basic Line Module is used as the infeed, the matching line reactor must be installed. A line filter can be installed optionally to restrict conducted interference to Class C2 limits (EN 61800-3).

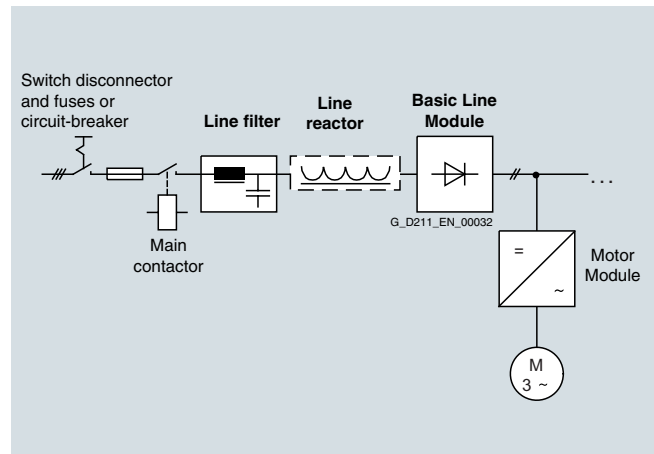

Smart Line Modules

Smart Line Modules can supply energy and return regenerative energy to the supply system. A Braking Module and braking resistor are required only if the drives need to be decelerated in a controlled manner after a power failure (i.e. when energy cannot be recovered to the supply). When a Smart Line Module is used as the infeed, the matching line reactor must be installed. A line filter can be installed optionally to restrict conducted interference to Class C2 limits (EN 61800-3).

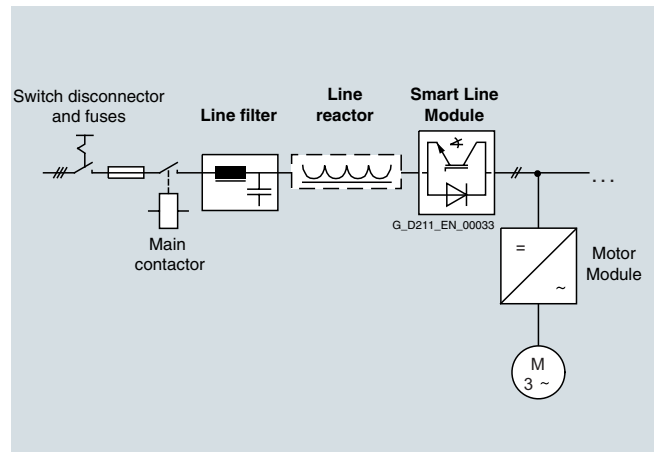

System overview

Overview (continued)

Active Line Modules

Active Line Modules can supply energy and return regenerative energy to the supply system. A Braking Module and braking resistor are required only if the drives need to be decelerated in a controlled manner after a power failure (i.e. when energy cannot be recovered to the supply). In contrast to Basic Line Modules and Smart Line Modules, however, Active Line Modules generate a regulated DC voltage which remains constant despite fluctuations in the line voltage. In this case, the line voltage must remain within the permissible tolerance range. Active Line Modules draw a virtually sinusoidal current from the supply which limits any harmful harmonics.

- Active Line Modules in booksize format

When an Active Line Module is used as the infeed, the matching line reactor must be installed. To minimize interference emission, the Active Line Module should always be operated with a combination of line filter and line reactor.

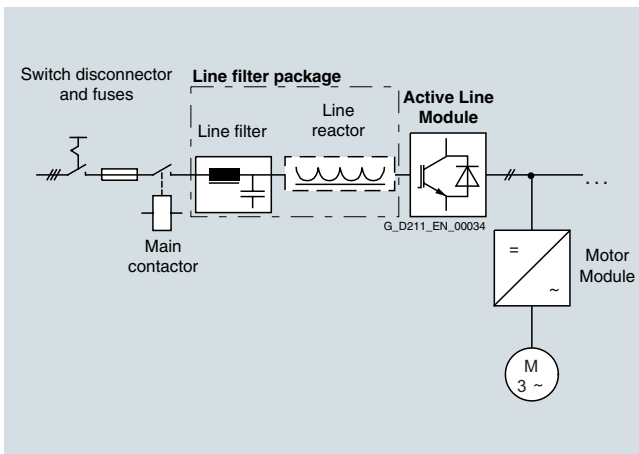

- Active Line Modules in chassis format

All the components required to operate an Active Line Module are integrated in the Active Interface Module. An external bypass contactor is required in addition for sizes HX and JX.

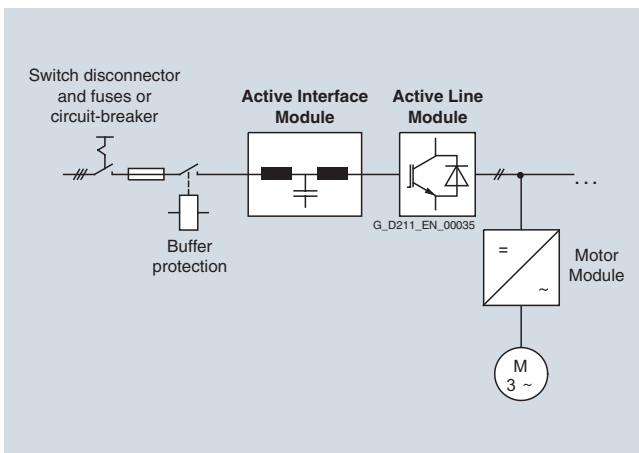

Please refer to the System Description for more information about designing a drive system with SINAMICS S120.

Power Modules, Motor Modules and Line Modules are available in formats "booksize", "blocksize" and "chassis"

- Power Modules in blocksize and chassis formats for single axis,
- Motor Modules and Line Modules for multi axis in booksize and chassis formats.

Booksize format

Booksize format units are optimized for multi-axis applications and are mounted adjacent to one another. The connection for the shared voltage-source DC link is an integral feature.



The booksize format offers a greater range of cooling options:

Internal air cooling

In this standard solution, the power loss from the electronics and power units of the drive components is removed by natural cooling or by a forced-ventilation system and routed to the interior of the control cabinet.

External air cooling

External air cooling uses the "through-hole" method. The components' power unit heat sinks pass through the mounting surface in the control cabinet and can thus release the heat losses of the power circuit to a separate external cooling circuit. The only heat loss that remains in the cabinet is emitted by the electronics. Degree of protection IP54 can be achieved at this "mechanical interface". The heat sink, with its cooling fins and the fan unit (part of the scope of supply), protrudes through the back into a separate ventilation area, which can also open outwards.

Overview (continued)

Cold-plate cooling

Units designed with cold-plate cooling can pass the power unit heat losses to an external heat sink via a thermal interface on the unit's rear panel. This external heat sink is water-cooled, for example. For further information about cold-plate cooling, please contact:

Siemens A&D
TCC Cabinet Cooling
E-mail: cc.cabinetcooling@siemens.com

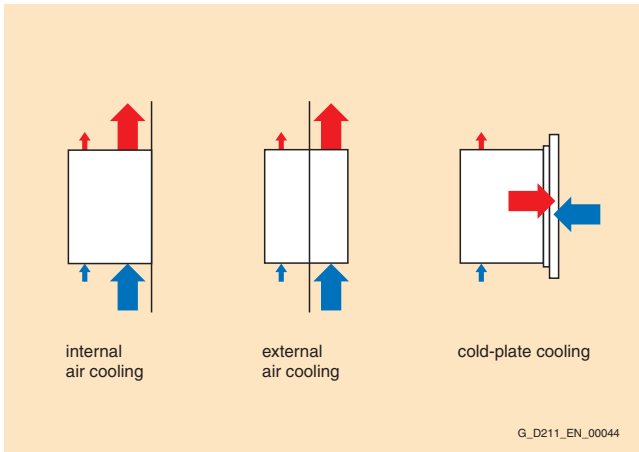

Blocksize format

Blocksize format units are optimized for single-axis applications and are available only as Power Modules.

The CU310 Control Unit can be snapped onto them directly. The units are cooled by an internal air cooling circuit.



Chassis format

Higher-output units (approximately 100 kW (150 HP) and above) are constructed in chassis format. These are available as Line Modules, Power Modules and Motor Modules. Chassis format units are cooled by an internal air cooling circuit. The CU310 Control Unit can be integrated in the Power Modules.

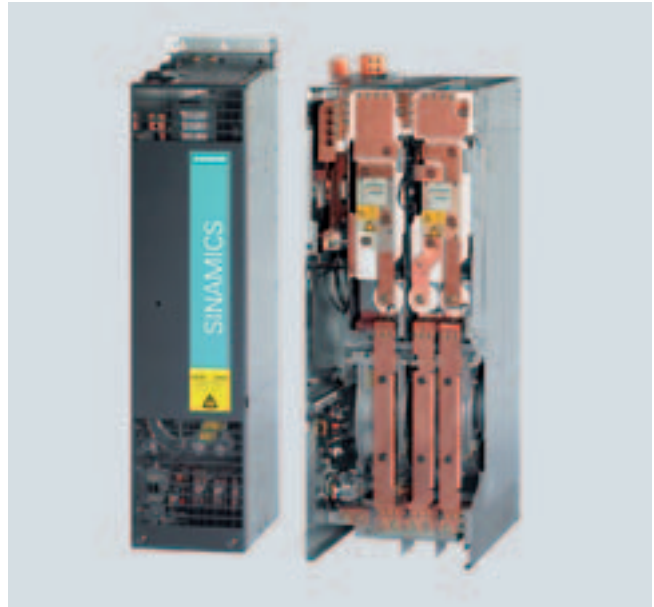

Varnished modules

The following units are equipped as standard with varnished coating:

- Blocksize format units
- Booksize format units for external air cooling
- Booksize format units with cold-plate cooling
- Control Units (SIMOTION D345 and SIMOTION D445 in preparation)
- Sensor Modules
- Terminal modules

All booksize format units for internal air cooling are available with varnished modules.

The varnish coating protects the sensitive SMD components against corrosive gases, chemically active dust and moisture.

The selection of Control Unit and Power section defines the structure of the drive system. The range of system components provided allows optimum adaptation of the drive system to the application.

System components are divided into the following categories:

- **DC link components**
e.g. Braking Modules and braking resistors,
- **Load-side power components**
e.g. motor reactors,
- **Supplementary system components**
e.g. Terminal Modules, operator panels and communication boards
- **Encoder system interface**
for connecting various types of encoder to SINAMICS S120.

SINAMICS S120

System data

General technical data

Technical data

Unless specified otherwise, the following technical specifications are valid for all the following components of the SINAMICS S120 drive system.

Electrical data	
Electronics power supply	24 V DC, 15/+ 20%
Mechanical data	
Vibratory load	
• Transport ¹⁾	Class 2M3 to EN 60721-3-2
- All units and components except for chassis format	
- Chassis format units	Class 2M2 to EN 60721-3-2
• Operation	Test values in accordance with EN 60068-2-6 test Fc:
	10 Hz to 58 Hz: Constant deflection 0.075 mm (0.003 in)
	58 Hz to 150 Hz: Constant acceleration = 9.81 m/s ² (3.2 ft/s ²) (1 × g)
Shock stressing	
• Transport ¹⁾	Class 2M3 to EN 60721-3-2
- All units and components except for chassis format	
- Chassis format units	Class 2M2 to EN 60721-3-2
• Operation	Test values in accordance with EN 60068-2-27 test Ea:
- Booksize and blocksize formats FSA to FSC	147 m/s ² (482 ft/s ²) (15 × g)/11 ms
- Blocksize format FSD to FSF	49 m/s ² (161 ft/s ²) (5 × g)/30 ms
- Chassis format	98 m/s ² (321 ft/s ²) (10 × g)/20 ms
Ambient conditions	
Protection Class	Class I (with protective conductor system) and class III (PELV) to EN 61800-5-1
Shock protection	DIN VDE 0106 Part 100 and BGV A 3 when used properly
Permissible ambient/coolant temperature (air) during operation	
• for line-side components, Power Modules, Line Modules and Motor Modules	0 °C to + 40 °C (32 °F to +104 °F) without derating, >40 °C to + 55 °C (>104 °F to +131 °F) see derating characteristics
• for Control Units, additional system components, DC link components and Sensor Modules	0 °C to + 55 °C (32 °F to +131 °F) up to 2000 m (6562 ft) above sea level
Climatic ambient conditions	
• Storage ¹⁾	Class 1K3 to EN 60721-3-1 Temperature: – 40 °C to + 70 °C (– 40 °F to + 158 °F)
• Transport ¹⁾	Class 2K4 to EN 60721-3-2 Temperature – 40 °C to + 70 °C (– 40 °F to + 158 °F) Max. air humidity 95% at 40 °C (104 °F)
• Operation	Class 3K3 to EN 60721-3-3 Condensation, splashwater and ice formation are not permitted (EN 60204, Part 1)
Environmental class/harmful chemical substances	
• Storage ¹⁾	Class 1C2 to EN 60721-3-1
• Transport ¹⁾	Class 2C2 to EN 60721-3-2
• Operation	Class 3C2 to EN 60721-3-3
Organic/biological influences	
• Storage ¹⁾	Class 1B1 to EN 60721-3-1
• Transport ¹⁾	Class 2B1 to EN 60721-3-2
• Operation	Class 3B1 to EN 60721-3-3
Degree of contamination	2 to EN 61800-5-1

¹⁾ In transport packaging

European Standards	
EN 954-1	Safety of machinery – safety-related parts of control systems; Part 1: General design principles
EN 61508-1	Functional safety of electrical/electronic/programmable electronic safety-related systems Part 1: General requirements
EN 50370-1	Electromagnetic compatibility (EMC) – Product family standard for machine tools Part 1: Emissions
EN 55011	Industrial, scientific and medical high-frequency devices (ISM devices) – radio interference – limit values and measuring techniques
EN 60204-1	Electrical equipment of machines Part 1: General definitions
EN 61800-3	Variable-speed electric drives Part 3: EMC product standard including specific test methods
EN 61800-5-1	Adjustable-speed electrical power drive systems Part 5: Safety requirements Main section 1: Electrical and thermal requirements
North American standards	
UL508C	Power Conversion Equipment
CSA C22.2 No. 14	Industrial Control Equipment

Approvals	
cULus	Testing by UL (Underwriters Laboratories) http://www.ul.com according to UL and CSA standards

Overview

Most production machines use digital communication bus systems. These handle the communication between the control level, the machine control and the executing components, i.e. the sensors and actuators. There are two types of communication: process communication and data communication.

Process communication

Process communication involves cyclically transmitting control data and setpoints. The quantity of transfer data is comparatively small. For example, a drive can communicate with between 4 and 32 bytes. The number of connected sensors and actuators is usually specified by the configuration which makes the bus cycle of process communication very constant.

Data communication

Data communication is often required for engineering and is not directly linked to the execution of the production process. Data are sporadically (acyclically) exchanged with connected devices. The volume of this communication can be very large with over 100 bytes per device and communication task.

Bus cycle

The bus cycle comprises of process communication and data communication. The cycle of the bus system is much shorter without data communication. Some say: the bus cycle breathes. However, this breathing is unsuitable for highly accurate applications in drive technology.

Requirements of drive controls

Most modern drives have a digital closed-loop control. This closed-loop control ensures that the controlled variable of the drive, for example the speed or position, are achieved and maintained. This type of digital closed-loop control comprises several intertwined controls (position, speed, current, ...). These must be matched to one another, i.e. they must be synchronized. This synchronization is important to keep the controls stable and to accurately maintain the controlled variable and/or to achieve it quickly. If some of the components of the closed-loop control are located outside the drive, a bus system must be used to manage the communication between these components. This bus system must be as synchronized as the closed-loop controls. This is referred to as isochronous operation. For drives in the area of Motion Control Systems isochronous operation must be extremely quick and very accurate. It ensures that the length of the bus cycle deviates only very slightly. This is then no longer referred to as the breathing of the bus cycle (large deviations), but as jitter (small deviations). Acceptable values are $< 1 \mu\text{s}$. This synchronization is achieved through clock signals.

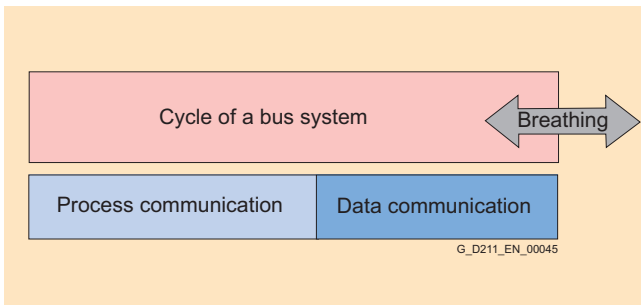

Communication types of a bus system

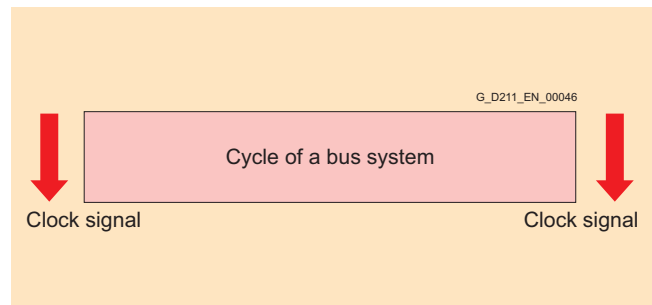

Constant bus cycle

So that a bus system can be used for Motion Control applications it must permit process communication and isochronous operation. An additional bus system is often used for data communication. PROFIBUS and PROFINET can combine all of these requirements in a single bus system. Industrial Ethernet, the predecessor of PROFINET, does not fulfill the requirements with respect to real-time communication.

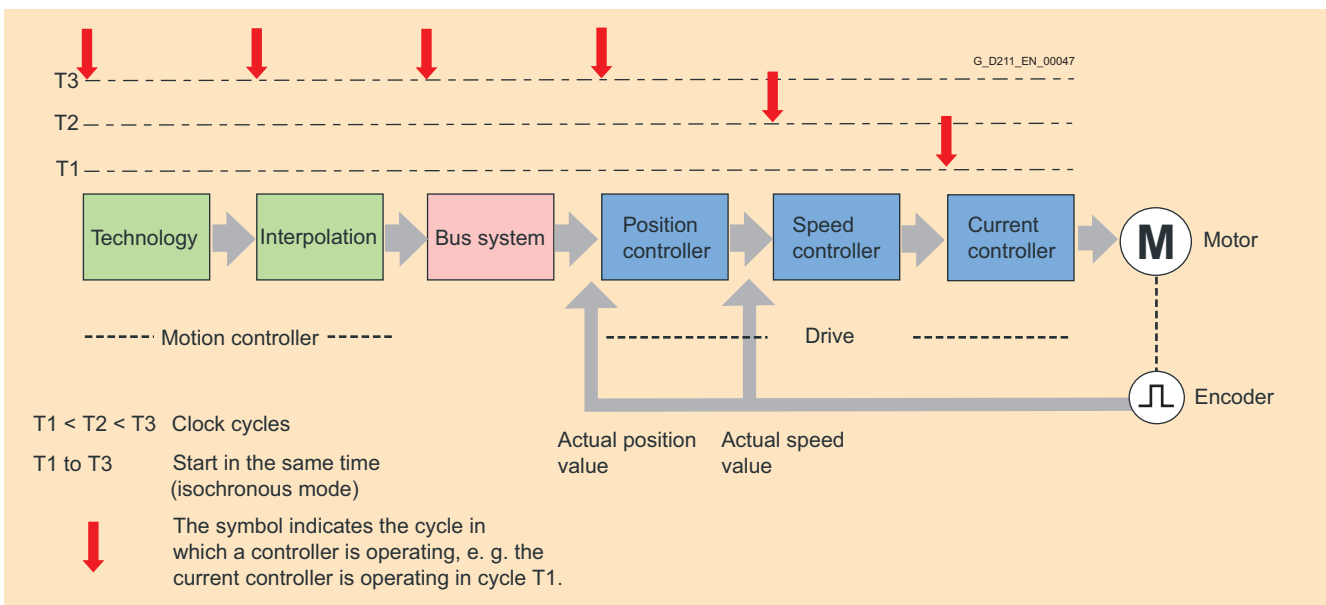

The principle of digital drive controls

Overview

What are profiles?

Profiles used in automation technology define certain characteristics and responses for devices, device groups or whole systems which specify their main and unique properties. Only devices with manufacturer-neutral, identical profiles can "interoperate" on a fieldbus and thus fully exploit the advantages of a fieldbus for the user.

Profiles are specifications defined by manufacturers and users for certain characteristics, performance features and behaviors of devices and systems. They aim to ensure that devices and systems which belong to one product family by virtue of their "product-compliant" development are interoperable and, to a certain degree, exchangeable in bus operation.

Profile types

Different types of profile can be distinguished as so-called application profiles (general or specific) and system profiles:

- Application profiles mainly refer to devices (drives) and contain an agreed selection of bus communication modes, as well as specific device applications.
- System profiles describe system classes and include the master functionality, program interfaces and integration methods.

PROFdrive

The PROFdrive profile is a specific application profile.

Design

PROFdrive in drive applications

The PROFdrive profile defines the device behavior and the access procedure to drive data for electrical drives on PROFIBUS, from simple frequency converters up to high performance servo controllers.

It contains a detailed description of how the communication functions "slave-to-slave communication", "equidistance" and "isochronous operation" are used meaningfully for drive applications. In addition, it specifies all device characteristics which influence interfaces connected to a controller over PROFIBUS or PROFINET. This includes the sequence control system, encoder interface, standardization of values, definition of standard messages, and access to drive parameters, etc.

The PROFdrive profile supports both central and distributed Motion Control concepts.

The basic philosophy: Keep it simple

The PROFdrive profile tries to keep the drive interface as simple as possible and free from technology functions. This philosophy ensures that reference models, as well as the functionality and performance of the PROFIBUS/PROFINET master, have no or very little influence on the drive interface.

Segmentation into application/utilization categories

The integration of drives into automation solutions depends heavily on the drive task. To cover the extensive range of drive applications from the most simple frequency converter up to highly dynamic, synchronized multi-axis systems with a single profile, PROFdrive defines six application categories which cover most drive applications.

- Category 1 – Standard Drives (such as pumps, fans, stirring units, etc.)
- Category 2 – Standard Drives with Technology Functions
- Category 3 – Positioning Drives
- **Category 4 – Motion Control Drives with Central, Higher-Level Motion Control Intelligence**
- Category 5 – Motion Control Drives with Central, Higher-Level Motion Control Intelligence and the Patented "Dynamic Servo Control" Position Concept
- Category 6 – Motion Control Drives with Distributed Motion Control Intelligence Integrated in the Drives

Design (continued)

PROFdrive defines a device model based on function modules which cooperate in the device and generate the intelligence of the drive system. These modules have objects assigned to them which are described in the profile and are defined with respect to their functions. The overall functionality of a drive is therefore described through the sum of its parameters.

In contrast to other drive profiles, PROFdrive defines only the access mechanisms to the parameters as well as a subset of profile parameters (about 30) such as the fault buffer, drive control and device identification.

All other parameters are vendor-specific which gives drive manufacturers great flexibility with respect to implementing control functions. The elements of a parameter are accessed acyclically over the so-called DP-V1 parameter channel.

As a communication protocol, PROFdrive uses DP-V0, DP-V1, and the DP-V2 expansions for PROFIBUS including the functions "Slave-to-Slave Communication" and "Isochronous Operation", or PROFINET IO with real-time classes RT and IRT.

PROFdrive and SINAMICS

Utilization category 4 is the most important category for highly dynamic and highly complex Motion Control tasks. This application category describes in detail the master/slave relationship between the controller and the drives which are connected to each other over PROFIBUS and PROFINET.

The DSC (Dynamic Servo Control) function significantly improves the dynamic response and stiffness of the position control circuit by minimizing the dead times which usually occur for speed setpoint interfaces with an additional, relatively simple feedback network in the drive. The position control circuit is closed in the drive which permits very fast position control cycles (e.g. 125 µs for SINAMICS S) and thus limits dead times exclusively to the control behavior.

In SINAMICS S the drive interface has been implemented according to the PROFdrive profile V4 and Utilization Categories 1 to 4 (Category 4 with and without DSC) and is referred to below as the PROFdrive interface.

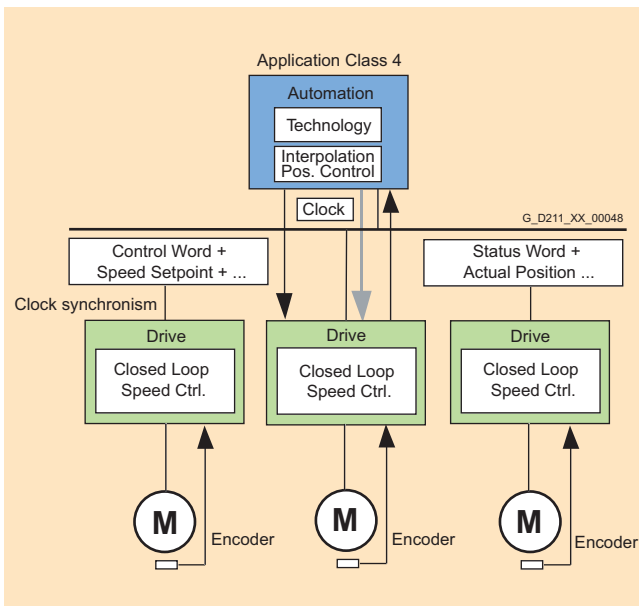

Overview

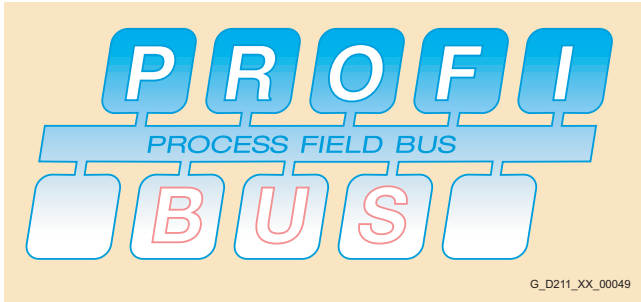

What is PROFIBUS?

PROFIBUS is the most successful open fieldbus used for automation technology which can be used for a wide range of applications. Standardization to IEC 61158 / EN 50170 provides future protection for your investment.

PROFIBUS defines the technical and functional features of a serial fieldbus system with which distributed programmable field controllers of the low-end (sensor/actuator level) to mid performance range (cell level) can be networked.

The demands of users for an open, vendor-independent communication system resulted in the specification and standardization of the PROFIBUS protocol.

Multi-vendor installations

Through the conformity and interoperability test performed by the test laboratories authorized by the PROFIBUS user organization (PNO) and the certification of the devices by the PNO, the user can rest assured that quality and functionality are also ensured for multi-vendor installations.

PROFIBUS variants

PROFIBUS FMS (Fieldbus Message Specification) – The universal solution for communication tasks on the field and cell level of the industrial communication hierarchy.

PROFIBUS PA (Process Automation) – The variant for applications in process automation. PROFIBUS PA uses the intrinsically safe transmission technology specified in IEC 61158-2.

PROFIBUS DP (Distributed Peripherals) – This variant, which is optimized for speed, is tailored especially for the communication of automation systems with distributed I/O stations and drives. The outstanding features of PROFIBUS DP are

- Very short response times
- High interference immunity

PROFIBUS replaces cost-intensive parallel signal transmission with 24 V and the measured value transmission with 0/4 mA to 20 mA technology.

PROFIBUS and SINAMICS

SINAMICS uses the PROFIBUS protocol PROFIBUS DP.

Design

Bus station

PROFIBUS DP distinguishes between two different master classes and one slave class:

Class 1 DP master

The DP master Class 1 is the central component in PROFIBUS DP. The central master station exchanges information with distributed stations (DP slaves) in a fixed, repeated message cycle.

Class 2 DP master

Devices of this type are used (programming, configuration or control devices) during start-up, for configuring the DP system, for diagnostics or controlling the plant during normal operation. A DP master Class 2 can be used, for example, to read the input, output, diagnostic and configuration data of the slaves.

DP slave

A DP slave is an I/O device which receives output information or setpoints from the DP master and sends input information, measured values or actual values to the DP master in response. A DP slave never sends data independently, it must always be prompted by the DP master.

The volume of input and output data depends on the device and can be up to 244 bytes per DP slave and transfer direction.

Function

Functions on PROFIBUS DP

The functional scope can differ between DP masters and DP slaves. The functional scope is different for DP-V0, DP-V1 and DP-V2.

DP-V0

The DP master functions (DP-V0) comprise of the functions "Configuration", "Parameter assignment", "Read diagnostic data", as well as "Cyclic reading of input data/actual values" and "Writing output data/setpoints".

DP-V1

The additional DP function expansions (DP-V1) make it possible to perform non-isochronous read and write functions, as well as processing cyclic data communication. This type of slave must be supplied with extensive parameterization data during start-up and normal operation. These acyclically transferred parameterization data are only rarely changed in comparison to the cyclic setpoints, actual values, and measured values, and are transferred at lower priority in parallel with the cyclic high-speed useful data transfer. Detailed diagnostic information can be transferred in the same way.

DP-V2

The extended DP master functions (DP-V2) mainly comprise functions for isochronous operation and direct data exchange between DP slaves.

Isochronous mode is implemented by means of a signal with a constant bus cycle for the bus system. This isochronous, constant cycle is sent by the DP master to all bus stations in the form of a global control message. The master and slaves can then synchronize their applications with this signal. The signal jitter between cycles is less than 1 μ s.

The so-called publisher/subscriber model is used to implement direct slave-to-slave communication. Slaves declared as publishers make their input data/actual values and measured values available to other slaves, the subscribers, for reading. This is performed by sending the response message to the master as a broadcast. Slave-to-slave communication is therefore a cyclic process.

SINAMICS systems and PROFIBUS DP

SINAMICS S drives can operate only as DP slaves and support all communication functions, i.e. DP-V0, DP-V1 and DP-V2.

Overview



PROFINET is the innovative and open Industrial Ethernet standard (IEC 61158) for industrial automation. With PROFINET, devices can be linked up from the field level through to the management level.

PROFINET enables system-wide communication, supports plant-wide engineering and applies IT standards right down to the field level. IT communication, data communication and cyclic process communication are combined on the basis of Industrial Ethernet.

Existing fieldbus systems such as PROFIBUS can be easily integrated without any modification of existing devices.

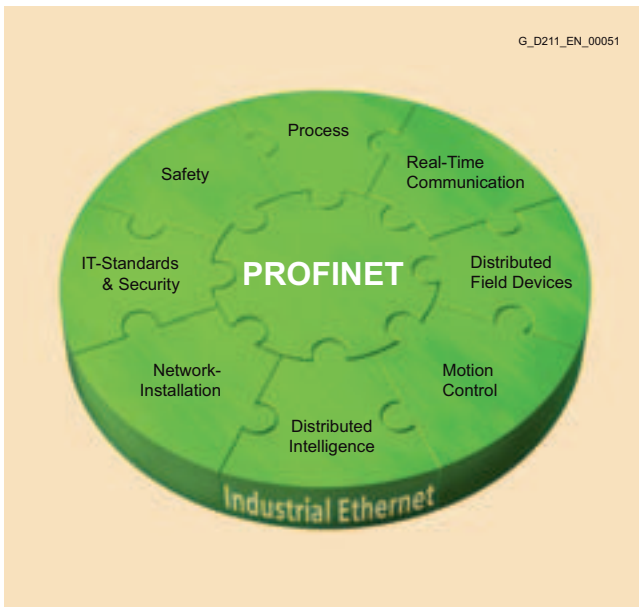

Design

PROFINET device concept

PROFINET distinguishes between the controller and devices assigned to it. These are initialized and parameterized by the controllers on power-up. The controller and its devices together constitute a PROFINET I/O system (compare master/slave system for PROFIBUS).

For PROFINET, cyclic communication between an I/O controller and its I/O devices is performed in the same way as for PROFIBUS over the process image. The process image is updated cyclically, depending on the requirements and device characteristic this takes place in real-time (RT, devices are typically distributed I/O devices) or isochronous real-time (IRT, devices are typically servo drives). In addition, PROFINET permits communication between controllers and devices of different I/O systems.

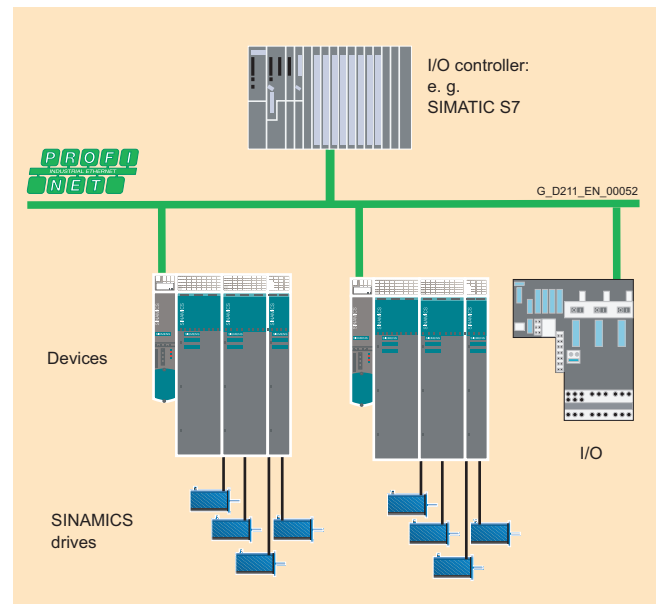

PROFINET IO with RT for simple standard drive applications

With typical cycle times of between 4 ms and 10 ms, PROFINET IO with RT offers the same performance characteristics as PROFIBUS as regards cyclic data transmission.

With this performance level, all standard drive applications belonging to PROFIdrive application categories 1 to 3 can be automated, i.e. those categories requiring the specification of speed, torque and current setpoints or target positions which do not need to be linked isochronously.

SINAMICS S120

Communication

PROFINET

Design (continued)

PROFINET IO with IRT for Motion Control

In this case, a Motion Control system (e.g. SIMOTION) controls or synchronizes axes using the PROFINET network. This requires cyclic, isochronous data exchange with the drives. PROFINET IO with IRT fulfils this requirement. The communication cycle is subdivided into different, time-specific channels for this purpose. The first channel is used for isochronous real-time communication (IRT), followed by real-time communication (RT) and standard TCP/IP communication. By configuring the application, e.g. synchronous operation of two axes, the IRT messages are determined implicitly and the corresponding configuration data are generated.

The optimum time sequence of the individual messages for each network section is calculated with a special algorithm which takes the topology into account. This permits a switch to forward the IRT messages without delay from the input port to the specified output port and then to the target device.

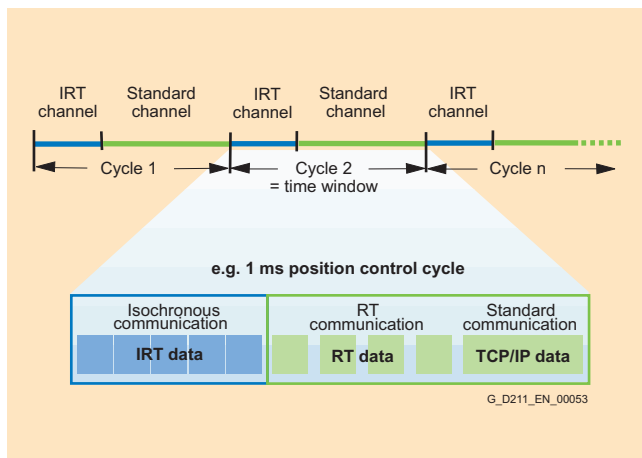

Transition from PROFIBUS to PROFINET

The functional interface between the controller and the SINAMICS drives for PROFINET and PROFIBUS is defined by the PROFdrive drive profile V4 of PROFIBUS International. It is not necessary to change an application program for the transfer between PROFIBUS and PROFINET.

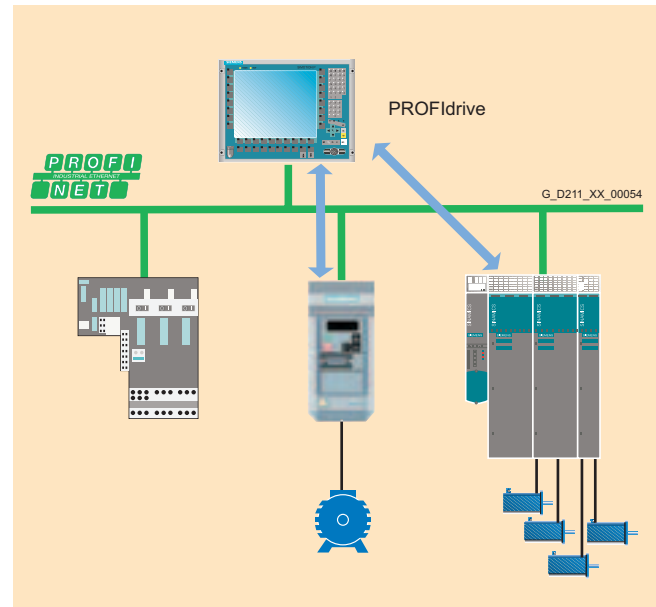

PROFINET with PROFdrive

Motion Control concepts with PROFINET

With SINAMICS, PROFINET supports the implementation of different automation structures. Distributed drive-based Motion Control concepts (e.g. with SIMOTION D) or central architectures with a control (e.g. SIMOTION P) are supported in the same way as distributed automation solutions with modular automation components.

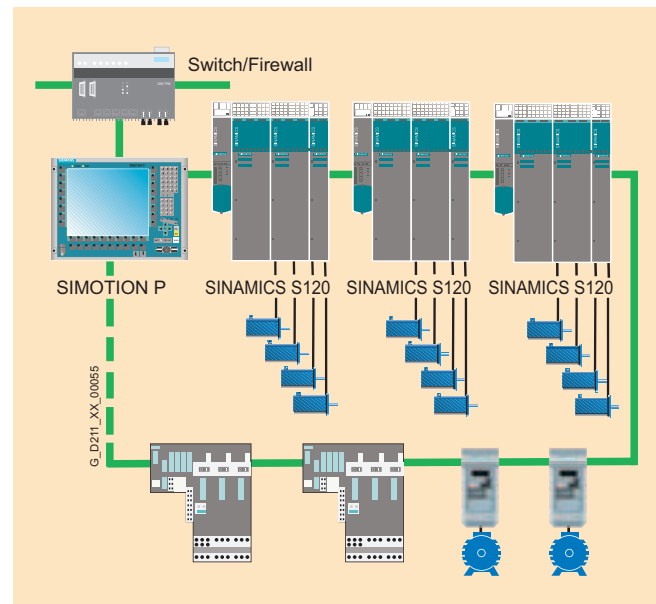

Central Motion Control architecture

Design (continued)

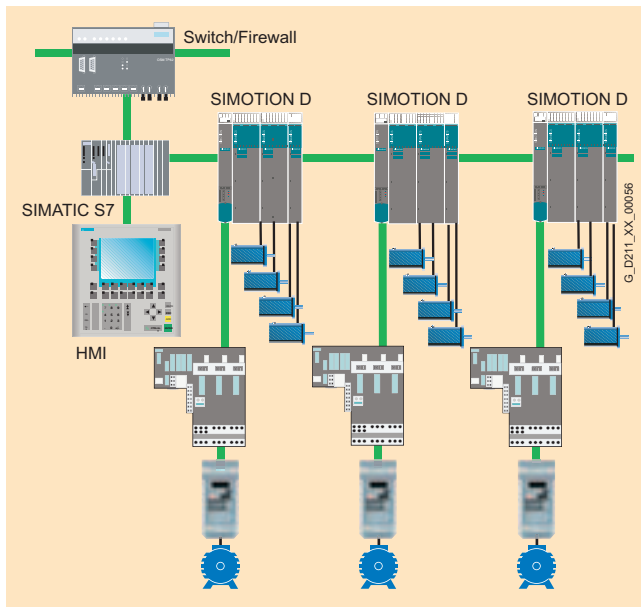

Distributed Motion Control architecture

PROFINET interface on SINAMICS

- SINAMICS S with a CU320 Control Unit and a CBE20 Communication Board
The CU320 Control Unit on SINAMICS S is linked to the PROFINET IO network via the CBE20 Communication Board. The CBE20 Communication Board includes the PROFINET ASIC ERTEC400.
 - 4 ports with one RJ45 socket each
 - Integrated 4-port switch
 - 100 Mbit/s full duplex
 - PROFINET IO device
 - PROFINET IO with RT and IRT
 - TCP/IP communication to engineering
- SIMOTION D
The SIMOTION D4x5 are linked to the PROFINET IO network via the CBE30 Communication Board. The CBE30 Communication Board includes the PROFINET ASIC ERTEC400.
 - 4 ports with one RJ45 socket each
 - Integrated 4-port switch
 - 100 Mbit/s full duplex
 - PROFINET IO controller
 - PROFINET IO with RT and IRT
 - Standard TCP/IP, UDP communication
 - PG/OP communication for connection of HMI and PG, IT communication

Function

Real-time communication with PROFINET IO

PROFINET uses standard TCP/IP for parameter assignment, configuration and diagnostics. Real-time communication for the transmission of process data is performed on the same line. PROFINET has the following real-time features:

- Real-time (RT)
uses the option of prioritizing the communication stack of the stations. This permits high-performance data transmission with standard network components.
- Isochronous Real-Time (IRT)
permits strict deterministic, cyclic data transmission with short response times and minimum jitter for high performance motion control applications. This feature is implemented with a special ASIC, the so-called ERTEC (Enhanced Real Time Ethernet Controller), in the corresponding interfaces (switch integrated into device) or network components (switch).

Automation with PROFINET

With these and other features PROFINET fulfills all automation requirements: Industry-compatible installation technology, real-time capability, deterministic responses, integration of distributed field devices, simple network administration and diagnostics, protection against unauthorized access, efficient vendor-independent engineering as well as isochronous motion control applications.

PROFINET relies on switch technology and has expanded this technology for real-time applications (IRT). This has the advantage that the network topology can be optimally utilized and adapted to the requirements of the machine. Collisions are prevented and an optimal data throughput is achieved.

SINAMICS S120

Control Units

Control Units

Overview

New system architecture with a central Control Unit

Electronically coordinated individual drives work together to perform your drive tasks. Higher-level controllers operate the drives to achieve the required coordinated movement. This requires cyclic data exchange between the controller and the drives. This exchange usually took place via a field bus, which required a great deal of time and effort for installation and configuration. SINAMICS S120 takes a different approach: A central Control Unit controls the drives for all connected axes and also establishes the technological links between the drives and/or axes. Since all the required data is stored in the central Control Unit, it does not need to be transferred. Inter-axis connections can be established within a Control Unit and easily configured in the STARTER commissioning tool using a mouse.

- Simple technological tasks can be carried out automatically by the SINAMICS S120 Control Unit
- The **CU310 DP** or **CU310 PN** Control Unit are available for single drives
- The **CU320** Control Unit is designed for multi-axis applications
- Sophisticated motion control tasks can be implemented with the support of the more powerful Control Units **D425**, **D435** and **D445** of **SIMOTION D** (graded according to performance)

Each of these Control Units is based on an object-oriented SINAMICS S120 standard firmware which contains all the most popular control modes and can be scaled to meet even the most advanced performance requirements.

The drive controls are supplied as ready-to-configure drive objects:

- for the "Infeed Control",
- for the broad scope of rugged asynchronous (induction) motor applications "Vector Control" and V/f control
- for permanent-field synchronous motors with demanding dynamic requirements "Servo Control".

The most commonly used V/f control modes are stored in the "Vector Control" drive object and are ideal for implementing even simple applications such as, for example, group drives with SIEMOSYN motors.

Drive objects

A drive object is a self-contained software function with its own parameters and, if necessary, its own fault messages and alarms.

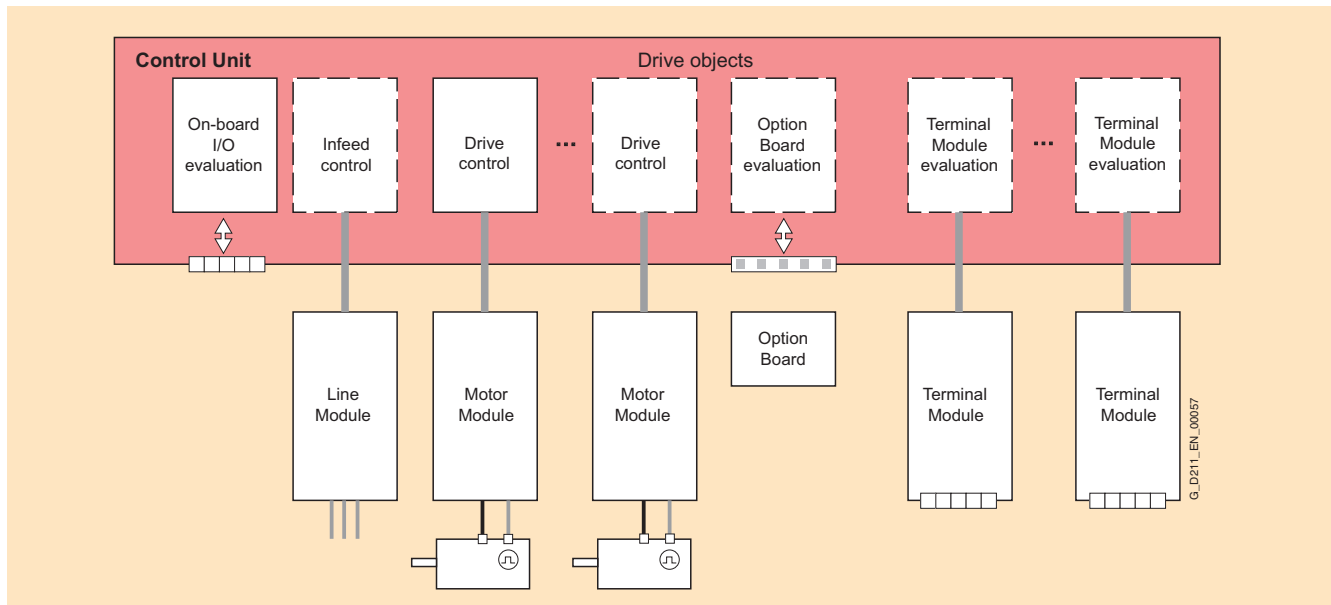

Overview (continued)

Comprehensive package of open-loop and closed-loop control functions

A wide variety of standard functions such as setpoint input, data set changeover, controller optimization, kinetic buffering, etc. ensure a high degree of operational reliability and excellent flexibility of application.

Overview of key open-loop and closed-loop control functions:

	Closed-loop control types S120	Open-loop control types S120	Main functions S120 for booksize/chassis	Comment, note
Infeed Control	<ul style="list-style-type: none"> • Booksize <ul style="list-style-type: none"> - Current control with/without mains sensor - V_{DC} control with/without mains sensor • Chassis <ul style="list-style-type: none"> - Current control with mains sensor - V_{DC} control with mains sensor 	<ul style="list-style-type: none"> • Booksize <ul style="list-style-type: none"> - Smart Line Modules can be selected • Chassis <ul style="list-style-type: none"> - Basic Line Modules can be selected 	<ul style="list-style-type: none"> • Mains identification • Controller optimization • Harmonics filter • Automatic restart 	The mains sensor is the VSM 10 Voltage Sensing Module; "current" is the line current; 3-phase with line frequency
Vector Control	<ul style="list-style-type: none"> • Asynchronous motor <ul style="list-style-type: none"> - Torque control with/without encoder - Speed control with/without encoder • Torque motor <ul style="list-style-type: none"> - Torque control with encoder - Speed control with/without encoder • For asynchronous and torque motors <ul style="list-style-type: none"> - Position control with encoder 	<ul style="list-style-type: none"> - Linear/parabolic characteristic - Fixed-frequency characteristic (textiles) - Independent voltage setpoint input 	<ul style="list-style-type: none"> • Data set changeover • Extended setpoint input • Motor identification • Current/speed controller optimization • Technology controller • Basic positioner • Automatic restart • Flying restart with/without encoder • Kinetic buffering • Synchronization • Droop 	<p>Mixed operation with V/f control modes is possible; it is for this reason that the V/f control modes are stored only once in the "Vector Control" drive object</p> <p>Position control can be selected as a function module from both Servo and Vector mode.</p> <p>Synchronous motors (1FK and 1FT) and linear motors can be operated only in Servo mode.</p>
Servo control	<ul style="list-style-type: none"> • Asynchronous motor <ul style="list-style-type: none"> - Torque control with encoder - Speed control with/without encoder • Synchronous motor, linear motor and torque motor <ul style="list-style-type: none"> - Torque control with encoder - Speed control with encoder • For all motor types <ul style="list-style-type: none"> - Position control with encoder 	<ul style="list-style-type: none"> - Linear/parabolic characteristic - Fixed-frequency characteristic (textiles) - Independent voltage setpoint input 	<ul style="list-style-type: none"> • Data set changeover • Setpoint input • Motor identification • Damping application • Technology controller • Basic positioner 	<p>Mixed operation with V/f control modes is possible; it is for this reason that the V/f control modes are stored only once in the "Vector Control" drive object</p> <p>Position control can be selected as a function module from both Servo and Vector mode.</p>

Technology packages

SIMOTION D Control Units support the coordinated motion control of multiple drives. In addition to drive objects, these Control Units also offer technology objects such as, for example, "cam controller", "synchronism", "cam disk" and "temperature control", and these objects are grouped to form technology packages. Users can create their own objects and set up links between all configured objects.

SINAMICS S120

Control Units

Control Units

Overview (continued)

BICO technology

Every drive object contains a large number of input and output variables which can be freely and independently interconnected using Binector Connector Technology (BICO). A binector is a logic signal which can assume the value 0 or 1. A connector is a numerical value, e.g. the actual speed or current setpoint.

Function modules

The "basic positioner" is used for the absolute/relative positioning of linear and rotary axes (modulo) with motor encoders (indirect measuring system) or machine encoders (direct measuring system). The "technology controller" is designed as a PID controller. It is suitable for implementing controls for regulating variables such as fill level, temperature, tension, pressure, flow rate and dancer position.

Integrated safety functions

The Control Units support safety functions such as "Safe standstill" (STO = Safe Torque Off)

CompactFlash card

The functions of the SINAMICS S120 drives are stored on a CompactFlash card. This card contains the firmware and parameter settings for all drives in the form of a project. The CompactFlash card can also hold additional projects, which means that the correct project can be accessed immediately when series machines of different types are commissioned. When the Control Unit has booted, the data on the CompactFlash card are read and loaded to the RAM.

The firmware is organized in objects. Drive objects are used to implement open-loop and closed-loop control functions for Line Modules, Motor Modules, Power Modules and other system components connected by DRIVE-CLiQ.

Diagnostics optimally supported by trace function

The time characteristics of input and output variables associated with drive objects can be measured by the integrated trace function and displayed using the STARTER commissioning tool. The trace can record up to 4 signals simultaneously. A recording can be triggered as a function of freely selectable boundary conditions, e.g. the value of an input or output variable.

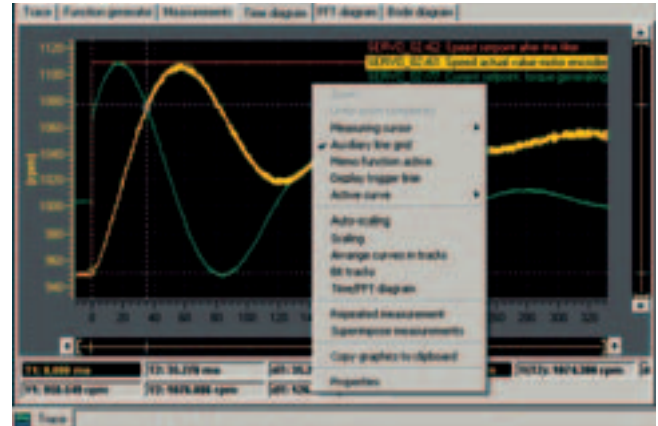

Overview



The CU310 DP Control Unit provides the communications and openloop/closed-loop control functions for a Power Module. The CU310 DP combined with a Power Module and CompactFlash card creates a powerful single axis AC drive with a PROFIBUS interface to a higher-level control.

Design

CU310 DP Control Units feature the following interfaces as standard:

- 1 DRIVE-CLiQ socket for communication with other DRIVE-CLiQ devices, e.g. Sensor or Terminal Modules
- 1 PM-IF interface for communication with Power Modules in blocksize format
- 1 interface to the BOP20 Basic Operator Panel
- 1 PROFIBUS interface with PROFIdrive V4 profile
- 1 HTL/TTL encoder evaluation circuit
- 4 parameterizable digital inputs (floating)
- 4 parameterizable bidirectional digital inputs/digital outputs (non-floating)
- 1 serial RS232 interface
- 1 slot for the CompactFlash Card on which firmware and parameters are stored
- 3 test sockets and one reference ground for commissioning support
- 1 connection for the electronics power supply via the 24 V DC power supply connector
- 1 PE (protective earth) connection

The status of the CU310 DP Control Unit is indicated via multi-color LEDs.

A BOP20 Basic Operator Panel can also be snapped directly onto the CU310 DP Control Unit for diagnostic purposes.

As the firmware and parameter settings are stored on a plug-in CompactFlash card, the Control Unit can be changed without the need for software tools.

Selection and ordering data

Description	Order No.
CU310 DP Control Unit (without CompactFlash card)	6SL3040-0LA00-0AA0

Accessories

Description	Order No.
PROFIBUS connector without PG/PC connection	6ES7972-0BA41-0XA0
PROFIBUS connector with PG/PC connection	6ES7972-0BB41-0XA0
STARTER commissioning tool	6SL3072-0AA00-0AG0

Integration

The CU310 DP Control Unit drives Power Modules in blocksize format via the PM-IF interface. In this case, other DRIVE-CLiQ components such as Sensor or Terminal Modules, can be connected to the DRIVE-CLiQ socket on the CU310 DP Control Unit.

Power Modules in chassis format are driven by the CU310 DP Control Unit via the DRIVE-CLiQ interface. With this option, Sensor and Terminal Modules must be connected to the free DRIVE-CLiQ sockets on the Power Module.

Parameter settings can be changed with the BOP20 Basic Operator Panel. The BOP20 panel can also be snapped onto the CU310 DP Control Unit during operation to perform troubleshooting procedures.

The CU310 DP Control Unit and other connected components are commissioned and diagnosed with the STARTER commissioning tool.

A CU310 DP Control Unit communicates with the higher-level control system using PROFIBUS and the PROFIdrive V4 profile.

The integrated safety functions such as e.g. "Safe Torque Off" (= "Safe standstill") must be selected in two channels. Two digital inputs on the CU310 DP Control Unit are required for this purpose.

An external 24 V supply can be connected to the CU310 to power the control unit when the incoming supply to the Power Module is not energized.

SINAMICS S120

Control Units

CU310 DP Control Unit

Integration (continued)

2

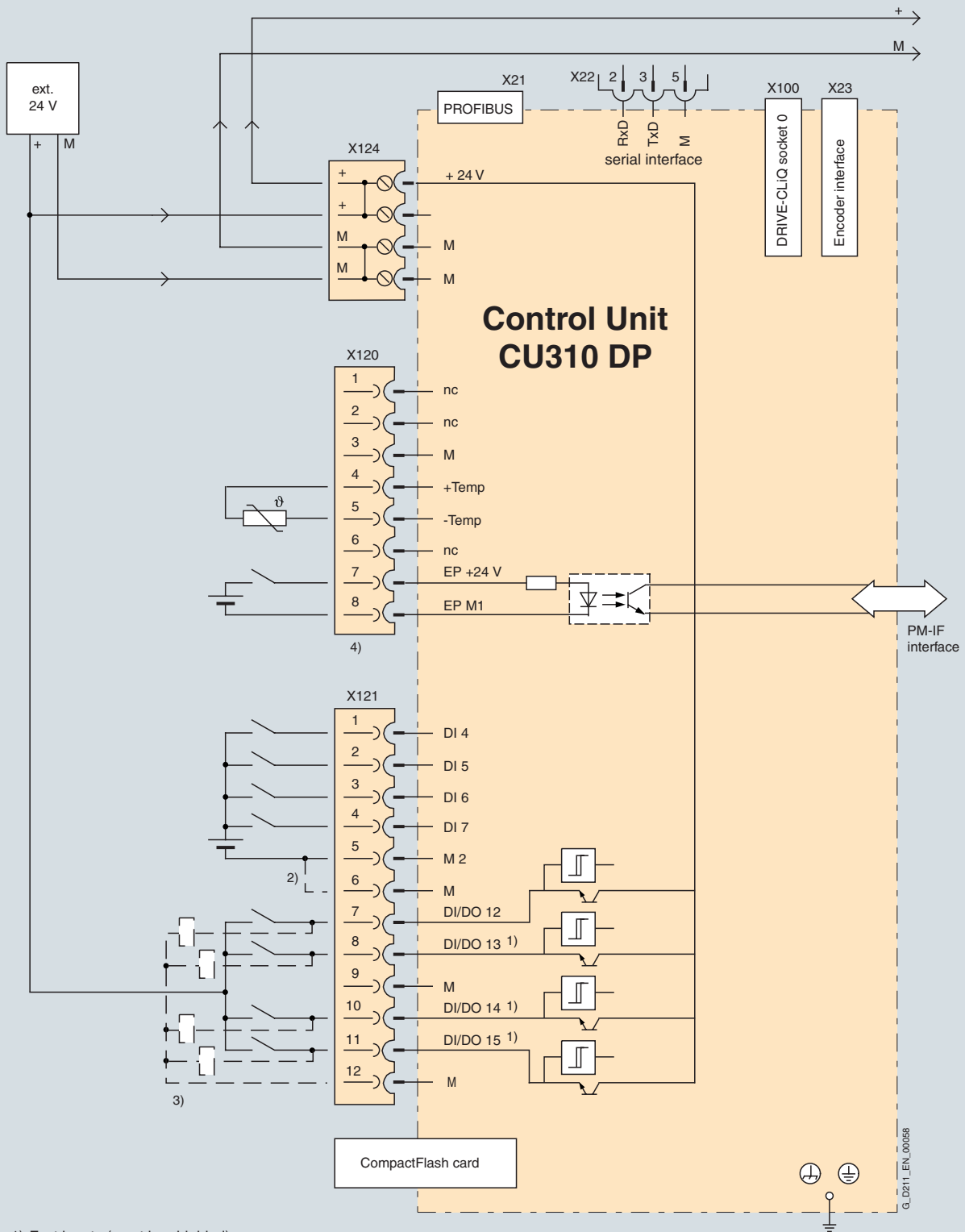

- 1) Fast inputs (must be shielded)
- 2) Jumper open, isolation for digital inputs (DI)
- 3) Can be parameterized individually as input/output
- 4) Required for Safety

Connection example of CU310 DP Control Unit

Technical data

CU310 DP Control Unit

Max. current requirement (at 24 V DC) without taking account of digital outputs and DRIVE-CLiQ supply	0.85 A
Max. connectable cross section	2.5 mm ²
Max. fuse protection	20 A
Digital inputs	4 x floating digital inputs 4 bidirectional non-floating digital inputs/digital outputs
• Voltage	– 3 V to 30 V
• Low level (an open digital input is interpreted as "low")	– 3 V to + 5 V
• High level	15 V to + 30 V
• Current consumption (typ. at 24 V DC)	10 mA
• Signal propagation delays for digital inputs ¹⁾	L → H: approx. 50 μs H → L: approx. 100 μs
• Signal propagation delays for high-speed digital inputs ¹⁾ (high-speed digital inputs can be used for position detection)	L → H: approx. 5 μs H → L: approx. 50 μs
• Max. connectable cross section	0.5 mm ²
Digital outputs (continued-short-circuit-proof)	4 bidirectional non-floating digital inputs/digital outputs
• Voltage	24 V DC
• Max. load current per digital output ²⁾	500 mA
• Delay time of the digital outputs	approx. ≈ 150 μs
• Max. connectable cross section	0.5 mm ²
Encoder evaluation	TTL or HTL incremental encoders (with adjustable parameters)
• Cut-off frequency	500 kHz
• Max. cable length for TTL incremental encoder	100 m (328 ft) (only bipolar signals permitted)
• Max. cable length for HTL incremental encoder	100 m (328 ft) for unipolar signals 300 m (984 ft) for bipolar signals
Power loss	< 20 W
PE connection	On housing with M5 screw
Width	73 mm (2.9 in)
Height	183.2 mm (7.2 in)
Depth	89.6 mm (3.5 in)
Weight, approx.	0.95 kg (2 lb)
Approvals	cULus (File No.: E164110)

¹⁾ The specified signal propagation delays refer to the hardware. The actual reaction time depends on the time slot in which the digital input or output is processed.

²⁾ In order to use the digital outputs, an external 24 V power supply must be connected to terminal X124.

SINAMICS S120

Control Units

CU310 PN Control Unit

Overview



The CU310 PN Control Unit is designed for the communication and open-loop/closed-loop control functions of a Power Module. The CU310 PN combined with a Power Module and CompactFlash card creates a powerful single axis AC drive. The communication link to the higher-level control is provided by PROFINET IO.

Design

CU310 PN Control Unit features the following interfaces as standard:

- 1 DRIVE-CLiQ socket for communication with other DRIVE-CLiQ devices, e.g. Sensor or Terminal Modules
- 1 PM-IF interface for communication with Power Modules in blocksize format
- 1 interface to the BOP20 Basic Operator Panel
- 2 x PROFINET interfaces (RJ45 sockets) with PROFIdrive V4 profile
- 1 HTL/TTL encoder evaluation circuit
- 4 parameterizable digital inputs (floating)
- 4 parameterizable bidirectional digital inputs/digital outputs (non-floating)
- 1 serial RS232 interface
- 1 slot for the CompactFlash card on which firmware and parameters are stored
- 3 test sockets and one reference ground for commissioning support
- 1 connection for the electronics power supply via the 24 V DC power supply connector
- 1 PE (protective earth) connection

The status of the CU310 PN Control Unit is indicated via multi-color LEDs.

A BOP20 Basic Operator Panel can also be snapped directly onto the CU310 PN Control Unit for diagnostic purposes.

As the firmware and parameter settings are stored on a plug-in CompactFlash card, the Control Unit can be changed without the need for tools.

Selection and ordering data

Description	Order No.
CU310 PN Control Unit (without CompactFlash card)	6SL3040-0LA01-0AA0

Accessories

Description	Order No.
STARTER commissioning tool	6SL3072-0AA00-0AG0
Industrial Ethernet FC RJ45 plug 180 (1x)	6GK1901-1BB10-2AA0
Industrial Ethernet FC RJ45 plug 180 (10x)	6GK1901-1BB10-2AB0
Industrial Ethernet FC stripping tool	6GK1901-1GA00
Industrial Ethernet FC standard cable GP 2x2	6XV1840-2AH10
Industrial Ethernet FC flexible cable GP 2x2	6XV1870-2B
Industrial Ethernet FC trailing cable GP 2x2	6XV1870-2D
Industrial Ethernet FC trailing cable 2x2	6XV1840-3AH10
Industrial Ethernet FC marine cable 2x2	6XV1840-4AH10

Further details about plugs and cables are available in the IK PI catalog.

Integration

The CU310 PN Control Unit drives Power Modules in blocksize format via the PM-IF interface. In this case, other DRIVE-CLiQ components such as Sensor or Terminal Modules can be connected to the DRIVE-CLiQ socket on the CU310 PN Control Unit.

Power Modules in chassis format are driven by the CU310 DP Control Unit via the DRIVE-CLiQ interface. With this option, Sensor and Terminal Modules must be connected to the free DRIVE-CLiQ sockets on the Power Module.

Parameter settings can be changed with the BOP20 Basic Operator Panel. The BOP20 panel can also be snapped onto the CU310 PN Control Unit during operation to perform troubleshooting procedures.

The CU310 PN Control Unit and other connected components are commissioned and diagnosed with the STARTER commissioning tool.

A CU310 PN Control Unit communicates with the higher-level control system using PROFINET IO and the PROFIdrive V4 profile.

The integrated safety functions such as e.g. "Safe Torque Off" (= "Safe standstill") must be selected in two channels. Two digital inputs on the CU310 PN Control Unit are required for this purpose.

An external 24 V supply can be connected to the CU310 to power the control unit when the incoming supply to the Power Module is not energized.

Integration (continued)

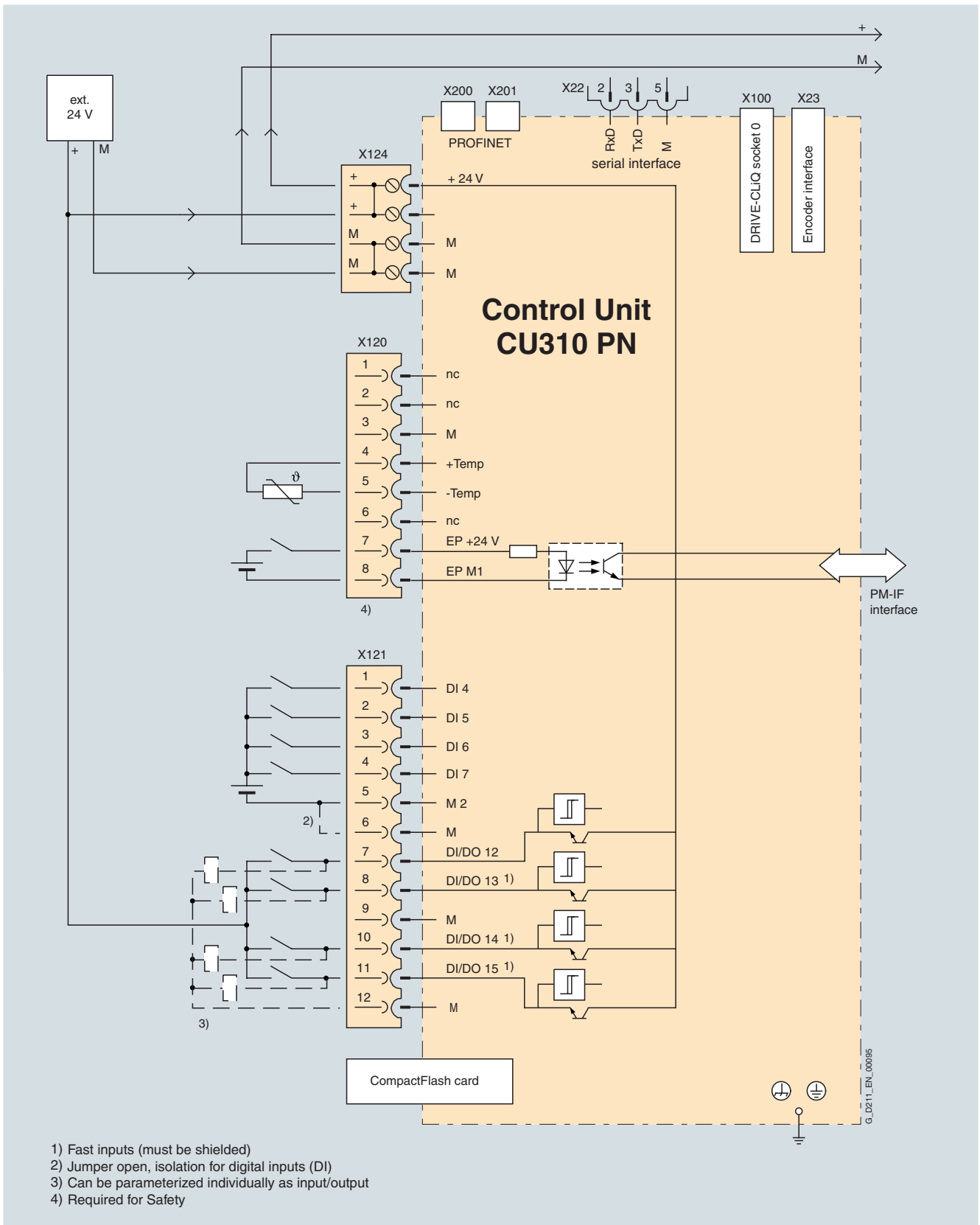

Connection example of CU310 PN Control Unit

SINAMICS S120

Control Units

CU310 PN Control Unit

Technical data

CU310 PN Control Unit

Max. current requirement (at 24 V DC) without taking account of digital outputs and DRIVE-CLiQ supply	0.9 A
Max. connectable cross section	2.5 mm ²
Max. fuse protection	20 A
Digital inputs	4 x floating digital inputs 4 bidirectional non-floating digital inputs/digital outputs
<ul style="list-style-type: none"> • Voltage • Low level (an open digital input is interpreted as "low") • High level • Current consumption (typ. at 24 V DC) • Signal propagation delays for digital inputs ¹⁾ 	– 3 V to + 30 V – 3 V to + 5 V 15 V to 30 V 10 mA L → H: approx. 50 μs H → L: approx. 100 μs
<ul style="list-style-type: none"> • Signal propagation delays for high-speed digital inputs¹⁾ (high-speed digital inputs can be used for position detection) • Max. connectable cross section 	L → H: approx. 5 μs H → L: approx. 50 μs 0.5 mm ²
Digital outputs (continued-short-circuit-proof)	4 bidirectional non-floating digital inputs/digital outputs
<ul style="list-style-type: none"> • Voltage • Max. load current per digital output ²⁾ • Max. connectable cross section 	24 V DC 500 mA 0.5 mm ²
Encoder evaluation	TTL or HTL incremental encoders (with adjustable parameters)
<ul style="list-style-type: none"> • Cut-off frequency • Max. cable length for TTL incremental encoder • Max. cable length for HTL incremental encoder 	500 kHz 100 m (328 ft) (only bipolar signals permitted) 100 m (328 ft) for unipolar signals 300 m (984 ft) for bipolar signals
Power loss	< 20 W
PE connection	On housing with M5 screw
Width	73 mm (2.9 in)
Height	183.2 mm (7.2 in)
Depth	89.6 mm (3.5 in)
Weight, approx.	0.95 kg (2 lb)
Approvals	cULus (File No.: E164110)

¹⁾ The specified signal propagation delays refer to the hardware. The actual reaction time depends on the time slot in which the digital input or output is processed.

²⁾ In order to use the digital outputs, an external 24 V power supply must be connected to terminal X124.

Overview



The communication, open-loop and closed-loop control functions for one or more Motor Modules and the Line Module are executed in a CU320 Control Unit. The CU320 Control Unit is designed for multi-axis operation.

Design



CU320 Control Unit, without guard cover

CU320 Control Unit features the following interfaces as standard:

- 4 x DRIVE-CLiQ sockets for communication with other DRIVE-CLiQ devices, e.g., Motor Modules, Active Line Modules, Sensor Modules, Terminal Modules
- 1 PROFIBUS interface with PROFIdrive V4 profile
- 8 parameterizable digital inputs (floating)
- 8 parameterizable bidirectional digital inputs/digital outputs (non-floating), of which 6 are high-speed digital inputs
- 1 serial RS232 interface
- 1 interface for the BOP20 Basic Operator Panel
- 1 slot for the CompactFlash Card on which firmware and parameters are stored
- 1 slot for mounting an option module (e.g. TB30 Terminal Board)
- 3 test sockets and one reference ground for commissioning support
- 1 connection for the electronics power supply via the 24 V DC power supply connector
- 1 PE (protective earth) connection
- 1 ground connection

A shield connection for the signal cable shield on the option module is located on the CU320 Control Unit.

The available option slot is used to expand the interfaces, for example, to include additional terminals or for communication purposes.

The status of the CU320 Control Unit is indicated via multi-color LEDs.

As the firmware and parameter settings are stored on a plug-in CompactFlash card, the Control Unit can be changed without the need for software tools.

The CU320 Control Unit can be mounted on the side of the Line Module in booksize format via brackets integrated in a Line Module. The CU320 Control Unit can also be fixed to the wall of the control cabinet using the integrated fixing lugs. As the CU320 Control Unit is not as deep as the Line Modules, suitable spacers are available to increase the depth of the CU320 Control Unit to 270 mm (10.63 in).

Integration

DRIVE-CLiQ components, for example, Motor Modules and Active Line Modules, can be connected to a CU320 Control Unit. The number of modules depends on the performance required, including duty type and additional functions.

The BOP20 panel can also be snapped onto the CU320 Control Unit during operation to perform troubleshooting procedures.

The CU320 Control Unit and other connected components are commissioned and diagnosed with the STARTER commissioning tool.

Communication between a CU320 Control Unit and the connected components takes place via DRIVE-CLiQ.

If an application requires more than one Control Unit, the number can be increased accordingly. The Control Units are then interconnected on a higher-level controller via PROFIBUS with the PROFIdrive V4 profile.

The integrated safety functions such as e.g. "Safe brake control" ("Safe standstill") must be selected in two channels. Two digital inputs are required for this purpose.

SINAMICS S120

Control Units

CU320 Control Unit

Integration (continued)

2

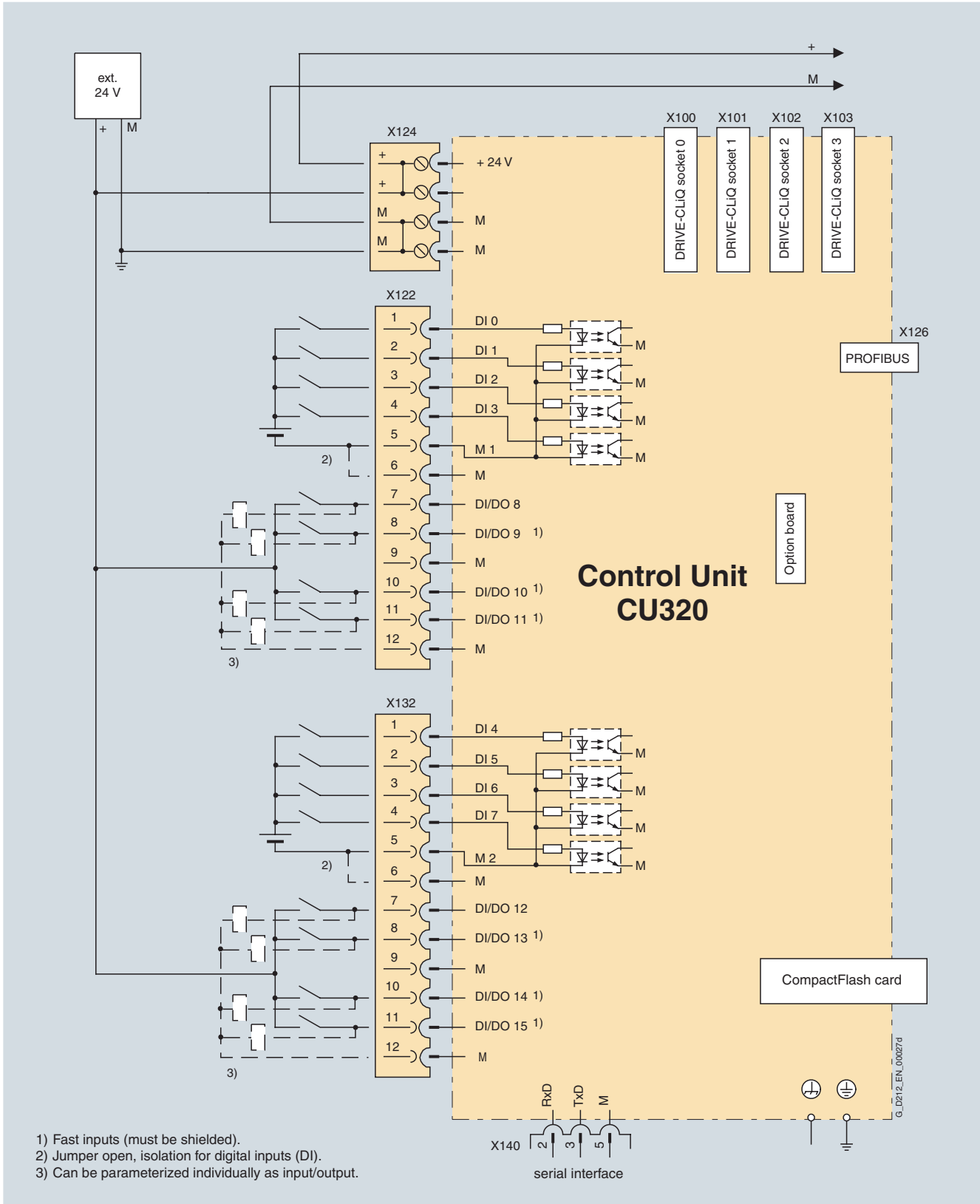

Connection example of CU320 control unit

Technical data

CU320 Control Unit

Max. current requirements (at 24 V DC) without taking account of digital outputs, option slot expansion and DRIVE-CLiQ supply	0.8 A
Max. connectable cross section	2.5 mm ²
Max. fuse protection	20 A
Digital inputs	8 x floating digital inputs 8 bidirectional non-floating digital inputs/digital outputs
• Voltage	– 3 V to 30 V
• Low level (an open digital input is interpreted as "low")	– 3 V to 5 V
• High level	15 V to 30 V
• Current consumption (typ. at 24 V DC)	10 mA
• Signal propagation delays for digital inputs ¹⁾	L → H: approx. 50 μs H → L: approx. 100 μs
• Signal propagation delays for high-speed digital inputs ¹⁾ (high-speed digital inputs can be used for position detection)	L → H: approx. 5 μs H → L: approx. 50 μs
• Max. connectable cross section	0.5 mm ²
Digital outputs (continued-short-circuit-proof)	8 bidirectional non-floating digital inputs/digital outputs
• Voltage	24 V DC
• Max. load current per digital output	500 mA
• Max. connectable cross section	0.5 mm ²
Power loss	20 W
PE connection	On housing with M5 screw
Ground connection	On housing with M5 screw
Width	50 mm (1.97 in)
Height	270 mm (10.93 in)
Depth	226 mm (8.9 in)
Weight, approx.	1.5 kg (3 lb)
Approvals	cULus (File No.: E164110)

Selection and ordering data

Description	Order No.
CU320 Control Unit (without CompactFlash card)	6SL3040-0MA00-0AA1

Accessories

Description	Order No.
PROFIBUS connector <u>without</u> PG/PC connection	6ES7972-0BA41-0XA0
PROFIBUS connector <u>with</u> PG/PC connection	6ES7972-0BB41-0XA0
Spacers (2 x), for increasing the depth of the CU320 Control Unit to 270 mm (10.63 in) (if the brackets on the side are not to be used, the depth still has to be 270 mm (10.63 in)).	6SL3064-1BB00-0AA0
STARTER commissioning tool	6SL3072-0AA00-0AG0

¹⁾ The specified signal propagation delays refer to the hardware. The actual reaction time depends on the time slot in which the digital input or output is processed.

SINAMICS S120

Control Units

CompactFlash Card for CU310 and CU320

Overview



The CompactFlash card contains the firmware and parameter settings. It is inserted into the appropriate slot on the CU310 or CU320 Control Unit.

Design

A CU320 Control Unit can perform the communication, open-loop and closed-loop control functions for several Motor Modules. The computing capacity requirement increases in proportion to the number of connected Motor Modules and system components and in relation to the dynamic response required. The full computing capacity of the CU320 Control Unit is only available on systems with performance expansion 1.

The computing capacity requirement and utilization of the CU320 Control Unit can be calculated with the SIZER configuration tool. The firmware options are supplied in license form, which are written to the CompactFlash card in the factory as license codes.

The firmware options can also be enabled on-site, for example, if the performance expansions required are not known at the time of placing the order. You will need the serial number of the CompactFlash card and the order number of the firmware option to be enabled. With this information, you can purchase the associated license code from a license database and enable the firmware option. The license code is only valid for the CompactFlash card declared and cannot be transferred to other CompactFlash cards.

The CU310 Control Unit has been designed to control only single axes. Performance expansion 1 is not required in this case.

Selection and ordering data

Description	Order No.
CompactFlash card for CU310 DP, CU310 PN, CU320 Control Units with current firmware version including certificate of license	
• <u>without</u> performance expansion	6SL3054-0AA00-1AA0
• <u>with</u> performance expansion 1 firmware option	6SL3054-0AA01-1AA0
Firmware license Performance expansion 1 firmware option for CompactFlash card including certificate of license	6SL3074-0AA01-0AA0

Further information

Firmware version

The firmware version is encoded in the order (part) number of the CompactFlash card supplied. For the above order number the most recent firmware version is always installed on shipped CompactFlash cards, i.e. the order number on the shipped CompactFlash cards may not necessarily match the order number of the ordered CompactFlash cards.

The firmware version is encoded as follows in the order number:

Order No.	6SL3054- 0 ■ ■ 0 ■ -1AA0	
Firmware version		↑
1	B	
2	C	
3	D	
4	E	
Version		↑
.1	B	
.2	C	
.3	D	
.4	E	
.5	F	
.6	G	
without performance expansion		↑
	0	
with performance expansion 1		↑
	1	

Example: A CompactFlash card with the order number 6SL3054-0AA00-1AA0 is ordered (as specified in the catalog). The CompactFlash card with the most recent firmware version is confirmed and shipped, e.g. order number 6SL3054-0CE00-1AA0 for firmware version 2.4. In this way, it is possible to specify a specific firmware version or the most recent firmware version in a replacement part order.

Overview

SIMOTION D is the compact, drives-based version of SIMOTION based on the SINAMICS drives family. With SIMOTION D, the logic, technology functions, motion control and drive control run on a single, compact hardware platform.

SIMOTION D is available in different performance variants. This ensures the highest degree of scalability and flexibility. The IEC 61131-3-compliant PLC integrated in SIMOTION D means that the system is not just capable of controlling sequences of motions, but the entire machine as well.

HMI devices can be connected via the onboard PROFIBUS or Ethernet interface for operator control and monitoring. Functions such as remote maintenance, diagnostics and teleservice can also be used via these interfaces.

Function

The SIMOTION D controllers basic functionality is supplied with the CompactFlash card and is loaded when the system is powered on. The basic scope of functions includes the following software components:

- SINAMICS S120 drive control
- SIMOTION runtime system
 - Programmable with several languages conforming to IEC 61131
 - Various runtime levels (cyclic, sequential, event-driven)
 - PLC and arithmetic functionality
 - Communications and management functions
 - Motion control functions (Motion Control Basic)
- Test and diagnostic interfaces

Technology packages (TP)

A special feature of SIMOTION is that the basic functionality can be expanded by loading technology packages, such as:

- Motion control with technology packages:
 - Positioning – POS
 - Synchronous operation/electronic gear – GEAR
 - Cam disk – CAM
- Temperature controller – TControl

Since the technology functions have modular licenses, you only pay for what you really need.

SINAMICS S120

Control Units

SIMOTION D Control Units

Overview



SIMOTION D Control Units are available in a range of performance variants. This ensures the highest degree of scalability and flexibility. The individual variants SIMOTION D425, SIMOTION D435 and SIMOTION D445 differ in terms of performance characteristics (Motion Control + PLC) and the following features:

	SIMOTION D425	SIMOTION D435	SIMOTION D445
Maximum number of axes	16	32	64
DRIVE-CLiQ interfaces	4	4	6
Fan/battery module	Option	Option	required

Additional drives can be operated by means of PROFIBUS or PROFINET with the CU320 Control Units. Additional drives can also be directly connected to the SIMOTION D445 Control Unit by means of DRIVE-CLiQ with the SIMOTION CX32 module.

The drives can operate in Servo, Vector or *V/f* control mode.

Design

Interfaces

- Displays, diagnostics
 - LEDs to display operating states and errors
 - 7-segment status/error display during system power-up
 - 3 test sockets
- Interfaces
 - 4 × DRIVE CLiQ (6 × DRIVE CLiQ for SIMOTION D445)
 - 2 × Industrial Ethernet
 - 2 × PROFIBUS DP
- Integrated I/Os
 - 8 digital inputs
 - 8 digital inputs/outputs
- Various
 - Terminals for 24 V electronics power supply
 - Slot (Option slot) to receive a terminal expansion or additional communications ports

Data storage/data backup

SIMOTION D425, D435 and D445 Control Units have 320 KB of non-volatile SRAM (battery-backed for at least 5 days) for process variable storage. There are two options for storing data for a longer period:

- System commands for storing data on the SIMOTION CompactFlash card (CF)
- Use of a battery module

The CompactFlash card stores the runtime software and the user data and programs.

I/O

PROFIBUS DP

- Certified PROFIBUS standard slaves (DP/V0, DP/V1, DP/V2)
- SIMATIC ET 200S/M/X/eco/pro distributed I/O systems

DRIVE-CLiQ

- Modules from the SINAMICS range
- DRIVE-CLiQ cables, which are required to connect Line/Motor Modules to SIMOTION D, are supplied with the Line/Motor Modules (standard length).

Integration

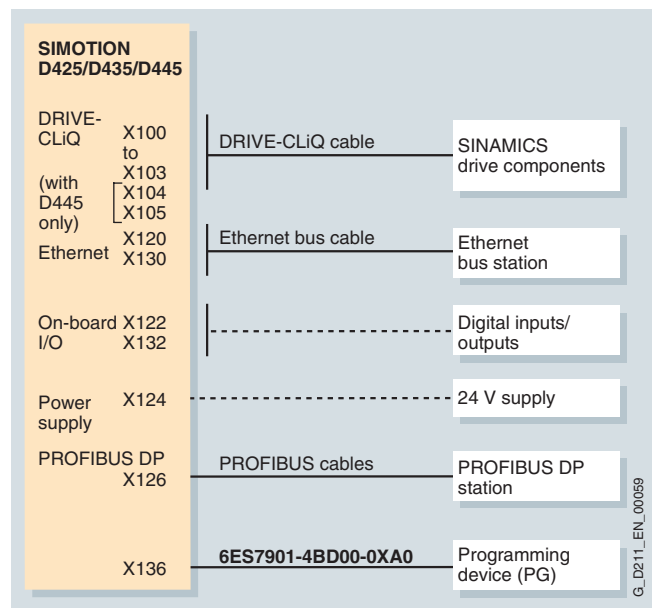

Connection overview of SIMOTION D425, D435, D445

The maximum permissible cable lengths should be taken into account when planning the cable layout.

Malfunctions may occur if longer lengths are used.

The permissible length of PROFIBUS DP cables depends on the configuration.

Technical data

		SIMOTION D425 Control Unit Basic Performance 6AU1425-0AA00-0AA0	SIMOTION D435 Control Unit Standard Performance 6AU1435-0AA00-0AA1	SIMOTION D445 Control Unit High Performance 6AU1445-0AA00-0AA0
Power supply				
• Rated value	V DC	24	24	24
• Permissible range	V	20.4 to 28.8	20.4 to 28.8	20.4 to 28.8
Current consumption (at 24 V DC), not taking into account digital outputs, typ.	A	0.6	0.6	2
Inrush current, typ.	A	6	6	6
Power loss	W	15	15	50
Permissible ambient temperature				
• Storage and transport	°C	- 40 to + 70 (- 40 °F to +158 °F)	- 40 to + 70 (- 40 °F to +158 °F)	- 40 to + 70 (- 40 °F to +158 °F)
• Operation	°C	0 to +55 (32 °F to +131 °F)	0 to +55 (32 °F to +131 °F)	0 to +55 (32 °F to +131 °F)
Permissible relative humidity (without condensation)	%	5 to 95	5 to 95	5 to 95
Air pressure	hPa	700 to 1060	700 to 1060	700 to 1060
Degree of protection to IEC 529		IP20	IP20	IP20
Width	mm	50 (1.97 in)	50 (1.97 in)	50 (1.97 in)
Height	mm	380 (14.96 in)	380 (14.96 in)	380 (14.96 in)
Depth	mm	230 (9.1 in)	230 (9.1 in)	270 (10.6 in)
Weight				
• SIMOTION D	kg	2.5 (5 lb)	2.5 (5 lb)	3.6 (8 lb)
• CompactFlash card	g	7 (0.02 lb)	7 (0.02 lb)	7 (0.02 lb)
Digital inputs		8	8	8
Rated value	V DC	24	24	24
• For signal "1"	V	15 to 30	15 to 30	15 to 30
• For signal "0"	V	- 3 to + 5	- 3 to + 5	- 3 to + 5
Isolation		Yes, in groups of 4	Yes, in groups of 4	Yes, in groups of 4
Current consumption at 24 V, typ. for signal level 1	mA	10	10	10
Signal propagation delays	µs	100	100	100
Digital inputs/outputs (parameterizable)		8	8	8
When used as an input				
• Input voltage				
- Rated value	V DC	24	24	24
- For signal "1"	V	15 to 30	15 to 30	15 to 30
- For signal "0"	V	- 3 to + 5	- 3 to + 5	- 3 to + 5
• Isolation				
		No	No	No
• Current consumption at 24 V, typ. for signal level 1	mA	10	10	10
• Signal propagation delays	µs	100 (1 µs as measuring probe)	100 (1 µs as measuring probe)	100 (1 µs as measuring probe)
When used as an output				
• Rated load voltage				
- Rated value	V DC	24	24	24
- Permissible range	V	20.4 to 28.8	20.4 to 28.8	20.4 to 28.8
• Output voltage				
- For signal "1", max.	V	15 to 30	15 to 30	15 to 30
• Isolation				
		No	No	No
• Current load, max.	mA	500 per output	500 per output	500 per output
• Residual current, max.	mA	2	2	2
• Switching frequency of the outputs				
- With ohmic load	Hz	100	100	100
- With inductive load	Hz	2	2	2
• Short-circuit protection		yes	yes	yes
Real-time clock/SRAM backup				
• Backup time, min.		5 days	5 days	5 days
• Charging time, typ.		Only a few minutes	Only a few minutes	Only a few minutes
Approvals		cULus (File No.: E164110)	cULus (File No.: E164110)	cULus (File No.: E164110)

SINAMICS S120

Control Units

SIMOTION D Control Units

Selection and ordering data

Description	Order No.
Control Unit <ul style="list-style-type: none">• SIMOTION D425• SIMOTION D435• SIMOTION D445	6AU1425-0AA00-0AA0 6AU1435-0AA00-0AA1 6AU1445-0AA00-0AA0
CompactFlash card 512 MB with SINAMICS drive software version V2.4 and SIMOTION kernel	6AU1400-2NA00-0AA0
Spacers (for D425 and D435; included as standard with D445) Kit, 2 spacers	6SL3064-1BB00-0AA0
Battery	6FC5247-0AA18-0AA0
Battery and fan module for non-volatile data storage (optional for D425 and D435; required for D445)	6FC5348-0AA01-0AA0

Further information

Further information

- on PROFIBUS DP and Industrial Ethernet can be found in Catalog IK PI or in the Interactive Catalog under "Automation Systems/SIMATIC NET Communication Systems" and under "Communication".
- on the SIMOTION Motion Control System Catalog PM10 can be found

SIMOTION CX32 Controller Extension

Overview



The CX32 Controller Extension is a SINAMICS S120-type component and permits the drive-side computing power for the SIMOTION D product range to be scaled. Each CX32 can control up to six additional servo axes.

The controller is connected to SIMOTION D with DRIVE-CLiQ which ensures high-performance isochronous drive control without additional modules. The communication interfaces on the SIMOTION D modules remain available for other connections. With a width of 25 mm (0.98 in) the module requires very little space and is therefore perfectly suited for use in compact machines.

The data for the SIMOTION CX32 is stored exclusively on the SIMOTION D module which means no action has to be taken if the module is replaced. The SIMOTION CX32 can be operated on the SIMOTION D445 and D435 Control Units.

Design

Automation solutions with many axes can be implemented with SIMOTION D and the SIMOTION CX32 Controller Extension. SIMOTION D can manage and control the motion of up to 64 axes and already has the drive control for up to 6 servo axes plus the infeed integrated. Alternatively, vector axes or *V/f* axes can be operated. The drive control for up to 6 additional servo axes can be implemented with the SIMOTION CX32 Controller Extension. More than one SIMOTION CX32 Controller Extension can be used in an axis group.

Additional CU320s can be operated via PROFIBUS on a SIMOTION D425, D435 or D445.

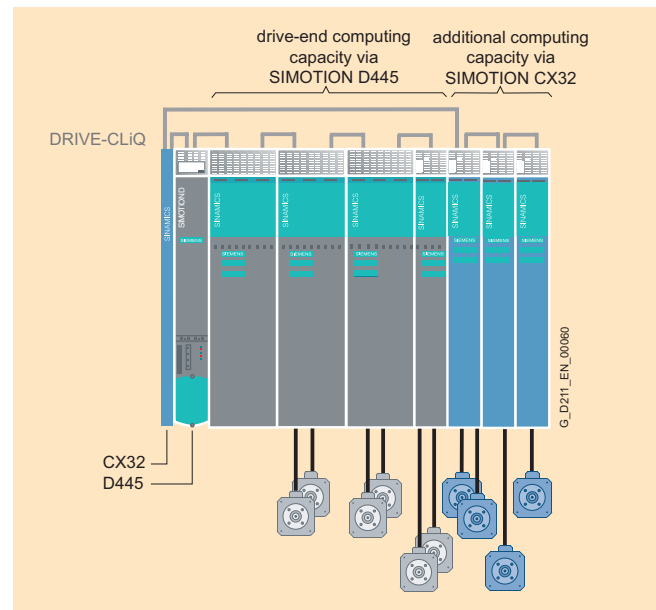

Example of an axis group for 10 axes

Technical data

SIMOTION CX32 Controller Extension	
Power supply	
• Rated value	24 V DC
• Permissible range	20.4 V to 28.8 V
Current consumption (at 24 V DC) without taking account of digital outputs and DRIVE-CLiQ supply, typ.	0.8 A
Inrush current, typ.	1.6 A
Permissible ambient temperature	
• Storage and transport	- 40 °C to +70 °C (- 40 °F to +158 °F)
• Operation	0 °C to + 55 °C (32 °F to +131 °F)
Permissible relative humidity (without condensation)	5% to 95%
Air pressure	700 to 1060 hPa
Degree of protection to IEC 529	IP20
Width	25 mm (0.98 in)
Height	380 mm (14.96 in)
Depth	230 mm (9.1 in)
Weight	1.5 kg (3 lb)
Approvals	cULus (File No.: E164110)
Digital inputs	4
Digital inputs/outputs	4, programmable

Selection and ordering data

Description	Order No.
SIMOTION CX32 Controller Extension	6SL3040-0NA00-0AA0

SINAMICS S120

Engineering software

STARTER drive/commissioning software

Overview

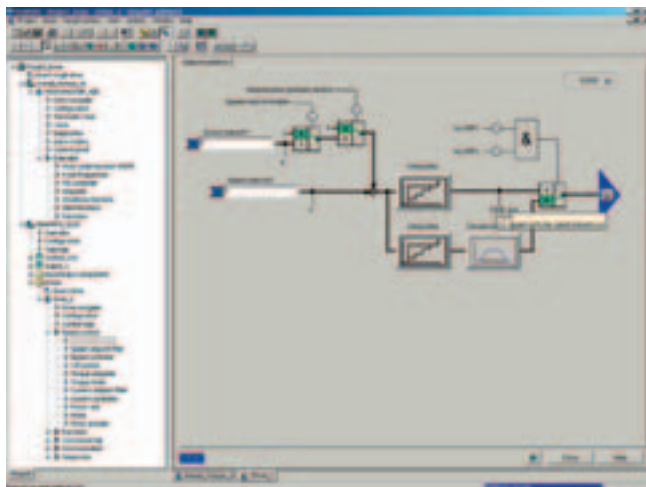

The easy-to-use STARTER drive/commissioning software can be used for:

- commissioning,
- optimization and
- diagnostics.

This software can be operated either as a standalone PC application or can be integrated into the SCOUT engineering system (on SIMOTION) or STEP 7 (with Drive ES Basic). The basic functions and handling are the same in both cases.

In addition to the SINAMICS drives, the current version of STARTER also supports MICROMASTER 4 devices and inverters for the SIMATIC ET 200S FC distributed I/O system.

The project wizards can be used to create the drives within the structure of the project tree.

First-time users are supported by solution-based dialog menu, whereby a standard graphics-based display maximizes clarity when setting the drive parameters.

First commissioning is guided by wizards, which make all the basic settings in the drive. This enables a drive to be up and running after only setting a small number of parameters within the drive configuration process.

The individual settings required are made using graphics-based parameterization screenforms, which also display the mode of operation.

Examples of individual settings that can be made include:

- terminals
- bus interface
- setpoint channel (e.g. fixed setpoints)
- speed control (e.g. ramp-function generator, limits)
- BICO interconnections
- diagnostics

Experts can gain rapid access to the individual parameters via the expert list and do not have to navigate dialogs.

In addition, the following functions are available for optimization purposes:

- self-optimization
- trace (depending on drive)

Diagnostics functions provide information about:

- control/status words
- parameter status
- operating conditions
- communication states

Performance

- Easy to use: only a small number of settings need to be made for successful first commissioning: axis turning
- Solution-based dialog-based user guidance simplifies commissioning
- Self-optimization functions reduce manual effort for optimization.
- The built-in trace function provides optimum support during commissioning, optimization and troubleshooting.

Minimum hardware and software requirements

PG or PC with Pentium™ II 400 MHz (Windows™ 2000), Pentium™ III 500 MHz (Windows™ XP)

256 MB RAM (512 MB recommended)

Monitor resolution, 1024 × 768 pixels

Windows™ 2000 SP3, XP Professional SP1

Microsoft Internet Explorer 5.01

Integration

A PROFIBUS Communication Module and a connection cable are required to make the communication link between the PG/PC and a Control Unit.

For example, PROFIBUS Communication Module CP 5512 (PCMCIA type 2 card + adapter with 9-pole SUB-D socket for connection to PROFIBUS). For Windows 2000/XP Professional and PCMCIA 32)

Order No.: 6GK1551-2AA00

and connection cable between CP 5512 and PROFIBUS

Order No.: 6ES7901-4BD00-0XA0

PC converter connection sets are available for MICROMASTER 4, SINAMICS G110 and SINAMICS G120 for a safe point-to-point connection to the PC.

Order No. for MICROMASTER 4: 6SE6400-1PC00-0AA0

(the scope of supply includes a 9-pole SUB-D connector and an RS 232 standard cable, 3 m (9.8 ft))

Order No. for SINAMICS G110 and SINAMICS G120:

6SL3255-0AA00-2AA1

(the scope of supply includes a 9-pole SUB-D connector and an RS 232 standard cable, 3 m (9.8 ft), and the STARTER startup tool on CD-ROM)

Selection and ordering data

Description	Order No.
STARTER commissioning tool for SINAMICS and MICROMASTER English/German/French/Italian	6SL3072-0AA00-0AG0

Overview

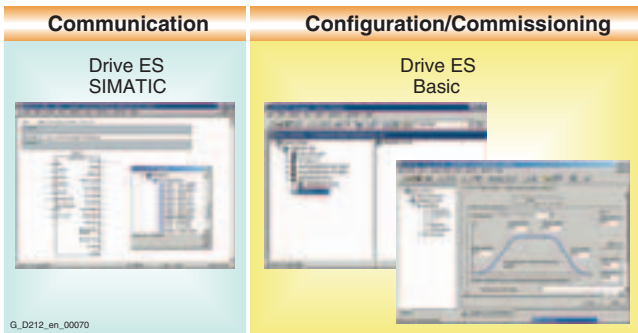

Drive ES is the engineering system used to integrate Siemens drive technology into the SIMATIC automation world easily, efficiently and cost-effectively in terms of communication, configuration and data management. The STEP 7 Manager user interface provides the basis for this procedure.

Various software packages are available for SINAMICS:

- **Drive ES Basic**
for first-time users of the world of Totally Integrated Automation and the option for routing beyond network limits along with the use of the SIMATIC teleservice.
Drive ES Basic is the basic software program for setting the parameters of all drives online and offline.
Drive ES Basic enables both the automation system and drives to be handled via the SIMATIC Manager user interface.
Drive ES Basic is the starting point for common data archiving for complete projects and for extending the use of the SIMATIC teleservice to drives. Drive ES Basic provides the configuration tools for the new Motion Control functions slave-to-slave communication, equidistance and isochronous operation with PROFIBUS DP.
- **Drive ES SIMATIC**
simple parameterization of the STEP 7 communication instead of programming.
In order to use Drive ES SIMATIC, STEP 7 must be installed. It features a SIMATIC function block library, thereby making the programming of the PROFIBUS interface in the SIMATIC CPU for the drives easy and secure. There is no need for separate, time-consuming programming of the data exchange between the SIMATIC CPU and the drive.
All Drive ES users need to remember is:
Copy – Modify – Download – Ready.
Customized, fully-developed function blocks are copied from the library into user-specific projects.
Frequently-used functions are set to run in program format:
 - Read out complete diagnostics buffer automatically from the drive
 - Download complete parameter set automatically from the SIMATIC CPU into the drive – e.g. when a device has to be replaced.
 - Load part parameter sets (e.g. for recipe and product change) automatically from the SIMATIC CPU
 - Read back, i.e. update, complete parameterization or part parameter sets are uploaded from the drive into the SIMATIC CPU.
- **Drive ES PCS 7**
integrates drives with the PROFIBUS interface into the SIMATIC PCS 7 process control system.
Drive ES PCS 7 can only be used with SIMATIC PCS 7 Version 5.2 and higher. Drive ES PCS 7 provides a function block library with function blocks for the drives and the corresponding faceplates for the operator station, which enables the drives to be operated from the PCS 7 process control system.

For further information please visit us on the Internet at:

<http://www.siemens.com/drivesolutions>

Selection and ordering data

Description	Order No.
Drive ES Basic V 5.4	
<ul style="list-style-type: none"> • Configuration software for the integration of drives into Totally Integrated Automation • Requirement: STEP 7 V5.3 and higher, SP3 • Supply format: on CD-ROM Ger., Eng., Fr., Sp., It. with electronic documentation 	
Single-user license	6SW1700-5JA00-4AA0
Multi-user license, 60x	6SW1700-5JA00-4AA1
Update service for single-user license	6SW1700-0JA00-0AB2
Update service for multi-user license	6SW1700-0JA00-1AB2
Upgrade from V 5.x to V 5.4	6SW1700-5JA00-4AA4
Drive ES SIMATIC V 5.4	
<ul style="list-style-type: none"> • Function block library for SIMATIC for the parameterization of communication with the drives • Requirement: STEP 7 V5.3 and higher, SP3 • Supply format: on CD-ROM Ger., Eng., Fr., Sp., It. with electronic documentation 	
Single-user license, incl. 1 x runtime license	6SW1700-5JC00-4AA0
Runtime license	6SW1700-5JC00-1AC0
Update service for single-user license	6SW1700-0JC00-0AB2
Upgrade from V 5.x to V 5.4	6SW1700-5JC00-4AA4
Drive ES PCS 7 V 6.1	
<ul style="list-style-type: none"> • Function block library for PCS 7 for the integration of drives • Requirement: PCS 7 V 6.1 and higher • Supply format: on CD-ROM Ger., Eng., Fr., Sp., It. with electronic documentation 	
Single-user license, incl. 1 x runtime license	6SW1700-6JD00-0AA0
Runtime license	6SW1700-5JD00-1AC0
Update service for single-user license	6SW1700-0JD00-0AB2
Upgrade from V 5.x to V 6.1	6SW1700-6JD00-0AA4

Overview

The SCOUT engineering software enables the solution of Motion Control, PLC and technology tasks in the SIMOTION Motion Control system and supplies all tools for this purpose, such as programming and parameterization, testing and commissioning, as well as diagnostics.

The SIMOTION D Control Units contain as standard a basic functionality (Kernel), which is programmable in accordance with IEC 61131.

Loadable technology packages provide further functionalities, such as positioning, synchronous operation, electronic cams and temperature channels.

These technology packages enable the creation of technological objects, which offer an easy and overall view of associated functions.

There are various technological objects, which are all created, configured and parameterized in the same way.

Additionally the technological objects comprise of a programming interface, making it possible to use the functionality out of the user program.

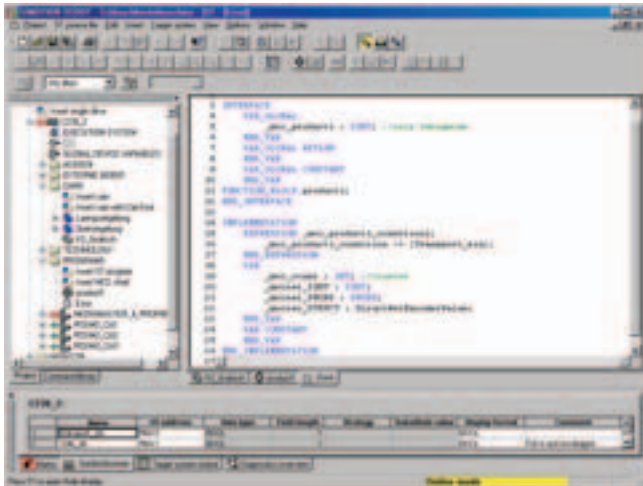

The high-level language Structured Text (ST) provides all language resources in the form of commands. This permits the generation of well-structured applications.

The basic commands implement all requirements for:

- data management,
- computing functions,
- control structures
- I/O operations

The addition of the technology packages for Motion Control increases the scope of commands by adding powerful, highly flexible Motion Control commands (e. g.: `_pos(...)` for position controlled axis positioning).

An ST source file basically consists of continuous text. This text can be divided and structured in sections, which represent logical sections of an ST source file.

These sections can consist of the following:

- Program assigned to a runtime task
- Function block with a dedicated memory
- Function without a dedicated memory

Functions and function blocks are not assigned to a runtime task. They are called from programs.

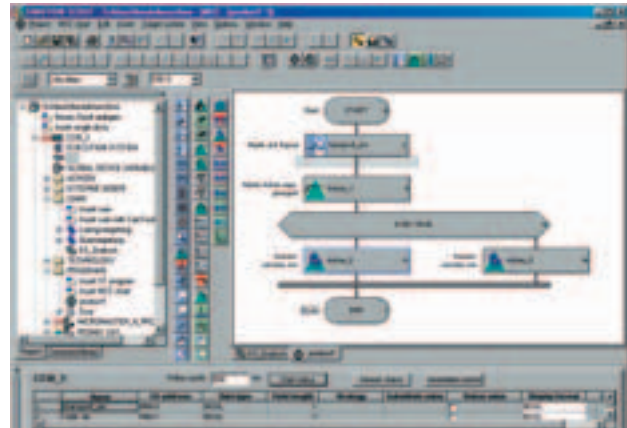

Motion Control Chart (MCC) can be used to formulate the processes of a machine graphically with simple and logical tools. The result is one or more flowcharts showing the chronological sequence of the individual actions.

Above all, MCC supports the simple description of the motion sequences of machines with many axes with the help of powerful Motion Control commands (e. g. reference axis, position axis, synchronize or desynchronize cam, and many more).

Different commands are available for controlling the machine, e. g. if conditions must be fulfilled, I/O signals can be read or set, calculations can be formulated and different control structures such as condition (IF), cases (CASE) and loops (WHILE, REPEAT UNTIL) can be programmed.

Several MCC programs may be created to describe different process situations. For example, you can create one MCC program to bring the machine to a defined initial state when it is powered on, a second MCC program for the normal production sequence, and a third MCC program to specify what the machine is to do in the event of a fault.

All commands are available in tool bars (sorted according to functions) and are automatically inserted in the flowchart at the selected point with a click. By clicking on different elements, individual dialogs for further parameterization are opened. Of course, it is also possible to include individual comments to document the sequence.

Further information

Further information on characteristics of the SCOUT engineering software, as well as of hardware platforms, runtime software and ordering data of the SIMOTION Motion Control system can be found in Catalog PM10.

Design



PM340 Power Modules in blocksize format, frame sizes FSA to FSF

The PM340 Power Modules in blocksize format feature the following connection as standard:

- Supply Connection
- DCP/R1 and DCN DC link terminal
- Terminals DCP/R1 and R2 for connection of an external braking resistor
- PM-IF interface for connection of the PM340 Power Module and CU310 Control Unit or CUA31 Control Unit Adapter. The PM340 Power Module also supplies power to the CU310 Control Unit or CUA31 Control Unit Adapter by means of an integrated power supply
- Motor connection made with screw terminals or screw studs
- Control circuit for the Brake Relay or Safe Brake Relay to control a holding brake
- 2 PE (protective earth) connections

Power Modules without integrated line filter are suitable for connection to both grounded-neutral (TN, TT) and non-grounded (IT) systems.

Power Modules with integrated line filter are suitable only for connection to TN systems.

When utilizing the integrated Braking Unit (Braking Chopper), the temperature of the external braking resistor must be monitored (i.e. thermostatic switch) to provide protection against thermal overloading.

Integration



PM340 Power Module in blocksize format with CU310 DP Control Unit



PM340 Power Module in blocksize format with CUA31 Control Unit Adapter

Integration (continued)

Many system components for PM340 Power Modules are designed as base components, i.e. the component is mounted on the baseplate and the PM340 Power Module in front of them in a space-saving construction. Up to two base components can be mounted in front of one another.

	FSA	FSB	FSC	FSD	FSE	FSF
Line filter	✓					
Line reactor	✓	✓	✓	✓	✓	–
Braking resistor	✓	✓	–	–	–	–
Motor reactor	✓	✓	✓	–	–	–

- ✓ suitable as base type
- not suitable as base type
- not available

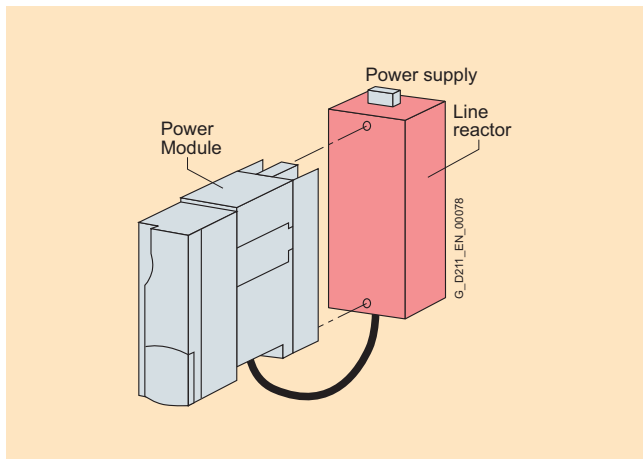

Basic layout of a PM340 Power Module with line reactor as base component

The line-side reactors are equipped with terminals on the line side and with a pre-assembled cable on the Power Module side. When installed, the mains terminals are at the top on frame sizes FSA to FSC, and at the bottom on frame sizes FSD and FSE.

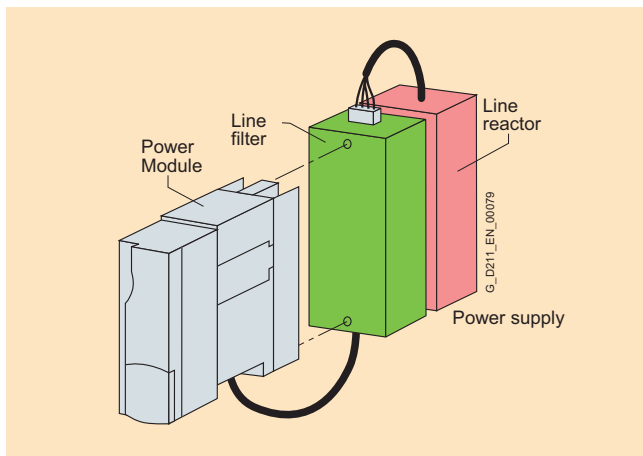

Power Module PM340 frame size FSA with line reactor and line filter

If a line filter is installed in addition to the line reactor on frame size FSA, the components must be arranged as shown in the diagram above. In this case, the mains connection is at the bottom.

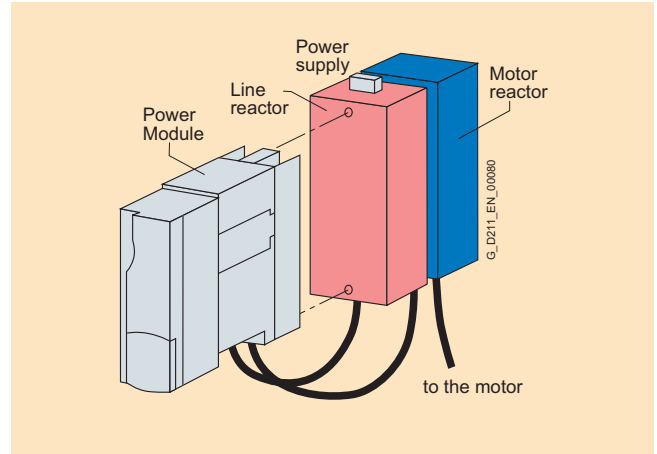

Power Module PM340 frame size FSA with line reactor and motor reactor

Power Modules of frame size FSB and higher are available with integrated line filters, alleviating the need for an external line filter.

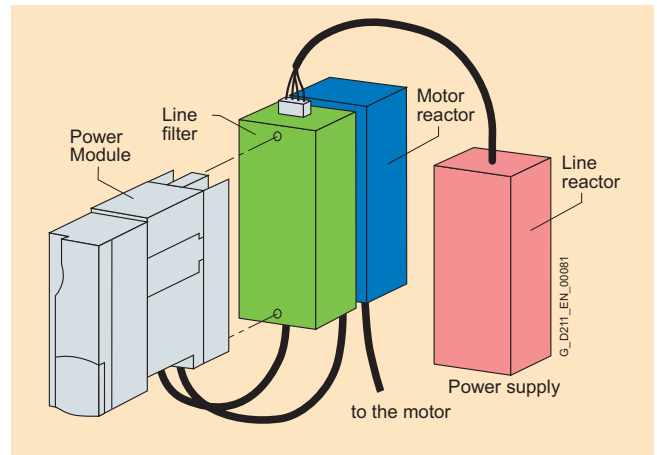

For configurations involving more than two base-type system components, e.g. line reactor + motor reactor + braking resistor, individual components must be mounted to the side of the Power Module. In this instance, the line and motor reactors must be installed behind the Power Module and the braking resistor to the side.

Integration (continued)

The PM340 Power Modules in blocksize format communicate with the CU310 Control Unit or the CUA31 Control Unit Adapter via the PM-IF interface.

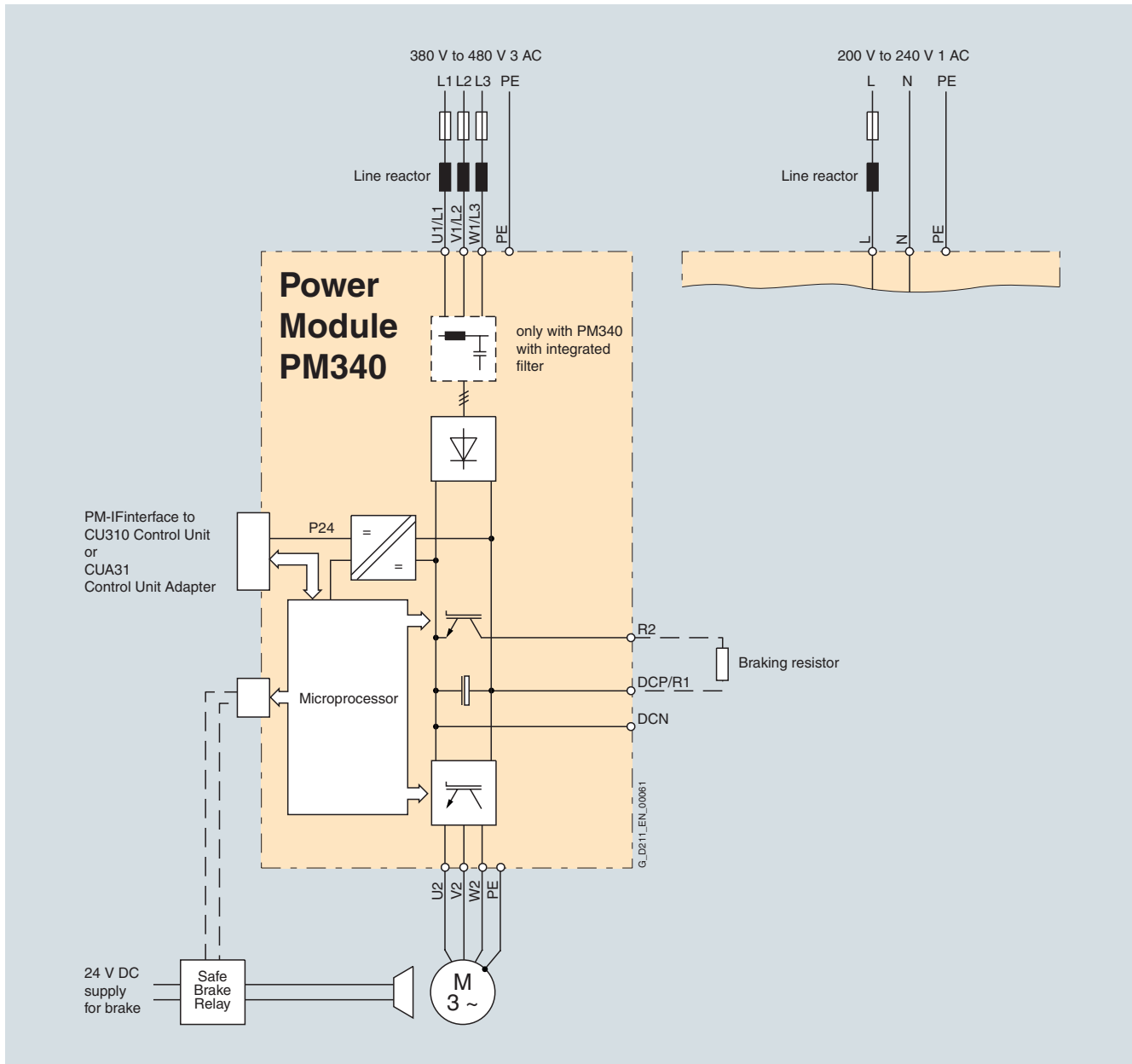

Connection example of PM340 Power Module in blocksize format

SINAMICS S120

Power Modules and line-side components

Power Modules in blocksize format

Technical data

General technical data

Electrical data	
Line connection voltage (up to 2000 m (6563 ft) above sea level)	200 V to 240 V 1 AC ±10% (– 15% < 1 min) or 380 V to 480 V 3 AC ±10% (– 15% < 1 min)
Power frequency	47 Hz to 63 Hz
Line power factor at rated output	
• Fundamental Power Factor	> 0.96
• Total (λ)	
- 200 V to 240 V 1 AC	0.45 to 0.7
- 380 V to 480 V 3 AC	0.65 to 0.95
Overvoltage category	Class III to EN 60664-1
DC link precharging frequency	max. 1x every 30 s
DC link voltage	approx. 1.35 x line voltage
Output frequency	
• Control type Servo	0 Hz to 650 Hz ¹⁾
• Control type Vector	0 Hz to 300 Hz ¹⁾
• Control type V/f	0 Hz to 300 Hz ¹⁾
Electronics power supply	24 V DC – 15%/+ 20%
Radio interference suppression	
• Standard	No radio interference suppression
• With line filter	Class A1 to EN 55011 and Category C2 to EN 61800-3
Ambient conditions	
Type of cooling	Forced air cooling through a built-in fan
Permissible ambient and coolant temperature (air) during operation for line-side components, Line Modules and Motor Modules	0°C to + 40 °C (32 °F to + 104 °F) without derating, > 40 °C to + 55 °C (> 104 °F to + 131°C) see derating characteristics
Site altitude	Up to 1000 m (3282 ft) above sea level without derating, > 1000 m to 4000 m (> 3280 ft to 13126 ft) above sea level see derating characteristics
Conformity	CE (low-voltage and EMC Directives)
Approvals	cULus
- 200 V to 240 V 1 AC	Frame size FSA (File No.: E192450)
- 380 V to 480 V 3 AC	Frame sizes FSA to FSC: (File No.: E121068) Frame sizes FSD to FSF: (File No.: E192450)
Certification (in preparation)	Safety Integrity Level 2 (SIL 2) to IEC 61508, control category 3 to EN 954-1 for Safety Integrated – safe standstill (SH) (STO = Safe Torque Off) and safe brake control (SBC) in conjunction with Safe Brake Relay

¹⁾ Note correlation between max. output frequency, pulse frequency and current derating, see System Description.

Technical data (continued)

Line voltage 200 V to 240 V 1 AC		PM340 Power Modules in blocksize format		
		6SL3210-1SB11-0...	6SL3210-1SB12-3...	6SL3210-1SB14-0...
Rated output current I_{rated}	A	0.9	2.3	3.9
Base load current I_H	A	0.8	2.0	3.4
Output current for S6 duty (40%) I_{S6}	A	1.4	3.3	5.5
Max. output current I_{max}	A	2.0	4.6	7.8
Rated power based on I_{rated}	kW (HP) ³⁾	0.12 (0.2)	0.37 (0.5)	0.75 (0.75)
Rated pulse frequency	kHz	4	4	4
Efficiency η		0.88	0.93	0.93
Power loss	kW	0.06	0.075	0.11
Cooling air requirement	m ³ /s (ft ³ /s)	0.005 (0.02)	0.005 (0.02)	0.005 (0.02)
Sound pressure level	dB(A)	< 45	< 45	< 45
24 V DC power supply for the Control Unit	A	1.0	1.0	1.0
Rated input current ¹⁾ with/without line reactor	A	1.4/2.2	4/6	6.5/10
Resistance value of the external braking resistor	Ohm	≥ 180	≥ 180	≥ 180
Max. cable length to braking resistor	m (ft)	15 (49)	15 (49)	15 (49)
Line supply connection L, N		Screw-type terminals for cable cross section 1.0 mm ² to 2.5 mm ²	Screw-type terminals for cable cross section 1.0 mm ² to 2.5 mm ²	Screw-type terminals for cable cross section 1.0 mm ² to 2.5 mm ²
Motor connection U2, V2, W2		Screw-type terminals for cable cross section 1.0 mm ² to 2.5 mm ²	Screw-type terminals for cable cross section 1.0 mm ² to 2.5 mm ²	Screw-type terminals for cable cross section 1.0 mm ² to 2.5 mm ²
DC link connection, connection for braking resistor DCP/R1, DCN, R2		Screw-type terminals for cable cross section 1.0 mm ² to 2.5 mm ²	Screw-type terminals for cable cross section 1.0 mm ² to 2.5 mm ²	Screw-type terminals for cable cross section 1.0 mm ² to 2.5 mm ²
PE connection		On housing with M4 screw	On housing with M4 screw	On housing with M4 screw
Max. motor cable length ²⁾ (without external options)	m (ft)	50 (164) shielded 75 (246) unshielded	50 (164) shielded 75 (246) unshielded	50 (164) shielded 75 (246) unshielded
Degree of protection		IP20	IP20	IP20
Width	mm (inch)	73 (2.87)	73 (2.87)	73 (2.87)
Height	mm (inch)	173 (6.81)	173 (6.81)	173 (6.81)
Depth				
• PM340 Power Module	mm (inch)	145 (5.7)	145 (5.7)	145 (5.7)
• PM340 with CU310	mm (inch)	234.6 (9.24)	234.6 (9.24)	234.6 (9.24)
• PM340 with CUA31	mm (inch)	175.3 (6.9)	175.3 (6.9)	175.3 (6.9)
Size		FSA	FSA	FSA
Weight, approx.	kg (lb)	1.2 (3)	1.3 (3)	1.3 (3)

¹⁾ The input current depends on the motor load and line impedance. The input currents apply for rated power loading (based on I_{rated}) for a line impedance corresponding to $u_k = 1\%$.

²⁾ Max. motor cable length 15 m (49 ft) (shielded) for PM340 Power Modules with integrated line filter to maintain the limit values of EN 61800-3 Category C2.

³⁾ Nominal HP based on Asynchronous motors (induction motors). For specific sizing select drive based on motor nameplate current and overload.

SINAMICS S120

Power Modules and line-side components

Power Modules in blocksize format

Technical data (continued)

Line voltage 380 V to 480 V 3 AC		PM340 Power Modules in blocksize format				
		6SL3210-1SE11-3UA0	6SL3210-1SE11-7UA0	6SL3210-1SE12-2UA0	6SL3210-1SE13-1UA0	6SL3210-1SE14-1UA0
Rated output current I_{rated}	A	1.3	1.7	2.2	3.1	4.1
Base load current I_H	A	1.1	1.5	1.9	2.7	3.6
Output current for S6 duty (40%) I_{S6}	A	1.3	2.0	2.5	3.5	4.5
Max. output current I_{max}	A	2.6	3.4	4.4	6.2	8.2
Rated power based on I_{rated}	kW (HP) ³⁾	0.37 (0.5)	0.55 (0.75)	0.75 (1)	1.1 (1.5)	1.5 (2)
Rated power based on I_H	kW (HP) ³⁾	0.37 (0.5)	0.55 (0.5)	0.75 (0.75)	1.1 (1)	1.5 (2)
Rated pulse frequency	kHz	4	4	4	4	4
Efficiency η		0.90	0.92	0.94	0.95	0.96
Power loss	kW	0.10	0.10	0.10	0.11	0.11
Cooling air requirement	m ³ /s (ft ³ /s)	0.005 (0.02)	0.005 (0.02)	0.005 (0.02)	0.005 (0.02)	0.005 (0.02)
Sound pressure level	dB(A)	< 45	< 45	< 45	< 45	< 45
24 V DC power supply for the Control Unit	A	1.0	1.0	1.0	1.0	1.0
Rated input current ¹⁾ with/without line reactor	A	1.3/1.7	1.7/2.2	2.2/2.6	3.1/3.9	4.1/4.8
Resistance value of the external braking resistor	Ohm	≥ 390	≥ 390	≥ 390	≥ 390	≥ 390
Max. cable length to braking resistor	m (ft)	15 (49)	15 (49)	15 (49)	15 (49)	15 (49)
Line supply connection L, N		Screw-type terminals for cable cross section 1.0 mm ² to 2.5 mm ²	Screw-type terminals for cable cross section 1.0 mm ² to 2.5 mm ²	Screw-type terminals for cable cross section 1.0 mm ² to 2.5 mm ²	Screw-type terminals for cable cross section 1.0 mm ² to 2.5 mm ²	Screw-type terminals for cable cross section 1.0 mm ² to 2.5 mm ²
Motor connection U2, V2, W2		Screw-type terminals for cable cross section 1.0 mm ² to 2.5 mm ²	Screw-type terminals for cable cross section 1.0 mm ² to 2.5 mm ²	Screw-type terminals for cable cross section 1.0 mm ² to 2.5 mm ²	Screw-type terminals for cable cross section 1.0 mm ² to 2.5 mm ²	Screw-type terminals for cable cross section 1.0 mm ² to 2.5 mm ²
DC link connection, connection for braking resistor DCP/R1, DCN, R2		Screw-type terminals for cable cross section 1.0 mm ² to 2.5 mm ²	Screw-type terminals for cable cross section 1.0 mm ² to 2.5 mm ²	Screw-type terminals for cable cross section 1.0 mm ² to 2.5 mm ²	Screw-type terminals for cable cross section 1.0 mm ² to 2.5 mm ²	Screw-type terminals for cable cross section 1.0 mm ² to 2.5 mm ²
PE connection		On housing with M4 screw	On housing with M4 screw	On housing with M4 screw	On housing with M4 screw	On housing with M4 screw
Max. motor cable length ²⁾	m (ft)	50 (164) shielded 75 (246) unshielded	50 (164) shielded 75 (246) unshielded	50 (164) shielded 75 (246) unshielded	50 (164) shielded 75 (246) unshielded	50 (164) shielded 75 (246) unshielded
Degree of protection		IP20	IP20	IP20	IP20	IP20
Width	mm (inch)	73 (2.87)	73 (2.87)	73 (2.87)	73 (2.87)	73 (2.87)
Height	mm (inch)	173 (6.81)	173 (6.81)	173 (6.81)	173 (6.81)	173 (6.81)
Depth						
• PM340 Power Module	mm (inch)	145 (5.7)	145 (5.7)	145 (5.7)	145 (5.7)	145 (5.7)
• PM340 with CU310	mm (inch)	234.6 (9.24)	234.6 (9.24)	234.6 (9.24)	234.6 (9.24)	234.6 (9.24)
• PM340 with CUA31	mm (inch)	175.3 (6.9)	175.3 (6.9)	175.3 (6.9)	175.3 (6.9)	175.3 (6.9)
Size		FSA	FSA	FSA	FSA	FSA
Weight, approx.	kg (lb)	1.2 (3)	1.2 (3)	1.2 (3)	1.2 (3)	1.2 (3)

¹⁾ The input current depends on the motor load and line impedance. The input currents apply for rated power loading (based on I_{rated}) for a line impedance corresponding to $u_k = 1\%$.

²⁾ Max. motor cable length 25 m (82 ft) (shielded) for PM340 Power Modules with integrated line filter to maintain the limit values of EN 61800-3 Category C2.

³⁾ Nominal HP based on Asynchronous motors (induction motors) and 460 V AC. For specific sizing select drive based on motor nameplate current and overload.

Technical data (continued)

Line voltage 380 V to 480 V 3 AC		PM340 Power Modules in blocksize format					
		6SL3210-1SE16-0...	6SL3210-1SE17-7...	6SL3210-1SE21-0...	6SL3210-1SE21-8...	6SL3210-1SE22-5...	6SL3210-1SE23-2...
Rated output current I_{rated}	A	5.9	7.7	10.2	18	25	32
Base load current I_H	A	5.2	6.8	9.1	14	21	27
Output current for S6 duty (40%) I_{S6}	A	6.4	8.3	10.8	19.6	27.8	37.1
Max. output current I_{max}	A	11.8	15.4	20.4	26.4	38	52
Rated power based on I_{rated}	kW (HP) ³⁾	2.2 (3)	3 (5)	4 (5)	7.5 (10)	11 (15)	15 (20)
Rated power based on I_H	kW (HP) ³⁾	2.2 (3)	3 (4)	4 (5)	5.5 (10)	7.5 (15)	11 (20)
Rated pulse frequency	kHz	4	4	4	4	4	4
Efficiency η		0.96	0.97	0.97	0.98	0.98	0.98
Power loss	kW	0.14	0.16	0.18	0.24	0.30	0.40
Cooling air requirement	m ³ /s (ft ³ /s)	0.009 (0.03)	0.009 (0.03)	0.009 (0.03)	0.038 (0.12)	0.038 (0.12)	0.038 (0.12)
Sound pressure level	dB(A)	< 50	< 50	< 50	< 60	< 60	< 60
24 V DC power supply for the Control Unit	A	1.0	1.0	1.0	1.0	1.0	1.0
Rated input current ¹⁾ with/without line reactor	A	5.6/6.7	7.5/8.9	9.8/12.4	17.1/23.1	24.6/32.6	33/39
Resistance value of the external braking resistor	Ohm	≥ 160	≥ 160	≥ 160	≥ 56	≥ 56	≥ 56
Max. cable length to braking resistor	m (ft)	15 (49)	15 (49)	15 (49)	15 (49)	15 (49)	15 (49)
Line supply connection L, N		Screw-type terminals for cable cross section 1.0 mm ² to 6 mm ²	Screw-type terminals for cable cross section 1.0 mm ² to 6 mm ²	Screw-type terminals for cable cross section 1.0 mm ² to 6 mm ²	Screw-type terminals for cable cross section 2,5 mm ² to 10 mm ²	Screw-type terminals for cable cross section 2,5 mm ² to 10 mm ²	Screw-type terminals for cable cross section 2,5 mm ² to 10 mm ²
Motor connection U2, V2, W2		Screw-type terminals for cable cross section 1.0 mm ² to 6 mm ²	Screw-type terminals for cable cross section 1.0 mm ² to 6 mm ²	Screw-type terminals for cable cross section 1.0 mm ² to 6 mm ²	Screw-type terminals for cable cross section 2,5 mm ² to 10 mm ²	Screw-type terminals for cable cross section 2,5 mm ² to 10 mm ²	Screw-type terminals for cable cross section 2,5 mm ² to 10 mm ²
DC link connection, connection for braking resistor DCP/R1, DCN, R2		Screw-type terminals for cable cross section 1.0 mm ² to 6 mm ²	Screw-type terminals for cable cross section 1.0 mm ² to 6 mm ²	Screw-type terminals for cable cross section 1.0 mm ² to 6 mm ²	Screw-type terminals for cable cross section 2,5 mm ² to 10 mm ²	Screw-type terminals for cable cross section 2,5 mm ² to 10 mm ²	Screw-type terminals for cable cross section 2,5 mm ² to 10 mm ²
PE connection		On housing with M5 screw	On housing with M5 screw	On housing with M5 screw	On housing with M5 screw	On housing with M5 screw	On housing with M5 screw
Max. motor cable length ²⁾	m (ft)	50 (164) shielded 75 (246) unshielded	50 (164) shielded 75 (246) unshielded	50 (164) shielded 75 (246) unshielded	50 (164) shielded 75 (246) unshielded	50 (164) shielded 75 (246) unshielded	50 (164) shielded 75 (246) unshielded
Degree of protection		IP20	IP20	IP20	IP20	IP20	IP20
Width	mm (inch)	153 (6.02)	153 (6.02)	153 (6.02)	188.4 (7.42)	188.4 (7.42)	188.4 (7.42)
Height	mm (inch)	270 (10.63)	270 (10.63)	270 (10.63)	333.4 (13.13)	333.4 (13.13)	333.4 (13.13)
Depth							
• PM340 Power Module	mm (inch)	165 (6.5)	165 (6.5)	165 (6.5)	185 (7.28)	185 (7.28)	185 (7.28)
• PM340 with CU310	mm (inch)	254.6 (10.02)	254.6 (10.02)	254.6 (10.02)	274.6 (10.81)	274.6 (10.81)	274.6 (10.81)
• PM340 with CUA31	mm (inch)	195.3 (7.69)	195.3 (7.69)	195.3 (7.69)	215.3 (8.48)	215.3 (8.48)	215.3 (8.48)
Size		FSB	FSB	FSB	FSC	FSC	FSC
Weight, approx.	kg (lb)	4.0 (9)	4.0 (9)	4.0 (9)	6.5 (14)	6.5 (14)	6.5 (14)

¹⁾ The input current depends on the motor load and line impedance. The input currents apply for rated power loading (based on I_{rated}) for a line impedance corresponding to $u_k = 1\%$.

²⁾ Max. motor cable length 25 m (82 ft) (shielded) for PM340 Power Modules with integrated line filter to maintain the limit values of EN 61800-3 Category C2.

³⁾ Nominal HP based on Asynchronous motors (induction motors) and 460 V AC. For specific sizing select drive based on motor nameplate current and overload.

SINAMICS S120

Power Modules and line-side components

Power Modules in blocksize format

Technical data (continued)

Line voltage 380 V to 480 V 3 AC		PM340 Power Modules in blocksize format					
		6SL3210-1SE23-8...	6SL3210-1SE24-5...	6SL3210-1SE26-0...	6SL3210-1SE27-5...	6SL3210-1SE31-0...	
Rated output current I_{rated}	A	38	45	60	75	90	
Base load current I_H	A	33	40	48	65	80	
Output current for S6 duty (40%) I_{S6}	A	49	58	78	98	117	
Max. output current I_{max}	A	64	76	90	124	150	
Rated power based on I_{rated}	kW (HP) ³⁾	18.5 (25)	22 (30)	30 (40)	37 (50)	45 (60)	
Rated power based on I_H	kW (HP) ³⁾	15 (20)	18.5 (30)	22 (30)	30 (50)	37 (60)	
Rated pulse frequency	kHz	4	4	4	4	4	
Efficiency η		0.98	0.98	0.98	0.98	0.98	
Power loss	kW	0.38	0.51	0.69	0.99	1.21	
Cooling air requirement	m ³ /s (ft ³ /s)	0.022 (0.07)	0.022 (0.07)	0.039 (0.13)	0.022 (0.07)	0.039 (0.13)	
Sound pressure level	dB(A)	< 60	< 60	< 61	< 60	62	
24 V DC power supply for the Control Unit	A	1.0	1.0	1.0	1.0	1.0	
Rated input current ¹⁾ with/without line reactor	A	40/46	47/53	63/72	78/88	94/105	
Resistance value of the external braking resistor	Ohm	≥ 27	≥ 27	≥ 27	≥ 15	≥ 15	
Max. cable length to braking resistor	m (ft)	15 (49)	15 (49)	15 (49)	15 (49)	15 (49)	
Line supply connection L, N		Stud M6, cable cross section that can be connected 10 mm ² to 35 mm ²	Stud M6, cable cross section that can be connected 10 mm ² to 35 mm ²	Stud M6, cable cross section that can be connected 10 mm ² to 35 mm ²	Stud M6, cable cross section that can be connected 10 mm ² to 35 mm ²	Stud M6, cable cross section that can be connected 10 mm ² to 35 mm ²	
Motor connection U2, V2, W2		Stud M6, cable cross section that can be connected 10 mm ² to 35 mm ²	Stud M6, cable cross section that can be connected 10 mm ² to 35 mm ²	Stud M6, cable cross section that can be connected 10 mm ² to 35 mm ²	Stud M6, cable cross section that can be connected 10 mm ² to 35 mm ²	Stud M6, cable cross section that can be connected 10 mm ² to 35 mm ²	
DC link connection, connection for braking resistor DCP/R1, DCN, R2		Stud M6, cable cross section that can be connected 10 mm ² to 35 mm ²	Stud M6, cable cross section that can be connected 10 mm ² to 35 mm ²	Stud M6, cable cross section that can be connected 10 mm ² to 35 mm ²	Stud M6, cable cross section that can be connected 10 mm ² to 35 mm ²	Stud M6, cable cross section that can be connected 10 mm ² to 35 mm ²	
PE connection		On housing with M6 screw	On housing with M6 screw	On housing with M6 screw	On housing with M6 screw	On housing with M6 screw	
Max. motor cable length ²⁾	m (ft)	70 (230) shielded 100 (328) unshielded	70 (230) shielded 100 (328) unshielded	70 (230) shielded 100 (328) unshielded	70 (230) shielded 100 (328) unshielded	70 (230) shielded 100 (328) unshielded	
Degree of protection		IP20	IP20	IP20	IP20	IP20	
Width	mm (inch)	275 (10.83)	275 (10.83)	275 (10.83)	275 (10.83)	275 (10.83)	
Height PM340 without/with integrated filter	mm (inch)	418.3/511 (16.47/20.12)	418.3/511 (16.47/20.12)	418.3/511 (16.47/20.12)	498.3/633 (19.62/24.92)	498.3/633 (19.62/24.92)	
Depth							
• PM340 Power Module	mm (inch)	203.5 (8.01)	203.5 (8.01)	203.5 (8.01)	203.5 (8.01)	203.5 (8.01)	
• PM340 with CU310	mm (inch)	293.1 (11.54)	293.1 (11.54)	293.1 (11.54)	293.1 (11.54)	293.1 (11.54)	
• PM340 with CUA31	mm (inch)	233.8 (9.2)	233.8 (9.2)	233.8 (9.2)	233.8 (9.2)	233.8 (9.2)	
Size		FSD	FSD	FSD	FSE	FSE	
Weight, approx. PM340 without/with integrated filter	kg (lb)	15.9/19.3 (35/43)	15.9/19.3 (35/43)	15.9/19.3 (35/43)	19.8/27.1 (44/60)	19.8/27.1 (44/60)	

¹⁾ The input current depends on the motor load and line impedance. The input currents apply for rated power loading (based on I_{rated}) for a line impedance corresponding to $u_k = 1\%$.

²⁾ Max. motor cable length 25 m (82 ft) (shielded) for PM340 Power Modules with integrated line filter to maintain the limit values of EN 61800-3 Category C2.

³⁾ Nominal HP based on Asynchronous motors (induction motors) and 460 V AC. For specific sizing select drive based on motor nameplate current and overload.

Technical data (continued)

Line voltage 380 V to 480 V 3 AC		PM340 Power Modules in blocksize format		
		6SL3210-1SE31-1...	6SL3210-1SE31-5...	6SL3210-1SE31-8...
Rated output current I_{rated}	A	110	145	178
Base load current I_H	A	95	115	155
Output current for S6 duty (40%) I_{S6}	A	143	188	231
Max. output current I_{max}	A	180	220	290
Rated power based on I_{rated}	kW (HP) ³⁾	55 (75)	75 (100)	90 (125)
Rated power based on I_H	kW (HP) ³⁾	45 (60)	55 (75)	75 (100)
Rated pulse frequency	kHz	4	4	4
Efficiency η		0.98	0.98	0.98
Power loss	kW	1.42	1.93	2.31
Cooling air requirement	m ³ /s (ft ³ /s)	0.094 (0.31)	0.094 (0.31)	0.117 (0.38)
Sound pressure level	dB(A)	< 60	< 60	65
24 V DC power supply for the Control Unit	A	1.0	1.0	1.0
Rated input current ¹⁾ with/without line reactor	A	115/129	151/168	186/204
Resistance value of the external braking resistor	Ohm	≥ 8.2	≥ 8.2	≥ 8.2
Max. cable length to braking resistor	m (ft)	15 (49)	15 (49)	15 (49)
Line supply connection U1/L1, V1/L2, W1/L3		Stud M8, max. cable cross section that can be connected 120 mm ² or 2 x 50 mm ²	Stud M8, max. cable cross section that can be connected 120 mm ² or 2 x 50 mm ²	Stud M8, max. cable cross section that can be connected 120 mm ² or 2 x 50 mm ²
Motor connection U2, V2, W2		Stud M8, max. cable cross section that can be connected 120 mm ² or 2 x 50 mm ²	Stud M8, max. cable cross section that can be connected 120 mm ² or 2 x 50 mm ²	Stud M8, max. cable cross section that can be connected 120 mm ² or 2 x 50 mm ²
DC link connection, connection for braking resistor DCP/R1, DCN, R2		Stud M8, max. cable cross section that can be connected 120 mm ² or 2 x 50 mm ²	Stud M8, max. cable cross section that can be connected 120 mm ² or 2 x 50 mm ²	Stud M8, max. cable cross section that can be connected 120 mm ² or 2 x 50 mm ²
PE connection		On housing with M8 screw	On housing with M8 screw	On housing with M8 screw
Max. motor cable length ²⁾	m (ft)	70 (230) shielded 100 (328) unshielded	70 (230) shielded 100 (328) unshielded	70 (230) shielded 100 (328) unshielded
Degree of protection		IP20	IP20	IP20
Width	mm (inch)	350 (13.78)	350 (13.78)	350 (13.78)
Height PM340 without/with integrated filter	mm (inch)	634/934 (24.96/36.77)	634/934 (24.96/36.77)	634/934 (24.96/36.77)
Depth				
• PM340 Power Module	mm (inch)	315.5 (12.42)	315.5 (12.42)	315.5 (12.42)
• PM340 with CU310	mm (inch)	405.1 (15.95)	405.1 (15.95)	405.1 (15.95)
• PM340 with CUA31	mm (inch)	345.8 (13.61)	345.8 (13.61)	345.8 (13.61)
Size		FSF	FSF	FSF
Weight, approx. PM340 without/with integrated filter	kg (lb)	50.7/66.7 (112/147)	50.7/66.7 (112/147)	50.7/66.7 (112/147)

¹⁾ The input current depends on the motor load and line impedance. The input currents apply for rated power loading (based on I_{rated}) for a line impedance corresponding to $u_k = 1\%$.

²⁾ Max. motor cable length 25 m (82 ft) (shielded) for PM340 Power Modules with integrated line filter to maintain the limit values of EN 61800-3 Category C2.

³⁾ Nominal HP based on Asynchronous motors (induction motors) and 460 V AC. For specific sizing select drive based on motor nameplate current and overload.

SINAMICS S120

Power Modules and line-side components

Power Modules in blocksize format

Selection and ordering data

Rated output current	Rated power	Size	PM340 Power Module in blocksize format without line filter	PM340 Power Module in blocksize format with integrated line filter
A	kW (HP) ¹⁾		Order No.	Order No.
Line voltage 200 V to 240 V 1 AC				
0.9	0.12 (0.2)	FSA	6SL3210-1SB11-0UA0	6SL3210-1SB11-0AA0
2.3	0.37 (0.5)	FSA	6SL3210-1SB12-3UA0	6SL3210-1SB12-3AA0
3.9	0.75 (0.75)	FSA	6SL3210-1SB14-0UA0	6SL3210-1SB14-0AA0
Line voltage 380 V to 480 V 3 AC				
1.3	0.37 (0.5)	FSA	6SL3210-1SE11-3UA0	–
1.7	0.55 (0.75)	FSA	6SL3210-1SE11-7UA0	–
2.2	0.75 (1)	FSA	6SL3210-1SE12-2UA0	–
3.1	1.1 (1.5)	FSA	6SL3210-1SE13-1UA0	–
4.1	1.5 (2)	FSA	6SL3210-1SE14-1UA0	–
5.9	2.2 (3)	FSB	6SL3210-1SE16-0UA0	6SL3210-1SE16-0AA0
7.7	3 (5)	FSB	6SL3210-1SE17-7UA0	6SL3210-1SE17-7AA0
10.2	4 (5)	FSB	6SL3210-1SE21-0UA0	6SL3210-1SE21-0AA0
18	7.5 (10)	FSC	6SL3210-1SE21-8UA0	6SL3210-1SE21-8AA0
25	11 (15)	FSC	6SL3210-1SE22-5UA0	6SL3210-1SE22-5AA0
32	15 (20)	FSC	6SL3210-1SE23-2UA0	6SL3210-1SE23-2AA0
38	18.5 (25)	FCD	6SL3210-1SE23-8UA0	6SL3210-1SE23-8AA0
45	22 (30)	FCD	6SL3210-1SE24-5UA0	6SL3210-1SE24-5AA0
60	30 (40)	FCD	6SL3210-1SE26-0UA0	6SL3210-1SE26-0AA0
75	37 (50)	FSE	6SL3210-1SE27-5UA0	6SL3210-1SE27-5AA0
90	45 (60)	FSE	6SL3210-1SE31-0UA0	6SL3210-1SE31-0AA0
110	55 (75)	FSF	6SL3210-1SE31-1UA0	6SL3210-1SE31-1AA0
145	75 (100)	FSF	6SL3210-1SE31-5UA0	6SL3210-1SE31-5AA0
178	90 (125)	FSF	6SL3210-1SE31-8UA0	6SL3210-1SE31-8AA0

Accessories

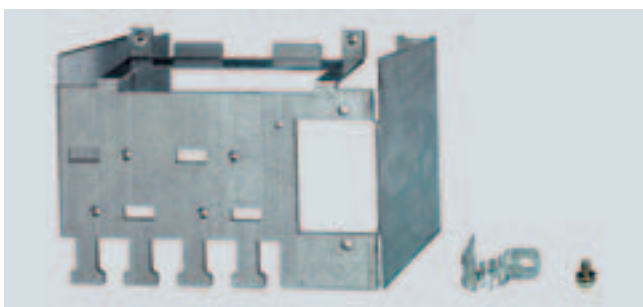

Example of shield connection kit for PM340 frame size FSB

Description	Order No.
Shield connection kit for PM340	
• Frame size FSA	6SL3262-1AA00-0BA0
• Frame size FSB	6SL3262-1AB00-0DA0
• Frame size FSC	6SL3262-1AC00-0DA0
• Frame sizes FSD and FSE	6SL3262-1AD00-0DA0
• Frame size FSF	6SL3262-1AF00-0DA0

¹⁾ Nominal HP based on Asynchronous motors (induction motors).
See technical data for specific sizing.

Characteristics

Overload capability

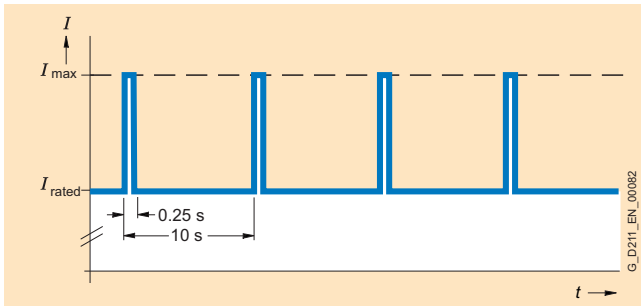

Load cycle with previous load

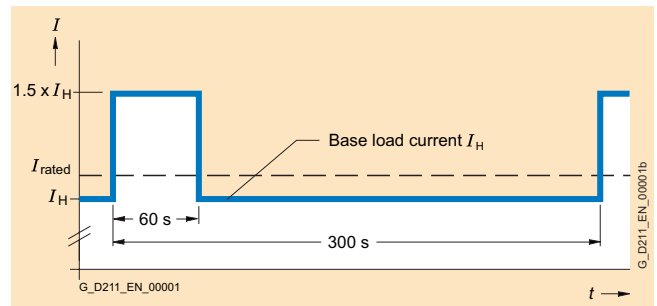

Load cycle with 60 s overload with a load cycle period of 300 s

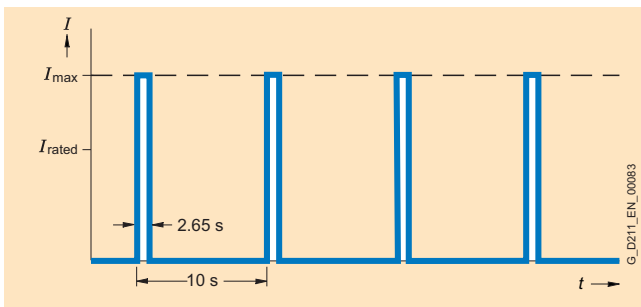

Load cycle without previous load

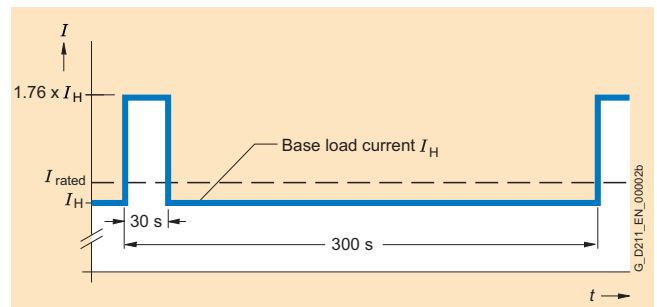

Load cycle with 30 s overload with a load cycle period of 300 s

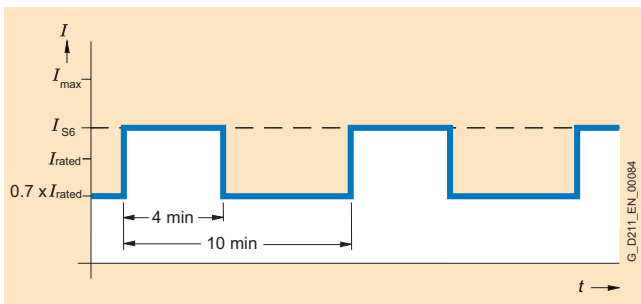

S6 load cycle with previous load with a load cycle period of 600 s

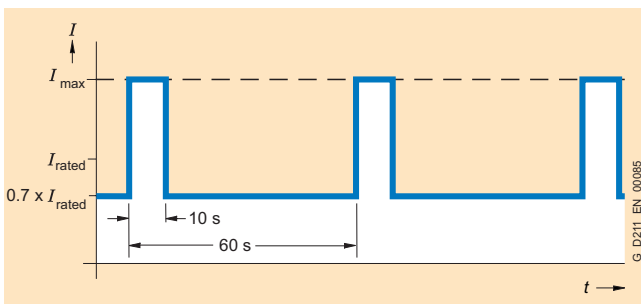

S6 load cycle with previous load with a load cycle period of 60 s

SINAMICS S120

Power Modules and line-side components

Power Modules in blocksize format

Characteristics (continued)

Derating characteristics

- Frame sizes FSA to FSE

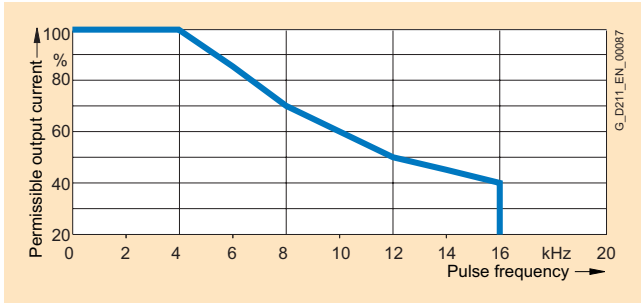

Output current dependent on pulse frequency

- Frame sizes FSF

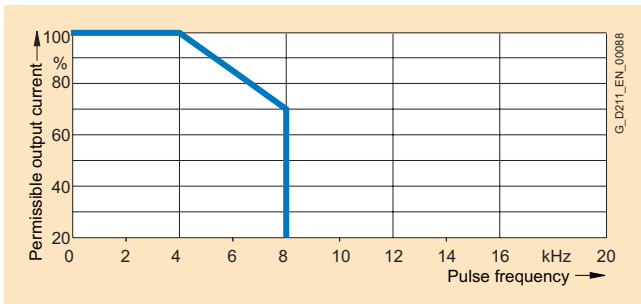

Output current dependent on pulse frequency

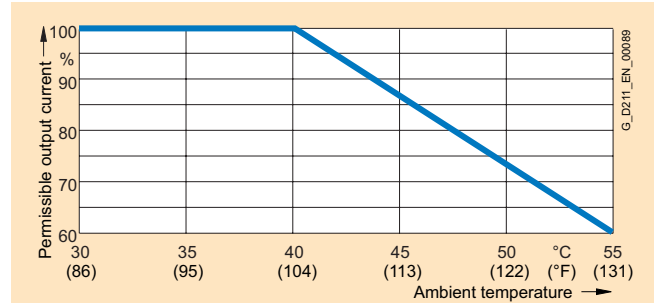

Output current dependent on ambient temperature

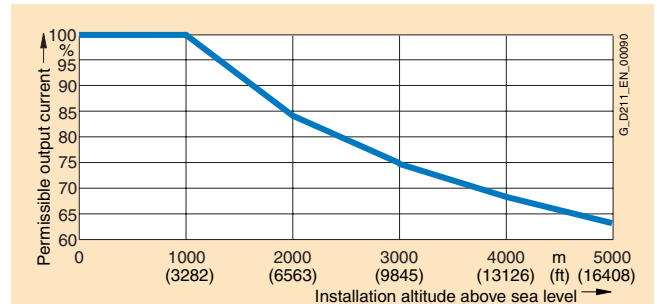

Output current dependent on installation altitude

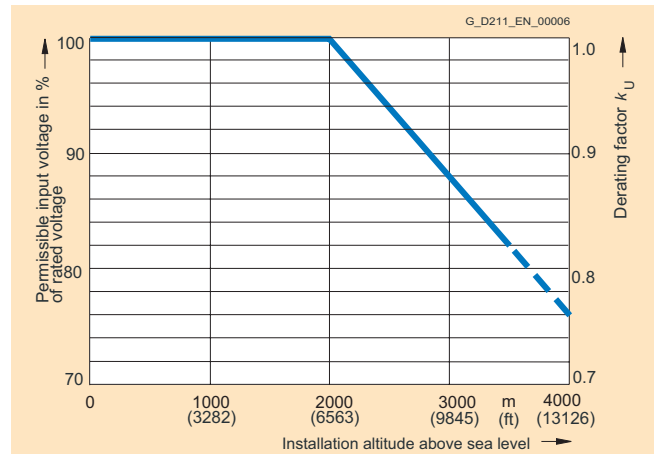

Voltage derating dependent on installation altitude

Overview



Line reactor for PM340 Power Modules frame sizes FSA to FSE



Line reactor for PM340 Power Modules frame size FSF

Line reactors limit the low-frequency harmonic effects and reduce the load on the rectifiers of the Power Modules. A line reactor is not required where the effective supply impedance equals $u_k \geq 1\%$. For further information see System Description.

Integration

The line reactors for PM340 Power Modules of frame sizes FSA to FSE are designed as base components. The line reactor is attached to the mounting surface and the Power Module is mounted directly on the line reactor. The cables to the Power Module are already connected at the line reactor.

The line reactor is connected to the line supply through terminals.



PM340 Power Module frame size FSB with base line reactor and shield connection kit

SINAMICS S120

Power Modules and line-side components

Power Modules in blocksize format Line reactors

Technical data

Line voltage 200 V to 240 V 1 AC		Line reactor 6SE6400-3CC00-4AB3		6SE6400-3CC01-0AB3	
Rated current	A	3.4		8.1	
Power loss, approx. at 50 Hz/60 Hz	W	12.5/15		11.5/14.5	
Power connection U1, V1, W1		6 mm ² screw-type terminals		6 mm ² screw-type terminals	
Load connection		Cable 3 x AWG16 (1.5 mm ²) Length approx. 0.38 m (1.25 ft)		Cable 3 x AWG16 (1.5 mm ²) Length approx. 0.38 m (1.25 ft)	
PE connection		M5 bolt		M5 bolt	
Degree of protection		IP20		IP20	
Width	mm (inch)	75.5 (2.97)		75.5 (2.97)	
Height	mm (inch)	201 (7.91)		201 (7.91)	
Depth	mm (inch)	50 (1.97)		50 (1.97)	
Weight, approx.	kg (lb)	1.3 (3)		1.3 (3)	
Suitable for PM340 Power Module	Type	6SL3210-1SB11-0... 6SL3210-1SB12-3...		6SL3210-1SB14-0...	

Line voltage 380 V to 480 V 3 AC		Line reactor 6SE6400-3CC00-2AD3		6SE6400-3CC00-4AD3		6SE6400-3CC00-6AD3		6SL3203-0CD21-0AA0		6SL3203-0CD21-4AA0		6SL3203-0CD22-2AA0	
Rated current	A	1.9		3.5		4.8		9		11.6		25	
Power loss at 50 Hz/60 Hz	W	6/7		12.5/15		7.5/9		9/11		27/32		98/118	
Power connection U1, V1, W1		6 mm ² screw-type terminals		6 mm ² screw-type terminals		6 mm ² screw-type terminals		6 mm ² screw-type terminals		6 mm ² screw-type terminals		6 mm ² screw-type terminals	
Load connection		Cable 4 x AGW 16 (1.5 mm ²) length approx. 0.38 m (1.25 ft)		Cable 4 x AGW 16 (1.5 mm ²) length approx. 0.38 m (1.25 ft)		Cable 4 x AGW 16 (1.5 mm ²) length approx. 0.38 m (1.25 ft)		Cable 4 x AGW 16 (1.5 mm ²) length approx. 0.46 m (1.51 ft)		Cable 4 x AGW 16 (1.5 mm ²) length approx. 0.46 m (1.51 ft)		Cable 4 x AGW 10 (2.5 mm ²) length approx. 0.49 m (1.61 ft)	
PE connection		On housing with M5 bolt		On housing with M5 bolt		On housing with M5 bolt		On housing with M5 bolt		On housing with M5 bolt		On housing with M5 bolt	
Degree of protection ¹⁾		IP20		IP20		IP20		IP20		IP20		IP20	
Width	mm (inch)	75.5 (2.97)		75.5 (2.97)		75.5 (2.97)		153 (6.02)		153 (6.02)		190 (7.48)	
Height	mm (inch)	201 (7.91)		201 (7.91)		201 (7.91)		290 (11.42)		290 (11.42)		370 (14.57)	
Depth	mm (inch)	50 (1.97)		50 (1.97)		50 (1.97)		70 (2.76)		70 (2.76)		50 (1.97)	
Weight, approx.	kg (lb)	1.2 (3)		1.3 (3)		1.3 (3)		3.4 (7)		3.4 (7)		6.3 (14)	
Suitable for PM340 Power Module	Type	6SL3210-1SE11-3... 6SL3210-1SE11-7...		6SL3210-1SE12-2... 6SL3210-1SE13-1...		6SL3210-1SE14-1...		6SL3210-1SE16-0... 6SL3210-1SE17-7...		6SL3210-1SE21-0...		6SL3210-1SE21-8... 6SL3210-1SE22-5...	

¹⁾ With correctly connected load connection cable.

Technical data (continued)

Line voltage 380 V to 480 V 3 AC		Line reactor					
		6SL3203- 0CD23-5AA0	6SL3203- 0CJ24-5AA0	6SL3203- 0CD25-3AA0	6SL3203- 0CJ28-6AA0	6SE6400- 3CC11-2FD0	6SE6400- 3CC11-7FD0
Rated current	A	31.3	54	71	105	178	225
Power loss at 50 Hz/60 Hz	W	37/44	90/115	90/115	170/215	280/360	280/360
Power connection U1, V1, W1		6 mm ² screw- type terminals	16 mm ² screw- type terminals	16 mm ² screw- type terminals	50 mm ² screw- type terminals	Flat connector for M10 cable lug	Flat connector for M10 cable lug
Load connection		Cable 4 x AWG10 (2.5 mm ²) Length approx. 0.49 m (1.61 ft)	Cable 4 x 16 mm ² length approx. 0.7 m (2.3 ft)	Cable 4 x 16 mm ² length approx. 0.7 m (2.3 ft)	Cable 4 x 35 mm ² length approx. 0.7 m (2.3 ft)	Flat connector for M10 cable lug	Flat connector for M10 cable lug
PE connection		On housing with M5 bolt	On housing with M8 screw	On housing with M8 screw	On housing with M8 screw	On housing with M8 bolt	On housing with M8 bolt
Degree of protection ¹⁾		IP20	IP20	IP20	IP20	IP00	IP00
Width	mm (inch)	190 (7.48)	275 (10.83)	275 (10.83)	275 (10.83)	240 (9.45)	240 (9.45)
Height	mm (inch)	370 (14.57)	455 (17.91)	455 (17.91)	577 (22.72)	228 (8.98)	228 (8.98)
Depth	mm (inch)	50 (1.97)	83.5 (3.29)	83.5 (3.29)	93.5 (3.68)	141 (5.55)	141 (5.55)
Weight, approx.	kg (lb)	6.4 (14)	13 (29)	13 (29)	19 (42)	25 (55)	25 (55)
Suitable for PM340 Power Module	Type	6SL3210- 1SE23-2...	6SL3210- 1SE23-8... 6SL3210- 1SE24-5...	6SL3210- 1SE26-0...	6SL3210- 1SE27-5... 6SL3210- 1SE31-0...	6SL3210- 1SE31-1... 6SL3210- 1SE31-5...	6SL3210- 1SE31-8...

Selection and ordering data

Rated output current A	Rated power kW (HP)	Suitable for PM340 Power Module		Line reactor
		Type	Size	Order No.
Line voltage 200 V to 240 V 1 AC				
0.9	0.12 (0.2)	6SL3210-1SB11-0...	FSA	6SE6400-3CC00-4AB3
2.3	0.37 (0.5)	6SL3210-1SB12-3...	FSA	6SE6400-3CC00-4AB3
3.9	0.75 (0.75)	6SL3210-1SB14-0...	FSA	6SE6400-3CC01-0AB3
Line voltage 380 V to 480 V 3 AC				
1.3	0.37 (0.5)	6SL3210-1SE11-3UA0	FSA	6SE6400-3CC00-2AD3
1.7	0.55 (0.75)	6SL3210-1SE11-7UA0	FSA	6SE6400-3CC00-2AD3
2.2	0.75 (1)	6SL3210-1SE12-2UA0	FSA	6SE6400-3CC00-4AD3
3.1	1.1 (1.5)	6SL3210-1SE13-1UA0	FSA	6SE6400-3CC00-4AD3
4.1	1.5 (2)	6SL3210-1SE14-1UA0	FSA	6SE6400-3CC00-6AD3
5.9	2.2 (3)	6SL3210-1SE16-0...	FSB	6SL3203-0CD21-0AA0
7.7	3 (5)	6SL3210-1SE17-7...	FSB	6SL3203-0CD21-0AA0
10	4 (5)	6SL3210-1SE21-0...	FSB	6SL3203-0CD21-4AA0
18	7.5 (10)	6SL3210-1SE21-8...	FSC	6SL3203-0CD22-2AA0
25	11 (15)	6SL3210-1SE22-5...	FSC	6SL3203-0CD22-2AA0
32	15 (20)	6SL3210-1SE23-2...	FSC	6SL3203-0CD23-5AA0
38	18.5 (25)	6SL3210-1SE23-8...	FCD	6SL3203-0CJ24-5AA0
45	22 (30)	6SL3210-1SE24-5...	FCD	6SL3203-0CJ24-5AA0
60	30 (40)	6SL3210-1SE26-0...	FCD	6SL3203-0CD25-3AA0
75	37 (50)	6SL3210-1SE27-5...	FSE	6SL3203-0CJ28-6AA0
90	45 (60)	6SL3210-1SE31-0...	FSE	6SL3203-0CJ28-6AA0
110	55 (75)	6SL3210-1SE31-1...	FSF	6SE6400-3CC11-2FD0
145	75 (100)	6SL3210-1SE31-5...	FSF	6SE6400-3CC11-2FD0
178	90 (125)	6SL3210-1SE31-8...	FSF	6SE6400-3CC11-7FD0

¹⁾ With correctly connected load connection cable.

SINAMICS S120

Power Modules and line-side components

Power Modules in blocksize format Line filters

Overview



In plants with strict EMC requirements, the line filter for frame size FSA restricts the conducted interference emanating from the PM340 Power Module to the limit values of Class A1 as defined in EN 55011 and Category C2 as defined in EN 61800-3. The line filter is suited only for direct connection to TN (grounded) systems.

Note: The line filter is designed only for PM340 Power Modules of frame size FSA and a line voltage of 380 V to 480 V 3 AC. All other PM340 Power Modules are available with integrated line filter.

Integration

Line filter, line reactor and Power Module can be mounted in front of one another.

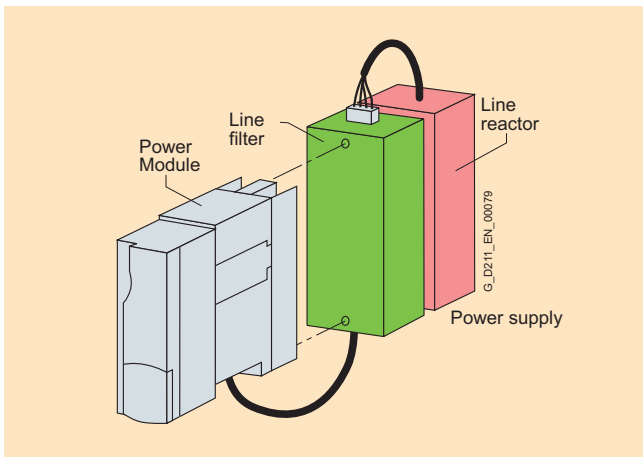

Technical data

Line voltage 380 V to 480 V 3 AC	Line filter
Rated current	6 A
Power loss	< 5 W
Line supply connection L1, L2, L3	2.5 mm ² screw-type terminals
PE connection	On housing with M4 stud
Load connection U, V, W	Shielded cable 3 x 2.5 mm ² 0.4 m (1.3 ft) long
Degree of protection	IP20 (with correctly connected load connection cable)
Weight, approx.	0.5 kg (1 lb)
Width	73.5 mm (2.89 in)
Height	200 mm (7.87 in)
Depth	44 mm (1.73 in)
Suitable for PM340 Power Module Type	6SL3210-1SE11-... 6SL3210-1SE12-... 6SL3210-1SE13-... 6SL3210-1SE14-...

Selection and ordering data

Suitable for PM340 Power Module Frame size FSA	Line filter
Type	Order No.
Line voltage 380 V to 480 V 3 AC	
6SL3210-1SE11-...	6SE6400-2FA00-6AD0
6SL3210-1SE12-...	
6SL3210-1SE13-...	
6SL3210-1SE14-...	

SINAMICS S120

Power Modules and line-side components

Power Modules in blocksize format Recommended line-side components

Overview

Assignment of line-side power components to Power Modules in blocksize format

Suitable line-side power components are assigned depending on the power rating of the Power Modules.

The following tables list recommended components and apply for ambient temperatures up to 40 °C (104 °F).

Further information about the main contactors, switch disconnectors, fuses and circuit-breakers specified in the tables can be found in Catalogs LV1, LV1T and BT BI. ¹⁾

Rated output current	Rated power	Suitable for PM340 Power Module	Main contactor (Insta-contactor)	Miniature circuit breakers	Fuse switch disconnecter	Fuse
A	kW (HP)	Type 6SL3210-...	Type	Order No.	Order No.	Order No.
Line voltage 200 V to 240 V 1 AC						
0.9	0.12 (0.2)	1SB11-0...	5TT57-...	5SY6110-7	3NC1091	3NW6003-1
2.3	0.37 (0.5)	1SB12-3...	5TT57-...	5SY6110-7	3NC1091	3NW6003-1
3.9	0.75 (0.75)	1SB14-0...	5TT57-...	5SY6116-7	3NC1091	3NW6005-1

Rated output current	Rated power	Suitable for PM340 Power Module	Main contactor	Circuit-breaker	Main switch (switch disconnecter)	Fuse switch disconnecter	Switch disconnecter with fuse holders	Low-voltage HRC fuse element
A	kW	Type 6SL3210-...	Type	Order No.	Order No.	Order No.	Order No.	Order No.
Line voltage 380 V to 480 V 3 AC								
1.3	0.37 (0.5)	1SE11-3UA0	3RT1015-...	3RV1021-1CA10	3LD2003-1TP51	3NP4010-0CH01	3KL5030-1EB01	3NA3803
1.7	0.55 (0.75)	1SE11-7UA0	3RT1015-...	3RV1021-1DA10	3LD2003-1TP51	3NP4010-0CH01	3KL5030-1EB01	3NA3803
2.2	0.75 (1)	1SE12-2UA0	3RT1015-...	3RV1021-1FA10	3LD2003-1TP51	3NP4010-0CH01	3KL5030-1EB01	3NA3803
3.1	1.1 (1.5)	1SE13-1UA0	3RT1015-...	3RV1021-1GA10	3LD2003-1TP51	3NP4010-0CH01	3KL5030-1EB01	3NA3803
4.1	1.5 (2)	1SE14-1UA0	3RT1015-...	3RV1021-1HA10	3LD2003-1TP51	3NP4010-0CH01	3KL5030-1EB01	3NA3803
5.9	2.2 (3)	1SE16-0...	3RT1015-...	3RV1021-1KA10	3LD2003-1TP51	3NP4010-0CH01	3KL5030-1EB01	3NA3805
7.7	3 (5)	1SE17-7...	3RT1015-...	3RV1021-4AA10	3LD2003-1TP51	3NP4010-0CH01	3KL5030-1EB01	3NA3805
10	4 (5)	1SE21-0...	3RT1016-...	3RV1021-4BA10	3LD2103-1TP51	3NP4010-0CH01	3KL5030-1EB01	3NA3807
18	7.5 (10)	1SE21-8...	3RT1025-...	3RV1031-4EA10	3LD2203-0TK51	3NP4010-0CH01	3KL5030-1EB01	3NA3807
25	11 (15)	1SE22-5...	3RT1026-...	3RV1031-4FA10	3LD2504-0TK51	3NP4010-0CH01	3KL5030-1EB01	3NA3812
32	15 (20)	1SE23-2...	3RT1034-...	3RV1031-4HA10	3LD2504-0TK51	3NP4010-0CH01	3KL5030-1EB01	3NA3814
38	18.5 (25)	1SE23-8...	3RT1035-...	3RV1042-4JA10	3LD2504-0TK51	3NP4010-0CH01	3KL5030-1EB01	3NA3820
45	22 (30)	1SE24-5...	3RT1036-...	3RV1042-4KA10	3LD2504-0TK51	3NP4010-0CH01	3KL5030-1EB01	3NA3822
60	30 (40)	1SE26-0...	3RT1044-...	3RV1042-4MA10	3LD2704-0TK51	3NP4010-0CH01	3KL5230-1EB01	3NA3824
75	37 (50)	1SE27-5...	3RT1045-...	3VL1712-1DD33-0AA0	3LD2704-0TK51	3NP4010-0CH01	3KL5230-1EB01	3NA3830
90	45 (60)	1SE31-0...	3RT1046-...	3VL1716-1DD33-0AA0	3LD2804-0TK51	3NP4070-0CH01	3KL5230-1EB01	3NA3832
110	55 (75)	1SE31-1...	3RT1054-...	3VL3720-1DC36-0AA0	3KA5330-1EE01	3NP4070-0CH01	3KL5330-1EB01	3NA3836
145	75 (100)	1SE31-5...	3RT1056-...	3VL3725-1DC36-0AA0	3KA5530-1EE01	3NP4270-0CA01	3KL5530-1EB01	3NA3140
178	90 (125)	1SE31-8...	3RT1064-...	3VL4731-1DC36-0AA0	3KA5530-1EE01	3NP4270-0CA01	3KL5530-1EB01	3NA3144

1) Component selections are per IEC standards and not necessarily in accordance with UL or NEC requirements. For NEMA components please see North American Industrial Products Catalog and speedfax Catalog.

SINAMICS S120

Power Modules and line-side components

Power Modules in chassis format

Design



Power Module in chassis format

The Power Modules in chassis format feature the following connections as standard:

- 1 power connection
- 2 DC link connections for options such as Braking Modules
- 3 DRIVE-CLiQ sockets (eliminates the need for CUA31)
- 1 safe standstill input (enable pulses)
- 1 temperature sensor input (KTY84-130 or PTC)
- 1 electronics power supply connection
- 1 motor connection
- 2 PE (protective earth) connections

The CU310 Control Unit can be mounted in Power Modules of chassis format.

The scope of supply of the Power Modules includes:

- 1 DRIVE-CLiQ cable for connection to the CU310 Control Unit
- 1 24 V supply cable for the CU310 Control Unit
- 1 mounting plate for attaching the CU310 Control Unit

Selection and ordering data

Rated output current	Rated power	Power Module in chassis format
A	kW (HP) ¹⁾	Order No.
Line voltage 380 V to 480 V 3 AC		
210	110 (150)	6SL3310-1TE32-1AA0
260	132 (200)	6SL3310-1TE32-6AA0
310	160 (250)	6SL3310-1TE33-1AA0
380	200 (300)	6SL3310-1TE33-8AA0
490	250 (400)	6SL3310-1TE35-0AA0

Warning signs in foreign languages

Warning signs in other languages can be placed on top of the standard warning signs in German or English.

The following signs are supplied with chassis format units: Chinese, Danish, Finnish, French, Greek, Italian, Japanese, Korean, Dutch, Polish, Portuguese, Russian, Swedish, Spanish, Czech and Turkish.

¹⁾ Nominal HP based on Asynchronous motors (induction motors). See technical data for specific sizing.

Integration

The Power Modules in chassis format communicate with the higher-level Control Unit via DRIVE-CLiQ.

The Control Unit in this case could be a CU310 or CU320 or a SIMOTION D Control Unit.

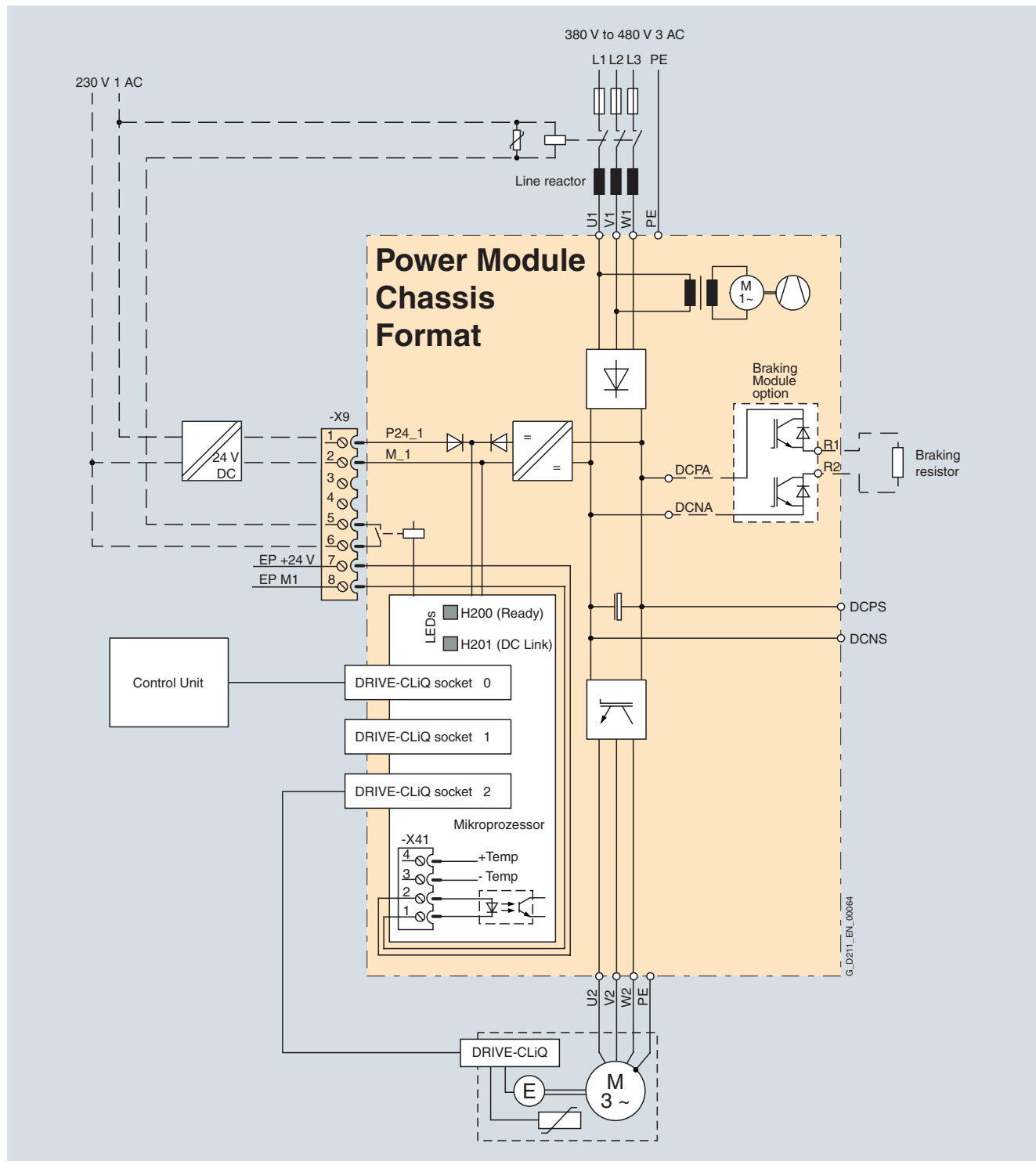

Connection example of a Power Module in chassis format

SINAMICS S120

Power Modules and line-side components

Power Modules in chassis format

Technical data

General technical data

Electrical data	
Line connection voltage (up to 2000 m (6563 ft) above sea level)	380 V to 480 V 3 AC $\pm 10\%$ (– 15% < 1 min)
Power frequency	47 Hz to 63 Hz
Line power factor with a 3 AC line connection voltage and rated output	
• Fundamental Power factor	> 0,96
• Total (λ)	0.75 to 0.93
Overvoltage category	Class III to EN 60664-1
DC link precharging frequency	max. 1x every 300 s
DC link voltage	approx. 1.35 x line voltage
Output frequency	
• Control type Servo	0 Hz to 650 Hz ¹⁾
• Control type Vector	0 Hz to 300 Hz ¹⁾
• Control type V/f	0 Hz to 300 Hz ¹⁾
Electronics power supply	24 V DC – 15%/+ 20%
Main contactor control Terminal strip X9/5-6	240 V AC/ max. 8 A 30 V DC/ max. 1 A
Radio interference suppression	
• Standard	Category C3 to EN 61800-3
• With line filter	Category C2 to EN 61800-3
Ambient conditions	
Type of cooling	Forced air cooling through a built-in fan
Permissible ambient and coolant temperature (air) during operation for line-side components, Line Modules and Motor Modules	0° C to + 40 °C (32 °F to +104 °F) without derating, > 40° C to + 55 °C (> 104 °F to +131 °F) see derating characteristics
Site altitude	Up to 2000 m (6563 ft) above sea level without derating, > 2000 m (6563 ft) to 4000 m (13126 ft) above sea level see derating characteristics
Certificates	
Conformity	CE (low-voltage and EMC Directives)
Approvals	cULus (File No.: E192450)
Certification (in preparation)	Safety Integrity Level 2 (SIL 2) to IEC 61508, control category 3 to EN 954-1 for Safety Integrated – safe standstill (STO = Safe Torque Off)

¹⁾ Note correlation between max. output frequency, pulse frequency and current derating, see System Description.

Technical data (continued)

Line voltage 380 V to 480 V 3 AC		Power Modules in chassis format				
		6SL3310-1TE32-1AA0	6SL3310-1TE32-6AA0	6SL3310-1TE33-1AA0	6SL3310-1TE33-8AA0	6SL3310-1TE35-0AA0
Rated output current I_{rated}	A	210	260	310	380	490
Base load current I_H	A	180	233	277	340	438
Output current for S6 duty (40%) I_{S6}	A	230	285	340	430	540
Max. output current I_{max}	A	307	375	453	555	715
Rated power based on I_{rated}	kW (HP) ³⁾	110 (150)	132 (200)	160 (250)	200 (300)	250 (400)
Rated power based on I_H	kW (HP) ³⁾	90 (150)	110 (150)	132 (200)	160 (250)	200 (350)
Rated pulse frequency	kHz	2	2	2	2	2
Efficiency η		0.986	0.986	0.986	0.986	0.986
Power loss	kW	2.46	3.27	4.0	4.54	5.78
Cooling air requirement	m ³ /s (ft ³ /s)	0.17 (0.56)	0.23 (0.75)	0.36 (1.18)	0.36 (1.18)	0.36 (1.18)
Sound pressure level at 50/60 Hz	dB(A)	66/67	68/72	68/72	68/72	68/72
Rated input current	A	218	270	322	395	510
Power connection U1, V1, W1		Flat connector for M10 cable lug, max. connection cross section 2 x 185 mm ²	Flat connector for M10 cable lug, max. connection cross section 2 x 185 mm ²	Flat connector for M10 cable lug, max. connection cross section 2 x 185 mm ²	Flat connector for M10 cable lug, max. connection cross section 2 x 185 mm ²	Flat connector for M10 cable lug, max. connection cross section 2 x 185 mm ²
DC link connection, DCPA, DCNA (option Braking Module)		Flat connector for M8 cable lug, max. connection cross section 1 x 35 mm ²	Flat connector for M8 cable lug, max. connection cross section 1 x 35 mm ²	Flat connector for M8 cable lug, max. connection cross section 1 x 50 mm ²	Flat connector for M8 cable lug, max. connection cross section 1 x 50 mm ²	Flat connector for M8 cable lug, max. connection cross section 1 x 50 mm ²
DC link connection, DCPS, DCNS (option dv/dt filter)		Flat connector for M8 cable lug, max. connection cross section 1 x 35 mm ²	Flat connector for M8 cable lug, max. connection cross section 1 x 35 mm ²	Flat connector for M8 cable lug, max. connection cross section 1 x 70 mm ²	Flat connector for M8 cable lug, max. connection cross section 1 x 70 mm ²	Flat connector for M8 cable lug, max. connection cross section 1 x 70 mm ²
Motor connection U2, V2, W2		Flat connector for M10 cable lug, max. connection cross section 2 x 185 mm ²	Flat connector for M10 cable lug, max. connection cross section 2 x 185 mm ²	Flat connector for M10 cable lug, max. connection cross section 2 x 185 mm ²	Flat connector for M10 cable lug, max. connection cross section 2 x 185 mm ²	Flat connector for M10 cable lug, max. connection cross section 2 x 185 mm ²
PE connection		Flat connector for M10 cable lug, max. connection cross section 2 x 185 mm ²	Flat connector for M10 cable lug, max. connection cross section 2 x 185 mm ²	Flat connector for M10 cable lug, max. connection cross section 2 x 185 mm ²	Flat connector for M10 cable lug, max. connection cross section 2 x 185 mm ²	Flat connector for M10 cable lug, max. connection cross section 2 x 185 mm ²
Max. motor cable length ¹⁾	m (ft)	300 (984), shielded 450 (1477), unshielded	300 (984), shielded 450 (1477), unshielded	300 (984), shielded 450 (1477), unshielded	300 (984), shielded 450 (1477), unshielded	300 (984), shielded 450 (1477), unshielded
Degree of protection		IP20	IP20	IP20	IP20	IP20
Width	mm (inch)	326 (12.83)	326 (12.83)	326 (12.83)	326 (12.83)	326 (12.83)
Height	mm (inch)	1400 (55.12)	1400 (55.12)	1533 (60.35)	1533 (60.35)	1533 (60.35)
Depth	mm (inch)	356 ²⁾ (14.02)	356 ²⁾ (14.02)	545 (21.46)	545 (21.46)	545 (21.46)
Frame size		FX	FX	GX	GX	GX
Weight, approx.	kg (lb)	104 (229)	104 (229)	162 (357)	162 (357)	162 (357)

¹⁾ Max. motor cable length 100 m (328 ft) (shielded) in conjunction with a line filter to maintain the limit values of EN 61800-3 Category C2.

²⁾ Depth = 421 mm (16.6 in) including front cover when CU310 Control Unit is installed.

³⁾ Nominal HP based on Asynchronous motors (induction motors) and 460 V AC. For specific sizing select drive based on motor nameplate current and overload.

SINAMICS S120

Power Modules and line-side components

Power Modules in chassis format

Characteristics

Overload capability

Load cycle data of Power Modules in chassis format

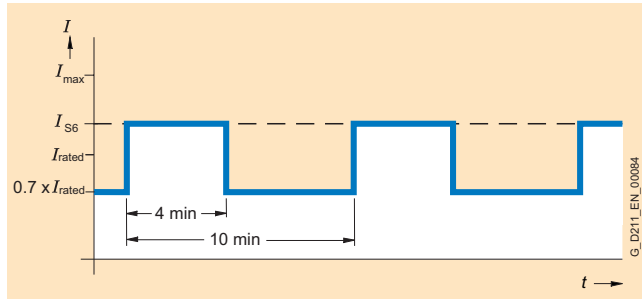

S6 load cycle with previous load with a load cycle period of 600 s

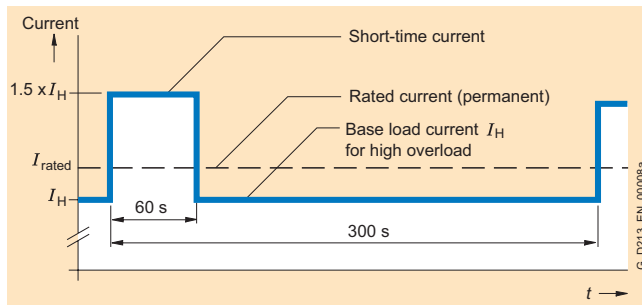

High overload

The base load current I_H is based on a load cycle of 150% for 60 s or 160% for 10 s with a load cycle period of 300 s.

Derating factors

Output current dependent on pulse frequency

Power Module in chassis format	Rated output current A	Derating factor	
		for a pulse frequency of 2.5 kHz	for a pulse frequency of 4 kHz
6SL3310-1TE32-1AA0	210	0.95	0.82
6SL3310-1TE32-6AA0	260	0.95	0.83
6SL3310-1TE33-1AA0	310	0.97	0.88
6SL3310-1TE33-8AA0	380	0.96	0.87
6SL3310-1TE35-0AA0	490	0.94	0.78

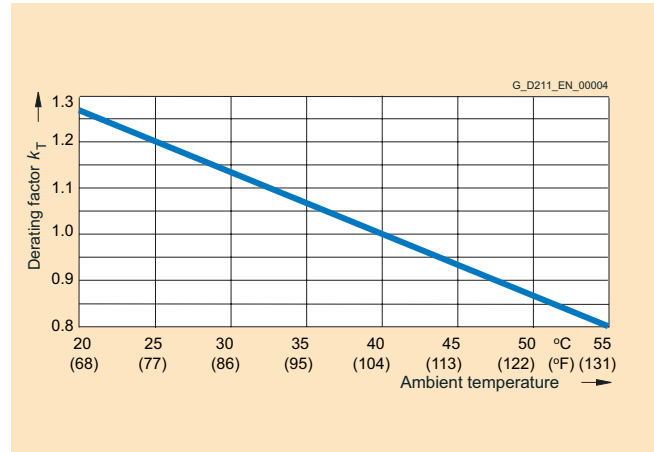

Current derating dependent on ambient temperature

Note: A factor $k_T > 1$ is to be taken into account only in conjunction with current derating as a function of installation altitude, see System Description.

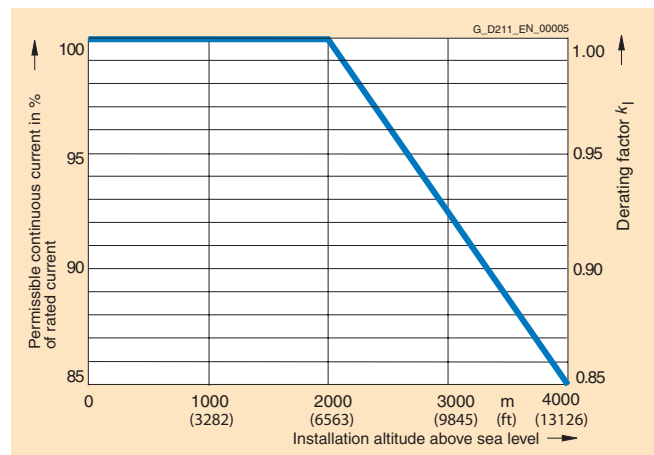

Current derating dependent on installation altitude

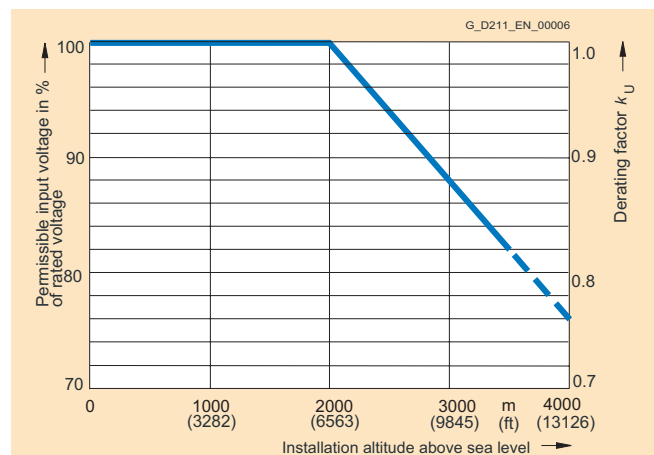

Voltage derating dependent on installation altitude

Overview



Line reactors limit the low-frequency harmonic effects and reduce the load on the rectifiers of the Power Modules. The higher the rated output of the Power Modules, the lower the required inductance of the line reactor. A line reactor is not required where the effective supply impedance equals $u_k > 3\%$. For further information see "System Description".

Technical data

Line voltage 380 V to 480 V 3 AC		Line reactor			
		6SL3000-OCE32-3AA0	6SL3000-OCE32-8AA0	6SL3000-OCE33-3AA0	6SL3000-OCE35-1AA0
Rated current	A	224	278	331	508
Power loss at 50 Hz/60 Hz	kW	0.24/0.27	0.21/0.25	0.23/0.27	0.31/0.37
Line supply connection 1U1, 1V1, 1W1		Flat connector for M10 cable lug	Flat connector for M10 cable lug	Flat connector for M10 cable lug	Flat connector for M12 cable lug
Load connection 1U2, 1V2, 1W2		Flat connector for M10 cable lug	Flat connector for M10 cable lug	Flat connector for M10 cable lug	Flat connector for M12 cable lug
PE connection		M6 screw	M6 screw	M6 screw	M6 screw
Degree of protection		IP00	IP00	IP00	IP00
Width	mm (inch)	270 (10.63)	270 (10.63)	270 (10.63)	300 (11.81)
Height	mm (inch)	248 (9.76)	248 (9.76)	248 (9.76)	269 (10.59)
Depth	mm (inch)	200 (7.87)	200 (7.87)	200 (7.87)	212.5 (8.37)
Weight, approx.	kg (lb)	24.4 (54)	26 (57)	27.8 (61)	38 (84)
Suitable for Power Module	Type	6SL3310-1TE32-1...	6SL3310-1TE32-6...	6SL3310-1TE33-1...	6SL3310-1TE33-8... 6SL3310-1TE35-0...

Selection and ordering data

Rated output current A	Rated power kW (HP)	Suitable for Power Module Type	Line reactor Order No.
Line voltage 380 V to 480 V 3 AC			
210	110 (150)	6SL3310-1TE32-1AA0	6SL3000-OCE32-3AA0
260	132 (200)	6SL3310-1TE32-6AA0	6SL3000-OCE32-8AA0
310	160 (250)	6SL3310-1TE33-1AA0	6SL3000-OCE33-3AA0
380	200 (300)	6SL3310-1TE33-8AA0	6SL3000-OCE35-1AA0
490	250 (400)	6SL3310-1TE35-0AA0	6SL3000-OCE35-1AA0

SINAMICS S120

Power Modules and line-side components

Power Modules in chassis format Line filters

Overview



In plants with strict EMC requirements, line filters work together with line reactors to restrict the conducted interference emanating from the Power Modules to the limit values of Category C2 as defined in EN 61800-3. Line filters are suited only for direct connection to TN (grounded) systems.

Integration

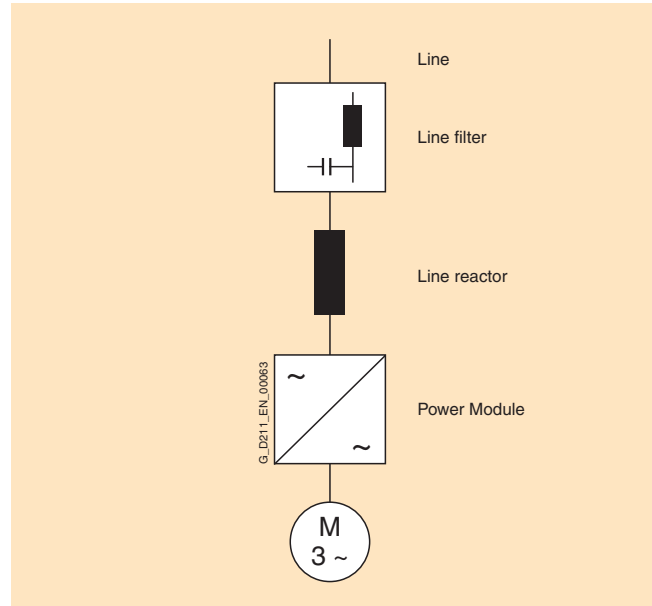

Technical data

Line voltage 380 V to 480 V 3 AC	Line filter			
	6SL3000-0BE32-5AA0	6SL3000-0BE34-4AA0	6SL3000-0BE36-0AA0	
Rated current	A	250	440	600
Power loss	kW	0.05	0.05	0.06
Line supply connection 1U1, 1V1, 1W1		Flat connector for M10 cable lug	Flat connector for M10 cable lug	Flat connector for M10 cable lug
Load connection 1U2, 1V2, 1W2		Flat connector for M10 cable lug	Flat connector for M10 cable lug	Flat connector for M10 cable lug
Degree of protection		IP00	IP00	IP00
Width	mm (inch)	360 (14.17)	360 (14.17)	400 (15.75)
Height	mm (inch)	240 (9.45)	240 (9.45)	265 (10.43)
Depth	mm (inch)	116 (4.57)	116 (4.57)	140 (5.51)
Weight, approx.	kg (lb)	12.5 (28)	12.5 (28)	19 (42)
Suitable for Power Module	Type	6SL3310-1TE32-1...	6SL3310-1TE32-6... 6SL3310-1TE33-1... 6SL3310-1TE33-8...	6SL3310-1TE35-0...

Selection and ordering data

Rated output current A	Rated power kW (HP)	Suitable for Power Module Type	Line filter Order No.
Line voltage 380 V to 480 V 3 AC			
210	110 (150)	6SL3310-1TE32-1AA0	6SL3000-0BE32-5AA0
260	132 (200)	6SL3310-1TE32-6AA0	6SL3000-0BE34-4AA0
310	160 (250)	6SL3310-1TE33-1AA0	6SL3000-0BE34-4AA0
380	200 (300)	6SL3310-1TE33-8AA0	6SL3000-0BE34-4AA0
490	250 (400)	6SL3310-1TE35-0AA0	6SL3000-0BE36-0AA0

SINAMICS S120

Power Modules and line-side components

Power Modules in chassis format Recommended line-side components

Overview

Assignment of line-side power components to Power Modules in blocksize format

Suitable line-side power components are assigned depending on the power rating of the Power Modules.

The following tables list recommended components and apply for ambient temperatures up to 40 °C (104 °F).

Further information about the main contactors, switch disconnectors, fuses and circuit-breakers specified in the tables can be found in Catalogs LV1, LV IT and ET BI.¹⁾

Rated output current	Rated power	Suitable for PM340 Power Module	Main contactor	Circuit-breaker	Main switch (switch disconnector)	Fuse switch disconnector	Switch disconnector with fuse holders	Fuse
A	kW (HP)	Type 6SL3310-...	Type	Order No.	Order No.	Order No.	Order No.	Order No.
Line voltage 380 V to 480 V 3 AC								
210	110 (150)	1TE32-1AA0	3RT1064-...	3VL4725-1DC36-0AA0	3KA5530-1EE01	3NP4270-0CA01	3KL5530-1EB01	3NA3144
260	132 (200)	1TE32-6AA0	3RT1065-...	3VL4731-1DC36-0AA0	3KA5730-1EE01	3NP4370-0CA01	3KL5730-1EB01	3NA3250
310	160 (250)	1TE33-1AA0	3RT1066-...	3VL4740-1DC36-0AA0	3KA5730-1EE01	3NP4370-0CA01	3KL5730-1EB01	3NA3254
380	200 (300)	1TE33-8AA0	3RT1075-...	3VL5750-1DC36-0AA0	3KA5730-1EE01	3NP4370-0CA01	3KL5730-1EB01	3NA3260
490	250 (400)	1TE25-0AA0	3RT1076-...	3VL5763-1DC36-0AA0	3KA5830-1EE01	3NP4470-0CA01	3KL6130-1EB01	3NA3372

¹⁾ Component selections are per IEC standards and not necessarily in accordance with UL or NEC requirements. For NEMA components please see North American Industrial Products Catalog and Speedfax Catalog.

SINAMICS S120

Line Modules and line-side components

Basic Line Modules in chassis format

Overview



A Basic Line Module converts an AC source into an unregulated DC supply. Basic Line Modules are used for applications in which no energy is returned to the supply or where the energy exchange between motor and generator axes takes place in the DC link. The connected Motor Modules are precharged via the thyristor gate control which supplies a DC voltage equal to 1.35 x the line voltage. Basic Line Modules are designed for connection to grounded-neutral (TN, TT) and non-grounded (IT) supply systems.

Design

The Basic Line Modules in chassis format feature the following connections as standard:

- 1 power connection
- 1 connection for the 24 V DC electronics power supply
- 1 DC link connection
- 3 DRIVE-CLiQ sockets

The status of the Basic Line Modules is indicated via two multi-color LEDs.

The scope of supply of the Basic Line Modules includes:

- 0.6 m (1.97 ft) DRIVE-CLiQ cable for connection to a CU320 or SIMOTION D Control Unit
- 1.45 m (4.76 ft) DRIVE-CLiQ cable for connection between the Control Unit and first Motor Module

Selection and ordering data

Infeed power kW (HP)	Basic Line Module in chassis format Order No.
Line voltage 380 V to 480 V 3 AC	
200 (300)	6SL3330-1TE34-2AA0
250 (400)	6SL3330-1TE35-3AA0
400 (600)	6SL3330-1TE38-2AA0
560 (800)	6SL3330-1TE41-2AA0
710 (1000)	6SL3330-1TE41-5AA0
Line voltage 660 V to 690 V 3 AC	
250 (400)	6SL3330-1TH33-0AA0
355 (476)	6SL3330-1TH34-3AA0
560 (800)	6SL3330-1TH36-8AA0
900 (1207)	6SL3330-1TH41-1AA0
1100 (1475)	6SL3330-1TH41-4AA0

Warning signs in foreign languages

Warning signs in other languages can be placed on top of the standard warning signs in German or English.

The following signs are supplied with chassis format units: Chinese, Danish, Finnish, French, Greek, Italian, Japanese, Korean, Dutch, Polish, Portuguese, Russian, Swedish, Spanish, Czech and Turkish.

Integration

The Basic Line Module communicates with a CU320 or SIMOTION D Control Unit via DRIVE-CLiQ.

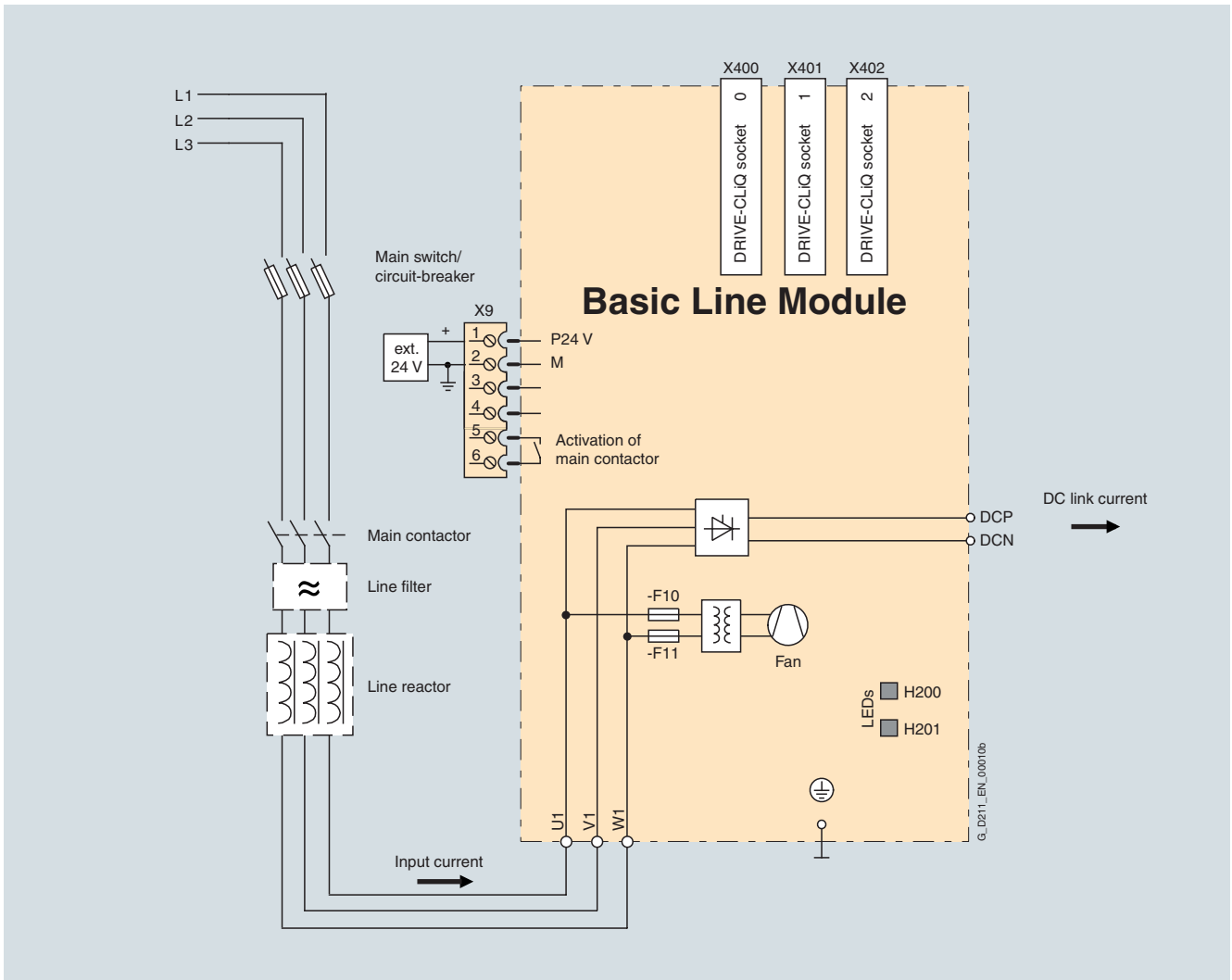

Connection example of Basic Line Module

SINAMICS S120

Line Modules and line-side components

Basic Line Modules in chassis format

Technical data

General technical data

Electrical data	
Line connection voltage (up to 2000 m (6563 ft) above sea level)	380 V to 480 V 3 AC \pm 10% (– 15% < 1 min) or 660 V to 690 V 3 AC \pm 10% (– 15% < 1 min)
Power frequency	47 Hz to 63 Hz
Line power factor at rated output	
• Fundamental Power factor	> 0.96
• Total (λ)	0.75 to 0.93
Overvoltage category	Class III to EN 60664-1
DC link voltage	approx. 1.35 x line voltage ¹⁾
Electronics power supply	24 V DC – 15%/+ 20%
Main contactor control	
• Terminal strip X9/5-6	240 V AC/ max. 8 A 30 V DC/ max. 1 A
Radio interference suppression	
• Standard	No radio interference suppression (Category C3 to EN 61800-3 up to 300 m (984 ft) total cable length)
• With line filter	Category C2 to EN 61800-3
Ambient conditions	
Type of cooling	Forced air cooling through a built-in fan
Permissible ambient and coolant temperature (air) during operation for line-side components, Line Modules and Motor Modules	0 °C to + 40 °C (32 °F to +104° F) without derating, > 40 °C to + 55 °C (> 104 °F to +131 °F)see derating characteristics
Installation altitude	Up to 2000 m (6563 ft) above sea level without derating, > 2000 m (6563 ft) to 4000 m (13126 ft) above sea level see derating characteristics
Certificates	
Conformity	CE (low-voltage and EMC Directives)
Approvals	cULus (File No.: E192450)

¹⁾ The DC link voltage is unregulated and load-dependent. For further information see System Description.

Technical data (continued)

Line voltage 380 V to 480 V 3 AC		Basic Line Modules in chassis format				
		6SL3330-1TE34-2AA0	6SL3330-1TE35-3AA0	6SL3330-1TE38-2AA0	6SL3330-1TE41-2AA0	6SL3330-1TE41-5AA0
Infeed power P_{rated} with 400 V 3 AC with 460 V 3 AC ¹⁾	kW (HP)	200 (300)	250 (400)	400 (600)	560 (800)	710 (1000)
Infeed power for S6 duty (40%) P_{S6}	kW	On request	On request	On request	On request	On request
Max. infeed power P_{max} (HP)	kW	300 (402)	375 (503)	600 (805)	840 (1126)	1065 (1428)
Rated DC link current I_{rated_DC}	A	420	530	820	1200	1500
DC link current I_{H_DC}	A	328	413	640	936	1170
Max. DC link current I_{max_DC}	A	630	795	1230	1800	2250
Input current at $V_{ine} = 400$ V	A	365	460	710	1010	1265
Max. input current at $V_{ine} = 400$ V	A	547	690	1065	1515	1897
Max. current requirement 24 V DC electronics power supply	A	1.1	1.1	1.1	1.1	1.1
DC link capacitance	μF	7200	9600	14600	23200	29000
Max. DC link capacitance of drive group	μF	57600	76800	116800	185600	232000
Efficiency η		0.991	0.992	0.992	0.992	0.992
Power loss	kW	1.9	2.1	3.2	4.6	5.5
Cooling air requirement	m ³ /s (ft ³ /s)	0.17 (6)	0.17 (6)	0.17 (6)	0.36 (12.71)	0.36 (12.71)
Sound pressure level at 50/60 Hz	dB(A)	67/68	67/68	67/68	72/73	72/73
Power connection U1, V1, W1		Flange connection with M10 screw, max. cross section 2 × 185 mm ²	Flange connection with M10 screw, max. cross section 2 × 185 mm ²	Flange connection with M10 screw, max. cross section 2 × 185 mm ²	Flange connection with M12 screw, max. cross section 6 × 240 mm ²	Flange connection with M12 screw, max. cross section 6 × 240 mm ²
DC link connection DCP, DCN		Flange connection with M10 screw, max. cross section 2 × 185 mm ²	Flange connection with M10 screw, max. cross section 2 × 185 mm ²	Flange connection with M10 screw, max. cross section 2 × 185 mm ²	Flange connection with M12 screw, max. cross section 2 × 240 mm ²	Flange connection with M12 screw, max. cross section 2 × 240 mm ²
PE connection		On housing with M10 screw, max. cross section 2 × 185 mm ²	On housing with M10 screw, max. cross section 2 × 185 mm ²	On housing with M10 screw, max. cross section 2 × 185 mm ²	On housing with M10 screw, max. cross section 2 × 240 mm ²	On housing with M10 screw, max. cross section 2 × 240 mm ²
Max. cable length (total of all motor cables and DC link)	m (ft)	1500 (4921)	1500 (4921)	1500 (4921)	2250 (7382)	2250 (7382)
Degree of protection		IP00	IP00	IP00	IP00	IP00
Width	mm (inch)	305 (12)	305 (12)	305 (12)	305 (12)	305 (12)
Height	mm (inch)	1160 (45.67)	1160 (45.67)	1160 (45.67)	1650 (64.96)	1650 (64.96)
Depth	mm (inch)	351 (13.82)	351 (13.82)	351 (13.82)	550 (21.65)	550 (21.65)
Size		FB	FB	FB	GB	GB
Weight, approx.	kg (lb)	86 (190)	86 (190)	86 (190)	214 (472)	214 (472)

1) Nominal HP ratings are provided for ease of assigning components only. The Line Module outputs are dependent on the Motor Module loading and are to be dimensioned accordingly.

SINAMICS S120

Line Modules and line-side components

Basic Line Modules in chassis format

Technical data (continued)

Line voltage 660 V to 690 V 3 AC		Basic Line Modules in chassis format				
		6SL3330-1TH33-0AA0	6SL3330-1TH34-3AA0	6SL3330-1TH36-8AA0	6SL3330-1TH41-1AA0	6SL3330-1TH41-4AA0
Infeed power P_{rated} with 690 V 3 AC	kW	250	355	560	900	1100
Infeed power for S6 duty (40%) P_{S6}	kW	On request	On request	On request	On request	On request
Max. infeed power P_{max} (HP)	kW	375 (503)	532.5 (714)	840 (1126)	1350 (1810)	1650 (2213)
Rated DC link current $I_{\text{rated_DC}}$	A	300	430	680	1100	1400
DC link current I_{H_DC}	A	234	335	530	858	1092
Max. DC link current $I_{\text{max_DC}}$	A	450	645	1020	1650	2100
Input current at $V_{\text{line}} = 690$ V	A	260	375	575	925	1180
Max. input current at $V_{\text{line}} = 690$ V	A	390	562.5	862.5	1387.5	1770
Max. current requirement 24 V DC electronics power supply	A	1.1	1.1	1.1	1.1	1.1
DC link capacitance	μF	3200	4800	7300	11600	15470
Max. DC link capacitance of drive group	μF	25600	38400	58400	92800	123760
Efficiency η		0.994	0.994	0.995	0.994	0.995
Power loss	kW	1.5	2.1	3.0	5.4	5.8
Cooling air requirement	m^3/s (ft^3/s)	0.17 (6)	0.17 (6)	0.17 (6)	0.36 (12.71)	0.36 (12.71)
Sound pressure level at 50/60 Hz	dB(A)	67/68	67/68	67/68	72/73	72/73
Power connection U1, V1, W1		Flange connection with M10 screw, max. cross section $2 \times 185 \text{ mm}^2$ with adapter max. cross section $3 \times$ 240 mm^2	Flange connection with M10 screw, max. cross section $2 \times 185 \text{ mm}^2$ with adapter max. cross section $3 \times$ 240 mm^2	Flange connection with M10 screw, max. cross section $2 \times 185 \text{ mm}^2$ with adapter max. cross section $3 \times$ 240 mm^2	Flange connection for busbar connection with M12 screw or with adapter max. cross section $6 \times 240 \text{ mm}^2$	Flange connection for busbar connection with M12 screw or with adapter max. cross section $6 \times 240 \text{ mm}^2$
DC link connection DCP, DCN		Flange connection with M10 screw, max. cross section $2 \times 185 \text{ mm}^2$ with adapter max. cross section $3 \times$ 240 mm^2	Flange connection with M10 screw, max. cross section $2 \times 185 \text{ mm}^2$ with adapter max. cross section $3 \times$ 240 mm^2	Flange connection with M10 screw, max. cross section $2 \times 185 \text{ mm}^2$ with adapter max. cross section $3 \times$ 240 mm^2	Flange connection for busbar connection with M12 screw or with adapter max. cross section $6 \times 240 \text{ mm}^2$	Flange connection for busbar connection with M12 screw or with adapter max. cross section $6 \times 240 \text{ mm}^2$
PE connection		On housing with M10 screw, max. cross section $2 \times 185 \text{ mm}^2$	On housing with M10 screw, max. cross section $2 \times 185 \text{ mm}^2$	On housing with M10 screw, max. cross section $2 \times 185 \text{ mm}^2$	On housing with M12 screw, max. cross section $4 \times 240 \text{ mm}^2$	On housing with M12 screw, max. cross section $4 \times 240 \text{ mm}^2$
Max. cable length (total of all motor cables and DC link)	m (ft)	1500 (4921)	1500 (4921)	1500 (4921)	2250 (7382)	2250 (7382)
Degree of protection		IP00	IP00	IP00	IP00	IP00
Width	mm (inch)	305 (12)	305 (12)	305 (12)	305 (12)	305 (12)
Height	mm (inch)	1160 (45.67)	1160 (45.67)	1160 (45.67)	1650 (64.96)	1650 (64.96)
Depth	mm (inch)	351 (13.82)	351 (13.82)	351 (13.82)	550 (21.65)	550 (21.65)
Size		FB	FB	FB	GB	GB
Weight, approx.	kg (lb)	86 (190)	86 (190)	86 (190)	214 (472)	214 (472)

Characteristics

Overload capability

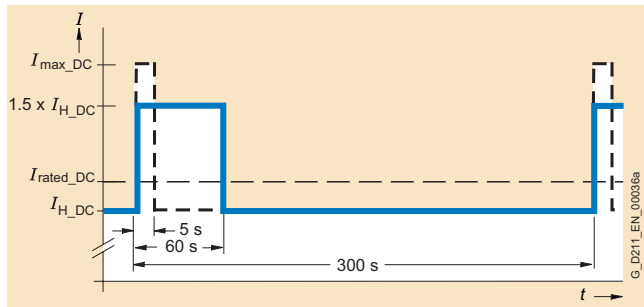

Overload capability

Derating characteristics

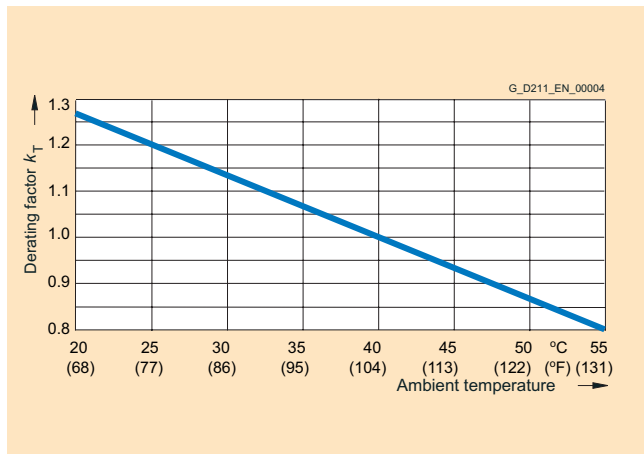

Current derating dependent on ambient temperature

Note: A derating factor $k_T > 1.0$ is to be taken into account only in conjunction with "current derating dependent on installation altitude". See also System description.

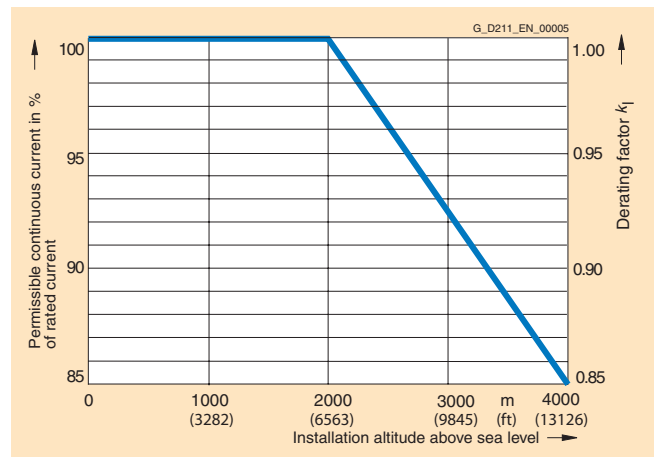

Current derating dependent on installation altitude

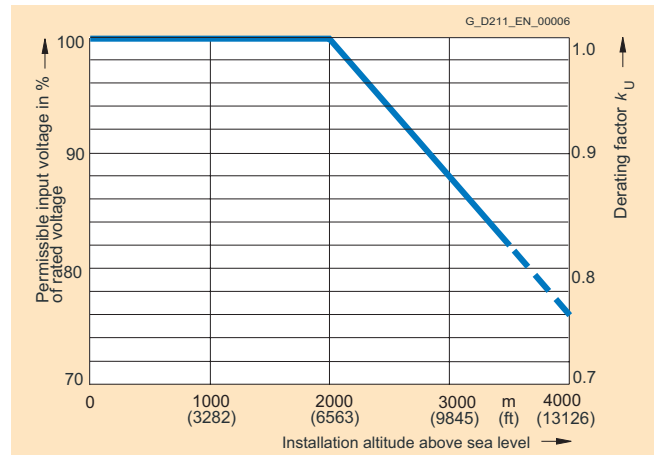

Voltage derating dependent on installation altitude

SINAMICS S120

Line Modules and line-side components

Basic Line Modules in chassis format

Line reactors

Overview



Line reactors reduce harmonic currents on the supply system and limit commutating dips in the Basic Line Module. For this reason, line reactors should always be used.

Selection and ordering data

Infeed power of the Basic Line Module kW (HP)	Suitable for Basic Line Module	Line reactor Order No.
Line voltage 380 V to 480 V 3 AC		
200 (300)	6SL3330-1TE34-2AA0	6SL3000-OCE35-1AA0
250 (400)	6SL3330-1TE35-3AA0	6SL3000-OCE35-1AA0
400 (600)	6SL3330-1TE38-2AA0	6SL3000-OCE37-7AA0
560 (800)	6SL3330-1TE41-2AA0	6SL3000-OCE41-0AA0
710 (1000)	6SL3330-1TE41-5AA0	6SL3000-OCE41-5AA0
Line voltage 660 V to 690 V 3 AC		
250	6SL3330-1TH33-0AA0	6SL3000-0CH32-7AA0
355	6SL3330-1TH34-3AA0	6SL3000-0CH34-8AA0
560	6SL3330-1TH36-8AA0	6SL3000-0CH36-0AA0
900	6SL3330-1TH41-1AA0	6SL3000-0CH41-2AA0
1100	6SL3330-1TH41-4AA0	6SL3000-0CH41-2AA0

Technical data

Line voltage 380 V to 480 V 3 AC		Line reactor 6SL3000-OCE35-1AA0		6SL3000- OCE37-7AA0	6SL3000- OCE41-0AA0	6SL3000- OCE41-5AA0
Max. thermal current $I_{th\ max}$	A	508	508	773	1022	1485
Power loss 50 Hz/60 Hz	kW	0.292/0.328	0.323/0.365	0.310/0.351	0.441/0.498	0.687/0.776
Line/load connection		M12 connecting lugs	M12 connecting lugs	M12 connecting lugs	M12 connecting lugs	M12 connecting lugs
Degree of protection		IP00	IP00	IP00	IP00	IP00
Width	mm (inch)	300 (11.81)	300 (11.81)	300 (11.81)	350 (13.78)	460 (18.11)
Height	mm (inch)	269 (10.59)	269 (10.59)	269 (10.59)	321 (12.64)	435 (17.13)
Depth	mm (inch)	212.5 (8.37)	212.5 (8.37)	212.5 (8.37)	211.5 (8.33)	235 (9.25)
Weight, approx.	kg (lb)	38.0 (84)	38.0 (84)	51.3 (113)	69.6 (154)	118 (260)
Suitable for Basic Line Module	Type	6SL3330-1TE34-2AA0	6SL3330-1TE35-3AA0	6SL3330-1TE38-2AA0	6SL3330-1TE41-2AA0	6SL3330-1TE41-5AA0

Line voltage 660 V to 690 V 3 AC		Line reactor 6SL3000- 0CH32-7AA0	6SL3000- 0CH34-8AA0	6SL3000- 0CH36-0AA0	6SL3000-0CH41-2AA0	
Max. thermal current $I_{th\ max}$	A	270	482	597	1167	1167
Power loss 50 Hz/60 Hz	kW	0.245/0.277	0.424/0.478	0.430/0.485	0.620/0.697	0.693/0.783
Line/load connection		M10 connecting lugs	M12 connecting lugs	M12 connecting lugs	M12 connecting lugs	M12 connecting lugs
Degree of protection		IP00	IP00	IP00	IP00	IP00
Width	mm (inch)	270 (10.63)	350 (13.78)	350 (13.78)	460 (18.11)	460 (18.11)
Height	mm (inch)	248 (9.76)	321 (12.64)	321 (12.64)	435 (17.13)	435 (17.13)
Depth	mm (inch)	200 (7.87)	232.5 (9.15)	232.5 (9.15)	235 (9.25)	235 (9.25)
Weight, approx.	kg (lb)	27.9 (62)	55.6 (123)	63.8 (141)	147 (324)	147 (324)
Suitable for Basic Line Module	Type	6SL3330-1TH33-0AA0	6SL3330-1TH34-3AA0	6SL3330-1TH36-8AA0	6SL3330-1TH41-1AA0	6SL3330-1TH41-4AA0

SINAMICS S120

Line Modules and line-side components

Basic Line Modules in chassis format Line filters

Overview



In plants with strict EMC requirements, line filters work together with line reactors to restrict the conducted interference emanating from the power modules to the limit values of Category C2 as defined in EN 61800-3. Line filters are suited only for direct connection to TN (grounded) systems.

Selection and ordering data

Infeed power of the Basic Line Module kW (HP)	Suitable for Basic Line Module	Line filter Order No.
Line voltage 380 V to 480 V 3 AC		
200 (300)	6SL3330-1TE34-2AA0	6SL3000-0BE34-4AA0
250 (400)	6SL3330-1TE35-3AA0	6SL3000-0BE36-0AA0
400 (600)	6SL3330-1TE38-2AA0	6SL3000-0BE41-2AA0
560 (800)	6SL3330-1TE41-2AA0	6SL3000-0BE41-2AA0
710 (1000)	6SL3330-1TE41-5AA0	6SL3000-0BE41-6AA0
Line voltage 660 V to 690 V 3 AC		
250	6SL3330-1TH33-0AA0	6SL3000-0BG34-4AA0
355	6SL3330-1TH34-3AA0	6SL3000-0BG34-4AA0
560	6SL3330-1TH36-8AA0	6SL3000-0BG36-0AA0
900	6SL3330-1TH41-1AA0	6SL3000-0BG41-2AA0
1100	6SL3330-1TH41-4AA0	6SL3000-0BG41-2AA0

Technical data

Line voltage 380 V to 480 V 3 AC		Line filter			
		6SL3000-0BE34-4AA0	6SL3000-0BE36-0AA0	6SL3000-0BE41-2AA0	6SL3000-0BE41-6AA0
Rated current	A	440	600	1200	1600
Power loss	kW	0.049	0.055	0.137	0.182
Line/load connection L1, L2, L3 / L1', L2', L3'		M10 connecting lugs	M10 connecting lugs	M12 connecting lugs	M12 connecting lugs
PE connection		On housing with M8 bolt	On housing with M10 bolt	On housing with M10 bolt	On housing with M10 bolt
Degree of protection		IP00	IP00	IP00	IP00
Width	mm (inch)	360 (14.17)	400 (15.75)	425 (16.73)	505 (19.88)
Height	mm (inch)	240 (9.45)	265 (10.43)	265 (10.43)	265 (10.43)
Depth	mm (inch)	116 (4.57)	140 (5.51)	145 (5.71)	145 (5.71)
Weight, approx.	kg (lb)	12.3 (27)	19.0 (42)	25.2 (56)	28.8 (64)
Suitable for Basic Line Module	Type	6SL3330-1TE34-2AA0	6SL3330-1TE35-3AA0	6SL3330-1TE38-2AA0 6SL3330-1TE41-5AA0	6SL3330-1TE41-5AA0

Line voltage 660 V to 690 V 3 AC		Line filter		
		6SL3000-0BG34-4AA0	6SL3000-0BG36-0AA0	6SL3000-0BG41-2AA0
Rated current	A	440	600	1200
Power loss	kW	0.049	0.055	0.137
Line/load connection L1, L2, L3 / L1', L2', L3'		M10 connecting lugs	M10 connecting lugs	M12 connecting lugs
PE connection		On housing with M8 bolt	On housing with M10 bolt	On housing with M10 bolt
Degree of protection		IP00	IP00	IP00
Width	mm (inch)	360 (14.17)	360 (14.17)	425 (16.73)
Height	mm (inch)	240 (9.45)	240 (9.45)	265 (10.43)
Depth	mm (inch)	116 (4.57)	116 (4.57)	145 (5.71)
Weight, approx.	kg (lb)	12.3 (27)	19.0 (42)	25.2 (56)
Suitable for Basic Line Module	Type	6SL3330-1TH33-0AA0 6SL3330-1TH34-3AA0	6SL3330-1TH36-8AA0	6SL3330-1TH41-1AA0 6SL3330-1TH41-4AA0

SINAMICS S120

Line Modules and line-side components

Basic Line Modules in chassis format Recommended line-side components

Overview

Assignment of line-side power components to Basic Line Modules in chassis format

Suitable line-side power components are assigned depending on the power rating of the Basic Line Module.

The tables below list recommended components.

Further information about the main contactors, switch disconnectors, fuses and circuit-breakers specified in the tables can be found in Catalogs LV 1, LV IT and ET BI.¹⁾

Infeed power	Input current	Suitable for Basic Line Module	Main contactor	Fixed-mounted circuit-breaker	Switch disconnector without handle and shaft	Switch disconnector with handle and shaft
kW (HP)	A	Type 6SL3330-...	Type	Order No.	Order No.	Order No.
Line voltage 380 V to 480 V 3 AC						
200 (300)	365	1TE34-2AA0	3RT1075-...	–	3KL6130-1AB02	3KL6130-1EB02
250 (400)	460	1TE35-3AA0	3RT1076-...	–	3KL6130-1AB02	3KL6130-1EB02
400 (600)	710	1TE38-2AA0	3RT1066-... (x 3)	–	3KL6230-1AB02	3KL6230-1EB02
560 (800)	1010	1TE41-2AA0	–	3WL1112-2BB34-4AN2-Z C22	–	–
710 (1000)	1265	1TE41-5AA0	–	3WL1116-2BB34-4AN2-Z C22	–	–
Line voltage 660 V to 690 V 3 AC						
250	260	1TH33-0AA0	3RT1066-...	–	3KL5730-1AB01	3KL5730-1EB01
355	375	1TH34-3AA0	3RT1476-6AP36	–	3KL6130-1AB02	3KL6130-1EB02
560	575	1TH36-8AA0	3RT1476-6AP36	–	3KL6130-1AB02	3KL6130-1EB02
900	925	1TH41-1AA0	–	3WL1210-4BB34-4AN2-Z C22	–	–
1100	1180	1TH41-4AA0	–	3WL1212-4BB34-4AN2-Z C22	–	–

Infeed power	Input current	Suitable for Basic Line Module	Cable protection fuse		Cable protection fuse incl. semiconductor protection	
kW (HP)	A	Type 6SL3330-...	Order No.	Rated current A	Order No.	Rated current A
Line voltage 380 V to 480 V 3 AC						
200 (300)	365	1TE34-2AA0	3NA3365	500	3NE1333-2	450
250 (400)	460	1TE35-3AA0	3NA3372	630	3NE1334-2	500
400 (600)	710	1TE38-2AA0	3NA3475	800	3NE1448-2^{*)}	800
560 (800)	1010	1TE41-2AA0	3NA3482	1250	3NE1435-2 (x 2)	2 × 560
710 (1000)	1265	1TE41-5AA0	3NA3475 (x 2)	2 × 800	3NE1437-2 (x 2)	2 × 710
Line voltage 660 V to 690 V 3 AC						
250	260	1TH33-0AA0	3NA3252-6	315	3NE1230-2	315
355	375	1TH34-3AA0	3NA3365-6	500	3NE1333-2^{*)}	450
560	575	1TH36-8AA0	3NA3252-6 (x 2)	2 × 315	3NE1436-2^{*)}	630
900	925	1TH41-1AA0	3NA3365-6 (x 2)	2 × 500	3NE1334-2 (x 2)	2 × 500
1100	1180	1TH41-4AA0	3NA3365-6 (x 3)	3 × 500	3NE1436-2^{*)} (x 2)	2 × 630

¹⁾ Component selections are per IEC standards and not necessarily in accordance with UL or NEC requirements. For NEMA components please see North American Industrial Products Catalog and Speedfax Catalog.

^{*)} No semiconductor protection.

Overview



Smart Line Modules are non-regulated feed/feedback units (diode bridge for incoming supply; line-commutated feedback via IGBTs) with 100% regenerative feedback power. The regenerative feedback capability of the modules can be deactivated by means of a digital input. Smart Line Modules are designed for connection to grounded-neutral (TN, TT) and non-grounded (IT) supply systems.

The DC link is pre-charged via integrated precharging resistors.

Design

The Smart Line Modules in booksize format feature the following interfaces as standard:

- 1 power connection via screw-type terminals
- 1 connection for the 24 V DC electronics power supply via the 24 V terminal adapter included in the scope of supply
- 1 DC link connection via integrated DC link busbars
- 2 PE (protective earth) connections
- 2 digital inputs (5 kW (5 HP) and 10 kW (10 HP) on Smart Line Modules only)
- 1 x digital output (5 kW (5 HP) and 10 kW (10 HP) on Smart Line Modules only)
- 3 DRIVE-CLiQ sockets (16 kW (18 HP) and 36 kW (40 HP) on Smart Line Modules only)

The status of the Smart Line Modules is indicated via two multi-color LEDs.

The signal cable shield can be connected to the Line Module by means of a shield connection terminal, e.g. Weidmüller type KLBU 3-8 SC.

The scope of supply of the Smart Line Modules includes:

- DRIVE-CLiQ cable for connection to the Control Unit on the immediate left for drive control (on 16 kW (18 HP) and 36 kW (40 HP) Smart Line Modules only)
- DRIVE-CLiQ cable (length depends on module width) to connect Smart Line Modules to adjacent Motor Module
- Jumper for connecting the 24 V DC busbar to the adjacent Motor Module
- 24 V terminal adapter (X24)
- Connector X21 for digital inputs and outputs
- Connector X22 for digital inputs and outputs (5 kW (5 HP) and 10 kW (10 HP) on Smart Line Modules only)
- Connector X1 for line supply connection (5 kW (5 HP) and 10 kW (10 HP) on Smart Line Modules only)

SINAMICS S120

Line Modules and line-side components

Smart Line Modules in booksize format

Integration

2

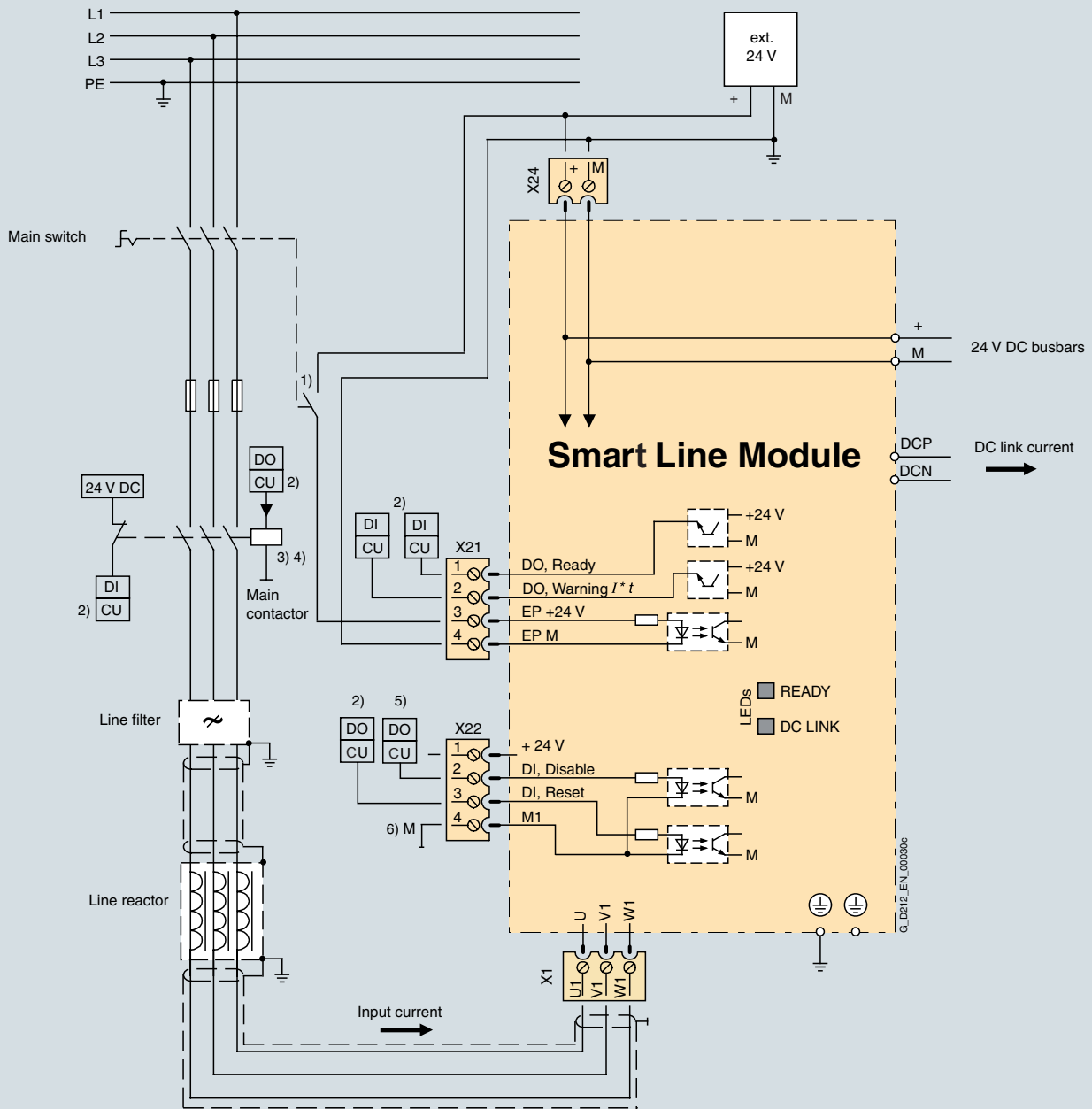

- 1) Leading NC contact $t > 10$ ms, 24 V DC and ground must be connected for operation.
- 2) Digital input (DI) or digital output (DO) controlled by the Control Unit.
- 3) No additional load permitted downstream of the main contactor.
- 4) The current capacity of the digital output (DO) must be taken into account; an output interface element may have to be used.
- 5) Digital output (DO) = High means: feedback deactivated (a jumper can be inserted between X22 pins 1 and 2 for permanent deactivation).
- 6) X22 pin 4 must be connected to ground (ext. 24 V).

Connection example of 5 kW (5 HP) and 10 kW (10 HP) Smart Line Modules

Integration (continued)

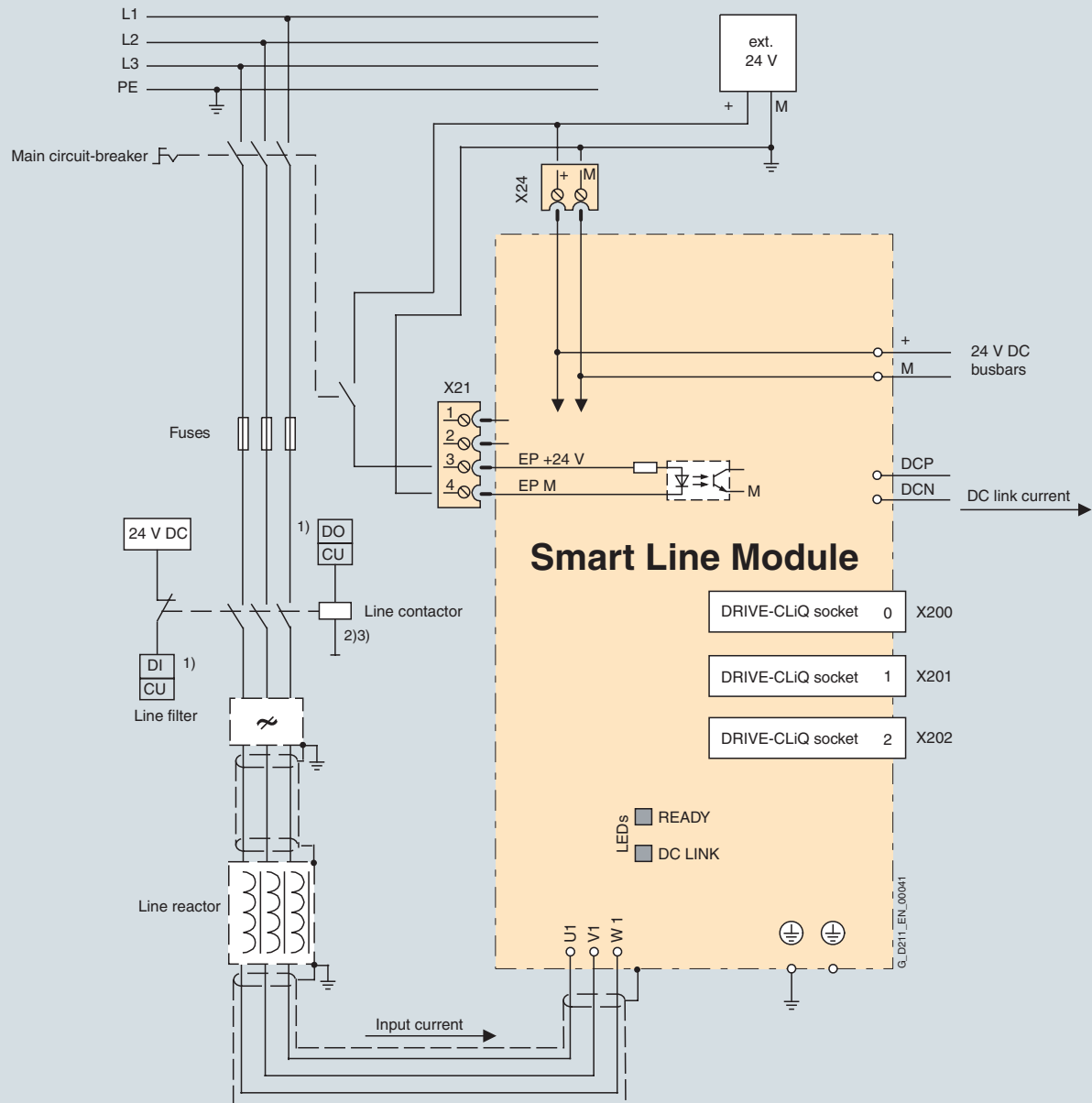

- 1) Digital input (DI) or digital output (DO), controlled via Control Unit.
- 2) No additional load permitted downstream of the line contactor.
- 3) The current load of the digital output (DO) must be observed; an output interface may have to be used.

Connection example of 16 kW (18 HP) and 36 kW (40 HP) Smart Line Modules

SINAMICS S120

Line Modules and line-side components

Smart Line Modules in booksize format

Technical data

General technical data

Electrical data	
Line connection voltage (up to 2000 m (6563 ft) above sea level)	380 V to 480 V 3 AC $\pm 10\%$ (– 15% < 1 min)
Power frequency	47 Hz to 63 Hz
Line power factor at rated output	
• Fundamental Power Factor	> 0.96
• Total (λ)	0.65 to 0.90
Overtoltage category	Class III to EN 60664-1
DC link voltage	approx. 1.35 x line voltage ¹⁾
Electronics power supply	24 V DC – 15%/+ 20%
Radio interference suppression	
• Standard	No radio interference suppression
• With line filter	Class A1 to EN 55011 and Category C2 to EN 61800-3
Ambient conditions	
Type of cooling	Forced air cooling through a built-in fan
Permissible ambient and coolant temperature (air) during operation for line-side components, Line Modules and Motor Modules	0 °C to + 40 °C (32 °F to +104°F) without derating, > 40°C to + 55 °C (> 104 °F to +131 °F) see derating characteristics
Installation altitude	Up to 1000 m (1328 ft) above sea level without derating, > 1000 m (1328 ft) to 4000 (13126 ft) m above sea level see derating characteristics
Certificates	
Conformity	CE (low-voltage and EMC Directives)
Approvals	cULus (File No.: E192450)

¹⁾ The DC link voltage is unregulated and load-dependent. For further information see System Description.

Technical data (continued)

Line voltage 380 V to 480 V 3 AC	Smart Line Modules in booksize format				
		6SL3130-6AE15-0AA0	6SL3130-6AE21-0AA0	–	–
Internal air cooling					
Internal air cooling with varnished modules		6SL3130-6AE15-0AB0	6SL3130-6AE21-0AB0	6SL3130-6TE21-6AB0	6SL3130-6TE23-6AB0
External air cooling		6SL3131-6AE15-0AA0	6SL3131-6AE21-0AA0	–	–
Rated feed/feedback power P_{rated} with 380 V 3 AC with 460 V 3 AC ²⁾	kW (HP)	5 (5)	10 (10)	16 (18)	36 (40)
I/RF power for S6 duty (40%) P_{S6}	kW	6.5	13	21	47
Max. I/RF power P_{max}	kW	10	20	35	70
DC link current at 600 V DC	A	8.3	16.6	27	60
DC link current for S6 duty (40%)	A	11	22	35	79
Max. DC link current	A	16.6	33.2	59	117
Rated input current with 380 V 3 AC	A	12	24	26	58
Input current for S6 duty (40%)	A	15.6	31.2	35	79
Max. input current	A	22	44	59	117
Max. current requirement 24 V DC electronics power supply	A	1.0	1.3	1.1	1.5
24 V DC busbar current capacity	A	20	20	20	20
DC link capacitance	μF	220	330	710	1410
Max. DC link capacitance of drive group	μF	6000	6000	20000	20000
DC link busbar current capacity	A	100	100	100	100
Efficiency η		0.98	0.98	0.99	0.99
Power loss ¹⁾ with internal air cooling	kW	0.09	0.17	0.17	0.37
Power loss ¹⁾ with external air cooling int./ext.	kW	0.04/0.05	0.065/0.105	–	–
Cooling air requirement	m ³ /s (ft ³ /s)	0.008 (0.283)	0.008 (0.283)	0.016 (0.565)	0.031 (1.095)
Sound pressure level	dB(A)	< 60	< 60	< 60	< 60
Power connection U1, V1, W1		Screw-type terminals 2.5 mm ² to 6 mm ² (X1)	Screw-type terminals 2.5 mm ² to 6 mm ² (X1)	Screw-type terminals 2.5 mm ² to 10 mm ² (X1)	M6 screw studs for ring terminal ends 2.5 mm ² to 50 mm ² (X1)
Shield connection		Cable shield connec- tion plate integrated into the connector	Cable shield connec- tion plate integrated into the connector	Cable shield connec- tion plate integrated into the connector	see Accessories
PE connection		On housing with M5 screw	On housing with M5 screw	On housing with M5 screw	On housing with M6 screw
Max. cable length (total of all motor power cables and DC link)	m (ft)	350 (1150) shielded 560 (1838) unshielded	350 (1150) shielded 560 (1838) unshielded	350 (1150) shielded 560 (1838) unshielded	350 (1150) shielded 560 (1838) unshielded
Degree of protection		IP20	IP20	IP20	IP20
Width	mm (inch)	50 (1.97)	50 (1.97)	100 (3.94)	150 (5.91)
Height	mm (inch)	380 (14.96)	380 (14.96)	380 (14.96)	380 (14.96)
Depth with internal air cooling	mm (inch)	270 (10.63)	270 (10.63)	270 (10.63)	270 (10.63)
Depth with external air cooling on/behind mounting surface	mm (inch)	226/66.5 (8.9/2.6)	226/66.5 (8.9/2.6)	–	–
Approx. weight with internal air cooling	kg (lb)	4.7 (10)	4.8 (11)	7 (15)	10.3 (23)
Approx. weight with external air cooling	kg (lb)	5.3 (12)	5.4 (12)	–	–

¹⁾ Power loss of Smart Line Module at rated output without losses of 24 V DC electronics power supply.

²⁾ Nominal HP ratings are provided for ease of assigning components only. The Line Module outputs are dependent on the Motor Module loading and are to be dimensioned accordingly.

SINAMICS S120

Line Modules and line-side components

Smart Line Modules in booksize format

Selection and ordering data

Rated infeed power kW (HP)	Smart Line Module in booksize format		
	Internal air cooling Order No.	Internal air cooling with varnished modules Order No.	External air cooling Order No.
Line voltage 380 V to 480 V 3 AC			
5 (5)	6SL3130-6AE15-0AA0	6SL3130-6AE15-0AB0	6SL3131-6AE15-0AA0
10 (10)	6SL3130-6AE21-0AA0	6SL3130-6AE21-0AB0	6SL3131-6AE21-0AA0
16 (18)	–	6SL3130-6TE21-6AB0	–
36 (40)	–	6SL3130-6TE23-6AB0	–

Accessories

Description	Order No.
Shield connection kit for Line/Motor Modules in booksize format with a width of 150 mm (5.91 in)	6SL3162-1AF00-0AA0
DC link supply adapter for direct infeed of DC link voltage <ul style="list-style-type: none"> Screw-type terminals 0.5 mm² to 10 mm² for Line Modules and Motor Modules in booksize format with a width of 50 mm (1.97 in) or 100 mm (3.94 in) Screw-type terminals 35 mm² to 95 mm² for Line Modules and Motor Modules in booksize format with a width of 150 mm (5.91 in), 200 mm (7.87 in) and 300 mm (11.81 in) 	6SL3162-2BD00-0AA0 6SL3162-2BM00-0AA0
DC link adapters (2x) for multi-tier configuration Screw-type terminals 35 mm ² to 95 mm ² for all Line Modules and Motor Modules in booksize format	6SL3162-2BM01-0AA0
24 V terminal adapter for all Line Modules and Motor Modules in booksize format	6SL3162-2AA00-0AA0
24 V jumper for connection of the 24 V busbars (for booksize format)	6SL3162-2AA01-0AA0
Warning signs in foreign languages This set of foreign language warning signs can be placed on top of the standard German or English signs. One sign in each of the following languages is provided in each set: Chinese Simplified, Danish, Dutch, Finnish, French, Greek, Italian, Japanese, Korean, Portuguese, Spanish and Swedish.	6SL3166-3AB00-0AA0

Characteristics

Overload capability

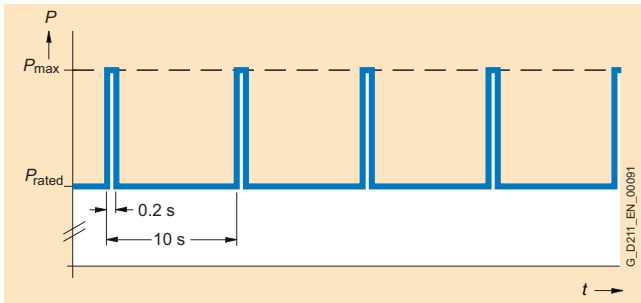

Load cycle with previous load

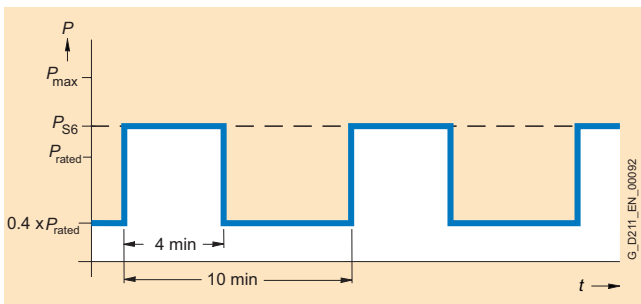

S6 load cycle with previous load

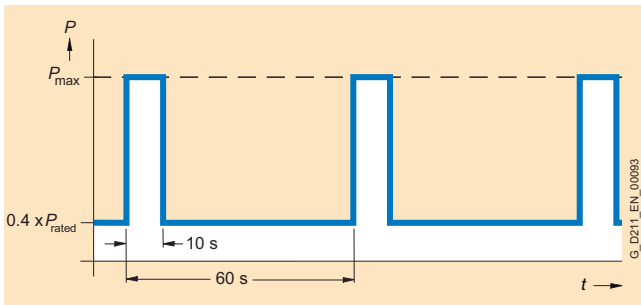

S6 load cycle with previous load

Derating characteristics

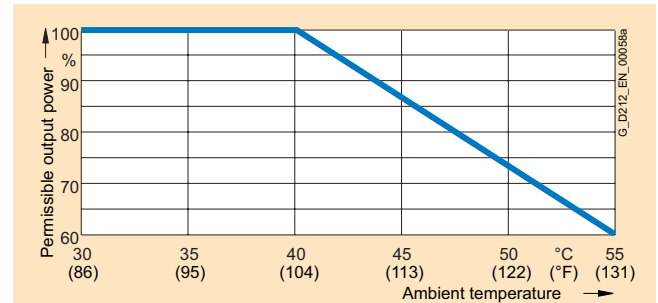

Output rating dependent on ambient temperature

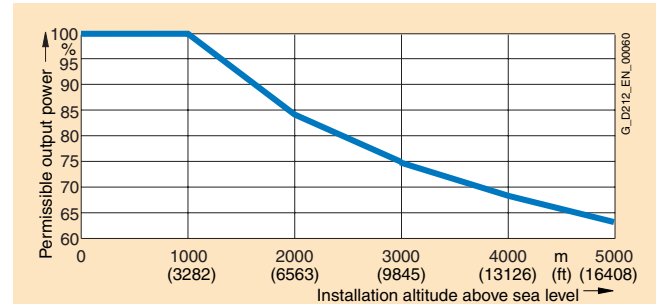

Output rating dependent on installation altitude

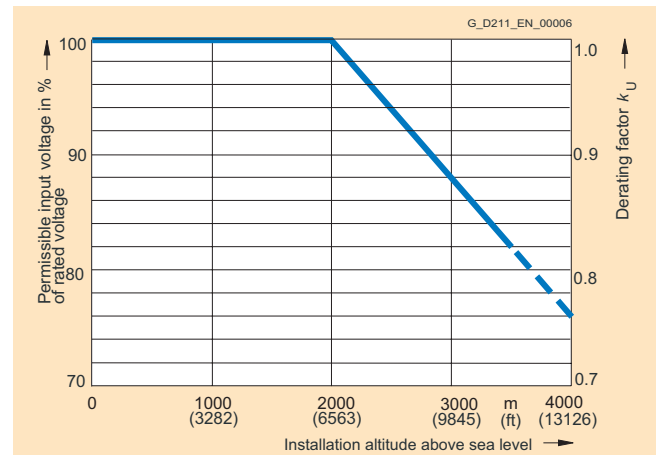

Voltage derating dependent on installation altitude

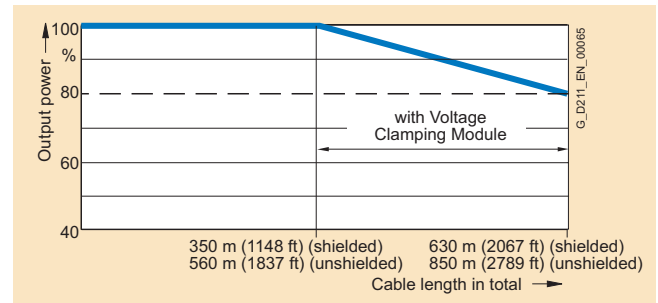

Output rating dependent on total cable length

SINAMICS S120

Line Modules and line-side components

Smart Line Modules in booksize format Line reactors

Overview



Smart Line Modules are not warranted to operate without the specified line reactors. The use of other makes of line reactor can lead to malfunctions or irreparable damage to equipment.

Selection and ordering data

Rated infeed power of the Smart Line Module kW (HP)	Suitable for Smart Line Module	Line reactor Order No.
Line voltage 380 V to 480 V 3 AC		
5 (5)	6SL3130-6AE15-0AA0 6SL3130-6AE15-0AB0 6SL3131-6AE15-0AA0	6SL3000-OCE15-0AA0
10 (10)	6SL3130-6AE21-0AA0 6SL3130-6AE21-0AB0 6SL3131-6AE21-0AA0	6SL3000-OCE21-0AA0
16 (18)	6SL3130-6TE21-6AB0	6SL3000-OCE21-6AA0
36 (40)	6SL3130-6TE23-6AB0	6SL3000-OCE23-6AA0

Technical data

Line voltage 380 V to 480 V 3 AC		Line reactor			
		6SL3000-OCE15-0AA0	6SL3000-OCE21-0AA0	6SL3000-OCE21-6AA0	6SL3000-OCE23-6AA0
Rated current	A	14	28	35	69
Power loss	kW	0.062	0.116	0.11	0.17
Line/load connection 1U1, 1V1, 1W1 / 1U2, 1V2, 1W2		4 mm ² screw-type terminals	10 mm ² screw-type terminals	10 mm ² screw-type terminals	16 mm ² screw-type terminals
PE connection		4 mm ² screw-type terminals	10 mm ² screw-type terminals	10 mm ² screw-type terminals	16 mm ² screw-type terminals
Degree of protection		IP20	IP20	IP20	IP20
Width	mm (inch)	150 (5.91)	177 (6.97)	219 (8.62)	228 (8.98)
Height	mm (inch)	175 (6.89)	196 (7.72)	180 (7.09)	235 (9.25)
Depth	mm (inch)	90 (3.54)	110 (4.33)	144 (5.67)	224 (8.82)
Weight, approx.	kg (lb)	3.7 (8)	7.5 (17)	9.5 (21)	17 (38)
Suitable for Smart Line Module	Type	6SL3130-6AE15-0AA0 6SL3130-6AE15-0AB0 6SL3131-6AE15-0AA0	6SL3130-6AE21-0AA0 6SL3130-6AE21-0AB0 6SL3131-6AE21-0AA0	6SL3130-6TE21-6AB0	6SL3130-6TE23-6AB0

SINAMICS S120

Line Modules and line-side components

Smart Line Modules in booksize format
Line filters

Overview



In plants with strict EMC requirements, line filters work together with line reactors to restrict the conducted interference emanating from the Power Modules to the limit values of Class A1 as defined in EN 55011 and Category C2 as defined in EN 61800-3. Line filters are suited only for direct connection to TN (grounded) systems.

Selection and ordering data

Rated infeed power of the Smart Line Module kW (HP)	Suitable for Smart Line Module	Line filter Order No.
Line voltage 380 V to 480 V 3 AC		
5 (5)	6SL3130-6AE15-0AA0 6SL3130-6AE15-0AB0 6SL3131-6AE15-0AA0	6SL3000-0HE15-0AA0
10 (10)	6SL3130-6AE21-0AA0 6SL3130-6AE21-0AB0 6SL3131-6AE21-0AA0	6SL3000-0HE21-0AA0
16 (18)	6SL3130-6TE21-6AB0	6SL3000-0BE21-6DA0
36 (40)	6SL3130-6TE23-6AB0	6SL3000-0BE23-6DA0

Technical data

Line voltage 380 V to 480 V 3 AC		Line filter			
		6SL3000-0HE15-0AA0	6SL3000-0HE21-0AA0	6SL3000-0BE21-6DA0	6SL3000-0BE23-6DA0
Rated current	A	16	25	36	65
Power loss	W	20	20	6	10
Line/load connection L1, L2, L3 / U, V, W		10 mm ² screw-type terminals	10 mm ² screw-type terminals	10 mm ² screw-type terminals	35 mm ² screw-type terminals
PE connection		On housing with M6 bolt	On housing with M6 bolt	On housing with M6 bolt	On housing with M6 bolt
Degree of protection		IP20	IP20	IP20	IP20
Width	mm (inch)	60 (2.36)	60 (2.36)	50 (1.97)	75 (2.95)
Height	mm (inch)	285 (11.22)	285 (11.22)	420 (16.54)	420 (16.54)
Depth	mm (inch)	122 (4.8)	122 (4.8)	226 (8.9)	226 (8.9)
Weight, approx.	kg(lb)	3.8 (8)	5.7 (13)	5.0 (11)	6.5 (14)
Suitable for Smart Line Module	Type	6SL3130-6AE15-0AA0 6SL3130-6AE15-0AB0 6SL3131-6AE15-0AA0	6SL3130-6AE21-0AA0 6SL3130-6AE21-0AB0 6SL3131-6AE21-0AA0	6SL3130-6TE21-6AB0	6SL3130-6TE23-6AB0

SINAMICS S120

Line Modules and line-side components

Smart Line Modules in booksize format Recommended line-side components

Overview

Assignment of line-side power components to Smart Line Modules in booksize format

Suitable line-side power components are assigned depending on the power rating of the Smart Line Module.

The tables below list recommended components.

Further information about the main contactors, switch disconnectors, fuses and circuit-breakers specified in the tables can be found in Catalogs LV 1, LV 1T and ET B1. ¹⁾

Rated infeed power kW (HP)	Assignment to Smart Line Module Type 6SL3...	Main contactor Type	Circuit-breaker Order No.	Main switch Order No.	Fuse switch disconnecter Order No.
Line voltage 380 V to 480 V 3 AC					
5 (5)	130-6AE15-0AA0 130-6AE15-0AB0 131-6AE15-0AA0	3RT1023-...	3RV1031-4BA10	3LD2003-0TK51	3NP4010-0CH01
10 (10)	130-6AE21-0AA0 130-6AE21-0AB0 131-6AE21-0AA0	3RT1026-...	3RV1031-4FA10	3LD2203-0TK51	3NP4010-0CH01
16 (18)	130-6AE21-6AB0	3RT1035-...	3RV1031-4FA10	3LD2504-0TK51	3NP4010-0CH01
36 (40)	130-6AE23-6AB0	3RT1045-...	3RV1041-4LA10	3LD2704-0TK51	3NP4010-0CH01

Rated infeed power kW (HP)	Assignment to Smart Line Module Type 6SL3...	Switch disconnecter with fuse holders Order No.	NH fuse (gL/gG)		
			Order No.	Rated current A	Size
Line voltage 380 V to 480 V 3 AC					
5 (5)	130-6AE15-0AA0 130-6AE15-0AB0 131-6AE15-0AA0	3KL5030-1EB01	3NA3805	16	000
10 (10)	130-6AE21-0AA0 130-6AE21-0AB0 131-6AE21-0AA0	3KL5030-1EB01	3NA3814	35	000
16 (18)	130-6AE21-6AB0	3KL5030-1EB01	3NA3814	35	000
36 (40)	130-6AE23-6AB0	3KL5230-1EB01	3NA3824	80	000

1) Component selections are per IEC standards and not necessarily in accordance with UL or NEC requirements. For NEMA components please see North American Industrial Products Catalog and Speedfax Catalog.

Overview



The self-commutated feed/feedback units (with IGBTs in infeed and regenerative feedback directions) generate a regulated DC link voltage. This means that the connected Motor Modules are decoupled from the line voltage. Line voltage fluctuations within the permissible supply tolerances have no effect on the motor voltage. Active Line Modules are designed for connection to grounded-neutral (TN, TT) and non-grounded (IT) supply systems.

The DC link is pre-charged via integrated precharging resistors.

Design

The Active Line Modules in booksize format feature the following interfaces as standard:

- 1 power connection via screw-type terminals
- 1 connection for the 24 V DC electronics power supply via the 24 V terminal adapter included in the scope of supply
- 1 DC link connection via integrated DC link busbars
- 3 DRIVE-CLiQ sockets
- 2 PE (protective earth) connections

The status of the Active Line Modules is indicated via two multi-color LEDs.

On the 100 mm (3.94 in) wide Active Line Module, the shield for the power supply cable can be connected to the integrated shield connection plate via a shield connection terminal or tube clip, e.g., Weidmüller type KLBÜ CO 4. The shield connection terminal must not be used for strain relief. Shield connection kits are available for the 150 mm (5.91 in), 200 mm (7.87 in) and 300 mm (11.81 in) wide modules.

The signal cable shield can be connected to the Line Module by means of a shield connection terminal, e.g. Weidmüller type KLBÜ 3-8 SC.

The scope of supply of the Active Line Modules includes:

- DRIVE-CLiQ cable for connection to the Control Unit for drive control on the immediate left
- DRIVE-CLiQ cable (length depends on module width) to connect Active Line Module to adjacent Motor Module
- Jumper for connecting the 24 V DC busbar to the adjacent Motor Module
- 24 V terminal adapter (X24)
- Connector X21 for digital inputs

Integration

The Active Line Module communicates with the CU 320 Control Unit via DRIVE-CLiQ and receives its control information via this route.

2

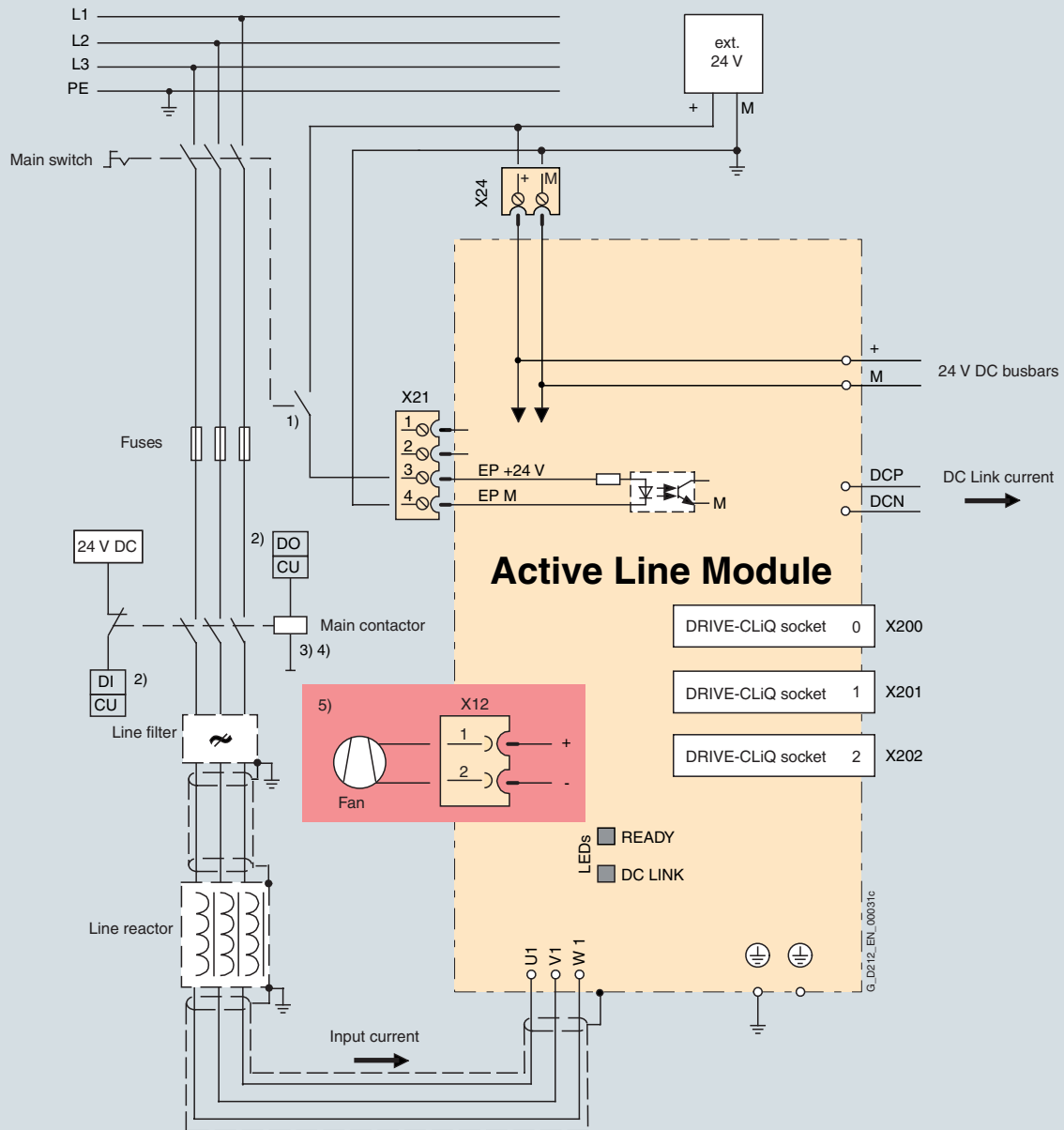

- 1) Leading NC contact $t > 10$ ms, 24 V DC and ground must be connected for operation.
- 2) Digital Input (DI) or digital output (DO) controlled by the Control Unit.
- 3) No additional load permitted downstream of the main contactor.
- 4) The current capacity of the digital output (DO) must be taken into account; an output interface element may have to be used.
- 5) Fan insert for Active Line Module 80 kW and 120 kW. The fan insert is supplied with the Active Line Module.

Connection example of Active Line Module in booksize format

Technical data

General technical data

Electrical data	
Line connection voltage (up to 2000 m (6563 ft) above sea level)	380 V to 480 V 3 AC $\pm 10\%$ ($-15\% < 1 \text{ min}$)
Power frequency	47 Hz to 63 Hz
Power factor	
• Active mode	
- Fundamental Power Factor	1.0 (factory setting), can be altered by input of a reactive current setpoint
- Total (λ)	1.0 (factory setting)
• Smart mode	
- Fundamental mode	> 0.96
- Overall	0.65 to 0.90
Overtoltage category	Class III to EN 60664-1
DC link voltage V_d	In "Active Mode" the DC link voltage is regulated and can be adjusted as a voltage decoupled from the line voltage. In "Smart Mode" the DC link voltage is regulated in proportion to the line voltage to the mean rectified line voltage value. Factory setting for DC link voltage: 380 V to 400 V 3 AC: 600 V (Active Mode) 400 V to 415 V 3 AC: 625 V (Active Mode) 416 V to 480 V 3 AC: 1.35 x line voltage (Smart Mode)
Electronics power supply	24 V DC $-15\%/+20\%$
Radio interference suppression	
• Standard	No radio interference suppression
• With line filter	Class A1 to EN 55011 and Category C2 to EN 61800-3
Ambient conditions	
Type of cooling	Forced air cooling through a built-in fan
Permissible ambient and coolant temperature (air) during operation for line-side components, Line Modules and Motor Modules	0 °C to + 40 °C (32° F to +104 °F) without derating, > 40°C to + 55 °C (> 104 °F to +131 °F) see derating characteristics
Site altitude	Up to 1000 m (1328 ft) above sea level without derating, > 1000 m (1328 ft) to 4000 m (13126 ft) above sea level see derating characteristics
Certificates	
Conformity	CE (low-voltage and EMC Directives)
Approvals	cULus (File No.: E192450)

SINAMICS S120

Line Modules and line-side components

Active Line Modules in booksize format

Technical data (continued)

Line voltage 380 V to 480 V 3 AC		Active Line Modules in booksize format				
Internal air cooling		6SL3130-7TE21-6AA1	6SL3130-7TE23-6AA1	6SL3130-7TE25-5AA2	6SL3130-7TE28-0AA1	6SL3130-7TE31-2AA1
Internal air cooling with varnished modules		6SL3130-7TE21-6AB0	6SL3130-7TE23-6AB0	6SL3130-7TE25-5AB0	6SL3130-7TE28-0AB0	6SL3130-7TE31-2AB0
External air cooling		6SL3131-7TE21-6AA0	6SL3131-7TE23-6AA0	6SL3131-7TE25-5AA0	6SL3131-7TE28-0AA0	6SL3131-7TE31-2AA0
Rated feed/feedback power P_{rated} with 380 V 3 AC with 460 V 3 AC ³⁾	kW (HP)	16 (18)	36 (40)	55 (60)	80 (100)	120 (150)
I/RF power for S6 duty (40%) P_{S6}	kW	21	47	71	106	158
Max. I/RF power P_{max}	kW	35	70	91	131	175
DC link current at 600 V DC	A	27	60	92	134	200
DC link current for S6 duty (40%)	A	35	79	121	176	244
Max. DC link current	A	59	117	152	218	292
Rated input current with 380 V 3 AC	A	26	58	88	128	192
Input current for S6 duty (40%)	A	35	79	121	176	244
Max. input current	A	59	117	152	195	292
Max. current requirement 24 V DC electronics power supply	A	1.1	1.5	1.9	2.0	2.5
24 V DC busbar current capacity	A	20	20	20	20	20
DC link capacitance	μF	710	1410	1880	2820	3995
Max. DC link capacitance of drive group	μF	20000	20000	20000	20000	20000
DC link busbar current capacity	A	100	100	200	200	200
Efficiency η		0.98	0.98	0.98	0.98	0.98
Power loss ¹⁾ with internal air cooling	kW	0.26	0.63	0.90	1.35	2.20
Power loss ¹⁾ with external air cooling int./ext.	kW	0.06/0.2	0.135/0.495	0.2/0.7	0.305/1.045	0.49/1.71
Cooling air requirement	m ³ /s (ft ³ /s)	0.016 (0.565)	0.031 (1.095)	0.044 (1.554)	0.144 (5.085)	0.144 (5.085)
Sound pressure level	dB(A)	< 60	< 65	< 60	< 75	< 75
Power connection U1, V1, W1		Screw-type terminals 2.5 mm ² to 10 mm ² (X1)	M6 screw studs for ring terminal ends 2.5 mm ² to 50 mm ² (X1)	M8 screw studs for ring terminal ends 2.5 mm ² to 95 mm ² , 2 x 35 mm ² (X1)	M8 screw studs for ring terminal ends 2.5 mm ² to 120 mm ² , 2 x 50 mm ² (X1)	M8 screw studs for ring terminal ends 2.5 mm ² to 120 mm ² , 2 x 50 mm ² (X1)
Shield connection		Integrated into the connector	see Accessories	see Accessories	see Accessories	see Accessories
PE connection		On housing with M5 screw	On housing with M6 screw	On housing with M6 screw	On housing with M8 screw	On housing with M8 screw
Max. cable length (total of all motor power cables and DC link)	m (ft)	350 (1150) shielded 560 (1840) unshielded	350 (1150) shielded 560 (1840) unshielded	350 (1150) shielded 560 (1840) unshielded	350 (1150) shielded 560 (1840) unshielded	350 (1150) shielded 560 (1840) unshielded
Degree of protection		IP20	IP20	IP20	IP20	IP20
Width	mm (inch)	100 (3.94)	150 (5.91)	200 (7.87)	300 (11.81)	300 (11.81)
Height	mm (inch)	380 (14.96)	380 (14.96)	380 (14.96)	380 (14.96) with fan ²⁾ : 629 (24.8)	380 (14.96) with fan ²⁾ : 629 (24.8)
Depth with internal air cooling	mm (inch)	270 (10.63)	270 (10.63)	270 (10.63)	270 (10.63)	270 (10.63)
Depth with external air cooling on/behind mounting surface	mm (inch)	226/66.5 (8.9/2.6)	226/71 (8.9/2.8)	226/92 (8.9/3.6)	226/82 (8.9/3.2)	226/82 (8.9/3.2)
Approx. weight with internal air cooling	kg (lb)	7 (15)	10.3 (23)	17 (38)	23 (51)	23 (51)
Approx. weight with external air cooling	kg (lb)	8.8 (19)	13.8 (30)	18.5 (41)	27.7 (61)	30.7 (68)

¹⁾ Power loss of Active Line Module at rated output without losses of 24 V DC electronics power supply.

²⁾ The fan is supplied with the Active Line Module and must be installed before the Active Line Module is commissioned.

³⁾ Nominal HP ratings are provided for ease of assigning components only. The Line Module outputs are dependent on the Motor Module loading and are to be dimensioned accordingly.

Selection and ordering data

Rated infeed power kW (HP)	Active Line Module in booksize format		
	Internal air cooling	Internal air cooling with varnished modules	External air cooling
	Order No.	Order No.	Order No.
Line voltage 380 V to 480 V 3 AC			
16 (18)	6SL3130-7TE21-6AA1	6SL3130-7TE21-6AB0	6SL3131-7TE21-6AA0
36 (40)	6SL3130-7TE23-6AA1	6SL3130-7TE23-6AB0	6SL3131-7TE23-6AA0
55 (60)	6SL3130-7TE25-5AA2	6SL3130-7TE25-5AB0	6SL3131-7TE25-5AA0
80 (100)	6SL3130-7TE28-0AA1	6SL3130-7TE28-0AB0	6SL3131-7TE28-0AA0
120 (150)	6SL3130-7TE31-2AA1	6SL3130-7TE31-2AB0	6SL3131-7TE31-2AA0

Accessories

Description	Order No.
Shield connection kit for Line/Motor Modules in booksize format <ul style="list-style-type: none"> • 150 mm (5.91 in) wide for internal air cooling • 150 mm (5.91 in) wide for external air cooling • 200 mm (7.87 in) wide for internal air cooling • 200 mm (7.87 in) wide for external air cooling • 300 mm (11.81 in) wide 	6SL3162-1AF00-0AA1 6SL3162-1AF00-0BA0 6SL3162-1AH01-0AA0 6SL3162-1AH01-0BA0 6SL3162-1AH00-0AA0
DC link supply adapter for direct infeed of DC link voltage <ul style="list-style-type: none"> • Screw-type terminals 0.5 mm² to 10 mm² for Line Modules and Motor Modules in booksize format with a width of 50 mm (1.97 in) or 100 mm (3.94 in) • Screw-type terminals 35 mm² to 95 mm² for Line Modules and Motor Modules in booksize format with a width of 150 mm (5.91 in), 200 mm (7.87 in) and 300 mm (11.81 in) 	6SL3162-2BD00-0AA0 6SL3162-2BM00-0AA0
DC link adapters (2x) for multi-tier configuration Screw-type terminals 35 mm ² to 95 mm ² for all Line Modules and Motor Modules in booksize format	6SL3162-2BM01-0AA0
24 V terminal adapter for all Line Modules and Motor Modules in booksize format	6SL3162-2AA00-0AA0
24 V jumper for connection of the 24 V busbars (for booksize format)	6SL3162-2AA01-0AA0
Warning signs in foreign languages This set of foreign language warning signs can be placed on top of the standard German or English signs. One sign in each of the following languages is provided in each set: Simplified Chinese, Danish, Dutch, Finnish, French, Greek, Italian, Japanese, Korean, Portuguese, Spanish and Swedish.	6SL3166-3AB00-0AA0

SINAMICS S120

Line Modules and line-side components

Active Line Modules in booksize format

2

Characteristics

Overload capability

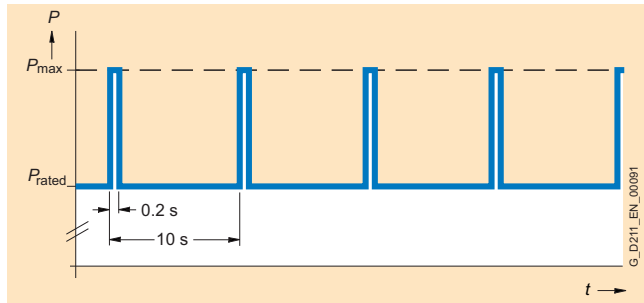

Load cycle with previous load

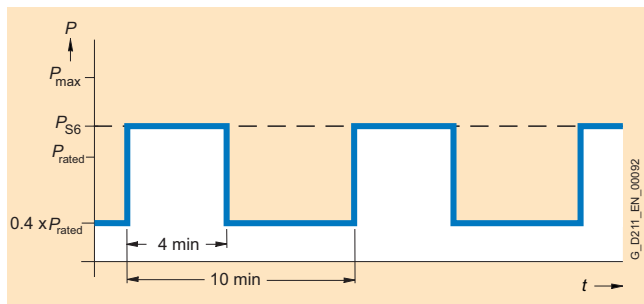

S6 load cycle with previous load

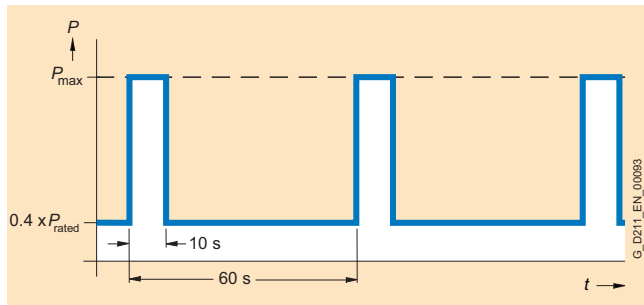

S6 load cycle with previous load

Derating characteristics

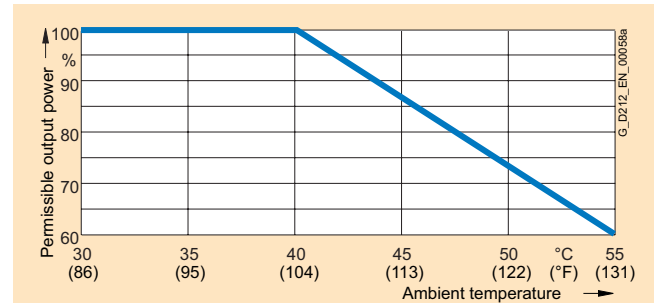

Output rating dependent on ambient temperature

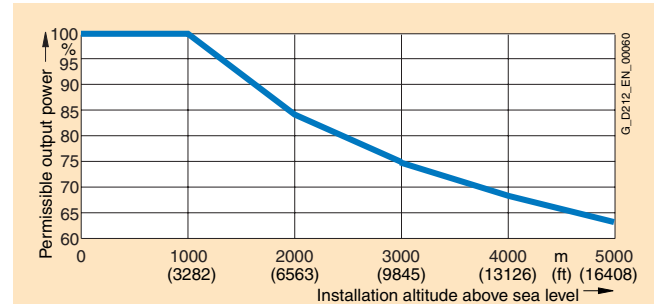

Output rating dependent on installation altitude

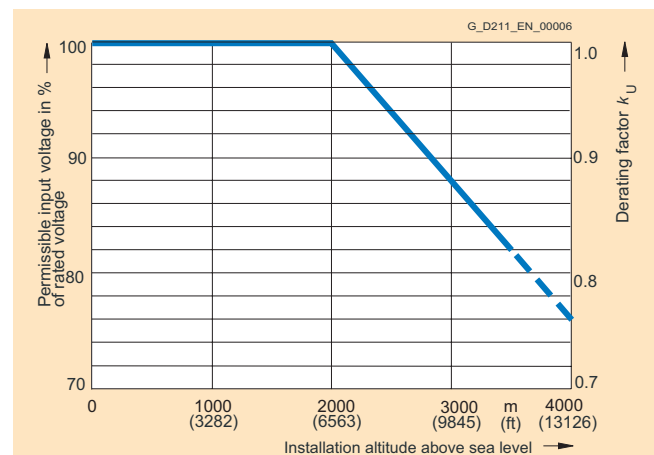

Voltage derating dependent on installation altitude

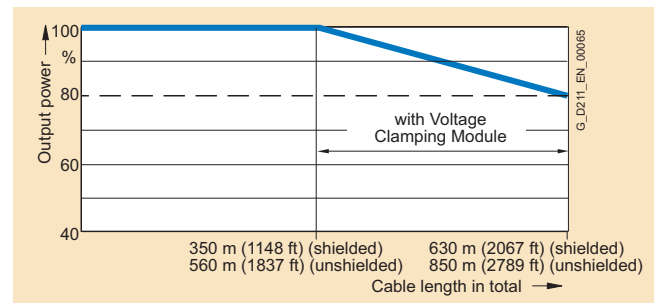

Output rating dependent on total cable length

SINAMICS S120

Line Modules and line-side components

Active Line Modules in booksize format
Line reactors

Overview



Active Line Modules cannot operate without the specified line reactors. The use of other makes of line reactor can lead to malfunctions or irreparable damage to equipment.

Selection and ordering data

Rated input power of the Active Line Module kW (HP)	Suitable for Active Line Module	Line reactor Order No.
Line voltage 380 V to 480 V 3 AC		
16 (18)	6SL3130-7TE21-6AA1 6SL3130-7TE21-6AB0 6SL3131-7TE21-6AA0	6SN1111-0AA00-0BA1
36 (40)	6SL3130-7TE23-6AA1 6SL3130-7TE23-6AB0 6SL3131-7TE23-6AA0	6SN1111-0AA00-0CA1
55 (60)	6SL3130-7TE25-5AA2 6SL3130-7TE25-5AB0 6SL3131-7TE25-5AA0	6SN1111-0AA00-0DA1
80 (100)	6SL3130-7TE28-0AA1 6SL3130-7TE28-0AB0 6SL3131-7TE28-0AA0	6SN1111-0AA00-1EA0
120 (150)	6SL3130-7TE31-2AA1 6SL3130-7TE31-2AB0 6SL3131-7TE31-2AA0	6SL3000-0DE31-2BA0

Technical data

Line voltage 380 V to 480 V 3 AC		Line reactor 6SN1111-0AA00-0BA1	6SN1111-0AA00-0CA1	6SN1111-0AA00-0DA1	6SN1111-0AA00-1EA0	6SL3000-0DE31-2BA0
Rated current	A	30	67	103	150	225
Power loss	kW	0.17	0.25	0.35	0.45	0.59
Line/load connection 1U1, 1V1, 1W1 / 1U2, 1V2, 1W2		16 mm ² screw-type terminals	35 mm ² screw-type terminals	70 mm ² screw-type terminals	M10 connecting lugs	M10 connecting lugs
PE connection		16 mm ² screw-type terminals	35 mm ² screw-type terminals	70 mm ² screw-type terminals	M10 connecting lugs	M10 connecting lugs
Degree of protection		IP20	IP20	IP20	IP00	IP00
Width	mm (inch)	150 (5.91)	150 (5.91)	150 (5.91)	225 (8.86)	225 (8.86)
Height	mm (inch)	330 (12.99)	330 (12.99)	330 (12.99)	380 (14.96)	490 (19.29)
Depth	mm (inch)	145 (5.71)	230 (9.05)	280 (11.02)	220 (8.66)	250 (9.84)
Weight, approx.	kg (lb)	8.5 (19)	13 (29)	18 (40)	40 (88)	64 (141)
Suitable for Active Line Module	Type	6SL3130-7TE21-6AA1 6SL3130-7TE21-6AB0 6SL3131-7TE21-6AA0	6SL3130-7TE23-6AA1 6SL3130-7TE23-6AB0 6SL3131-7TE23-6AA0	6SL3130-7TE25-5AA2 6SL3130-7TE25-5AB0 6SL3131-7TE25-5AA0	6SL3130-7TE28-0AA1 6SL3130-7TE28-0AB0 6SL3131-7TE28-0AA0	6SL3130-7TE31-2AA1 6SL3130-7TE31-2AB0 6SL3131-7TE31-2AA0

Overview

In plants which have strict EMC requirements, line filters work together with line reactors to restrict the conducted interference emanating from the Power Modules to the limit values of Class A1 as defined in EN 55011 and Category C2 as defined in EN 61800-3. Line filters are suited only for direct connection to TN (grounded) systems.

Optional line filter ranges that are coordinated with the power range are available for the SINAMICS S120 drive system:

- Wideband Line Filters
- Basic Line Filters

These line filters differ with regard to the frequency range in which they reduce the conducted emissions.

Note: According to product standard IEC 61800-3 or EN 50370-1, RI suppression commensurate with the relevant operating conditions must be provided and is a legal requirement in the EU (EMC Directive). Line filters and line reactors are required for this purpose. The use of filters of other makes can lead to limit value violations, resonance, overvoltages and irreparable damage to motors or other equipment. The machine manufacturer must provide verification that the machinery to be operated with the drive products and the installed suppression elements, e.g. line filters, are CE/EMC-compliant before the machines are approved for delivery.

Active Line Modules in booksize format Wideband Line Filters (in line filter package)

Overview



The damping characteristics of Wideband Line Filters for Active Line Modules not only conform with the requirements of EMC standards for the frequency range of 150 kHz to 30 MHz but also include low frequencies of 2 kHz and above. As a result, these line filters have an extended functional range, allowing a certain independence with respect to the machine installation location in cases where the line properties are generally unknown (e.g., line impedance).

Selection and ordering data

Line filters for Active Line Modules in booksize format are available only in combination with the relevant line reactor as a line filter package. The order number for the line filter package includes the Wideband Line Filter and the line reactor.

Rated input power of the Active Line Module kW (HP)	Suitable for Active Line Module	Line filter package (Wideband Line Filter and line reactor) Order No.
Line voltage 380 V to 480 V 3 AC		
16 (18)	6SL3130-7TE21-6AA1 6SL3130-7TE21-6AB0 6SL3131-7TE21-6AA0	6SL3000-0FE21-6AA0
36 (40)	6SL3130-7TE23-6AA1 6SL3130-7TE23-6AB0 6SL3131-7TE23-6AA0	6SL3000-0FE23-6AA0
55 (60)	6SL3130-7TE25-5AA2 6SL3130-7TE25-5AB0 6SL3131-7TE25-5AA0	6SL3000-0FE25-5AA0
80 (100)	6SL3130-7TE28-0AA1 6SL3130-7TE28-0AB0 6SL3131-7TE28-0AA0	6SL3000-0FE28-0AA0
120 (150)	6SL3130-7TE31-2AA1 6SL3130-7TE31-2AB0 6SL3131-7TE31-2AA0	6SL3000-0FE31-2AA1

SINAMICS S120

Line Modules and line-side components

Active Line Modules in booksize format
Wideband Line Filters (in line filter package)

Technical data

Line voltage 380 V to 480 V 3 AC		Wideband Line Filter (included in each line filter package)				
		6SL3000-0FE21-6AA0	6SL3000-0FE23-6AA0	6SL3000-0FE25-5AA0	6SL3000-0FE28-0AA0	6SL3000-0FE31-2AA1
Rated current	A	30	67	103	150	225
Power loss	kW	0.07	0.09	0.11	0.15	0.20
Line/load connection L1, L2, L3 / U, V, W		10 mm ² screw-type terminals	50 mm ² screw-type terminals	50 mm ² screw-type terminals	95 mm ² screw-type terminals	M10 connecting lugs
PE connection		On housing with M5 bolt	On housing with M8 bolt	On housing with M8 bolt	On housing with M8 bolt	On housing with M8 bolt
Degree of protection		IP20	IP20	IP20	IP20	IP00
Width	mm (inch)	130 (5.12)	130 (5.12)	130 (5.12)	200 (7.87)	300 (11.81)
Height	mm (inch)	480 (18.9)	480 (18.9)	480 (18.9)	480 (18.9)	480 (18.9)
Depth	mm (inch)	150 (5.91)	245 (9.65)	260 (10.24)	260 (10.24)	260 (10.24)
Weight, approx.	kg (lb)	9 (20)	16 (35)	19 (42)	22 (49)	32 (71)
Suitable for Active Line Module	Type	6SL3130-7TE21-6AA1 6SL3130-7TE21-6AB0 6SL3131-7TE21-6AA0	6SL3130-7TE23-6AA1 6SL3130-7TE23-6AB0 6SL3131-7TE23-6AA0	6SL3130-7TE25-5AA2 6SL3130-7TE25-5AB0 6SL3131-7TE25-5AA0	6SL3130-7TE28-0AA1 6SL3130-7TE28-0AB0 6SL3131-7TE28-0AA0	6SL3130-7TE31-2AA1 6SL3130-7TE31-2AB0 6SL3131-7TE31-2AA0

Accessories



Line filter package assembled with an adapter set

The adapter sets for units in booksize format are designed for very compact mounting. They enable line filters and line reactors to be installed compactly one above the other in the control cabinet.

Active Line Module power output kW (HP)	Line filter package	Adapter set Order No.
16 (18)	6SL3000-0FE21-6AA0	6SL3060-1FE21-6AA0
36 (40)	6SL3000-0FE23-6AA0	6SN1162-0GA00-0CA0

SINAMICS S120

Line Modules and line-side components

Active Line Modules in booksize format Basic Line Filters

Overview



Basic Line Filters are used on machines on which conducted interference emissions in the frequency range between 150 kHz and 30 MHz need to be damped in accordance with the requirements of CE-EMC legislation.

Selection and ordering data

Rated input power of the Active Line Module kW (HP)	Suitable for Active Line Module	Basic Line Filter Order No.
Line voltage 380 V to 480 V 3 AC		
16 (18)	6SL3130-7TE21-6AA1 6SL3130-7TE21-6AB0 6SL3131-7TE21-6AA0	6SL3000-0BE21-6DA0
36 (40)	6SL3130-7TE23-6AA1 6SL3130-7TE23-6AB0 6SL3131-7TE23-6AA0	6SL3000-0BE23-6DA0
55 (60)	6SL3130-7TE25-5AA2 6SL3130-7TE25-5AB0 6SL3131-7TE25-5AA0	6SL3000-0BE25-5DA0

Further information

You must follow the instructions in the Equipment Manual when using Basic Line Filters in conjunction with Active Line Modules on your machine: SINAMICS S120 booksize power units.

Technical data

Line voltage 380 V to 480 V 3 AC	Basic Line Filters			
		6SL3000-0BE21-6DA0	6SL3000-0BE23-6DA0	6SL3000-0BE25-5DA0
Rated current	A	36	65	105
Power loss	kW	0.006	0.010	0.015
Line/load connection L1, L2, L3 / U, V, W		10 mm ² screw-type terminals	35 mm ² screw-type terminals	50 mm ² screw-type terminals
PE connection		On housing with M6 bolt	On housing with M6 bolt	On housing with M8 bolt
Degree of protection		IP20	IP20	IP20
Width	mm (inch)	50 (1.97)	75 (2.95)	100 (3.94)
Height	mm (inch)	420 (16.54)	420 (16.54)	420 (16.54)
Depth	mm (inch)	226 (8.9)	226 (8.9)	226 (8.9)
Weight, approx.	kg (lb)	5 (11)	6.5 (14)	11.5 (25)
Suitable for Active Line Module	Type	6SL3130-7TE21-6AA1 6SL3130-7TE21-6AB0 6SL3131-7TE21-6AA0	6SL3130-7TE23-6AA1 6SL3130-7TE23-6AB0 6SL3131-7TE23-6AA0	6SL3130-7TE25-5AA2 6SL3130-7TE25-5AB0 6SL3131-7TE25-5AA0

SINAMICS S120

Line Modules and line-side components

Active Line Modules in booksize format
Recommended line-side components

Overview

Assignment of line-side power components to Active Line Modules in booksize format

Suitable line-side power components are assigned depending on the power rating of the Active Line Modules.

The tables below list recommended components.

Further information about the main contactors, switch disconnectors, fuses and circuit-breakers specified in the tables can be found in Catalogs LV 1 and LV 1T.¹⁾

Rated infeed power kW (HP)	Assignment to Active Line Module Type 6SL3...	Main contactor Type	Output interface for main contactor (relay coupler) Order No.	Main switch (switch disconnector) Order No.	Leading auxiliary circuit switch for main switch Order No.
Line voltage 380 V to 480 V 3 AC					
16 (18)	130-7TE21-6AA1 130-7TE21-6AB0 131-7TE21-6AA0	3RT1035-...	3TX7004-1LB00	3LD2504-0TK51	3LD9200-5B
36 (40)	130-7TE23-6AA1 130-7TE23-6AB0 131-7TE23-6AA0	3RT1045-...	3TX7004-1LB00	3LD2704-0TK51	3LD9200-5B
55 (60)	130-7TE25-5AA2 130-7TE25-5AB0 131-7TE25-5AA0	3RT1054-...	3TX7004-1LB00	3KA5330-1EE01	3KX3552-3EA01
80 (100)	130-7TE28-0AA1 130-7TE28-0AB0 131-7TE28-0AA0	3RT1056-...	3TX7004-1LB00	3KA5330-1EE01	3KX3552-3EA01
120 (150)	130-7TE31-2AA1 130-7TE31-2AB0 131-7TE31-2AA0	3RT1065-...	3TX7004-1LB00	3KA5730-1EE01	3KX3552-3EA01
Rated infeed power kW (HP)	Assignment to Active Line Module Type 6SL3...	Circuit-breaker Order No.	Fuse switch disconnector Order No.	Switch disconnector with fuse holders Order No.	Leading auxiliary switch for switch disconnector with fuse holders Order No.
Line voltage 380 V to 480 V 3 AC					
16 (18)	130-7TE21-6AA1 130-7TE21-6AB0 131-7TE21-6AA0	3RV1031-4FA10	3NP4010-0CH01	3KL5030-1EB01	3KX3552-3EA01
36 (40)	130-7TE23-6AA1 130-7TE23-6AB0 131-7TE23-6AA0	3RV1041-4LA10	3NP4010-0CH01	3KL5230-1EB01	3KX3552-3EA01
55 (60)	130-7TE25-5AA2 130-7TE25-5AB0 131-7TE25-5AA0	3VL2712-3DC33-0AA0	3NP4270-0CA01	3KL5530-1EB01	3KX3552-3EA01
80 (100)	130-7TE28-0AA1 130-7TE28-0AB0 131-7TE28-0AA0	3VL2716-3DC33-0AA0	3NP4270-0CA01	3KL5530-1EB01	3KX3552-3EA01
120 (150)	130-7TE31-2AA1 130-7TE31-2AB0 131-7TE31-2AA0	3VL3725-3DC36-0AA0	3NP5360-0CA00	3KL5730-1EB01	3KX3552-3EA01

1) Component selections are per IEC standards and not necessarily in accordance with UL or NEC requirements. For NEMA components please see North American Industrial Products Catalog and Speedfax Catalog.

SINAMICS S120

Line Modules and line-side components

Active Line Modules in booksize format Recommended line-side components

Overview (continued)

Rated infeed power	Assignment to Active Line Module	NEOZED fuse (gL/gG)			DIAZED fuse (gL/gG)			NH fuse (gL/gG)			UL/CSA fuse, Class J Available from: Ferraz Shawmut http://www.ferrazshawmut.com		
		Order No.	Rated current	Size	Order No.	Rated current	Size	Order No.	Rated current	Size	Reference No.	Rated current	Size
kW (HP)	Type 6SL3...												
Line voltage 380 V to 480 V 3 AC													
16 (18)	130-7TE21-6AA1 130-7TE21-6AB0 131-7TE21-6AA0	5SE2335	35 A	D02	5SB411	35 A	DIII	3NA3814	35 A	000	AJT35	35 A	27 × 60
36 (40)	130-7TE23-6AA1 130-7TE23-6AB0 131-7TE23-6AA0	–	–	–	5SC211	80 A	DIVH	3NA3824	80 A	000	AJT80	80 A	29 × 117
55 (60)	130-7TE25-5AA2 130-7TE25-5AB0 131-7TE25-5AA0	–	–	–	–	–	–	3NA3132	125 A	1	AJT125	125 A	41 × 146
80 (100)	130-7TE28-0AA1 130-7TE28-0AB0 131-7TE28-0AA0	–	–	–	–	–	–	3NA3136	160 A	1	AJT175	175 A	41 × 146
120 (150)	130-7TE31-2AA1 130-7TE31-2AB0 131-7TE31-2AA0	–	–	–	–	–	–	3NA3144	250 A	1	AJT250	250 A	54 × 181

Overview

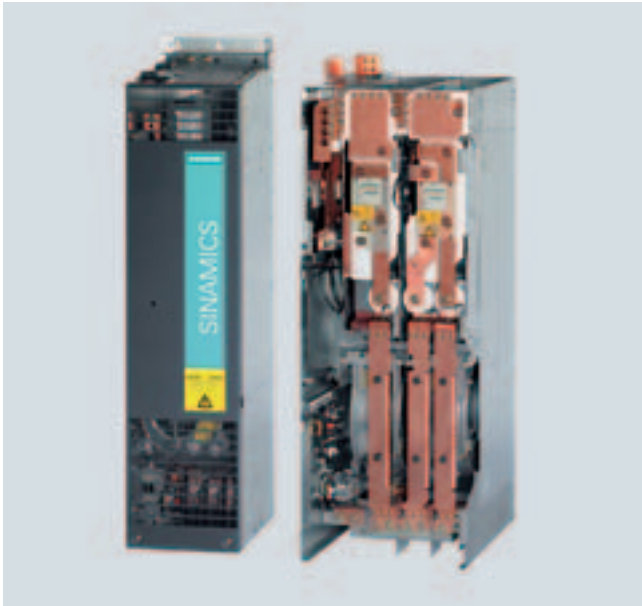

The self-commutated feed/feedback units (with IGBTs in infeed and regenerative feedback directions) generate a regulated DC link voltage. This means that the connected Motor Modules are decoupled from the line voltage. Line voltage fluctuations within the permissible supply tolerances have no effect on the motor voltage.

If required, the Active Line Modules can also provide reactive power compensation.

Active Line Modules are designed for connection to grounded-neutral (TN, TT) and non-grounded (IT) supply systems.

Design

The Active Line Modules in chassis format feature the following interfaces as standard:

- 1 power connection
- 1 connection for the 24 V DC electronics power supply
- 1 DC link connection
- 3 DRIVE-CLiQ sockets
- 2 PE (protective earth) connections

The status of the Active Line Modules is indicated via two multi-color LEDs.

The scope of supply of the Active Line Modules includes:

- Types FX and GX:
 - 0.60 m (1.97 ft) DRIVE-CLiQ cable for connection to the CU320 or SIMOTION D Control Unit
- Types HX and JX
 - 0.35 m (1.15 ft) DRIVE-CLiQ cable for connection to the CU320 or SIMOTION D Control Unit
 - 2.10 m (6.89 ft) DRIVE-CLiQ cable for connection to the first Motor Module

Selection and ordering data

Infeed power kW (HP)	Active Line Modules in chassis format Order No.
Line voltage 380 V to 480 V 3 AC	
132 (200)	6SL3330-7TE32-1AA0
160 (225)	6SL3330-7TE32-6AA0
235 (350)	6SL3330-7TE33-8AA0
300 (450)	6SL3330-7TE35-0AA0
380 (550)	6SL3330-7TE36-1AA0
500 (700)	6SL3330-7TE38-4AA0
630 (800)	6SL3330-7TE41-0AA0
900 (1150)	6SL3330-7TE41-4AA0
Line voltage 660 V to 690 V 3 AC	
560	6SL3330-7TH35-8AA0
800	6SL3330-7TH37-4AA0
1100	6SL3330-7TH41-0AA0
1400	6SL3330-7TH41-3AA0

Warning signs in foreign languages

Warning signs in other languages can be placed on top of the standard warning signs in German or English.

The following signs are supplied with chassis format units: Chinese, Danish, Finnish, French, Greek, Italian, Japanese, Korean, Dutch, Polish, Portuguese, Russian, Swedish, Spanish, Czech and Turkish.

SINAMICS S120

Line Modules and line-side components

Active Line Modules in chassis format

Integration

The Active Line Module communicates with the CU320 or SIMOTION D Control Unit via DRIVE-CLiQ.

2

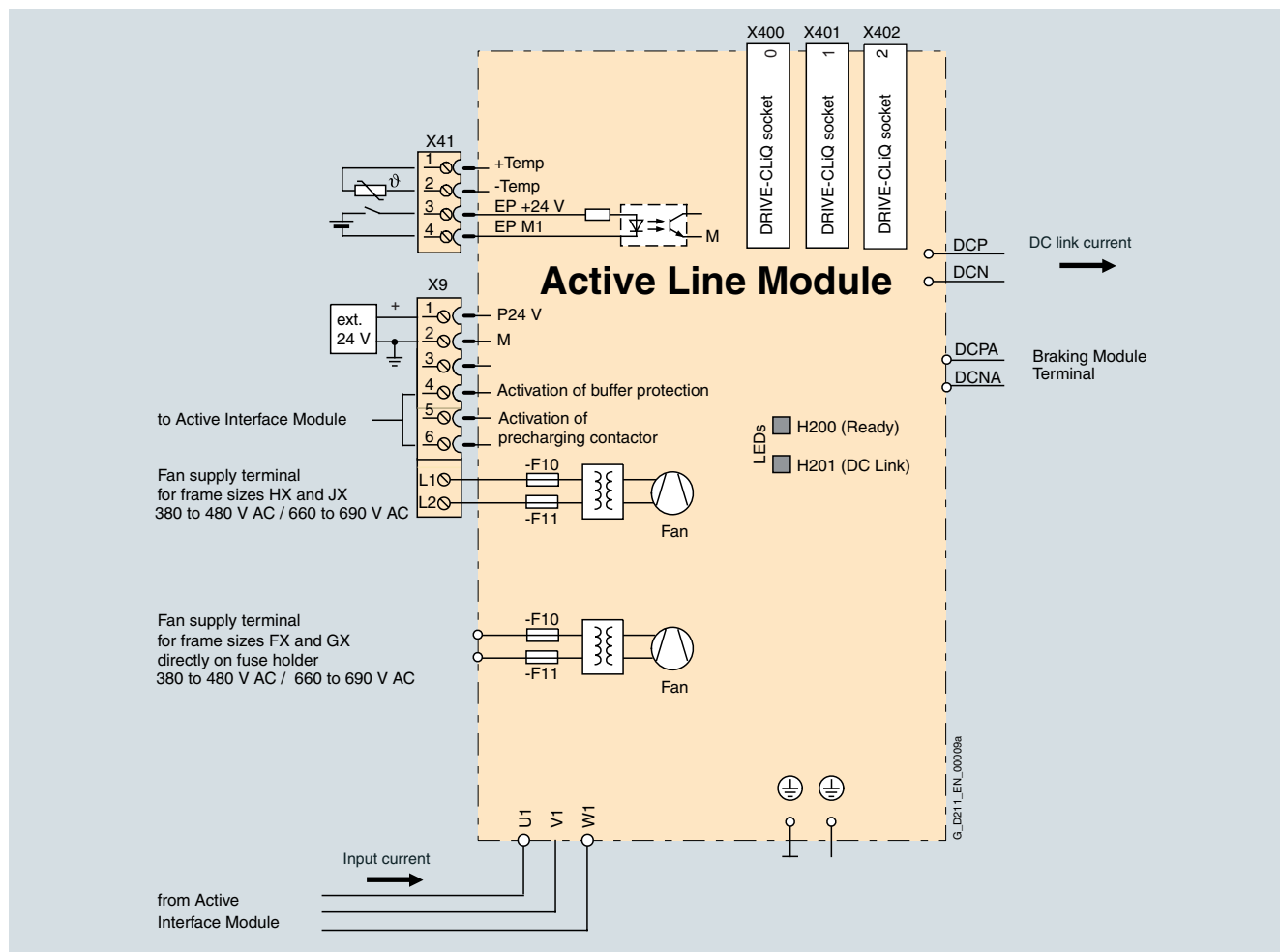

Connection example of Active Line Module in chassis format

Technical data

General technical data

Electrical data	
Line connection voltage (up to 2000 m (6563 ft) above sea level)	380 V to 480 V 3 AC ± 10% (– 15% < 1 min) or 660 V to 690 V 3 AC ± 10% (– 15% < 1 min)
Power frequency	47 Hz to 63 Hz
Power factor	
• Fundamental Power Factor	1.0 (factory setting), can be altered by input of a reactive current setpoint
• Total (λ)	1.0 (factory setting)
Overvoltage category	Class III to EN 60664-1
DC link voltage U_d	The DC link voltage is regulated and can be adjusted as a voltage decoupled from the line voltage. Factory setting for DC link voltage: 1.5 x line voltage
Electronics power supply	24 V DC – 15%/+ 20%
Radio interference suppression	
• Standard (with Active Interface Module)	Category C3 to EN 61800-3
• With line filter (and Active Interface Module)	Class A1 to EN 55011 and Category C2 to EN 61800-3
Ambient conditions	
Type of cooling	Forced air cooling through a built-in fan
Permissible ambient and coolant temperature (air) during operation for line-side components, Line Modules and Motor Modules	0 °C to + 40 °C (32 °F to +104 °F) without derating, > 40 °C to + 55 °C (> 104 °F to +131 °F) see derating characteristics
Installation altitude	Up to 2000 m (6563 ft) above sea level without derating, > 2000 m (6563 ft) to 4000 m (13126 ft) above sea level see derating characteristics
Certificates	
Conformity	CE (low-voltage and EMC Directives)
Approvals	cULus (File No.: E192450)

SINAMICS S120

Line Modules and line-side components

Active Line Modules in chassis format

Technical data (continued)

Line voltage 380 V to 480 V 3 AC		Active Line Modules in chassis format			
		6SL3330-7TE32-1AA0	6SL3330-7TE32-6AA0	6SL3330-7TE33-8AA0	6SL3330-7TE35-0AA0
Feed/feedback power P_{rated} with 400 V 3 AC with 460 V 3 AC ¹⁾	kW (HP)	132 (200)	160 (225)	235 (350)	300 (450)
Feed/feedback power for S6 duty (40%) P_{S6}	kW	On request	On request	On request	On request
Max. I/RF power P_{max}	kW	198	240	352.5	450
Rated DC link current $I_{\text{rated_DC}}$	A	235	291	425	549
DC link current $I_{\text{H_DC}}$	A	209	259	378	489
Max. DC link current $I_{\text{max_DC}}$	A	352	436	637	823
Input current for 3 AC 400 V	A	210	260	380	490
Input current for S6 duty (40%)	A	On request	On request	On request	On request
Max. input current	A	315	390	570	735
Max. current requirement 24 V DC electronics power supply	A	1.1	1.1	1.35	1.35
DC link capacitance	μF	4200	5200	7800	9600
Max. current requirements (fan supply) at 400 V 2 AC	A	0.63	2.0	2.6	2.6
Efficiency η		0.98	0.98	0.98	0.98
Power loss	kW	2.2	2.7	3.9	4.8
Cooling air requirement	m ³ /s (ft ³ /s)	0.17 (6)	0.23 (8.12)	0.36 (12.71)	0.36 (12.71)
Sound pressure level ²⁾ 50 Hz/60 Hz	dB(A)	74/76	75/77	76/78	76/78
Power connection U1, V1, W1		Flange connection with M10 screw, max. cross section 2 × 185 mm ²	Flange connection with M10 screw, max. cross section 2 × 185 mm ²	Flange connection with M10 screw, max. cross section 2 × 185 mm ²	Flange connection with M10 screw, max. cross section 2 × 185 mm ²
DC link connection DCP, DCN		Flange connection with M10 screw, max. cross section 2 × 185 mm ²	Flange connection with M10 screw, max. cross section 2 × 185 mm ²	Flange connection with M10 screw, max. cross section 2 × 185 mm ²	Flange connection with M10 screw, max. cross section 2 × 185 mm ²
PE connection		On housing with M10 screw, max. cross section PE1/GND 1 × 185 mm ² PE2/GND 2 × 185 mm ²	On housing with M10 screw, max. cross section PE1/GND 1 × 185 mm ² PE2/GND 2 × 185 mm ²	On housing with M10 screw, max. cross section PE1/GND 1 × 185 mm ² PE2/GND 2 × 185 mm ²	On housing with M10 screw, max. cross section PE1/GND 1 × 185 mm ² PE2/GND 2 × 185 mm ²
Max. cable length (total of all motor cables and DC link)	m (ft)	1000 (1328)	1000 (1328)	1000 (1328)	1000 (1328)
Degree of protection		IP20	IP20	IP20	IP20
Width	mm (inch)	326 (12.83)	326 (12.83)	326 (12.83)	326 (12.83)
Height	mm (inch)	1400 (55.12)	1400 (55.12)	1533 (60.35)	1533 (60.35)
Depth	mm (inch)	356 (14.02)	356 (14.02)	543 (21.38)	543 (21.38)
Size		FX	FX	GX	GX
Weight, approx.	kg (lb)	88 (194)	88 (194)	152 (335)	152 (335)

¹⁾ Nominal HP ratings are provided for ease of assigning components only. The Line Module outputs are dependent on the Motor Module loading and are to be dimensioned accordingly.

²⁾ Total sound pressure level of Active Interface Module and Active Line Module.

Technical data (continued)

Line voltage 380 V to 480 V 3 AC		Active Line Modules in chassis format			
		6SL3330-7TE36-1AA0	6SL3330-7TE38-4AA0	6SL3330-7TE41-0AA0	6SL3330-7TE41-4AA0
Feed/feedback power P_{rated} with 400 V 3 AC with 460 V 3 AC ¹⁾	kW (HP)	380 (550)	500 (700)	630 (800)	900 (1150)
Feed/feedback power for S6 duty (40%) P_{S6}	kW	On request	On request	On request	On request
Max. I/RF power P_{max}	kW	570	750	945	1350
Rated DC link current $I_{\text{rated_DC}}$	A	678	940	1103	1574
DC link current $I_{\text{H_DC}}$	A	603	837	982	1401
Max. DC link current $I_{\text{max_DC}}$	A	1017	1410	1654	2361
Input current for 3 AC 400 V	A	605	840	985	1405
Input current for S6 duty (40%)	A	On request	On request	On request	On request
Max. input current	A	907	1260	1477	2107
Max. current requirement 24 V DC electronics power supply	A	1.4	1.4	1.5	1.7
DC link capacitance	μF	12600	16800	18900	28800
Max. current requirements (fan supply) at 400 V 2 AC	A	5.2	5.2	7.8	7.8
Efficiency η		0.98	0.98	0.98	0.98
Power loss	kW	6.2	7.7	10.1	13.3
Cooling air requirement	m ³ /s (ft ³ /s)	0.78 (27.55)	0.78 (27.55)	1.08 (38.14)	1.08 (38.14)
Sound pressure level ²⁾ 50 Hz/60 Hz	dB(A)	78/80	78/80	78/80	78/80
Power connection U1, V1, W1		Flange connection with M12 screw, max. cross section 4 × 240 mm ²	Flange connection with M12 screw, max. cross section 4 × 240 mm ²	Flange connection with M12 screw, max. cross section 6 × 240 mm ²	Flange connection with M12 screw, max. cross section 6 × 240 mm ²
DC link connection DCP, DCN		Flange connection for busbar connection	Flange connection for busbar connection	Flange connection for busbar connection	Flange connection for busbar connection
PE connection		On housing with M12 screw, max. cross section PE1/GND 1 × 240 mm ² PE2/GND 2 × 240 mm ²	On housing with M12 screw, max. cross section PE1/GND 1 × 240 mm ² PE2/GND 2 × 240 mm ²	On housing with M12 screw, max. cross section PE1/GND 1 × 240 mm ² PE2/GND 2 × 240 mm ²	On housing with M12 screw, max. cross section PE1/GND 1 × 240 mm ² PE2/GND 2 × 240 mm ²
Max. cable length (total of all motor cables and DC link)	m (ft)	1500 (4921)	1500 (4921)	1500 (4921)	1500 (4921)
Degree of protection		IP00	IP00	IP00	IP00
Width	mm (inch)	503 (19.8)	503 (19.8)	704 (27.72)	704 (27.72)
Height	mm (inch)	1475 (58.07)	1475 (58.07)	1475 (58.07)	1475 (58.07)
Depth	mm (inch)	540 (21.26)	540 (21.26)	540 (21.26)	540 (21.26)
Size		HX	HX	JX	JX
Weight, approx.	kg (lb)	290 (640)	290 (640)	450 (992)	450 (992)

¹⁾ Nominal HP ratings are provided for ease of assigning components only. The Line Module outputs are dependent on the Motor Module loading and are to be dimensioned accordingly.

²⁾ Total sound pressure level of Active Interface Module and Active Line Module.

SINAMICS S120

Line Modules and line-side components

Active Line Modules in chassis format

Technical data (continued)

Line voltage 660 V to 690 V 3 AC		Active Line Modules in chassis format			
		6SL3330-7TH35-8AA0	6SL3330-7TH37-4AA0	6SL3330-7TH41-0AA0	6SL3330-7TH41-3AA0
Feed/feedback power P_{rated} with 690 V 3 AC	kW	560	800	1100	1400
Feed/feedback power for S6 duty (40%) P_{S6}	kW	On request	On request	On request	On request
Max. I/RF power P_{max}	kW	840	1200	1650	2100
Rated DC link current $I_{\text{rated_DC}}$	A	644	823	1148	1422
DC link current $I_{\text{H_DC}}$	A	573	732	1022	1266
Max. DC link current $I_{\text{max_DC}}$	A	966	1234	1722	2133
Input current for 3 AC 690 V	A	575	735	1025	1270
Input current for S6 duty (40%)	A	On request	On request	On request	On request
Max. input current	A	862	1102	1537	1905
Max. current requirement 24 V DC electronics power supply	A	1.4	1.5	1.7	1.7
DC link capacitance	μF	7400	11100	14400	19200
Max. current requirements (fan supply) at 690 V 2 AC	A	3	4.5	4.5	4.5
Efficiency η		0.98	0.98	0.98	0.988
Power loss	kW	6.8	10.2	13.6	16.5
Cooling air requirement	m^3/s (ft ³ /s)	0.78 (27.55)	1.1 (38.85)	1.1 (38.85)	1.1 (38.85)
Sound pressure level ¹⁾ 50 Hz/60 Hz	dB(A)	78/80	78/80	78/80	78/80
Power connection U1, V1, W1		Flange connection with M12 screw, max. cross section 4 × 240 mm ²	Flange connection with M12 screw, max. cross section 6 × 240 mm ²	Flange connection with M12 screw, max. cross section 6 × 240 mm ²	Flange connection with M12 screw, max. cross section 6 × 240 mm ²
DC link connection DCP, DCN		Flange connection for busbar connection	Flange connection for busbar connection	Flange connection for busbar connection	Flange connection for busbar connection
PE connection		On housing with M12 screw, max. cross section PE1/GND 1 × 240 mm ² PE2/GND 2 × 240 mm ²	On housing with M12 screw, max. cross section PE1/GND 1 × 240 mm ² PE2/GND 2 × 240 mm ²	On housing with M12 screw, max. cross section PE1/GND 1 × 240 mm ² PE2/GND 2 × 240 mm ²	On housing with M12 screw, max. cross section PE1/GND 1 × 240 mm ² PE2/GND 2 × 240 mm ²
Max. cable length (total of all motor cables and DC link)	m (ft)	1500 (4921)	1500 (4921)	1500 (4921)	1500 (4921)
Degree of protection		IP00	IP00	IP00	IP00
Width	mm (inch)	503 (19.8)	704 (27.72)	704 (27.72)	704 (27.72)
Height	mm (inch)	1475 (58.07)	1475 (58.07)	1475 (58.07)	1475 (58.07)
Depth	mm (inch)	540 (21.26)	540 (21.26)	540 (21.26)	540 (21.26)
Size		HX	JX	JX	JX
Weight, approx.	kg (lb)	290 (640)	450 (992)	450 (992)	450 (992)

¹⁾ Total sound pressure level of Active Interface Module and Active Line Module.

Characteristics

Overload capability

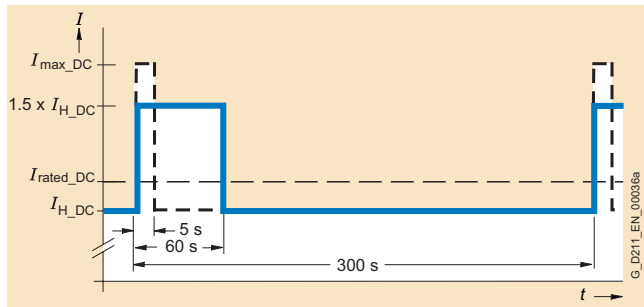

High overload

Derating characteristics

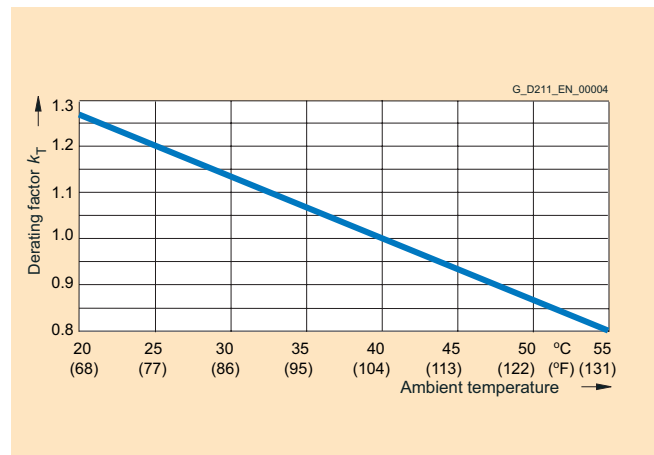

Current derating dependent on ambient temperature

Note: A derating factor k_T 1.0 is only possible in connection with the "current derating depending on the installation altitude". See also System description.

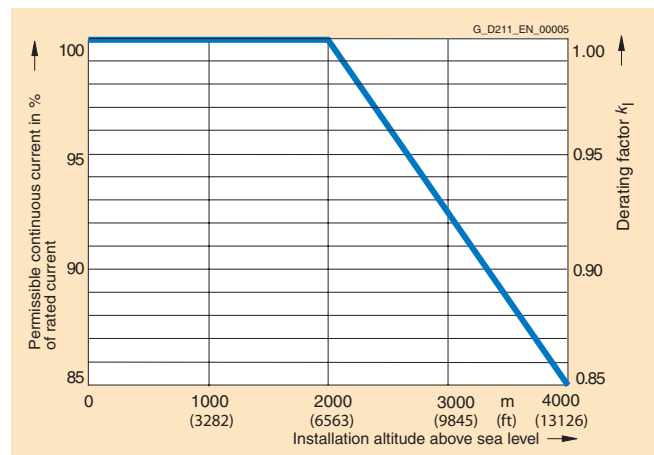

Current derating dependent on installation altitude

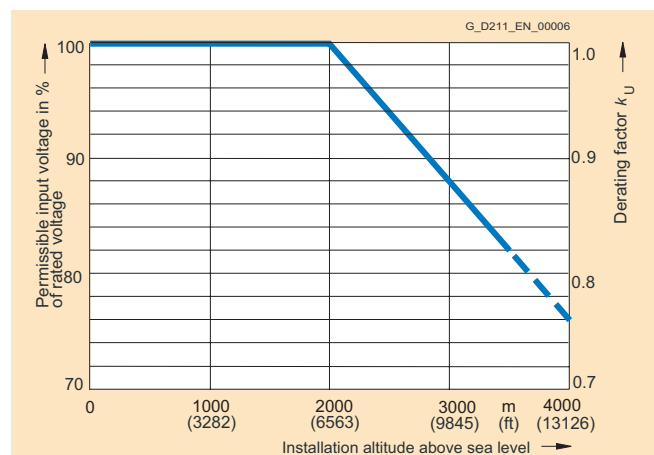

Voltage derating dependent on installation altitude

SINAMICS S120

Line Modules and line-side components

Active Interface Modules

Overview



Active Interface Modules are used in combination with Active Line Modules in chassis format. Active Interface Modules contain a clean power filter with basic RI suppression, the pre-charging circuit for the Active Line Module, the line voltage sensing circuit and monitoring sensors. The bypass contactor is an integral component in types FI and GI, thereby making the module very compact. The bypass contactor must be provided separately for types HI and JI.

The vast majority of line harmonics are suppressed by the clean power filter.

The scope of supply of the Active Interface Modules includes:

- Type FI:
 - 0.60 m (1.97 ft) DRIVE-CLiQ cable for connection between Active Interface Module and Active Line Module
 - 1.45 m (4.76 ft) DRIVE-CLiQ cable for connection between the CU320 or SIMOTION D Control Unit and first Motor Module.
- Type GI:
 - 0.95 m (3.12 ft) DRIVE-CLiQ cable for connection between Active Interface Module and Active Line Module
 - 1.45 m (4.76 ft) DRIVE-CLiQ cable for connection between the CU320 or SIMOTION D Control Unit and first Motor Module.
- Types HI and JI:
 - 2.40 m (7.88 ft) DRIVE-CLiQ cable for connection between Active Interface Module and Active Line Module

Selection and ordering data

Active Line Module infeed power kW (HP)	Suitable for Active Line Module	Active Interface Module Order No.
Line voltage 380 V to 480 V 3 AC		
132 (200)	6SL3330-7TE32-1AA0	6SL3300-7TE32-6AA0
160 (225)	6SL3330-7TE32-6AA0	6SL3300-7TE32-6AA0
235 (350)	6SL3330-7TE33-8AA0	6SL3300-7TE33-8AA0
300 (450)	6SL3330-7TE35-0AA0	6SL3300-7TE35-0AA0
380 (550)	6SL3330-7TE36-1AA0	6SL3300-7TE38-4AA0
500 (700)	6SL3330-7TE38-4AA0	6SL3300-7TE38-4AA0
630 (800)	6SL3330-7TE41-0AA0	6SL3300-7TE41-4AA0
900 (1150)	6SL3330-7TE41-4AA0	6SL3300-7TE41-4AA0
Line voltage 660 V to 690 V 3 AC		
560	6SL3330-7TH35-8AA0	6SL3300-7TH35-8AA0
800	6SL3330-7TH37-4AA0	6SL3300-7TH37-4AA0
1100	6SL3330-7TH41-0AA0	6SL3300-7TH41-3AA0
1400	6SL3330-7TH41-3AA0	6SL3300-7TH41-3AA0

Integration

2

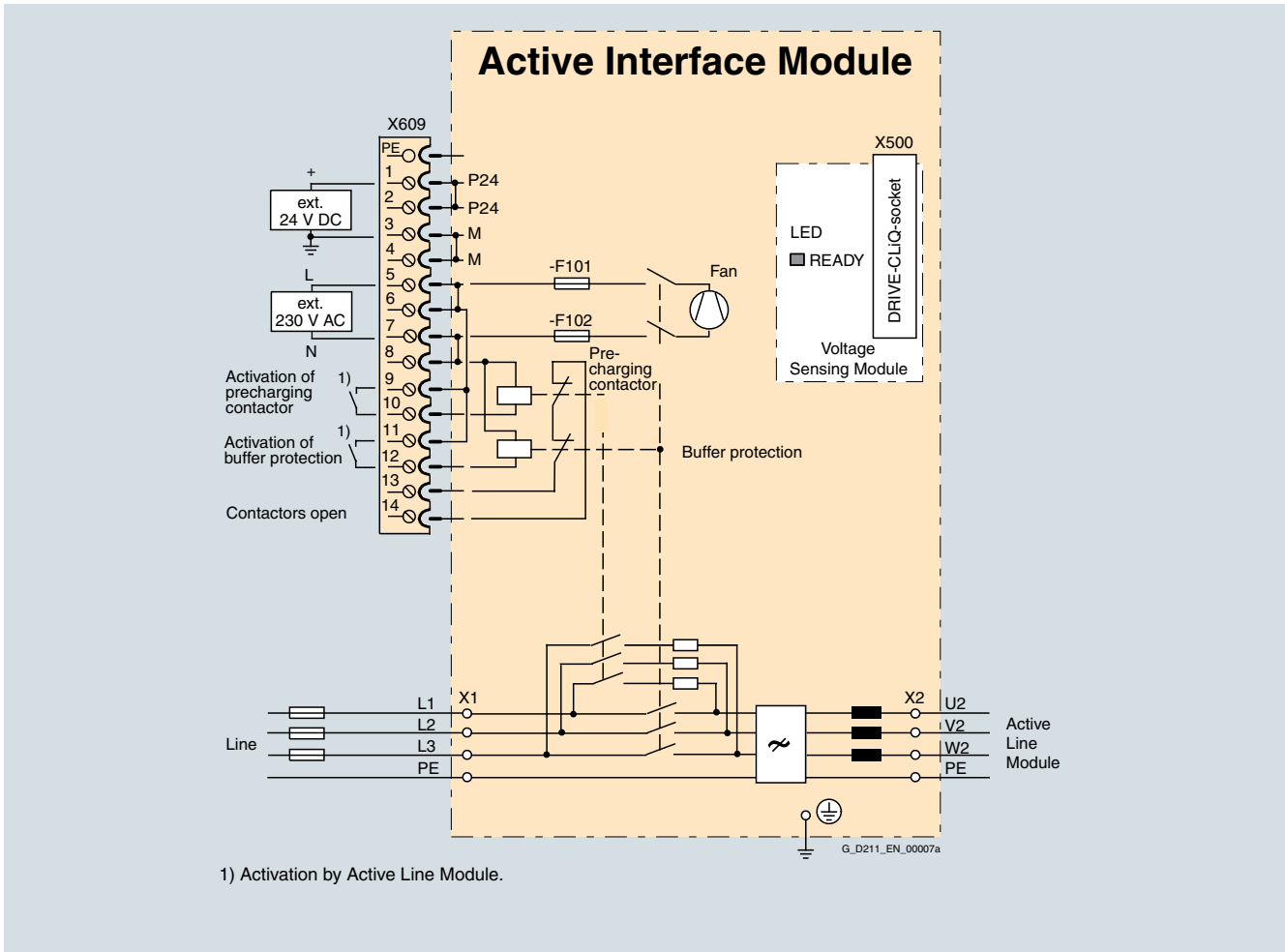

Connection example of Active Interface Module with integrated bypass contactor (types FI and GI)

SINAMICS S120

Line Modules and line-side components

Active Interface Modules

Integration (continued)

2

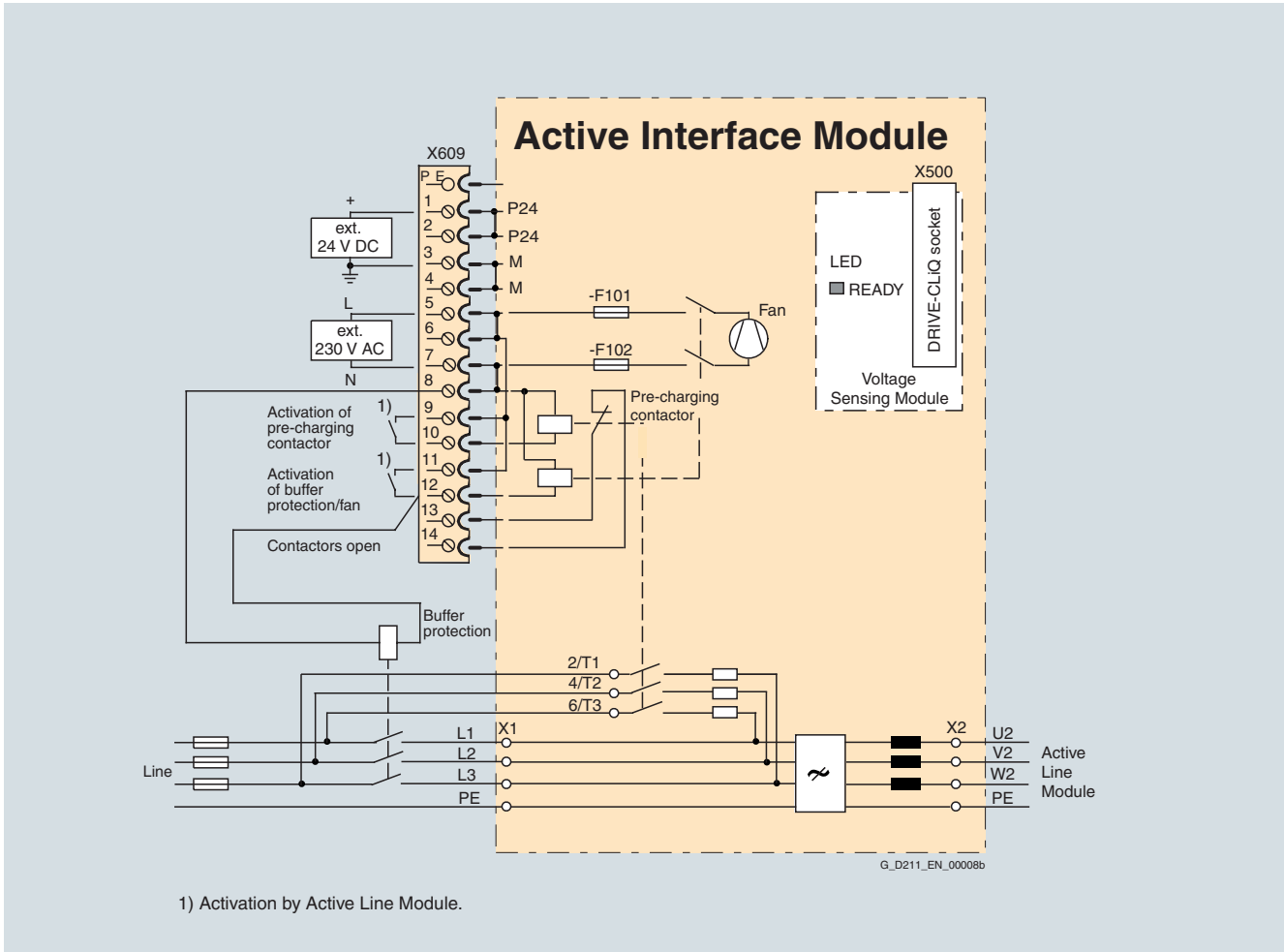

1) Activation by Active Line Module.

Connection example of Active Interface Module with externally mounted bypass contactor (types HI and JI)

Technical data

Line voltage 380 V to 480 V 3 AC		Active Interface Modules in chassis format			
		6SL3300-7TE32-6AA0		6SL3300-7TE33-8AA0	6SL3300-7TE35-0AA0
Rated current	A	210	260	380	490
Bypass contactor		included	included	included	included
Max. DC link capacitance of drive group					
• at 400 V/50 Hz	μF	31200	31200	57600	57600
• at 480 V/60 Hz	μF	20800	20800	38400	38400
Max. current requirement 24 V DC electronics power supply	A	0.17	0.17	0.17	0.17
Max. current requirement 230 V AC	A	0.6	0.6	1.2	1.2
Power loss	kW	2.1	2.2	3.0	3.9
Cooling air requirement	m ³ /s (ft ³ /s)	0.24 (8.48)	0.24 (8.48)	0.47 (16.6)	0.47 (16.6)
Sound pressure level ¹⁾ 50 Hz/60 Hz	dB(A)	74/76	75/77	76/78	76/78
Line/load connection L1, L2, L3 / U2, V2, W2		Flange connection with M10 screws	Flange connection with M10 screws	Flange connection with M10 screws	Flange connection with M10 screws
Max. conductor cross section		2 × 185 mm ² per connection	2 × 185 mm ² per connection	2 × 185 mm ² per connection	2 × 185 mm ² per connection
PE connection		M10 screw	M10 screw	M10 screw	M10 screw
Max. conductor cross section		2 × 185 mm ²	2 × 185 mm ²	2 × 185 mm ²	2 × 185 mm ²
Degree of protection		IP20	IP20	IP20	IP20
Width	mm (inch)	325 (12.8)	325 (12.8)	325 (12.8)	325 (12.8)
Height	mm (inch)	1400 (55.12)	1400 (55.12)	1533 (60.35)	1533 (60.35)
Depth	mm (inch)	355 (13.98)	355 (13.98)	544 (21.42)	544 (21.42)
Size		FI	FI	GI	GI
Weight, approx.	kg (lb)	135 (298)	135 (298)	190 (419)	190 (419)
Suitable for Active Line Module	Type	6SL3330-7TE32-1AA0	6SL3330-7TE32-6AA0	6SL3330-7TE33-8AA0	6SL3330-7TE35-0AA0
Active Line Module infeed power	kW (HP)	132 (200)	160 (225)	235 (350)	300 (450)

¹⁾ Total sound pressure level of Active Interface Module and Active Line Module.

SINAMICS S120

Line Modules and line-side components

Active Interface Modules

Technical data (continued)

Line voltage 380 V to 480 V 3 AC		Active Interface Modules in chassis format			
		6SL3300-7TE38-4AA0		6SL3300-7TE41-4AA0	
Rated current	A	605	840	985	1405
Bypass contactor		3RT1476-6AP36	3WL1110-2BB34-4AN2-Z C22	3WL1112-2BB34-4AN2-Z C22	3WL2226-2BB34-4AN2-Z C22
Max. DC link capacitance of drive group					
• at 400 V/50 Hz	μF	100800	100800	172800	172800
• at 480 V/60 Hz	μF	67200	67200	115200	115200
Max. current requirement 24 V DC electronics power supply	A	0.17	0.17	0.17	0.17
Max. current requirement 230 V AC	A	4.6	4.6	4.9	4.9
Power loss	kW	5.5	6.1	7.5	8.5
Cooling air requirement	m ³ /s (ft ³ /s)	0.4 (14.13)	0.4 (14.13)	0.4 (14.13)	0.4 (14.13)
Sound pressure level ¹⁾ 50 Hz/60 Hz	dB(A)	78/80	78/80	78/80	78/80
Line/load connection L1, L2, L3 / U2, V2, W2		Flange connection with M12 screws	Flange connection with M12 screws	Flange connection with M12 screws	Flange connection with M12 screws
Max. conductor cross section		4 × 240 mm ² per connection	4 × 240 mm ² per connection	6 × 240 mm ² per connection	6 × 240 mm ² per connection
PE connection		M12 screw	M12 screw	M12 screw	M12 screw
Max. conductor cross section		2 × 240 mm ²	2 × 240 mm ²	4 × 240 mm ²	4 × 240 mm ²
Degree of protection		IP00	IP00	IP00	IP00
Width	mm (inch)	305 (12)	305 (12)	505 (19.88)	505 (19.88)
Height	mm (inch)	1750 (68.9)	1750 (68.9)	1750 (68.9)	1750 (68.9)
Depth	mm (inch)	545 (21.46)	545 (21.46)	545 (21.46)	545 (21.46)
Size		HI	HI	JI	JI
Weight, approx.	kg (lb)	390 (860)	390 (860)	620 (1367)	620 (1367)
Suitable for Active Line Module	Type	6SL3330-7TE36-1AA0	6SL3330-7TE38-4AA0	6SL3330-7TE41-0AA0	6SL3330-7TE41-4AA0
Active Line Module infeed power	kW (HP)	380 (550)	500 (700)	630 (800)	900 (1150)

¹⁾ Total sound pressure level of Active Interface Module and Active Line Module.

Technical data (continued)

Line voltage 660 V to 690 V 3 AC		Active Interface Modules in chassis format			
		6SL3300-7TH35-8AA0	6SL3300-7TH37-4AA0	6SL3300-7TH41-3AA0	
Rated current	A	575	735	1025	1270
Bypass contactor		3RT1476-6AP36	3WL1210-4BB34-4AN2 ^{*)}	3WL1212-4BB34-4AN2-Z C22	3WL1216-4BB34-4AN2-Z C22
Max. DC link capacitance of drive group	μF	29600	76800	76800	76800
Max. current requirement 24 V DC electronics power supply	A	0.17	0.17	0.17	0.17
Max. current requirement 230 V AC	A	4.6	4.9	4.9	4.9
Power loss	kW	6.8	9.0	9.6	9.6
Cooling air requirement	m ³ /s (ft ³ /s)	0.4 (14.13)	0.4 (14.13)	0.4 (14.13)	0.4 (14.13)
Sound pressure level ¹⁾ 50 Hz/60 Hz	dB(A)	78/80	78/80	78/80	78/80
Line/load connection L1, L2, L3 / U2, V2, W2		Flange connection with M12 screws	Flange connection with M12 screws	Flange connection with M12 screws	Flange connection with M12 screws
Max. conductor cross sec- tion		4 × 240 mm ² per connection	6 × 240 mm ² per connection	6 × 240 mm ² per connection	6 × 240 mm ² per connection
PE connection		M10 fixing screw	M10 fixing screw	M10 fixing screw	M10 fixing screw
Max. conductor cross sec- tion		2 × 240 mm ²	4 × 240 mm ²	4 × 240 mm ²	4 × 240 mm ²
Degree of protection		IP00	IP00	IP00	IP00
Width	mm (inch)	305 (12)	505 (19.88)	505 (19.88)	505 (19.88)
Height	mm (inch)	1750 (68.9)	1750 (68.9)	1750 (68.9)	1750 (68.9)
Depth	mm (inch)	545 (21.46)	545 (21.46)	545 (21.46)	545 (21.46)
Size		HI	JI	JI	JI
Weight, approx.	kg (lb)	390 (860)	620 (1367)	620 (1367)	620 (1367)
Suitable for Active Line Module	Type	6SL3330-7TH35-8AA0	6SL3330-7TH37-4AA0	6SL3330-7TH41-0AA0	6SL3330-7TH41-3AA0
Active Line Module infeed power	kW	560	800	1100	1400

¹⁾ Total sound pressure level of Active Interface Module and Active Line Module.

^{*)} Alternatively 3x 3RT1466-6AP36.

SINAMICS S120

Line Modules and line-side components

Active Line Modules in chassis format Recommended line-side components

Overview

Assignment of line-side power components to Active Line Modules in chassis format

Suitable line-side power components are assigned depending on the power rating of the Active Line Modules.

The tables below list recommended components.

Further information about the main contactors, switch disconnectors, fuses and circuit-breakers specified in the tables can be found in Catalogs LV 1, LV 1T and ET B1. ¹⁾

Infeed power	Input current	Assignment to Active Interface Module	Assignment to Active Line Module	Bypass contactor	Fixed-mounted circuit-breaker
kW (HP)	A	Typ 6SL3300-...	Type 6SL3330-...	Order No.	Order No.
Line voltage 380 V to 480 V 3 AC					
132 (200)	210	7TE32-6AA0	7TE32-1AA0	included in Active Interface Module	–
160 (225)	260	7TE32-6AA0	7TE32-6AA0	included in Active Interface Module	–
235 (350)	380	7TE33-8AA0	7TE33-8AA0	included in Active Interface Module	–
300 (450)	490	7TE35-0AA0	7TE35-0AA0	included in Active Interface Module	–
380 (550)	605	7TE38-4AA0	7TE36-1AA0	3RT1476-6AP36	–
500 (700)	840	7TE38-4AA0	7TE38-4AA0	3WL1110-2BB34-4AN2	3WL1110-2BB34-4AN2-Z C22
630 (800)	985	7TE41-4AA0	7TE41-0AA0	3WL1112-2BB34-4AN2	3WL1112-2BB34-4AN2-Z C22
900 (1150)	1405	7TE41-4AA0	7TE41-4AA0	3WL1116-2BB34-4AN2	3WL1116-2BB34-4AN2-Z C22
Line voltage 660 V to 690 V 3 AC					
560	575	7TH35-8AA0	7TH35-8AA0	3RT1476-6AP36	–
800	735	7TH37-4AA0	7TH37-4AA0	3WL1210-4BB34-4AN2	3WL1210-4BB34-4AN2-Z C22
1100	1025	7TH41-3AA0	7TH41-0AA0	3WL1212-4BB34-4AN2	3WL1212-4BB34-4AN2-Z C22
1400	1270	7TH41-3AA0	7TH41-3AA0	3WL1216-4BB34-4AN2	3WL1216-4BB34-4AN2-Z C22

Infeed power	Input current	Assignment to Active Interface Module	Switch disconnector without handle and shaft	Switch disconnector with handle and shaft	Cable protection fuse		Cable protection fuse incl. semiconductor protection	
			Order No.	Order No.	Order No.	Rated current	Order No.	Rated current
Line voltage 380 V to 480 V 3 AC								
132 (200)	210	7TE32-6AA0	3KL5530-1AB01	3KL5530-1EB01	3NA3242	224 A	3NE1230-2	315 A
160 (225)	260	7TE32-6AA0	3KL5730-1AB01	3KL5730-1EB01	3NA3252	315 A	3NE1331-2	350 A
235 (350)	380	7TE33-8AA0	3KL5730-1AB01	3KL5730-1EB01	3NA3260	400 A	3NE1334-2	500 A
300 (450)	490	7TE35-0AA0	3KL6130-1AB02	3KL6130-1EB02	3NA3365	500 A	3NE1436-2	630 A
380 (550)	605	7TE38-4AA0	3KL6230-1AB02	3KL6230-1EB02	3NA3372	630 A	3NE1437-2	710 A
500 (700)	840	7TE38-4AA0	–	–	2 × 3NA3362	2 × 425 A	2 × 3NE1334-2	2 × 500 A
630 (800)	985	7TE41-4AA0	–	–	2 × 3NA3365	2 × 500 A	2 × 3NE1436-2	2 × 630 A
900 (1150)	1405	7TE41-4AA0	–	–	3 × 3NA3365	3 × 500 A	3 × 3NE1448-2	2 × 850 A
Line voltage 660 V to 690 V 3 AC								
560	575	7TH35-8AA0	3KL6130-1AB02	3KL6130-1EB02	2 × 3NA3352-6	2 × 315 A	3NE1447-2	670 A
800	735	7TH37-4AA0	3KL6230-1AB02	3KL6230-1EB02	2 × 3NA3360-6	2 × 400 A	3NE1448-2	850 A
1100	1025	7TH41-3AA0	–	–	3 × 3NA3354-6	3 × 355 A	2 × 3NE1436-2	2 × 630 A
1400	1270	7TH41-3AA0	–	–	3 × 3NA3365-6	3 × 500 A	2 × 3NE1438-2	2 × 800 A

1) Component selections are per IEC standards and not necessarily in accordance with UL or NEC requirements. For NEMA components please see North American Industrial Products Catalog and Speedfax Catalog.

Overview

A wide range of single-axis and two-axis Motor Modules with graded current/power ratings can be supplied:

- Single Motor Modules: Single-axis variant
 - Booksize format with rated output currents of 3 A to 200 A
 - Chassis format with rated output currents of 85 A to 1405 A
- Double Motor Modules: Two-axis variant
 - Booksize format with rated output currents of 3 A to 18 A

In principle, all Single and Double Motor Modules can be operated on Basic Line Modules, Smart Line Modules or Active Line Modules for the appropriate voltage range.

Single Motor Modules in booksize format

Design



The Single Motor Modules in booksize format feature the following interfaces as standard:

- 2 DC link connections via integrated DC link busbars
- 1 electronics power supply connection via integrated 24 V DC bars
- 3 DRIVE-CLiQ sockets
- 1 motor connection, plug-in (not included in scope of supply) or screw-stud depending on rated output current
- 1 safe standstill input (enable pulses)
- 1 safe motor brake control
- 1 temperature sensor input (KTY84-130 or PTC)
- 2 PE (protective earth) connections

The status of the Motor Modules is indicated via two multi-color LEDs.

The motor cable shield is inside the connector on 50 mm (1.97 in) and 100 mm (3.94 in) width modules. A shield connection kit can be supplied for 150 mm (5.91 in), 200 mm (7.87 in) and 300 mm (11.81 in) wide modules. On these modules, the motor cable shield can be connected using a tube clip.

The signal cable shield can be connected to the Motor Module by means of a shield connection terminal, e.g. Weidmüller type KLBÜ 3-8 SC.

The scope of supply of the Motor Modules includes:

- DRIVE-CLiQ cable (length depends on module width) to connect Motor Module to adjacent module
- Jumper for connecting the 24 V DC busbar to the adjacent Motor Module
- Connector X21
- Connector X11 for the motor brake connection (for Motor Modules with a rated output current of 45 A to 200 A)

SINAMICS S120

Motor Modules

Single Motor Modules in booksize format

Integration

Single Motor Modules communicate with the CU320 or SIMOTION D Control Unit via DRIVE-CLiQ.

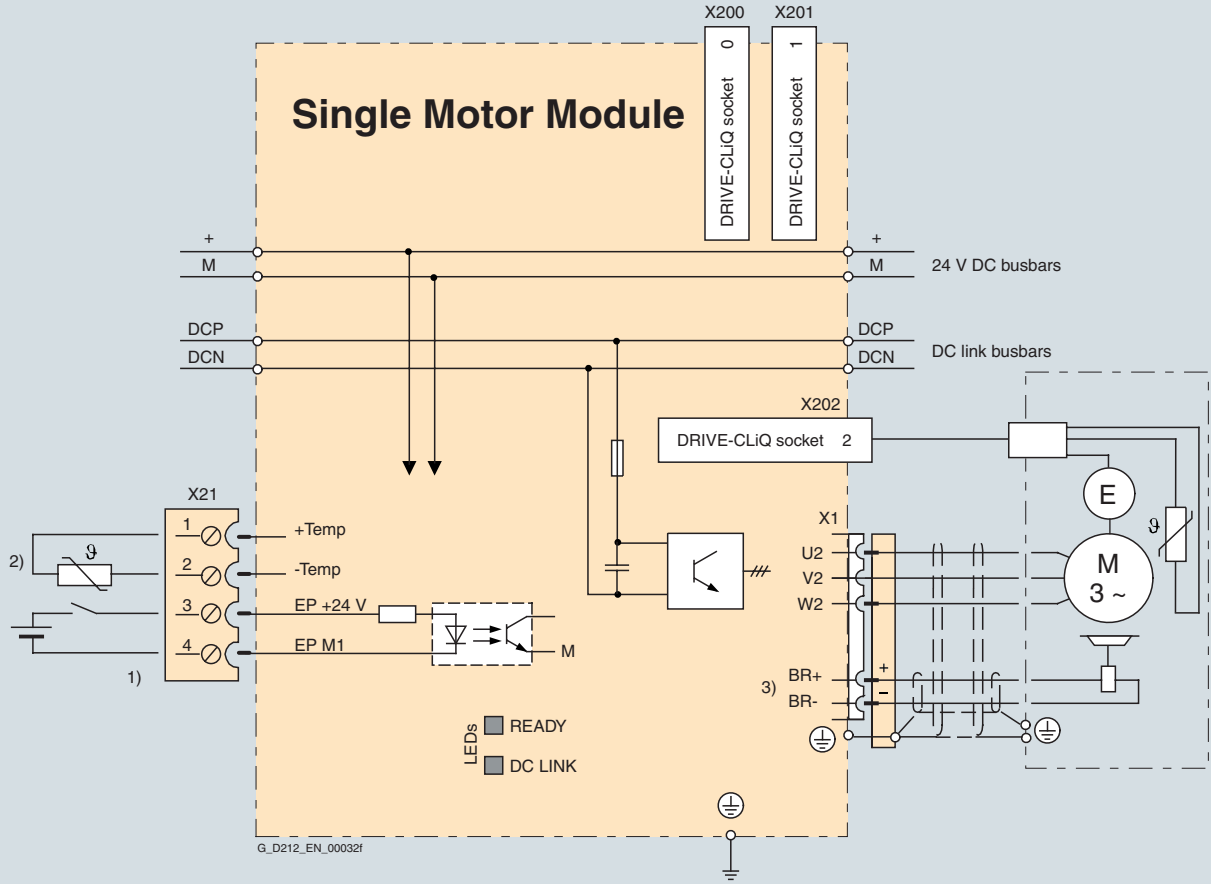

- 1) Required for Safety.
- 2) Temperature sensor terminal for motors without DRIVE-CLiQ interface.
- 3) The braking signal has an integrated overvoltage protection.
An external circuit of the holding brake is not necessary.

Connection example of Single Motor Modules in booksize format 3 A to 30 A

Integration (continued)

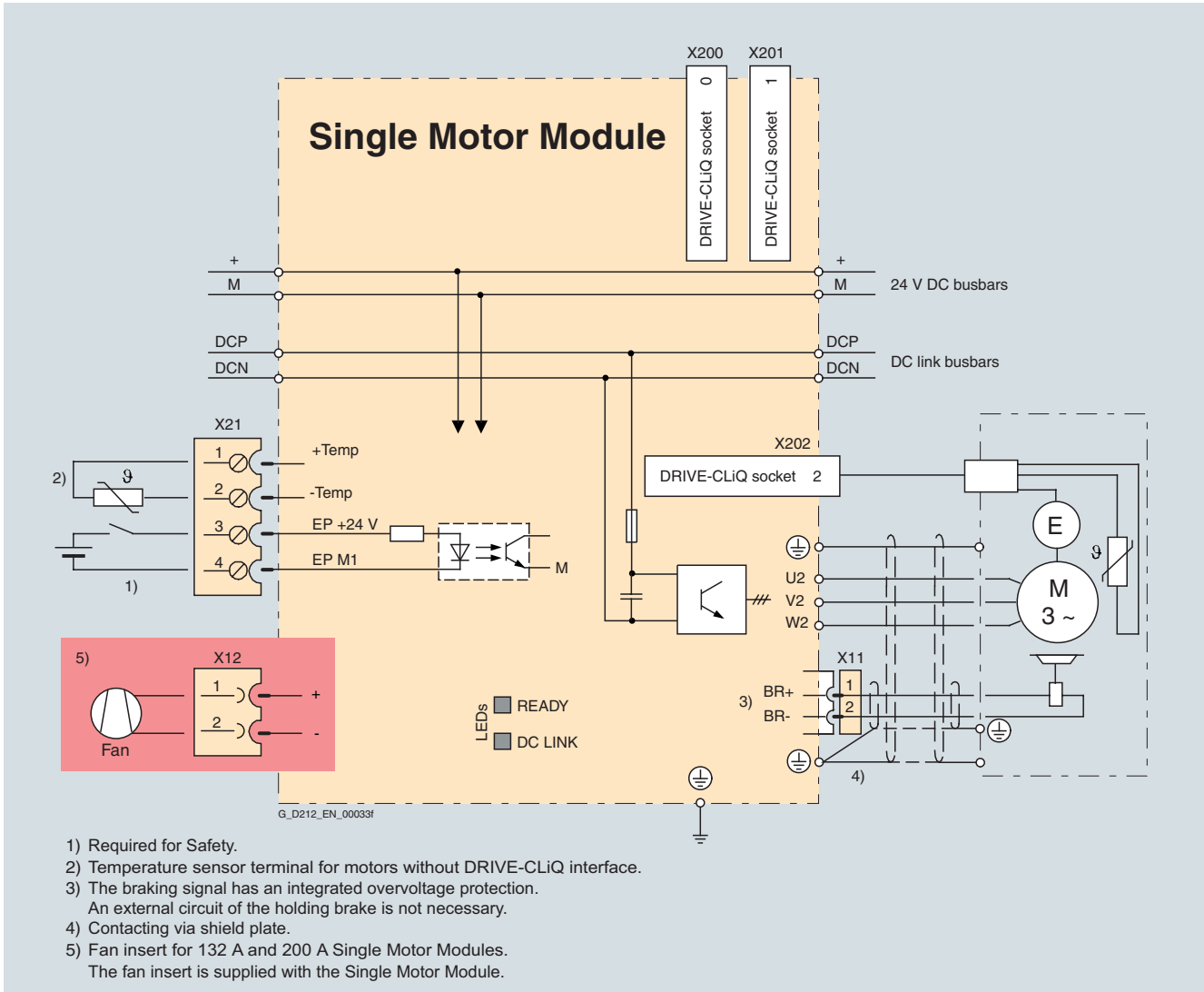

Connection example of Single Motor Modules in booksize format 45 A to 200 A

SINAMICS S120

Motor Modules

Single Motor Modules in booksize format

Technical data

General technical data

Electrical data	
DC link voltage (up to 2000 m (6563 ft) above sea level)	510 V to 720 V DC (line voltage 380 V to 480 V 3 AC)
max. output voltage, line-to-line (fundamental-wave RMS value)	0.67 x DC link voltage
Output frequency	
• Control type Servo	0 Hz to 650 Hz ¹⁾
• Control type Vector	0 Hz to 300 Hz ¹⁾
• Control type V/f	0 Hz to 300 Hz ¹⁾
Electronics power supply	24 V DC – 15%/+ 20%
Radio interference suppression	
• Standard	No radio interference suppression
• in combination with Line Module incl. line filter and line reactor	Class A1 to EN 55011 and Category C2 to EN 61800-3
Ambient conditions	
Type of cooling	Forced air cooling through built-in fan
Permissible ambient and coolant temperature (air) during operation for line-side components, Line Modules and Motor Modules	0 °C to + 40 °C (32 °F to + 104 °F) without derating, > 40 °C to + 55 °C (> 104 °F to + 131 °F) see derating characteristics
Site altitude	Up to 1000 m (1328 ft) above sea level without derating, > 1000 m (1328 ft) to 4000 m (13126 ft) above sea level see derating characteristics
Certificates	
Conformity	CE (low-voltage and EMC Directives)
Approvals	cULus (File No.: E192450)
Certification	Safety Integrity Level 2 (SIL 2) to IEC 61508, control category 3 to EN 954-1 for Safety Integrated – safe standstill (STO = Safe Torque Off) and safe brake control (SBC = Safe Brake Control)

¹⁾ Note correlation between max. output frequency, pulse frequency and current derating, see System Description.

Technical data (continued)

DC link voltage 510 V to 720 V DC		Single Motor Modules in booksize format					
Internal air cooling		6SL3120-1TE13-0AA0	6SL3120-1TE15-0AA0	6SL3120-1TE21-0AA1	6SL3120-1TE21-8AA1	6SL3120-1TE23-0AA1	
Internal air cooling with varnished modules		6SL3120-1TE13-0AB0	6SL3120-1TE15-0AB0	6SL3120-1TE21-0AB0	6SL3120-1TE21-8AB0	6SL3120-1TE23-0AB0	
External air cooling		6SL3121-1TE13-0AA0	6SL3121-1TE15-0AA0	6SL3121-1TE21-0AA0	6SL3121-1TE21-8AA0	6SL3121-1TE23-0AA0	
Rated output current I_{rated}	A	3	5	9	18	30	
Base load current I_H	A	2.6	4.3	7.7	15.3	25.5	
Output current for S6 duty (40%) I_{S6}	A	3.5	6	10	24	40	
Max. output current I_{max}	A	6	10	18	36	56	
Rated power for 600 V DC link voltage	kW (HP)	1.6 (1.5)	2.7 (3)	4.8 (5)	9.7 (10)	16.0 (20)	
Power based on I_H for 600 V DC link voltage	kW (HP)	1.4 (1)	2.3 (2.5)	4.1 (5)	8.2 (10)	13.7 (18)	
Rated pulse frequency	kHz	4	4	4	4	4	
DC link current $I_d^{(1)}$	A	3.6	6	11	22	36	
DC link busbar current capacity	A	100	100	100	100	100	
DC link capacitance	μF	110	110	110	220	710	
Max. current requirement at 24 V DC	A	0.85	0.85	0.85	0.85	0.9	
24 V DC busbar current capacity	A	20	20	20	20	20	
		If, due to a number of Line and Motor Modules being mounted side-by-side, the current carrying capacity exceeds 20 A, an additional 24 V DC connection using a 24-V terminal adapter is required (max. cross section 6 mm ² , max. fuse protection 20 A).					
Efficiency η		0.97	0.97	0.97	0.97	0.97	
Power loss with internal air cooling in control cabinet	kW	0.035	0.055	0.080	0.165	0.290	
Power loss ²⁾ with external air cooling int./ext.	kW	0.015/0.015	0.023/0.03	0.035/0.045	0.075/0.09	0.08/0.21	
Cooling air requirement	m ³ /s (ft ³ /s)	0.008 (0.283)	0.008 (0.283)	0.008 (0.283)	0.008 (0.283)	0.016 (0.565)	
Sound pressure level	dB(A)	< 60	< 60	< 60	< 60	< 60	
Motor connection U2, V2, W2		Plug-in connector (X1), max. 30 A (not included in scope of supply, see Accessories)	Plug-in connector (X1), max. 30 A (not included in scope of supply, see Accessories)	Plug-in connector (X1), max. 30 A (not included in scope of supply, see Accessories)	Plug-in connector (X1), max. 30 A (not included in scope of supply, see Accessories)	Plug-in connector (X1), max. 30 A (not included in scope of supply, see Accessories)	
Shield connection		integrated in connector (X1)	integrated in connector (X1)	integrated in connector (X1)	integrated in connector (X1)	integrated in connector (X1)	
PE connection		On housing with M5 screw	On housing with M5 screw	On housing with M5 screw	On housing with M5 screw	On housing with M5 screw	
Motor brake connection		Integrated into the plug-in motor connector (X1), 24 V DC, 2 A	Integrated into the plug-in motor connector (X1), 24 V DC, 2 A	Integrated into the plug-in motor connector (X1), 24 V DC, 2 A	Integrated into the plug-in motor connector (X1), 24 V DC, 2 A	Integrated into the plug-in motor connector (X1), 24 V DC, 2 A	
Max. motor cable length	m (ft)	50 (164) shielded 75 (246) unshielded	50 (164) shielded 75 (246) unshielded	50 (164) shielded 75 (246) unshielded	70 (230) shielded 100 (328) unshielded	100 (328) shielded 150 (492) unshielded	
Degree of protection		IP20	IP20	IP20	IP20	IP20	
Width	mm (inch)	50 (1.97)	50 (1.97)	50 (1.97)	50 (1.97)	100 (3.94)	
Height	mm (inch)	380 (14.98)	380 (14.98)	380 (14.98)	380 (14.98)	380 (14.98)	
Depth with internal air cooling	mm (inch)	270 (10.63)	270 (10.63)	270 (10.63)	270 (10.63)	270 (10.63)	
Depth with external air cooling on/behind mounting surface	mm (inch)	226/66.5 (8.9/2.6)	226/66.5 (8.9/2.6)	226/66.5 (8.9/2.6)	226/66.5 (8.9/2.6)	226/66.5 (8.9/2.6)	
Approx. weight with internal air cooling	kg (lb)	5.1 (11)	5.1 (11)	5.0 (11)	5.0 (11)	6.9 (15)	
Approx. weight with external air cooling	kg (lb)	5.7 (13)	5.7 (13)	5.7 (13)	5.7 (13)	8.5 (19)	

¹⁾ Rated DC link current for dimensioning an external DC connection. For DC link current calculation for dimensioning the Line Module, see System Description.

²⁾ Power loss of Motor Module at rated output without losses of 24 V DC electronics power supply.

SINAMICS S120

Motor Modules

Single Motor Modules in booksize format

Technical data (continued)

DC link voltage 510 V to 720 V DC		Single Motor Modules in booksize format					
Internal air cooling		6SL3120-1TE24-5AA1	6SL3120-1TE26-0AA1	6SL3120-1TE28-5AA1	6SL3120-1TE31-3AA0	6SL3120-1TE32-0AA0	
Internal air cooling with varnished modules		6SL3120-1TE24-5AB0	6SL3120-1TE26-0AB0	6SL3120-1TE28-5AB0	6SL3120-1TE31-3AB0	6SL3120-1TE32-0AB0	
External air cooling		6SL3121-1TE24-5AA0	6SL3121-1TE26-0AA0	6SL3121-1TE28-5AA0	6SL3121-1TE31-3AA0	6SL3121-1TE32-0AA0	
Rated output current I_{rated}	A	45	60	85	132	200	
Base load current I_H	A	38	52	68	105	141	
Output current for S6 duty (40%) I_{S6}	A	60	80	110	150	230	
Max. output current I_{max}	A	85	113	141	210	282	
Rated pulse frequency	kHz	4	4	4	4	4	
Rated power for 600 V DC link voltage	kW (HP)	24 (30)	32 (40)	46 (60)	71 (100)	107 (150)	
Power based on I_H 600 V DC link voltage	kW (HP)	21 (25)	28 (40)	37 (50)	57 (75)	76 (100)	
DC link current $I_d^{(1)}$	A	54	72	102	158	200	
DC link busbar current capacity	A	100	100	200	200	200	
DC link capacitance	μF	1175	1410	1880	2820	3995	
Max. current requirement at 24 V DC	A	1.2	1.2	1.5	1.5	1.5	
24 V DC busbar current capacity	A	20	20	20	20	20	
		If, due to a number of Line and Motor Modules being mounted side-by-side, the current carrying capacity exceeds 20 A, an additional 24 V DC connection using a 24 V terminal adapter is required (max. cross section 6 mm ² , max. fuse protection 20 A).					
Efficiency η		0.97	0.97	0.97	0.97	0.97	
Power loss with internal air cooling in control cabinet	kW	0.43	0.59	0.75	1.25	2.05	
Power loss ²⁾ with external air cooling int./ext.	kW	0.11/0.32	0.135/0.455	0.16/0.59	0.25/1.0	0.4/1.65	
Cooling air requirement	m ³ /s (ft ³ /s)	0.031 (1.095)	0.031 (1.095)	0.044 (1.554)	0.144 (5.085)	0.144 (5.085)	
Sound pressure level	dB(A)	< 65	< 65	< 60	< 73	< 73	
Motor connection U2, V2, W2		M6 screw studs, 2.5 mm ² to 50 mm ² (X1)	M6 screw studs, 2.5 mm ² to 50 mm ² (X1)	M8 screw studs, 2.5 mm ² to 95 mm ² , 2 × 35 mm ² (X1)	M8 screw studs, 2.5 mm ² to 120 mm ² , 2 × 50 mm ² (X1)	M8 screw studs, 2.5 mm ² to 120 mm ² , 2 × 50 mm ² (X1)	
Shield connection		see Accessories	see Accessories	see Accessories	see Accessories	see Accessories	
PE connection		On housing with M6 screw	On housing with M6 screw	On housing with M6 screw	On housing with M8 screw	On housing with M8 screw	
Motor brake connection		Plug-in connector (X11), 24 V DC, 2 A	Plug-in connector (X11), 24 V DC, 2 A	Plug-in connector (X11), 24 V DC, 2 A	Plug-in connector (X11), 24 V DC, 2 A	Plug-in connector (X11), 24 V DC, 2 A	
Max. motor cable length	m (ft)	100 (328) shielded 150 (492) unshielded	100 (328) shielded 150 (492) unshielded	1100 (328) shielded 150 (492) unshielded	100 (328) shielded 150 (492) unshielded	100 (328) shielded 150 (492) unshielded	
Degree of protection		IP20	IP20	IP20	IP20	IP20	
Width	mm (inch)	150 (5.91)	150 (5.91)	200 (7.87)	300 (11.81)	300 (11.81)	
Height	mm (inch)	380 (14.96)	380 (14.96)	380 (14.96)	380, (14.96) with fan ³⁾ ; 629 (24.8)	380, (14.96) with fan ³⁾ ; 629 (24.8)	
Depth with internal air cooling	mm (inch)	270 (10.63)	270 (10.63)	270 (10.63)	270 (10.63)	270 (10.63)	
Depth with external air cooling on/behind mounting surface	mm (inch)	226/71 (8.9/2.8)	226/71 (8.9/2.8)	226/92 (8.9/3.6)	226/82 (8.9/3.2)	226/82 (8.9/3.2)	
Approx. weight with internal air cooling	kg (lb)	9 (20)	9 (20)	15 (33)	21 (46)	21 (46)	
Approx. weight with external air cooling	kg (lb)	13.2 (29)	13.4 (30)	17.2 (38)	27.2 (60)	30 (66)	

¹⁾ Rated DC link current for dimensioning an external DC connection. For DC link current calculation for dimensioning the Line Module, see System Description.

²⁾ Power loss of Motor Module at rated output without losses of 24 V DC electronics power supply.

³⁾ The fan is supplied with the Motor Module and must be installed before the Motor Module is commissioned.

Selection and ordering data

Rated output current A	Rated power kW (HP) ¹⁾	Single Motor Module in booksize format		
		Internal air cooling Order No.	Internal air cooling with varnished modules Order No.	External air cooling Order No.
DC link voltage 510 V to 720 V DC				
3	1.6 (1.5)	6SL3120-1TE13-0AA0	6SL3120-1TE13-0AB0	6SL3121-1TE13-0AA0
5	2.7 (3)	6SL3120-1TE15-0AA0	6SL3120-1TE15-0AB0	6SL3121-1TE15-0AA0
9	4.8 (5)	6SL3120-1TE21-0AA1	6SL3120-1TE21-0AB0	6SL3121-1TE21-0AA0
18	9.7 (10)	6SL3120-1TE21-8AA1	6SL3120-1TE21-8AB0	6SL3121-1TE21-8AA0
30	16 (20)	6SL3120-1TE23-0AA1	6SL3120-1TE23-0AB0	6SL3121-1TE23-0AA0
45	24 (30)	6SL3120-1TE24-5AA1	6SL3120-1TE24-5AB0	6SL3121-1TE24-5AA0
60	32 (40)	6SL3120-1TE26-0AA1	6SL3120-1TE26-0AB0	6SL3121-1TE26-0AA0
85	46 (60)	6SL3120-1TE28-5AA1	6SL3120-1TE28-5AB0	6SL3121-1TE28-5AA0
132	71 (100)	6SL3120-1TE31-3AA0	6SL3120-1TE31-3AB0	6SL3121-1TE31-3AA0
200	107 (150)	6SL3120-1TE32-0AA0	6SL3120-1TE32-0AB0	6SL3121-1TE32-0AA0

Accessories

Description	Order No.
Power connector (X1) At Motor Module end, with screw-type terminals 1.5 mm ² to 10 mm ² , for Motor Modules with a rated output current of 3 to 30 A	6SL3162-2MA00-0AA0
Shield connection kit for Line/Motor Modules in booksize format <ul style="list-style-type: none"> • 150 mm (5.91 in) wide for internal air cooling • 150 mm (5.91 in) wide for external air cooling • 200 mm (7.87 in) wide for internal air cooling • 200 mm (7.87 in) wide for external air cooling • 300 mm (11.81 in) wide 	6SL3162-1AF00-0AA1 6SL3162-1AF00-0BA0 6SL3162-1AH01-0AA0 6SL3162-1AH01-0BA0 6SL3162-1AH00-0AA0
DC link supply adapter for direct infeed of DC link voltage <ul style="list-style-type: none"> • Screw-type terminals 0.5 mm² to 10 mm² for Line Modules and Motor Modules in booksize format with a width of 50 mm (1.97 in) or 100 mm (3.84 in) • Screw-type terminals 35 mm² to 95 mm² for Line Modules and Motor Modules in booksize format with a width of 150 mm (5.91 in), 200 mm (7.87 in) and 300 mm (11.81 in) 	6SL3162-2BD00-0AA0 6SL3162-2BM00-0AA0
DC link adapters (2x) for multi-tier configuration Screw-type terminals 35 mm ² to 95 mm ² for all Line Modules/Motor Modules in booksize format	6SL3162-2BM01-0AA0
24 V terminal adapter for all Line Modules/Motor Modules in booksize format	6SL3162-2AA00-0AA0
24 V jumper for connection of the 24 V busbars (for booksize format)	6SL3162-2AA01-0AA0
Warning signs in foreign languages This set of foreign language warning signs can be placed on top of the standard German or English signs. One sign in each of the following languages is provided in each set: Chinese Simplified, Danish, Dutch, Finnish, French, Greek, Italian, Japanese, Korean, Portuguese, Spanish and Swedish.	6SL3166-3AB00-0AA0
Plug-in motor brake connector for booksize format Motor Modules with a rated output current of 45 A to 200 A Wago http://www.wago.com	Item No.: 231-102/037-000 (Wago)

¹⁾ Nominal HP based on Asynchronous motors (induction motors).
 Match the motor nameplate current for specific sizing.

Characteristics

Overload capability

2

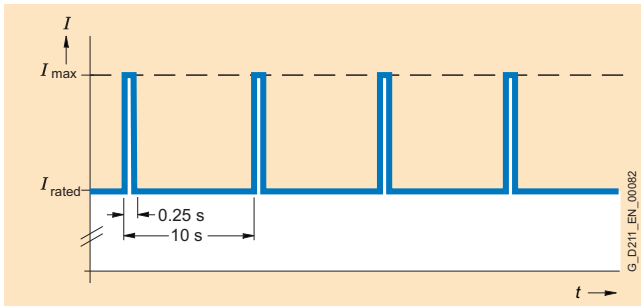

Load cycle with previous load

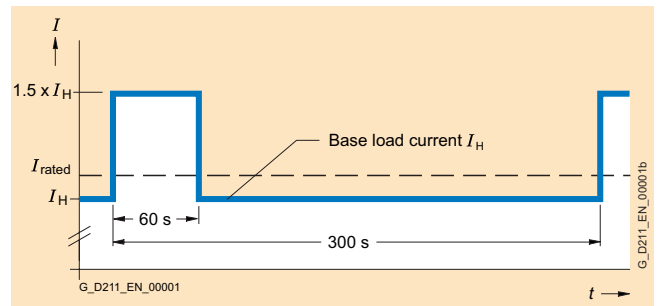

Load cycle with 60 s overload with a load cycle period of 300 s

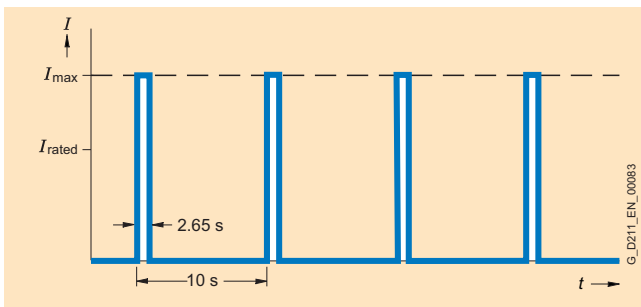

Load cycle without previous load

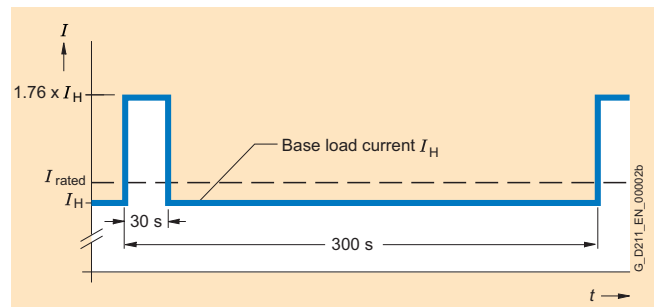

Load cycle with 30 s overload with a load cycle period of 300 s

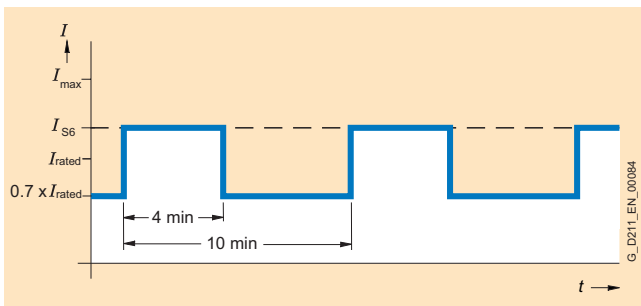

S6 load cycle with previous load with a load cycle period of 600 s

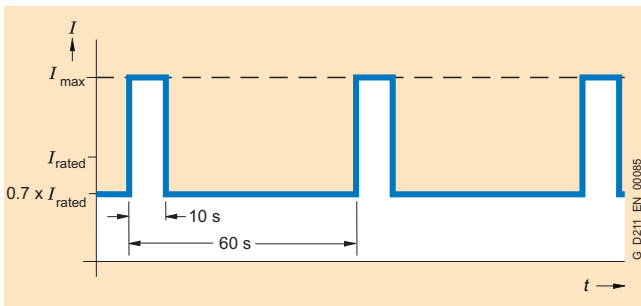

S6 load cycle with previous load with a load cycle period of 60 s

Characteristics (continued)

Derating characteristics

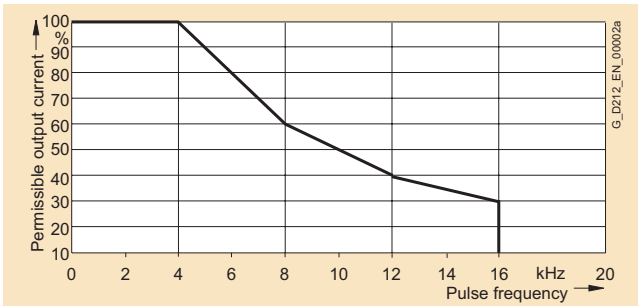

Output current dependent on pulse frequency

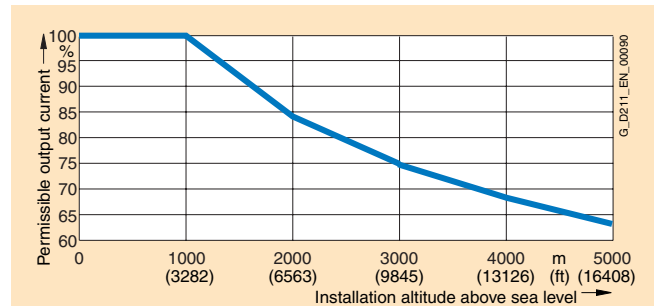

Output current dependent on installation altitude

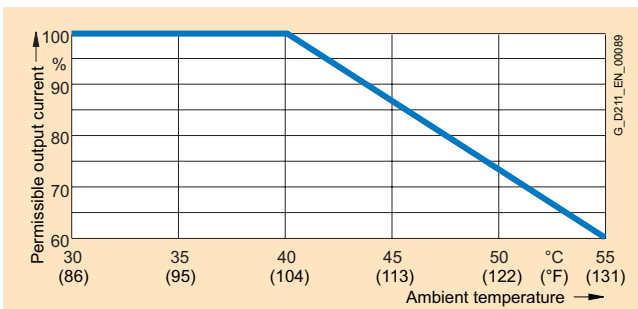

Output current dependent on ambient temperature

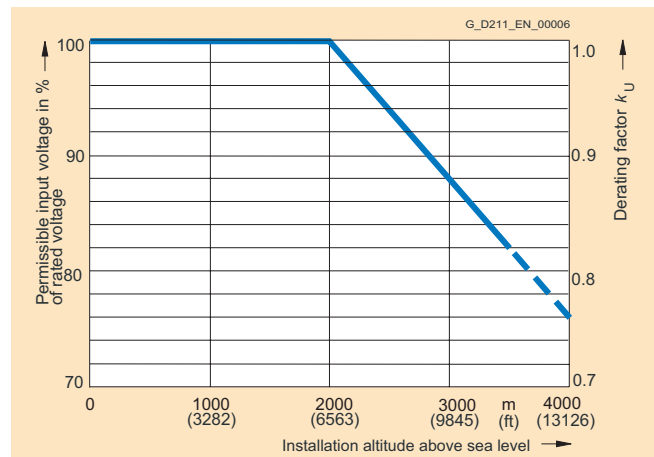

Voltage derating dependent on installation altitude

SINAMICS S120

Motor Modules

Single Motor Modules in chassis format

Design

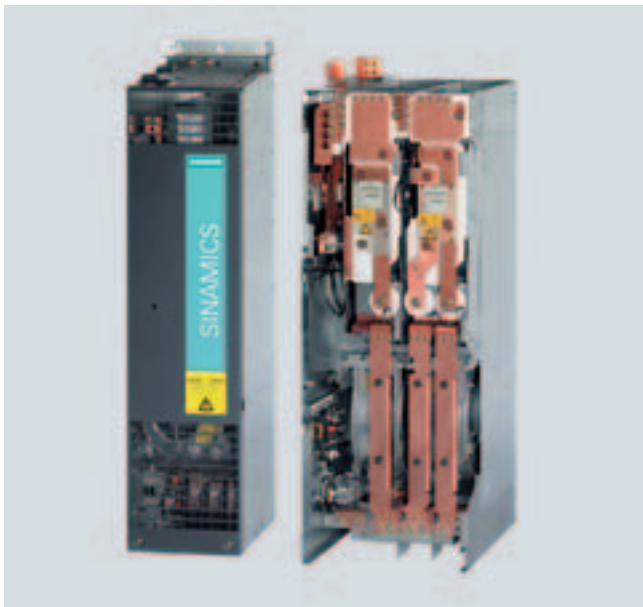

The Single Motor Modules in chassis format feature the following interfaces as standard:

- 1 DC link connection
- 1 electronics power supply connection
- 3 DRIVE-CLiQ sockets
- 1 motor connection
- 1 safe standstill input (enable pulses)
- 1 temperature sensor input (KTY84-130 or PTC)
- 1 PE (protective earth) connection

The status of the Motor Modules is indicated via two multi-color LEDs.

The scope of supply of the Motor Modules includes:

- Types FX and GX:
 - 0.60 m (1.97 ft) DRIVE-CLiQ cable for connection to the adjacent Motor Module
- Types HX and JX:
 - 0.35 m (1.15 ft) DRIVE-CLiQ cable for connection to the CU320 or SIMOTION D Control Unit
 - 2.10 m (6.89 ft) DRIVE-CLiQ cable for connection to the adjacent Motor Module

Selection and ordering data

Rated output current A	Rated power kW (HP) ¹⁾	Single Motor Module in chassis format Order No.
DC link voltage 510 V to 720 V DC		
210	110 (150)	6SL3320-1TE32-1AA0
260	132 (200)	6SL3320-1TE32-6AA0
310	160 (250)	6SL3320-1TE33-1AA0
380	200 (300)	6SL3320-1TE33-8AA0
490	250 (400)	6SL3320-1TE35-0AA0
605	315 (500)	6SL3320-1TE36-1AA0
745	400 (600)	6SL3320-1TE37-5AA0
840	450 (700)	6SL3320-1TE38-4AA0
985	560 (800)	6SL3320-1TE41-0AA0
1260	710 (1000)	6SL3320-1TE41-2AA0
1405	800 (1150)	6SL3320-1TE41-4AA0
DC link voltage 890 V to 1035 V DC		
85	75	6SL3320-1TH28-5AA0
100	90	6SL3320-1TH31-0AA0
120	110	6SL3320-1TH31-2AA0
150	132	6SL3320-1TH31-5AA0
175	160	6SL3320-1TH31-8AA0
215	200	6SL3320-1TH32-2AA0
260	250	6SL3320-1TH32-6AA0
330	315	6SL3320-1TH33-3AA0
410	400	6SL3320-1TH34-1AA0
465	450	6SL3320-1TH34-7AA0
575	560	6SL3320-1TH35-8AA0
735	710	6SL3320-1TH37-4AA0
810	800	6SL3320-1TH38-1AA0
910	900	6SL3320-1TH38-8AA0
1025	1000	6SL3320-1TH41-0AA0
1270	1200	6SL3320-1TH41-3AA0

Warning signs in foreign languages

Warning signs in other languages can be placed on top of the standard warning signs in German or English.

The following signs are supplied with chassis format units: Chinese, Danish, Finnish, French, Greek, Italian, Japanese, Korean, Dutch, Polish, Portuguese, Russian, Swedish, Spanish, Czech and Turkish.

¹⁾ Nominal HP based on Asynchronous motors (induction motors). Match the motor nameplate current for specific sizing.

Integration

The Single Motor Module communicates with the CU320 or SIMOTION D Control Unit via DRIVE-CLiQ.

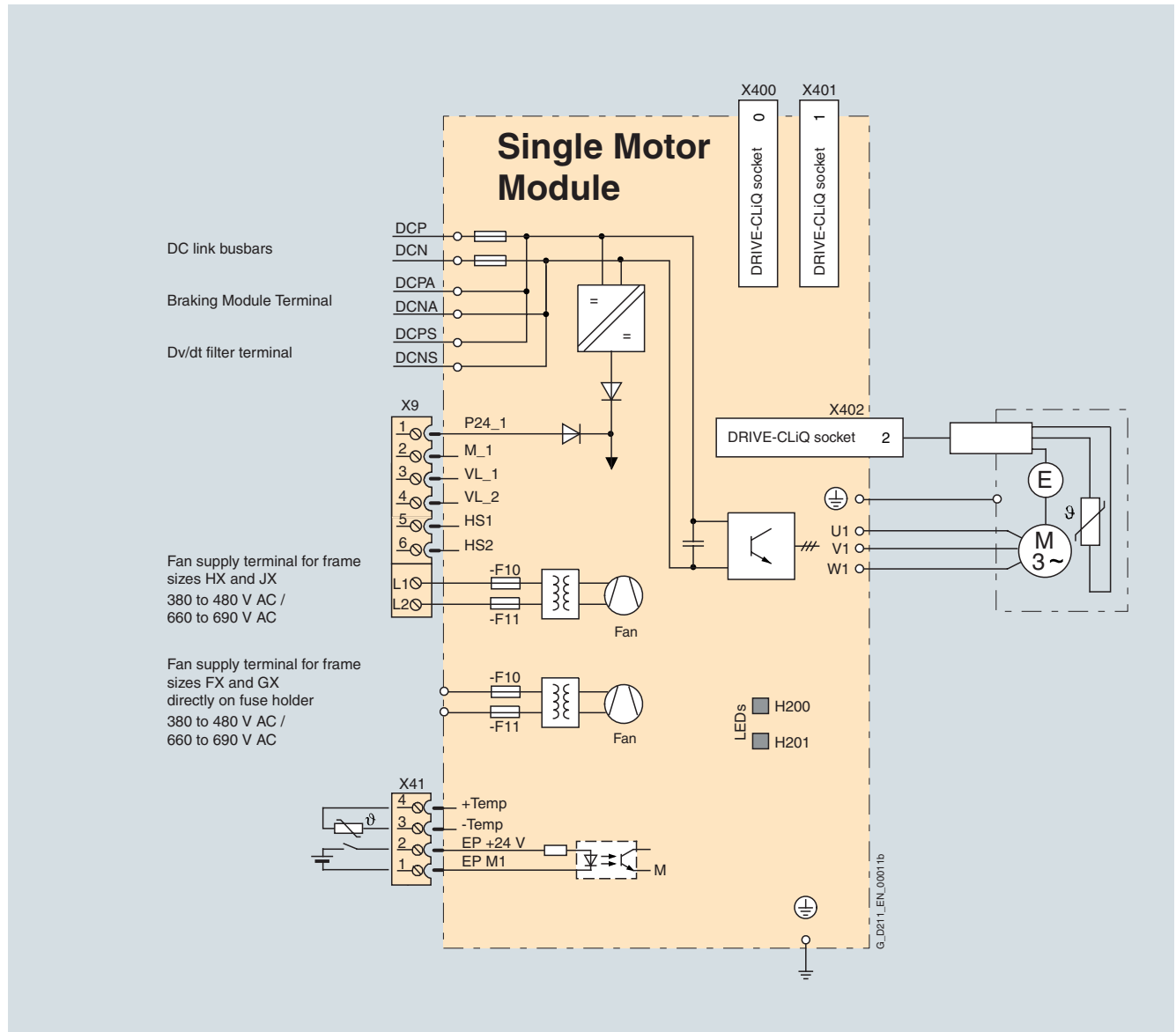

Connection example of Single Motor Module in chassis format

SINAMICS S120

Motor Modules

Single Motor Modules in chassis format

Technical data

General technical data

Electrical data	
DC link voltage (up to 2000 m (6563 ft) above sea level)	510 V to 720 V DC (line voltage 380 V to 480 V 3 AC) or 890 V to 1035 V DC (line voltage 660 V to 690 V 3 AC)
Max output voltage, line-to-line (fundamental-wave RMS value)	0.72 x DC link voltage
Output frequency	
• Control type Servo	0 Hz to 650 Hz ¹⁾
• Control type Vector	0 Hz to 300 Hz ¹⁾
• Control type V/f	0 Hz to 300 Hz ¹⁾
Electronics power supply	24 V DC – 15%/+ 20%
Radio interference suppression	
• Standard	No radio interference suppression
• in combination with Line Module and line reactor	Category C3 to EN 61800-3
• in combination with Line Module incl. line filter and line reactor	Class A1 to EN 55011 and Category C2 to EN 61800-3
Ambient conditions	
Type of cooling	Internal/external air cooling, power units with increased air cooling by means of built-in fan
Permissible ambient and coolant temperature (air) during operation for line-side components, Line Modules and Motor Modules	0 °C to + 40 °C (32 °F to + 104 °F) without derating, > 40 °C to + 55 °C (> 104 °F to + 131 °F) see derating characteristics
Site altitude	Up to 2000 m (6563 ft) above sea level without derating, > 2000 m (6563 ft) to 4000 m (13126 ft) above sea level see derating characteristics
Certificates	
Conformity	CE (low-voltage and EMC Directives)
Approvals	cULus (File No.: E192450)
Certification	Safety Integrity Level 2 (SIL 2) to IEC 61508, control category 3 to EN 954-1 for Safety Integrated – safe standstill (STO = Safe Torque Off)

¹⁾ Note correlation between max. output frequency, pulse frequency and current derating, see System Description.

Technical data (continued)

DC link voltage 510 V to 720 V DC		Single Motor Modules in chassis format				
		6SL3320-1TE32-1AA0	6SL3320-1TE32-6AA0	6SL3320-1TE33-1AA0	6SL3320-1TE33-8AA0	6SL3320-1TE35-0AA0
Rated output current I_{rated}	A	210	260	310	380	490
Base load current I_L	A	205	250	302	370	477
Base load current I_H	A	178	233	277	340	438
Max. output current I_{max}	A	307	375	453	555	715
Rated power 600 V DC link voltage	kW (HP)	110 (150)	132 (200)	160 (250)	200 (300)	250 (400)
Power based on I_H 600 V DC link voltage	kW (HP)	90 (125)	110 (150)	132 (200)	160 (250)	200 (350)
Rated pulse frequency	kHz	2	2	2	2	2
DC link current $I_d^{1)}$	A	252	312	372	456	588
DC link capacitance	μ F	4200	5200	6300	7800	9600
Max. current requirement at 24 V DC	A	0.8	0.8	0.9	0.9	0.9
Max. current requirement (fan supply) at 400 V \pm 2 AC	A	0.6	1.2	1.6	1.6	1.6
Efficiency η		0.986	0.986	0.986	0.986	0.986
Power loss	kW	1.86	2.50	2.96	3.67	4.28
Cooling air requirement	m ³ /s (ft ³ /s)	0.17 (6)	0.23 (8.12)	0.36 (12.71)	0.36 (12.71)	0.36 (12.71)
Sound pressure level	dB(A)	< 67	< 69	< 69	< 69	< 69
DC link connection DCP, DCN		Flange connection with M10 screw, max. cross section 2 x 185 mm ²	Flange connection with M10 screw, max. cross section 2 x 185 mm ²	Flange connection with M10 screw, max. cross section 2 x 185 mm ²	Flange connection with M10 screw, max. cross section 2 x 185 mm ²	Flange connection with M10 screw, max. cross section 2 x 185 mm ²
Motor connection U2, V2, W2		Flange connection with M10 screw, max. cross section 2 x 185 mm ²	Flange connection with M10 screw, max. cross section 2 x 185 mm ²	Flange connection with M10 screw, max. cross section 2 x 185 mm ²	Flange connection with M10 screw, max. cross section 2 x 185 mm ²	Flange connection with M10 screw, max. cross section 2 x 185 mm ²
PE connection		Flange connection with M10 screw, max. cross section 2 x 185 mm ²	Flange connection with M10 screw, max. cross section 2 x 185 mm ²	Flange connection with M10 screw, max. cross section 2 x 185 mm ²	Flange connection with M10 screw, max. cross section 2 x 185 mm ²	Flange connection with M10 screw, max. cross section 2 x 185 mm ²
Motor brake connection		–	–	–	–	–
Max. motor cable length (without external options)	m (ft)	300 (984) shielded 450 (1477) unshielded	300 (984) shielded 450 (1477) unshielded	300 (984) shielded 450 (1477) unshielded	300 (984) shielded 450 (1477) unshielded	300 (984) shielded 450 (1477) unshielded
Degree of protection		IP20	IP20	IP20	IP20	IP20
Width	mm (inch)	326 (12.83)	326 (12.83)	326 (12.83)	326 (12.83)	326 (12.83)
Height	mm (inch)	1400 (55.12)	1400 (55.12)	1533 (60.35)	1533 (60.35)	1533 (60.35)
Depth	mm (inch)	356 (14.02)	356 (14.02)	545 (21.46)	545 (21.46)	545 (21.46)
Size		FX	FX	GX	GX	GX
Weight, approx.	kg (lb)	88 (194)	88 (194)	152 (335)	152 (335)	152 (335)

¹⁾ Rated DC link current for dimensioning an external DC connection.
For DC link current calculation for dimensioning the Line Module, see System Description.

SINAMICS S120

Motor Modules

Single Motor Modules in chassis format

Technical data (continued)

DC link voltage 510 V to 720 V DC		Single Motor Modules in chassis format		
		6SL3320-1TE36-1AA0	6SL3320-1TE37-5AA0	6SL3320-1TE38-4AA0
Rated output current I_{rated}	A	605	745	840
Base load current I_L	A	590	725	820
Base load current I_H	A	460	570	700
Max. output current I_{max}	A	885	1087	1230
Rated power 600 V DC link voltage	kW (HP)	315 (500)	400 (600)	450 (700)
Power based on I_H 600 V DC link voltage	kW (HP)	250 (350)	315 (450)	400 (500)
Rated pulse frequency	kHz	1.25	1.25	1.25
DC link current $I_d^{1)}$	A	726	894	1008
DC link capacitance	μ F	12600	15600	16800
Max. current requirement at 24 V DC	A	1.0	1.0	1.0
Max. current requirement (fan supply) at 400 V 2 AC	A	3.2	3.2	3.2
Efficiency η		0.986	0.986	0.986
Power loss	kW	5.84	6.68	7.15
Cooling air requirement	m^3/s (ft^3/s)	0.78 (27.55)	0.78 (27.55)	0.78 (27.55)
Sound pressure level	dB(A)	< 72	< 72	< 72
DC link connection DCP, DCN		Flange connection for busbar connection	Flange connection for busbar connection	Flange connection for busbar connection
Motor connection U2, V2, W2		Flange connection with M12 screw, max. cross section $4 \times 240 \text{ mm}^2$	Flange connection with M12 screw, max. cross section $4 \times 240 \text{ mm}^2$	Flange connection with M12 screw, max. cross section $4 \times 240 \text{ mm}^2$
PE connection		On housing with M12 screw, max. cross section PE1/GND $1 \times 240 \text{ mm}^2$ PE2/GND $2 \times 240 \text{ mm}^2$	On housing with M12 screw, max. cross section PE1/GND $1 \times 240 \text{ mm}^2$ PE2/GND $2 \times 240 \text{ mm}^2$	On housing with M12 screw, max. cross section PE1/GND $1 \times 240 \text{ mm}^2$ PE2/GND $2 \times 240 \text{ mm}^2$
Motor brake connection		–	–	–
Max. motor cable length (without external options)	m (ft)	300 (984) shielded 450 (1477) unshielded	300 (984) shielded 450 (1477) unshielded	300 (984) shielded 450 (1477) unshielded
Degree of protection		IP00	IP00	IP00
Width	mm (inch)	503 (19.8)	503 (19.8)	503 (19.8)
Height	mm (inch)	1475 (58.07)	1475 (58.07)	1475 (58.07)
Depth	mm (inch)	540 (21.26)	540 (21.26)	540 (21.26)
Size		HX	HX	HX
Weight, approx.	kg (lb)	290 (640)	290 (640)	290 (640)

¹⁾ Rated DC link current for dimensioning an external DC connection.
For DC link current calculation for dimensioning the Line Module, see System Description.

Technical data (continued)

DC link voltage 510 V to 720 V DC		Single Motor Modules in chassis format		
		6SL3320-1TE41-0AA0	6SL3320-1TE41-2AA0	6SL3320-1TE41-4AA0
Rated output current I_{rated}	A	985	1260	1405
Base load current I_L	A	960	1230	1370
Base load current I_H	A	860	1127	1257
Max. output current I_{max}	A	1440	1845	2055
Rated power 600 V DC link voltage	kW (HP)	560 (800)	710 (1000)	800 (1150)
Power based on I_H 600 V DC link voltage	kW (HP)	450 (700)	560 (900)	710 (1000)
Rated pulse frequency	kHz	1.25	1.25	1.25
DC link current $I_d^{1)}$	A	1182	1512	1686
DC link capacitance	μ F	18900	26100	28800
Max. current requirement at 24 V DC	A	1.25	1.40	1.40
Max. current requirement (fan supply) at 400 V 2 AC	A	4.7	4.7	4.7
Efficiency η		0.986	0.986	0.986
Power loss	kW	9.5	11.1	12.0
Cooling air requirement	m^3/s (ft^3/s)	1.1 (38.85)	1.1 (38.85)	1.1 (38.85)
Sound pressure level	dB(A)	< 72	< 72	< 72
DC link connection DCP, DCN		Flange connection for busbar connection	Flange connection for busbar connection	Flange connection for busbar connection
Motor connection U2, V2, W2		Flange connection with M12 screw, max. cross section $6 \times 240 \text{ mm}^2$	Flange connection with M12 screw, max. cross section $6 \times 240 \text{ mm}^2$	Flange connection with M12 screw, max. cross section $6 \times 240 \text{ mm}^2$
PE connection		On housing with M12 screw, max. cross section PE1/GND $1 \times 240 \text{ mm}^2$ PE2/GND $2 \times 240 \text{ mm}^2$	On housing with M12 screw, max. cross section PE1/GND $1 \times 240 \text{ mm}^2$ PE2/GND $2 \times 240 \text{ mm}^2$	On housing with M12 screw, max. cross section PE1/GND $1 \times 240 \text{ mm}^2$ PE2/GND $2 \times 240 \text{ mm}^2$
Motor brake connection		–	–	–
Max. motor cable length (without external options)	m (ft)	300 (984) shielded 450 (1477) unshielded	300 (984) shielded 450 (1477) unshielded	300 (984) shielded 450 (1477) unshielded
Degree of protection		IP00	IP00	IP00
Width	mm (inch)	704 (27.72)	704 (27.72)	704 (27.72)
Height	mm (inch)	1475 (58.07)	1475 (58.07)	1475 (58.07)
Depth	mm (inch)	540 (21.26)	540 (21.26)	540 (21.26)
Size		JX	JX	JX
Weight, approx.	kg (lb)	450 (992)	450 (992)	450 (992)

¹⁾ Rated DC link current for dimensioning an external DC connection.
For DC link current calculation for dimensioning the Line Module, see System Description.

SINAMICS S120

Motor Modules

Single Motor Modules in chassis format

Technical data (continued)

DC link voltage 890 V to 1035 V DC		Single Motor Modules in chassis format			
		6SL3320-1TH28-5AA0	6SL3320-1TH31-0AA0	6SL3320-1TH31-2AA0	6SL3320-1TH31-5AA0
Rated output current I_{rated}	A	85	100	120	150
Base load current I_L	A	80	95	115	142
Base load current I_H	A	76	89	107	134
Max. output current I_{max}	A	120	142	172	213
Rated power	kW	75	90	110	132
Power based on I_H	kW	55	75	90	110
Rated pulse frequency	kHz	1.25	1.25	1.25	1.25
DC link current $I_d^{1)}$	A	102	120	144	180
DC link capacitance	μ F	1200	1200	1600	2800
Max. current requirement at 24 V DC	A	0.8	0.8	0.8	0.8
Max. current requirement (fan supply) at 690 V 2 AC	A	0.4	0.4	0.4	0.4
Efficiency η		0.988	0.988	0.986	0.989
Power loss	kW	1.17	1.43	1.89	1.80
Cooling air requirement	m ³ /s (ft ³ /s)	0.17 (6)	0.17 (6)	0.17 (6)	0.17 (6)
Sound pressure level	dB(A)	< 67	< 67	< 67	< 67
DC link connection DCP, DCN		Flange connection with M10 screw, max. cross section 2 x 185 mm ²	Flange connection with M10 screw, max. cross section 2 x 185 mm ²	Flange connection with M10 screw, max. cross section 2 x 185 mm ²	Flange connection with M10 screw, max. cross section 2 x 185 mm ²
Motor connection U2, V2, W2		Flange connection with M10 screw, max. cross section 2 x 185 mm ²	Flange connection with M10 screw, max. cross section 2 x 185 mm ²	Flange connection with M10 screw, max. cross section 2 x 185 mm ²	Flange connection with M10 screw, max. cross section 2 x 185 mm ²
PE connection		Flange connection with M12 screw, max. cross section PE1/GND 2 x 185 mm ² PE2/GND 2 x 185 mm ²	Flange connection with M12 screw, max. cross section PE1/GND 2 x 185 mm ² PE2/GND 2 x 185 mm ²	Flange connection with M12 screw, max. cross section PE1/GND 2 x 185 mm ² PE2/GND 2 x 185 mm ²	Flange connection with M12 screw, max. cross section PE1/GND 2 x 185 mm ² PE2/GND 2 x 185 mm ²
Motor brake connection		–	–	–	–
Max. motor cable length (without external options)	m (ft)	300 (984) shielded 450 (1477) unshielded	300 (984) shielded 450 (1477) unshielded	300 (984) shielded 450 (1477) unshielded	300 (984) shielded 450 (1477) unshielded
Degree of protection		IP20	IP20	IP20	IP20
Width	mm (inch)	326 (12.83)	326 (12.83)	326 (12.83)	326 (12.83)
Height	mm (inch)	1400 (55.12)	1400 (55.12)	1400 (55.12)	1400 (55.12)
Depth	mm (inch)	356 (14.02)	356 (14.02)	356 (14.02)	356 (14.02)
Size		FX	FX	FX	FX
Weight, approx.	kg (lb)	88 (194)	88 (194)	88 (194)	88 (194)

¹⁾ Rated DC link current for dimensioning an external DC connection.
For DC link current calculation for dimensioning the Line Module, see System Description.

Technical data (continued)

DC link voltage 890 V to 1035 V DC		Single Motor Modules in chassis format			
		6SL3320-1TH31-8AA0	6SL3320-1TH32-2AA0	6SL3320-1TH32-6AA0	6SL3320-1TH33-3AA0
Rated output current I_{rated}	A	175	215	260	330
Base load current I_L	A	170	208	250	320
Base load current I_H	A	157	192	233	280
Max. output current I_{max}	A	255	312	375	480
Rated power	kW	160	200	250	315
Power based on I_H	kW	132	160	200	250
Rated pulse frequency	kHz	1.25	1.25	1.25	1.25
DC link current $I_d^{1)}$	A	210	258	312	396
DC link capacitance	μ F	2800	2800	3900	4200
Max. current requirement at 24 V DC	A	0.9	0.9	0.9	0.9
Max. current requirement (fan supply) at 690 V 2 AC	A	0.94	0.94	0.94	0.94
Efficiency η		0.987	0.988	0.988	0.987
Power loss	kW	2.67	3.09	3.62	4.34
Cooling air requirement	m^3/s (ft ³ /s)	0.36 (12.71)	0.36 (12.71)	0.36 (12.71)	0.36 (12.71)
Sound pressure level	dB(A)	< 69	< 69	< 69	< 69
DC link connection DCP, DCN		Flange connection with M10 screw, max. cross section $2 \times 185 \text{ mm}^2$	Flange connection with M10 screw, max. cross section $2 \times 185 \text{ mm}^2$	Flange connection with M10 screw, max. cross section $2 \times 185 \text{ mm}^2$	Flange connection with M10 screw, max. cross section $2 \times 185 \text{ mm}^2$
Motor connection U2, V2, W2		Flange connection with M10 screw, max. cross section $2 \times 185 \text{ mm}^2$	Flange connection with M10 screw, max. cross section $2 \times 185 \text{ mm}^2$	Flange connection with M10 screw, max. cross section $2 \times 185 \text{ mm}^2$	Flange connection with M10 screw, max. cross section $2 \times 185 \text{ mm}^2$
PE connection		Flange connection with M12 screw, max. cross section PE1/GND $2 \times 185 \text{ mm}^2$ PE2/GND $2 \times 185 \text{ mm}^2$	Flange connection with M12 screw, max. cross section PE1/GND $2 \times 185 \text{ mm}^2$ PE2/GND $2 \times 185 \text{ mm}^2$	Flange connection with M12 screw, max. cross section PE1/GND $2 \times 185 \text{ mm}^2$ PE2/GND $2 \times 185 \text{ mm}^2$	Flange connection with M12 screw, max. cross section PE1/GND $2 \times 185 \text{ mm}^2$ PE2/GND $2 \times 185 \text{ mm}^2$
Motor brake connection		–	–	–	–
Max. motor cable length (without external options)	m (ft)	300 (984) shielded 450 (1477) unshielded	300 (984) shielded 450 (1477) unshielded	300 (984) shielded 450 (1477) unshielded	300 (984) shielded 450 (1477) unshielded
Degree of protection		IP20	IP20	IP20	IP20
Width	mm (inch)	326 (12.83)	326 (12.83)	326 (12.83)	326 (12.83)
Height	mm (inch)	1533 (60.35)	1533 (60.35)	1533 (60.35)	1533 (60.35)
Depth	mm (inch)	545 (21.46)	545 (21.46)	545 (21.46)	545 (21.46)
Size		GX	GX	GX	GX
Weight, approx.	kg (lb)	152 (335)	152 (335)	152 (335)	152 (335)

¹⁾ Rated DC link current for dimensioning an external DC connection.
For DC link current calculation for dimensioning the Line Module, see System Description.

SINAMICS S120

Motor Modules

Single Motor Modules in chassis format

Technical data (continued)

DC link voltage 890 V to 1035 V DC		Single Motor Modules in chassis format			
		6SL3320-1TH34-1AA0	6SL3320-1TH34-7AA0	6SL3320-1TH35-8AA0	6SL3320-1TH37-4AA0
Rated output current I_{rated}	A	410	465	575	735
Base load current I_L	A	400	452	560	710
Base load current I_H	A	367	416	514	675
Max. output current I_{max}	A	600	678	840	1065
Rated power	kW	400	450	560	710
Power based on I_H	kW	315	400	450	630
Rated pulse frequency	kHz	1.25	1.25	1.25	1.25
DC link current $I_d^{1)}$	A	492	558	690	882
DC link capacitance	μ F	7400	7400	7400	11100
Max. current requirement at 24 V DC	A	1.0	1.0	1.0	1.25
Max. current requirement (fan supply) at 690 V 2 AC	A	1.84	1.84	2.74	2.74
Efficiency η		0.987	0.985	0.988	0.988
Power loss	kW	6.13	6.80	10.3	10.9
Cooling air requirement	m^3/s (ft ³ /s)	0.78 (27.55)	0.78 (27.55)	0.78 (27.55)	1.474 (52.05)
Sound pressure level	dB(A)	< 72	< 72	< 72	< 72
DC link connection DCP, DCN		Flange connection for busbar connection	Flange connection for busbar connection	Flange connection for busbar connection	Flange connection for busbar connection
Motor connection U2, V2, W2		Flange connection with M12 screw, max. cross section 4 x 240 mm ²	Flange connection with M12 screw, max. cross section 4 x 240 mm ²	Flange connection with M12 screw, max. cross section 4 x 240 mm ²	Flange connection with M12 screw, max. cross section 4 x 240 mm ²
PE connection		Flange connection with M12 screw, max. cross section PE1/GND 1 x 240 mm ² PE2/GND 2 x 240 mm ²	Flange connection with M12 screw, max. cross section PE1/GND 1 x 240 mm ² PE2/GND 2 x 240 mm ²	Flange connection with M12 screw, max. cross section PE1/GND 1 x 240 mm ² PE2/GND 2 x 240 mm ²	Flange connection with M12 screw, max. cross section PE1/GND 1 x 240 mm ² PE2/GND 2 x 240 mm ²
Motor brake connection		–	–	–	–
Max. motor cable length (without external options)	m (ft)	300 (984) shielded 450 (1477) unshielded	300 (984) shielded 450 (1477) unshielded	300 (984) shielded 450 (1477) unshielded	300 (984) shielded 450 (1477) unshielded
Degree of protection		IP00	IP00	IP00	IP00
Width	mm (inch)	503 (19.8)	503 (19.8)	503 (19.8)	704 (27.72)
Height	mm (inch)	1475 (58.07)	1475 (58.07)	1475 (58.07)	1475 (58.07)
Depth	mm (inch)	540 (21.26)	540 (21.26)	540 (21.26)	540 (21.26)
Size		HX	HX	HX	JX
Weight, approx.	kg (lb)	290 (640)	290 (640)	290 (640)	450 (992)

¹⁾ Rated DC link current for dimensioning an external DC connection.
For DC link current calculation for dimensioning the Line Module, see System Description.

Technical data (continued)

DC link voltage 890 V to 1035 V DC		Single Motor Modules in chassis format			
		6SL3320-1TH38-1AA0	6SL3320-1TH38-8AA0	6SL3320-1TH41-0AA0	6SL3320-1TH41-3AA0
Rated output current I_{rated}	A	810	910	1025	1270
Base load current I_L	A	790	880	1000	1230
Base load current I_H	A	724	814	917	1136
Max. output current I_{max}	A	1185	1320	1500	1845
Rated power	kW	800	900	1000	1200
Power based on I_H	kW	710	800	900	1000
Rated pulse frequency	kHz	1.25	1.25	1.25	1.25
DC link current $I_d^{1)}$	A	972	1092	1230	1524
DC link capacitance	μ F	11100	14400	14400	19200
Max. current requirement at 24 V DC	A	1.25	1.4	1.4	1.4
Max. current requirement (fan supply) at 690 V 2 AC	A	2.74	2.74	2.74	2.74
Efficiency η		0.988	0.989	0.989	0.989
Power loss	kW	11.5	11.7	13.2	16.0
Cooling air requirement	m^3/s (ft^3/s)	1.474 (52.05)	1.474 (52.05)	1.474 (52.05)	1.474 (52.05)
Sound pressure level	dB(A)	< 72	< 72	< 72	< 72
DC link connection DCP, DCN		Flange connection for busbar connection	Flange connection for busbar connection	Flange connection for busbar connection	Flange connection for busbar connection
Motor connection U2, V2, W2		Flange connection with M12 screw, max. cross section $4 \times 240 \text{ mm}^2$	Flange connection with M12 screw, max. cross section $4 \times 240 \text{ mm}^2$	Flange connection with M12 screw, max. cross section $4 \times 240 \text{ mm}^2$	Flange connection with M12 screw, max. cross section $6 \times 240 \text{ mm}^2$
PE connection		Flange connection with M12 screw, max. cross section PE1/GND $1 \times 240 \text{ mm}^2$ PE2/GND $2 \times 240 \text{ mm}^2$	Flange connection with M12 screw, max. cross section PE1/GND $1 \times 240 \text{ mm}^2$ PE2/GND $2 \times 240 \text{ mm}^2$	Flange connection with M12 screw, max. cross section PE1/GND $1 \times 240 \text{ mm}^2$ PE2/GND $2 \times 240 \text{ mm}^2$	Flange connection with M12 screw, max. cross section PE1/GND $1 \times 240 \text{ mm}^2$ PE2/GND $2 \times 240 \text{ mm}^2$
Motor brake connection		–	–	–	–
Max. motor cable length (without external options)	m (ft)	300 (984) shielded 450 (1477) unshielded	300 (984) shielded 450 (1477) unshielded	300 (984) shielded 450 (1477) unshielded	300 (984) shielded 450 (1477) unshielded
Degree of protection		IP00	IP00	IP00	IP00
Width	mm (inch)	704 (27.72)	704 (27.72)	704 (27.72)	704 (27.72)
Height	mm (inch)	1475 (58.07)	1475 (58.07)	1475 (58.07)	1475 (58.07)
Depth	mm (inch)	540 (21.26)	540 (21.26)	540 (21.26)	540 (21.26)
Size		JX	JX	JX	JX
Weight, approx.	kg (lb)	450 (992)	450 (992)	450 (992)	450 (992)

¹⁾ Rated DC link current for dimensioning an external DC connection.
For DC link current calculation for dimensioning the Line Module, see System Description.

SINAMICS S120

Motor Modules

Single Motor Modules in chassis format

Characteristics

Overload capability

Load cycle data for Single Motor Modules in chassis format

The base load current I_L is based on a load cycle of 110% for 60 s or 150% for 10 s with a load cycle period of 300 s.

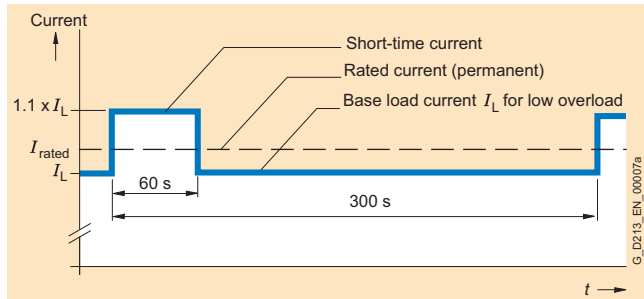

Low overload

The base load current I_H is based on a load cycle of 150% for 60 s or 160% for 10 s with a load cycle period of 300 s.

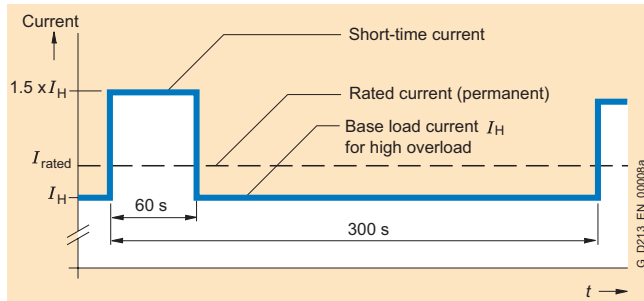

High overload

Derating factors

When the pulse frequency is increased, the derating factor of the output current must be taken into account.

This derating factor must be applied to the currents specified in the technical data.

Derating factor of the output current as a function of the pulse frequency for devices with a rated pulse frequency of 2-kHz

Single Motor Module in chassis format	Output	Output current	Derating factor	
Type		for a pulse frequency of 2 kHz	for a pulse frequency of 2.5 kHz	for a pulse frequency of 4 kHz
6SL3320- ...	kW (HP)	A		
DC link voltage 510 V to 720 V DC				
1TE32-1AA0	110 (150)	210	0.95	0.82
1TE32-6AA0	132 (200)	260	0.95	0.83
1TE33-1AA0	160 (250)	310	0.97	0.88
1TE33-8AA0	200 (300)	380	0.96	0.87
1TE33-0AA0	250 (400)	490	0.94	0.78

Derating factor of the output current as a function of the pulse frequency for devices with a rated pulse frequency of 1.25 kHz

Single Motor Module in chassis format	Output	Output current	Derating factor	
Type		for a pulse frequency of 1.25 kHz	for a pulse frequency of 2.5 kHz	
6SL3320- ...	kW (HP)	A		
DC link voltage 510 V to 720 V DC				
1TE36-1AA0	315 (500)	605	0.72	
1TE37-5AA0	400 (600)	745	0.72	
1TE38-4AA0	450 (700)	840	0.79	
1TE41-0AA0	560 (800)	985	0.87	
1TE41-2AA0	710 (1000)	1260	0.87	
1TE41-4AA0	800 (1150)	1405	0.95	

DC link voltage 890 V to 1035 V DC

1TH28-5AA0	75	85	0.89	
1TH31-0AA0	90	100	0.88	
1TH31-2AA0	110	120	0.88	
1TH31-5AA0	132	150	0.84	
1TH31-8AA0	160	175	0.87	
1TH32-2AA0	200	215	0.87	
1TH32-6AA0	250	260	0.88	
1TH33-3AA0	315	330	0.82	
1TH34-1AA0	400	410	0.82	
1TH34-7AA0	450	465	0.87	
1TH35-8AA0	560	575	0.85	
1TH37-4AA0	710	735	0.79	
1TH38-1AA0	800	810	0.95	
1TH38-8AA0	900	910	0.87	
1TH41-0AA0	1000	1025	0.86	
1TH41-3AA0	1200	1270	0.79	

Characteristics (continued)

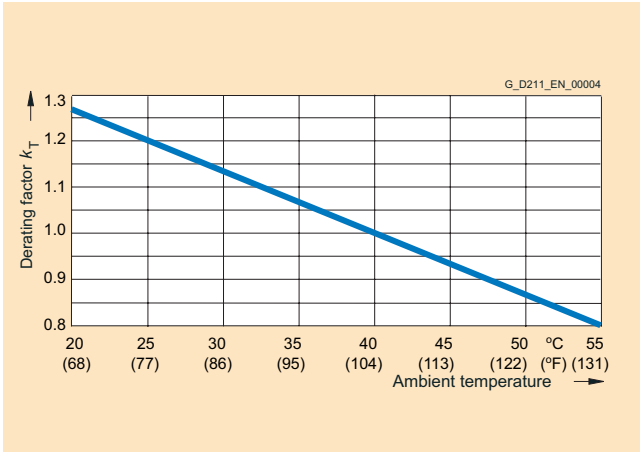

Current derating dependent on ambient temperature

Note: A derating factor $k_T > 1.0$ is to be taken into account only in conjunction with "current derating dependent on installation altitude". See also System description.

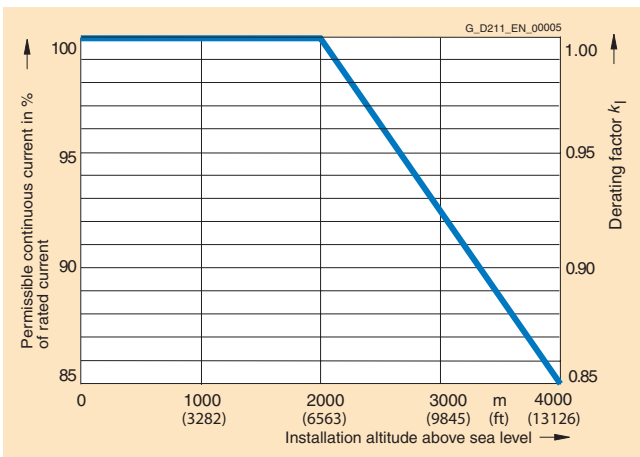

Current derating dependent on installation altitude

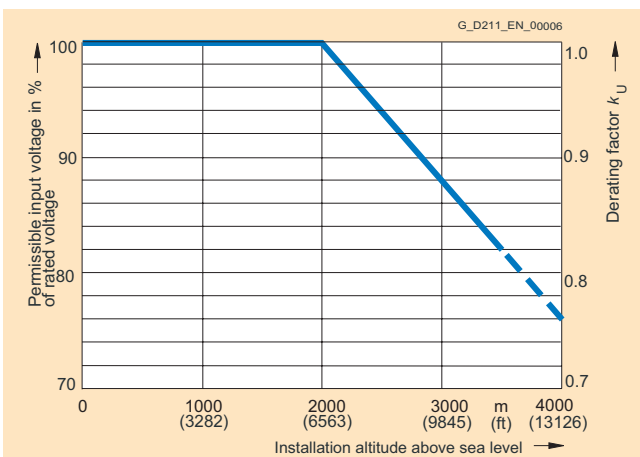

Voltage derating dependent on installation altitude

SINAMICS S120

Motor Modules

Double Motor Modules in booksize format

Design



Double Motor Modules feature the following interfaces as standard:

- 2 DC link connections via integrated DC link busbars
- 2 electronics power supply connections via integrated 24 V DC bars
- 4 DRIVE-CLiQ sockets
- 2 plug-in motor connections (not included in scope of supply)
- 2 safe standstill inputs (1 input per axis)
- 2 safe motor brake control
- 2 temperature sensor inputs (KTY84-130 or PTC)
- 3 PE (protective earth) connections

The status of the Motor Modules is indicated via two multi-color LEDs.

On Double Motor Modules, the motor cable shield can be connected in the connector.

The signal cable shield can be connected to the Motor Module by means of a shield connection terminal, e.g. type KLBÜ 3-8 SC by Weidmüller.

The scope of supply of the Motor Modules includes:

- DRIVE-CLiQ cable (length depends on module width) to connect Motor Module to adjacent module
- Jumper for connecting the 24 V DC busbar to the adjacent Motor Module
- Connectors X21 and X22

Integration

The Double Motor Module communicates with the CU320 or SIMOTION D Control Unit via DRIVE-CLiQ.

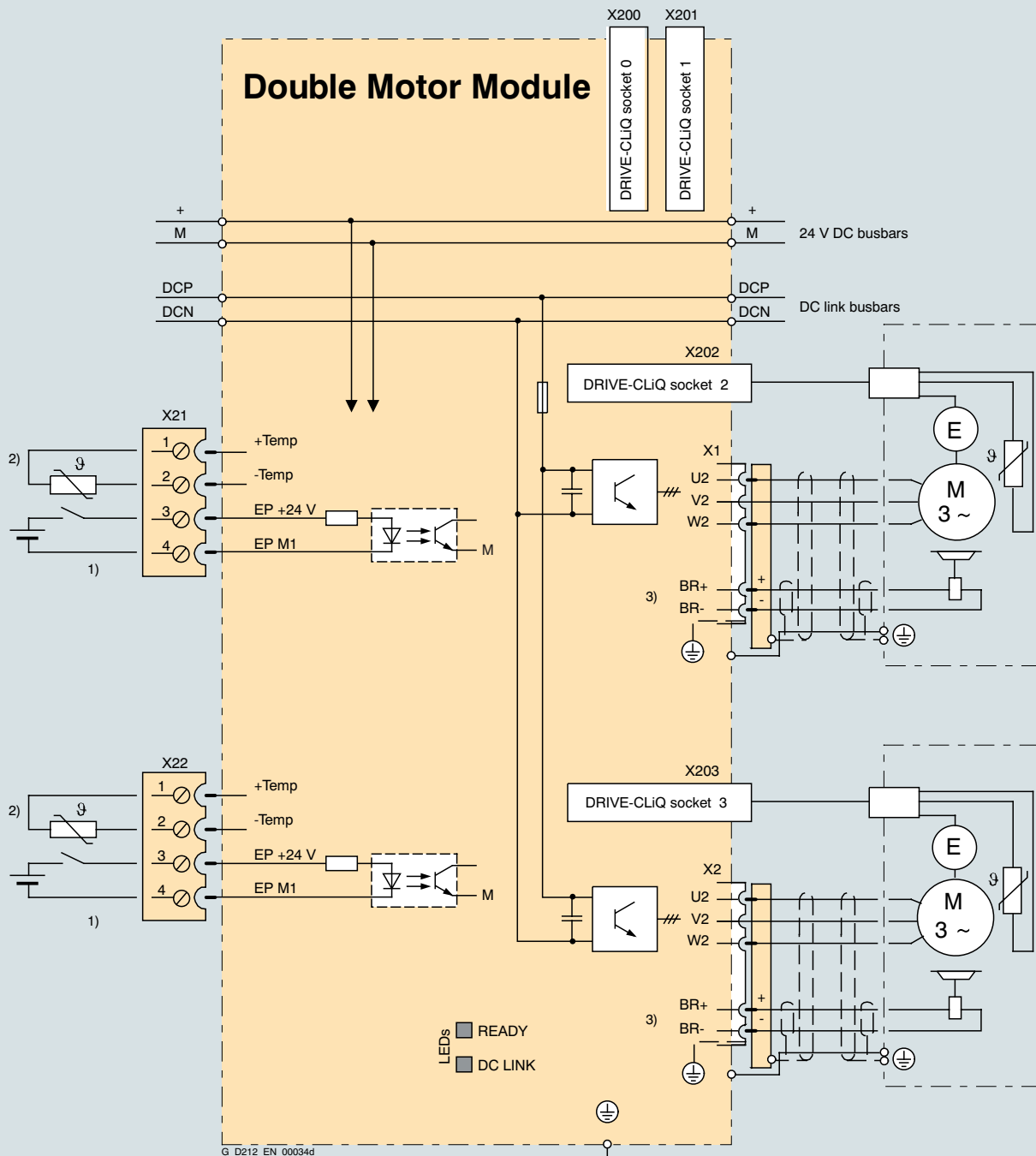

- 1) Required for Safety.
 2) Temperature sensor terminal for motors without DRIVE-CLiQ interface.
 3) The braking signal has an integrated overvoltage protection.
 An external circuit of the holding brake is not necessary.

Connection example of Double Motor Modules 2 × 3 A to 2 × 18 A

SINAMICS S120

Motor Modules

Double Motor Modules in booksize format

Technical data

General technical data

Electrical data	
DC link voltage (up to 2000 m (6563 ft) above sea level)	510 V to 720 V DC (line connection voltage 380 V to 480 V 3 AC)
Max. output voltage, line-to-line (fundamental-wave RMS value)	0.67 x DC with voltage
Output frequency	
• Control type Servo	0 Hz to 650 Hz ¹⁾
• Control type Vector	0 Hz to 300 Hz ¹⁾
• Control type V/f	0 Hz to 300 Hz ¹⁾
Electronics power supply	24 V DC – 15%/+ 20%
Radio interference suppression	
• Standard	No radio interference suppression
• in combination with Line Module incl. line filter and line reactor	Class A1 to EN 55011 and Category C2 to EN 61800-3
Ambient conditions	
Type of cooling	- Internal/external air cooling, power units with increased air cooling by means of built-in fan - Cold-plate cooling on request
Permissible ambient and coolant temperature (air) during operation for line-side components, Line Modules and Motor Modules	0 °C to + 40 °C (32 °F to + 104 °F) without derating, > 40 °C to + 55 °C (> 104 °F to +131 °F) see derating characteristics
Site altitude	Up to 1000 m (1328 ft) above sea level without derating, > 1000 m to 4000 m (13126 ft) above sea level see derating characteristics
Certificates	
Conformity	CE (low-voltage and EMC Directives)
Approvals	cULus (File No.: E192450)
Certification	Safety Integrity Level 2 (SIL 2) to IEC 61508, control category 3 to EN 954-1 for Safety Integrated – safe standstill (STO = Safe Torque Off) and safe brake control (SBC = Safe Brake Control)

¹⁾ Note correlation between max. output frequency, pulse frequency and current derating, see System Description.

Technical data (continued)

DC link voltage 510 V to 720 V DC		Double Motor Module in booksize format			
Internal air cooling		6SL3120-2TE13-0AA0	6SL3120-2TE15-0AA0	6SL3120-2TE21-0AA0	6SL3120-2TE21-8AA0
Internal air cooling with varnished modules		6SL3120-2TE13-0AB0	6SL3120-2TE15-0AB0	6SL3120-2TE21-0AB0	6SL3120-2TE21-8AB0
External air cooling		6SL3121-2TE13-0AA0	6SL3121-2TE15-0AA0	6SL3121-2TE21-0AA0	6SL3121-2TE21-8AA0
Rated output current I_{rated}	A	2 × 3	2 × 5	2 × 9	2 × 18
Output current for S6 duty (40%) I_{S6}	A	2 × 3.5	2 × 6	2 × 10	2 × 24
Base load current I_H	A	2 × 2.6	2 × 4.3	2 × 7.7	2 × 15.3
Max. output current I_{max}	A	2 × 6	2 × 10	2 × 18	2 × 36
Rated power for 600 V DC link voltage	kW (HP)	2 × 1.6 (2 × 1.5)	2 × 2.7 (2 × 3)	2 × 4.8 (2 × 5)	2 × 9.7 (2 × 10)
Rated power based on I_H	kW (HP)	2 × 1.4 (2 × 1)	2 × 2.3 (2 × 2.5)	2 × 4.1 (2 × 5)	2 × 8.2 (2 × 10)
DC link current $I_d^{1)}$	A	7.2	12	22	43
DC link busbar current capacity	A	100	100	100	100
DC link capacitance	μF	110	220	220	710
Max. current requirement at 24 V DC	A	1.0	1.0	1.0	1.0
24 V DC busbar current capacity	A	20	20	20	20
If, due to a number of Line and Motor Modules being mounted side-by-side, the current carrying capacity exceeds 20 A, an additional 24-V-DC connection using a 24-V terminal adapter is required (max. cross section 6 mm ² , max. fuse protection 20 A).					
Efficiency η		0.97	0.97	0.97	0.97
Power loss with internal air cooling in control cabinet	kW	0.07	0.105	0.16	0.32
Power loss with external air cooling int./ext.	kW	0.025/0.035	0.045/0.06	0.065/0.095	0.08/0.24
Cooling air requirement	m ³ /s (ft ³ /s)	0.008 (0.283)	0.008 (0.283)	0.008 (0.283)	0.016 (0.565)
Sound pressure level	dB(A)	< 60	< 60	< 60	< 60
Motor connection U2, V2, W2		2 x plug-in connectors (X1, X2), max. 30 A (not included in scope of supply, see Accessories)	2 x plug-in connectors (X1, X2), max. 30 A (not included in scope of supply, see Accessories)	2 x plug-in connectors (X1, X2), max. 30 A (not included in scope of supply, see Accessories)	2 x plug-in connectors (X1, X2), max. 30 A (not included in scope of supply, see Accessories)
Shield connection		integrated in connector (X1, X2)	integrated in connector (X1, X2)	integrated in connector (X1, X2)	integrated in connector (X1, X2)
PE connection		On housing with M5 screw	On housing with M5 screw	On housing with M5 screw	On housing with M5 screw
Motor brake connection		Integrated into the plug-in motor connector (X1, X2), DC 24 V, 2 A	Integrated into the plug-in motor connector (X1, X2), DC 24 V, 2 A	Integrated into the plug-in motor connector (X1, X2), DC 24 V, 2 A	Integrated into the plug-in motor connector (X1, X2), DC 24 V, 2 A
Max. motor cable length	m (ft)	50 (164) shielded 75 (246) unshielded	50 (164) shielded 75 (246) unshielded	50 (164) shielded 75 (246) unshielded	50 (164) shielded 75 (246) unshielded
Degree of protection		IP20	IP20	IP20	IP20
Width	mm (inch)	50 (1.97)	50 (1.97)	50 (1.97)	100 (3.94)
Height	mm (inch)	380 (14.96)	380 (14.96)	380 (14.96)	380 (14.96)
Depth with internal air cooling	mm (inch)	270 (10.63)	270 (10.63)	270 (10.63)	270 (10.63)
Depth with external air cooling on/behind mounting surface	mm (inch)	226/66.5 (8.9/2.6)	226/66.5 (8.9/2.6)	226/66.5 (8.9/2.6)	226/66.5 (8.9/2.6)
Approx. weight with internal air cooling	kg (lb)	5.3 (12)	5.3 (12)	5.3 (12)	6.8 (15)
Approx. weight with external air cooling	kg (lb)	5.8 (13)	5.8 (13)	5.8 (13)	8.6 (19)

¹⁾ Rated DC link current for dimensioning an external DC connection.
For DC link current calculation for dimensioning the Line Module, see System Description.

SINAMICS S120

Motor Modules

Double Motor Modules in booksize format

Selection and ordering data

Rated output current	Rated power	Double Motor Module in booksize format		
		Internal air cooling	Internal air cooling with varnished modules	External air cooling
A	kW (HP) ¹⁾	Order No.	Order No.	Order No.
DC link voltage 510 V to 720 V DC				
2 x 3 A	2 x 1.6 (2 x 1.5)	6SL3120-2TE13-0AA0	6SL3120-2TE13-0AB0	6SL3121-2TE13-0AA0
2 x 5 A	2 x 2.7 (2 x 3)	6SL3120-2TE15-0AA0	6SL3120-2TE15-0AB0	6SL3121-2TE15-0AA0
2 x 9 A	2 x 4.8 (2 x 5)	6SL3120-2TE21-0AA0	6SL3120-2TE21-0AB0	6SL3121-2TE21-0AA0
2 x 18 A	2 x 9.7 (2 x 10)	6SL3120-2TE21-8AA0	6SL3120-2TE21-8AB0	6SL3121-2TE21-8AA0

Accessories

Description	Order No.
Power connector (X1/X2) at Motor Module end, with screw-type terminals 1.5 mm ² to 10 mm ² , for Motor Modules with a rated output current of 3 to 30 A	6SL3162-2MA00-0AA0
DC link supply adapter for direct infeed of DC link voltage Screw-type terminals 0.5 mm ² to 10 mm ² for booksize format Line/Motor Modules with a width of 50 mm (1.97 in) or 100 mm (3.94 in)	6SL3162-2BD00-0AA0
DC link adapters (2x) for multi-tier configuration Screw-type terminals 35 mm ² to 95 mm ² for all Line Modules/Motor Modules in booksize format	6SL3162-2BM01-0AA0
24 V terminal adapter for all Line Modules/Motor Modules in booksize format	6SL3162-2AA00-0AA0
24 V jumper for connection of the 24 V busbars (for booksize format)	6SL3162-2AA01-0AA0
Warning signs in foreign languages This set of foreign language warning signs can be placed on top of the standard German or English signs. One sign in each of the following languages is provided in each set: Chinese, Danish, Dutch, Finnish, French, Greek, Italian, Japanese, Korean, Portuguese, Spanish and Swedish.	6SL3166-3AB00-0AA0

¹⁾ Nominal HP based on Asynchronous motors (induction motors).
Match the motor nameplate current for specific sizing.

Characteristics

Overload capability

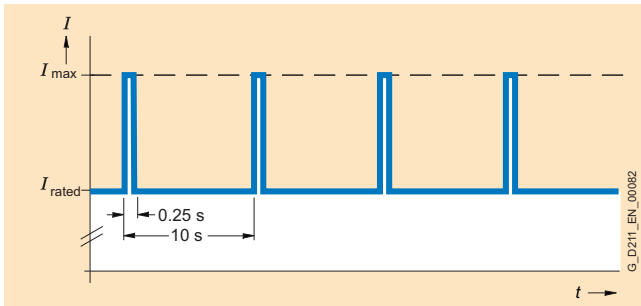

Load cycle with previous load

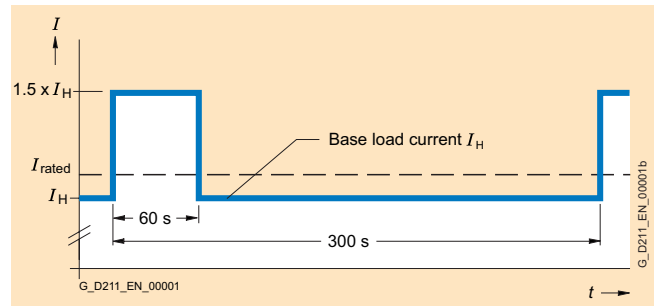

Load cycle with 60 s overload with a load cycle period of 300 s

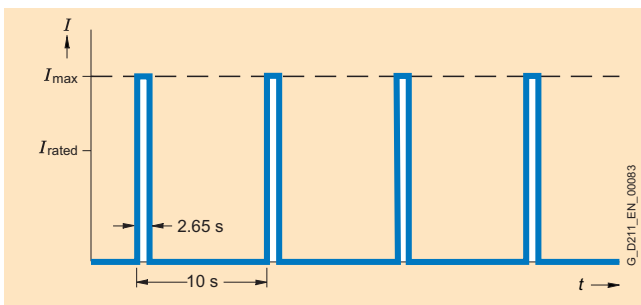

Load cycle without previous load

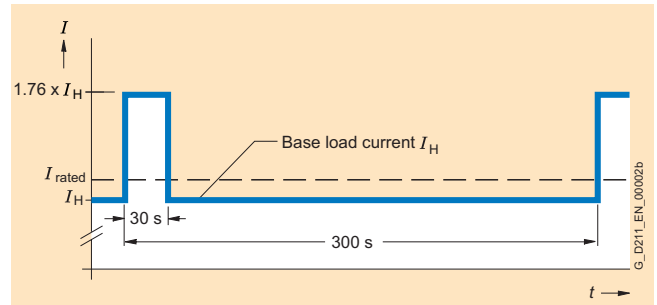

Load cycle with 30 s overload with a load cycle period of 300 s

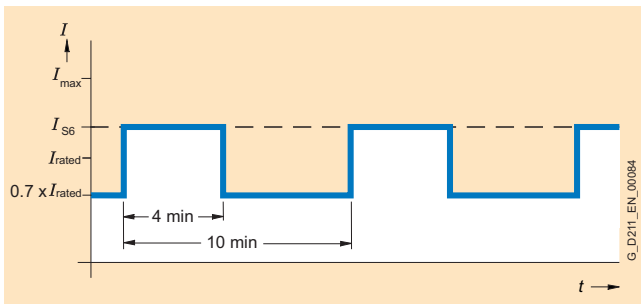

S6 load cycle with previous load with a load cycle period of 600 s

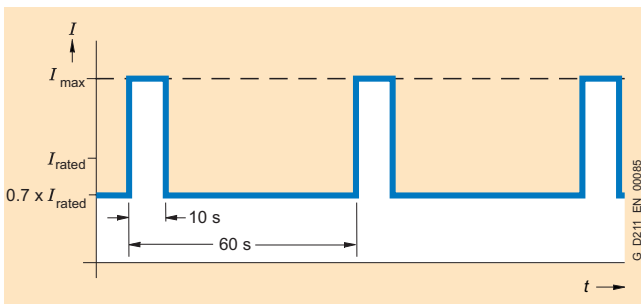

S6 load cycle with previous load with a load cycle period of 60 s

Double Motor Modules in booksize format

Characteristics (continued)

Derating characteristics

2

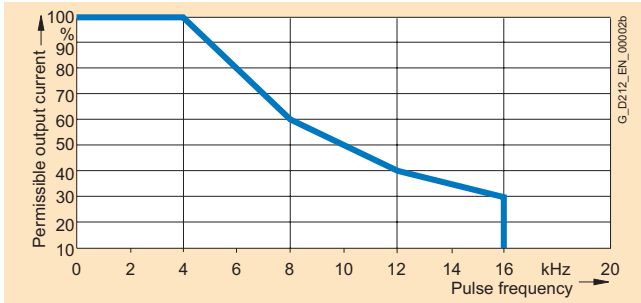

Output current dependent on pulse frequency

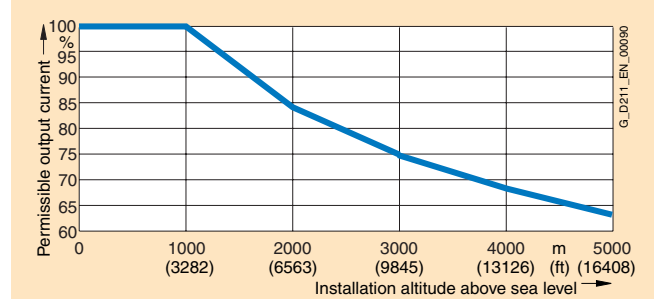

Output current dependent on installation altitude

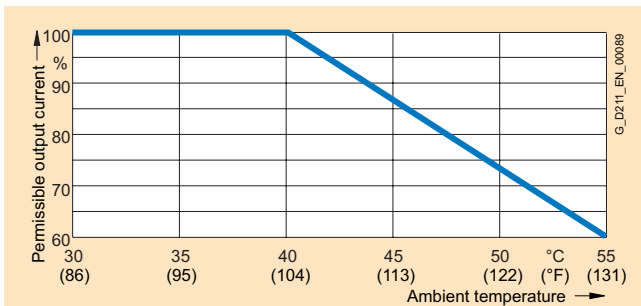

Output current dependent on ambient temperature

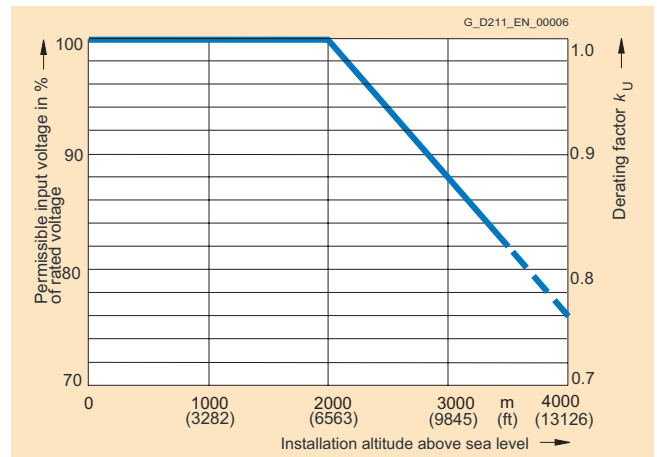

Voltage derating dependent on installation altitude

Overview



A Braking Module and the matching external braking resistor are required to bring drives to a controlled standstill in the event of a power failure (e.g. emergency retraction or EMERGENCY OFF category 1) or limit the DC link voltage for brief periods of generator operation, e.g. when the regenerative feedback capability of the Line Module is deactivated. The Braking Module houses the power electronics and the associated control circuit. During operation, the DC link energy is converted to heat loss in an external braking resistor. Braking Modules function autonomously. A number of braking modules can be operated in parallel. In this case, each Braking Module must have its own braking resistor.

Braking Modules in booksize format can also be used for rapid discharge of the DC link.

Design

The Braking Module in booksize format features the following interfaces as standard:

- 2 DC link connections via integrated DC link busbars
- 2 electronics power supply connections via integrated 24 V DC bars
- Terminals for connecting the braking resistor
- 2 digital inputs (disable Braking Module/acknowledge faults and rapid discharge of DC link)
- 2 digital outputs (Braking Module disabled and prewarning – Δt monitoring)
- 2 PE (protective earth) connections

The status of the Braking Module is indicated via two 2-color LEDs.

Selection and ordering data

Description	Order No.
DC link voltage 510 V to 720 V DC	
Braking Module in booksize format (varnished) 1.5 kW/100 kW	6SL3100-1AE31-0AB0

Accessories

Description	Order No.
Warning signs in foreign languages	6SL3166-3AB00-0AA0
This set of foreign language warning signs can be placed on top of the standard German or English signs. One sign in each of the following languages is provided in each set: Chinese, Danish, Dutch, Finnish, French, Greek, Italian, Japanese, Korean, Portuguese, Spanish and Swedish.	

SINAMICS S120

DC link components

Braking Modules in booksize format

Integration

2

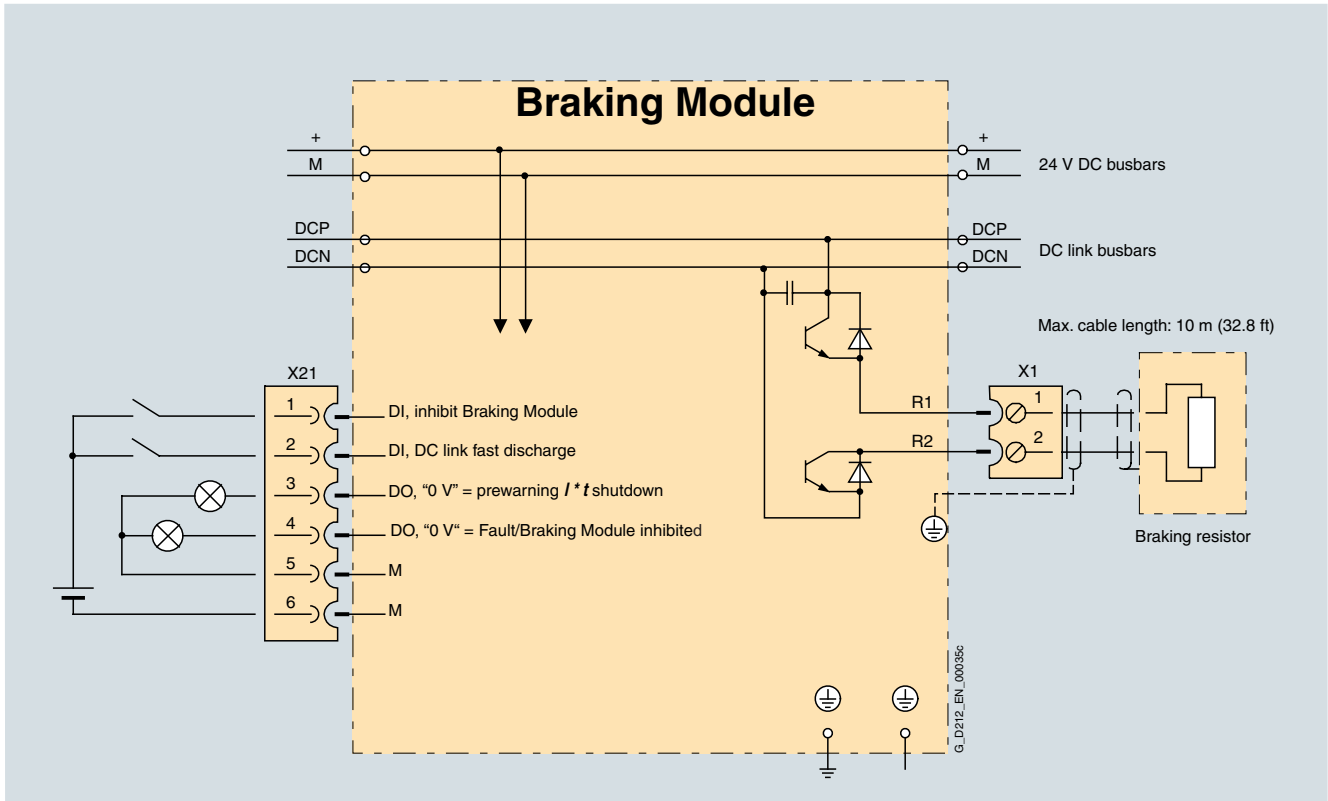

Connection example of Braking Module in booksize format

Technical data

DC link voltage 510 V to 720 V DC	Braking Module in booksize format (varnished)
Rated power P_{DB}	1.5 kW
Peak power P_{max}	100 kW
Activation threshold	770 V
Max. permissible cable length to braking resistor	10 m (32.8 ft)
DC link capacitance	110 μ F
Max. current requirements at 24 V DC	0.5 A
Digital inputs	
• Voltage	- 3 V to + 30 V
• Low level (an open digital input is interpreted as "low")	- 3 V to + 5 V
• High level	15 V to 30 V
• Current consumption (typ. at 24 V DC)	10 mA
• Max. connectable cross section	1.5 mm ²
Digital outputs (continued-short-circuit-proof)	
• Voltage	24 V DC
• Max. load current per digital output	100 mA
• Max. connectable cross section	1.5 mm ²
24 V DC busbar current capacity	20 A
DC link busbar current capacity	100 A
PE connection	On housing with M5 screw
Width	50 mm (1.97 in)
Height	380 mm (14.96 in)
Depth, with spacer (included in scope of supply)	270 mm (10.63 in)
Weight, approx.	4.1 kg (9 lb)

Overview

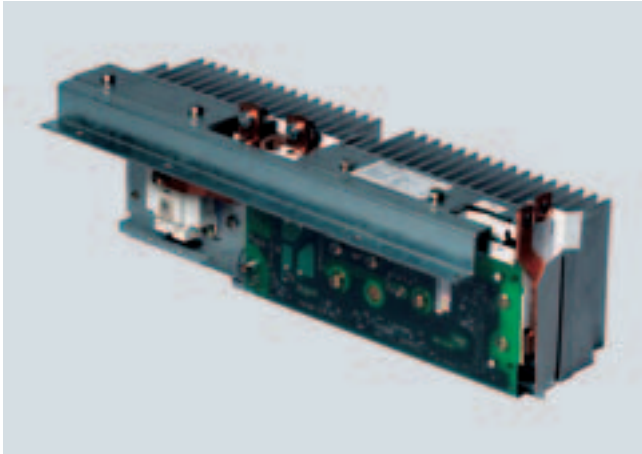

A Braking Module and the matching external braking resistor are required to bring drives to a controlled standstill in the event of a power failure (e.g. emergency retraction or EMERGENCY OFF category 1) or limit the DC link voltage for brief periods of generator operation, e.g. when the regenerative feedback capability of the Line Module is deactivated. The Braking Module houses the power electronics and the associated control circuit. During operation, the DC link energy is converted to power loss in an external braking resistor. Braking Modules function autonomously. A number of braking modules can be operated in parallel. In this case, each Braking Module must have its own braking resistor.

The Braking Module in chassis format is inserted in a mounting location inside the Motor Module, Line Module or Power Module and is force cooled by the fan. The supply voltage for the electronics is drawn from the DC link. The Braking Module is connected to the DC link by means of the busbar sets and flexible cables, which are supplied as standard.

The activation threshold of the Braking Module can be adjusted by means of a DIP switch. The braking power values specified in the technical data apply to the upper activation threshold.

Design

The Braking Modules in chassis format feature the following interfaces as standard:

- 1 DC link connection
- 1 braking resistor connection
- 1 digital input (inhibit Braking Module/acknowledge error)
- 1 digital output (Braking Module inhibited)
- 1 DIP switch for adjusting the application threshold

Selection and ordering data

Description	Order No.
DC link voltage 510 V to 720 V DC	
Braking Module in chassis format	
• Frame size FX, 25 kW/125 kW	6SL3300-1AE31-3AA0
• Frame size GX, 50 kW/250 kW	6SL3300-1AE32-5AA0
• Frame sizes HX and JX, 50 kW/250 kW	6SL3300-1AE32-5BA0
DC link voltage 890 V to 1035 V DC	
Braking Module in chassis format	
• Frame size FX, 25 kW/125 kW	6SL3300-1AH31-3AA0
• Frame size GX, 50 kW/250 kW	6SL3300-1AH32-5AA0
• Frame sizes HX and JX, 50 kW/250 kW	6SL3300-1AH32-5BA0

Warning signs in foreign languages

Warning signs in other languages can be placed on top of the standard warning signs in German or English.

The following signs are supplied with chassis format units: Chinese, Danish, Finnish, French, Greek, Italian, Japanese, Korean, Dutch, Polish, Portuguese, Russian, Swedish, Spanish, Czech and Turkish.

Accessories

Description	Order No.
Cable harness set for mounting of Braking Modules frame size GX into a Basic Line Module frame size GB	6SL3366-2NG00-0AA0

Braking Modules in chassis format

Integration

2

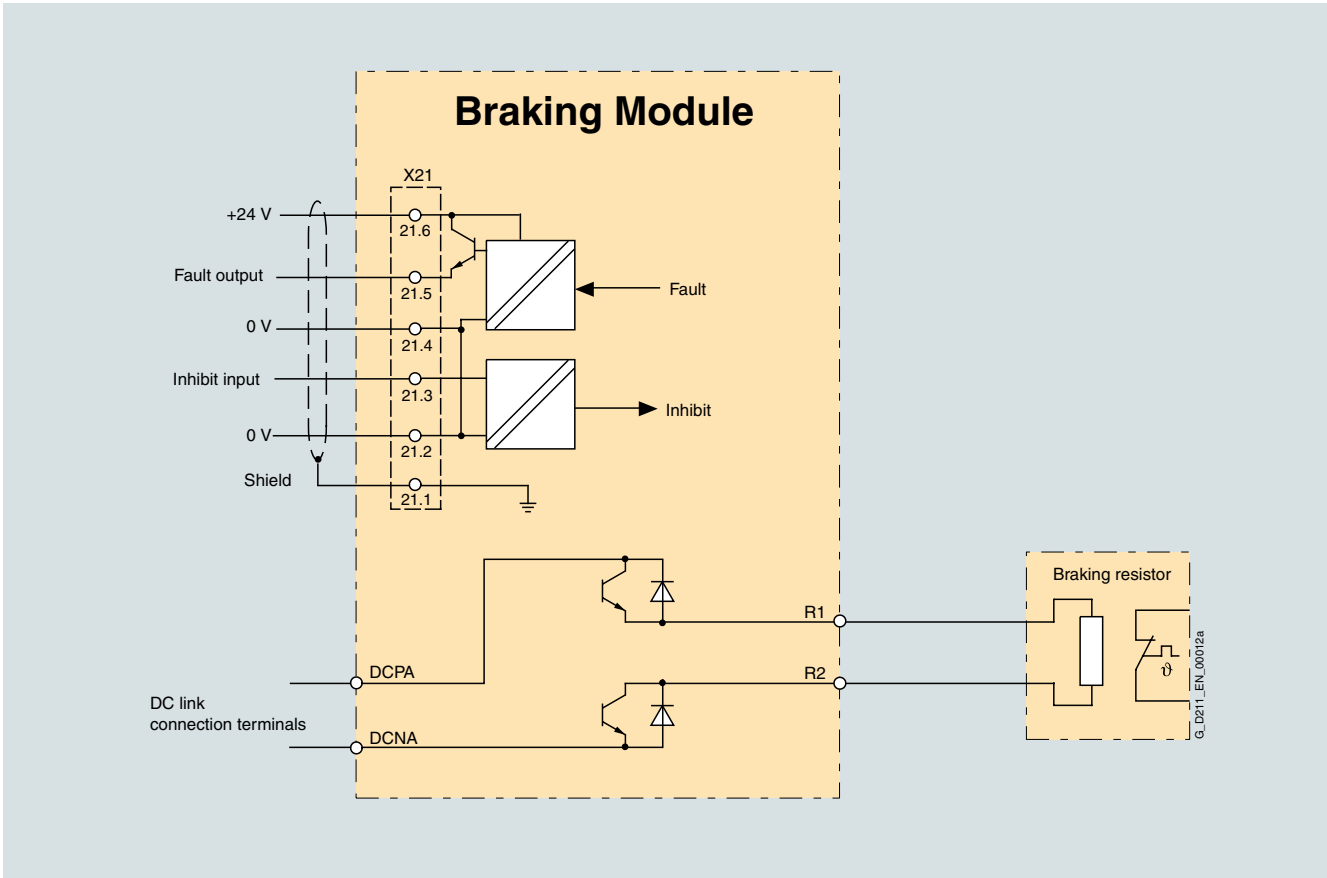

Connection example of Braking Module in chassis format

Technical data

DC link voltage 510 V to 720 V DC	Braking Module in chassis format			
		6SL3300-1AE31-3AA0	6SL3300-1AE32-5AA0	6SL3300-1AE32-5BA0
P_{DB} rated power	kW	25	50	50
P_{15} peak power	kW	125	250	250
P_{20} power	kW	100	200	200
P_{40} power	kW	50	100	100
Activation thresholds (adjustable via DIP switch)	V	774 (factory setting) or 673	774 (factory setting) or 673	774 (factory setting) or 673
Max. permissible cable length to braking resistor	m (ft)	50 (164)	50 (164)	50 (164)
Digital inputs				
• Voltage	V	-3 to +30	-3 to +30	-3 to +30
• Low level (an open digital input is interpreted as "low")	V	-3 to +5	-3 to +5	-3 to +5
• High level	V	15 to 30	15 to 30	15 to 30
• Current consumption (typ. at 24 V DC)	mA	10	10	10
• Max. connectable cross section	mm ²	1.5	1.5	1.5
Digital outputs (continued-short-circuit-proof)				
• Voltage	V	DC 24	DC 24	DC 24
• Max. load current per digital output	mA	500	500	500
• Max. connectable cross section	mm ²	1.5	1.5	1.5
Terminal/screw R1/R2		M8	M8	M8
Max. connectable cross section R1/R2	mm ²	35	50	50
Weight, approx.	kg (lb)	3.6 (8)	7.3 (16)	7.5 (17)
Suitable for installation in a Moto Module/Active Line Module/Basic Line Module frame size	Frame size	FX/FB	GX/GB ¹⁾	HX/JX

DC link voltage 890 V to 1035 V DC	Braking Module in chassis format			
		6SL3300-1AH31-3AA0	6SL3300-1AH32-5AA0	6SL3300-1AH32-5BA0
P_{DB} rated power	kW	25	50	50
P_{15} peak power	kW	125	250	250
P_{20} power	kW	100	200	200
P_{40} power	kW	50	100	100
Activation thresholds (adjustable via DIP switch)	V	1153 (factory setting) or 1070	1153 (factory setting) or 1070	1153 (factory setting) or 1070
Max. permissible cable length to braking resistor	m (ft)	50 (164)	50 (164)	50 (164)
Digital inputs				
• Voltage	V	-3 to +30	-3 to +30	-3 to +30
• Low level (an open digital input is interpreted as "low")	V	-3 to +5	-3 to +5	-3 to +5
• High level	V	15 to 30	15 to 30	15 to 30
• Current consumption (typ. at 24 V DC)	mA	10	10	10
• Max. connectable cross section	mm ²	1.5	1.5	1.5
Digital outputs (continued-short-circuit-proof)				
• Voltage	V	DC 24	DC 24	DC 24
• Max. load current per digital output	mA	500	500	500
• Max. connectable cross section	mm ²	1.5	1.5	1.5
Terminal/screw R1/R2		M8	M8	M8
Max. connectable cross section R1/R2	mm ²	35	50	50
Weight, approx.	kg (lb)	3.6 (8)	7.3 (16)	7.5 (17)
Suitable for installation in a Motor Module/Active Line Module/Basic Line Module frame size	Frame size	FX/FB	GX/GB ¹⁾	HX/JX

¹⁾ Cable harness set 6SL3366-2NG00-0AA0 is required to connect the Braking Module to a Basic Line Module of frame size GB.

SINAMICS S120

DC link components

Braking resistors for blocksize format

Overview



Braking resistor for blocksize format, frame sizes FSA and FSC

The PM340 Power Modules cannot regenerate into the line supply. For regenerative operation, e.g. the braking of a rotating mass, a braking resistor must be connected to convert the resulting energy into heat.

The braking resistor is connected at terminals DCP/R1 and R2.

The braking resistors can be installed at the side next to the PM340 Power Modules. The braking resistors for the FSA and FSB frame sizes are designed as base components. If the PM340 Power Modules of the FSA or FSB frame size are operated without line reactor, the braking resistors can also be installed under the Power Modules.

The braking resistors for the Power Modules of the FSC to FSF frame sizes should be placed outside the control cabinet or the switchgear room in order to direct the resulting heat loss away from the Power Modules, thereby allowing a corresponding reduction in the level of air conditioning required.

The braking resistors are designed with a temperature switch. The temperature switch must be evaluated to prevent consequential damage if the braking resistor overheats.

Selection and ordering data

Description	Suitable for Power Module, blocksize format	Order No.
DC link voltage 240 V to 360 V DC (line voltage 200 V to 240 V 1 AC)		
Braking resistor		
• 180 ohm	Frame size FSA	6SE6400-4BC05-0AA0
DC link voltage 510 V to 720 V DC (line voltage 380 V to 480 V 3 AC)		
Braking resistor		
• 390 ohm	Frame size FSA	6SE6400-4BD11-0AA0
• 160 ohm	Frame size FSB	6SL3201-0BE12-0AA0
• 56 ohm	Frame size FSC	6SE6400-4BD16-5CA0
• 27 ohm	Frame size FSD	6SE6400-4BD21-2DA0
• 15 ohm	Frame size FSE	6SE6400-4BD22-2EA0
• 8.2 ohm	Frame size FSF	6SE6400-4BD24-0FA0

Characteristics

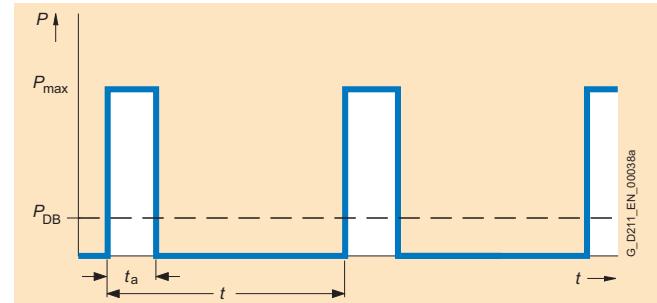

Load diagram for braking resistors in blocksize format

$$t_a = 12 \text{ s}$$

$$t = 240 \text{ s}$$

G_D211_EN_00038a

Technical data

DC link voltage 240 V to 360 V DC		Braking resistor for Power Modules in blocksize format 6SE6400-4BC05-0AA0	
Resistor		180 ohm	
Rated power P_{DB}		0.05 kW	
Peak power P_{max}		1 kW	
Degree of protection ¹⁾		IP20	
Power connections		3 × 1.5 mm ² (shielded) length 0.5 m (1.64 ft)	
Thermostatic switch (NC contact)			
• Switching capacity		250 V AC/max. 2.5 A	
• Connectable cable cross section		0.5 mm ² to 2.5 mm ²	
Width		72 mm (2.83 in)	
Height		230 mm (9.05 in)	
Depth		43.5 mm (1.71 in)	
Weight, approx.		1.0 kg (2)	

DC link voltage 510 V to 720 V DC		Braking resistors for Power Modules in blocksize format						
		6SE6400-4BD11-0AA0	6SL3201-0BE12-0AA0	6SE6400-4BD16-5CA0	6SE6400-4BD21-2DA0	6SE6400-4BD22-2EA0	6SE6400-4BD24-0FA0	
Resistor	Ohm	390	160	56	27	15	8.2	
Rated power P_{DB}	kW	0.1	0.2	0.65	1.2	2.2	4.0	
Peak power P_{max}	kW	1.7	4.1	12	24	44	80	
Degree of protection ¹⁾		IP20	IP20	IP20	IP20	IP20	IP20	
Power connections		3 × 1.5 mm ² (shielded) length 0.5 m (1.64 ft)	3 × 1.5 mm ² (shielded) length 0.5 m (1.64 ft)	3 × 1.5 mm ² (shielded) length 0.9 m (2.95 ft)	M6 screw studs	M6 screw studs	M6 screw studs	
Thermostatic switch (NC contact)								
• Switching capacity		250 V AC/ max. 2.5 A	250 V AC/ max. 2.5 A	250 V AC/ max. 2.5 A	250 V AC/ max. 2.5 A	250 V AC/ max. 2.5 A	250 V AC/ max. 0.2 A	
• Connectable cable cross section		0.5 mm ² to 2.5 mm ²	0.5 mm ² to 2.5 mm ²	0.5 mm ² to 2.5 mm ²	0.5 mm ² to 2.5 mm ²	0.5 mm ² to 2.5 mm ²	0.5 mm ² to 2.5 mm ²	
Width	mm (inch)	72 (2.83)	153 (6.02)	185 (7.28)	270 (10.63)	270 (10.63)	400 (15.75)	
Height	mm (inch)	230 (9.05)	329 (12.95)	285 (11.22)	515 (20.28)	645 (25.39)	650 (25.59)	
Depth	mm (inch)	43.5 (1.71)	43.5 (1.71)	150 (5.9)	175 (6.89)	175 (6.89)	315 (12.4)	
Weight, approx.	kg (lb)	1.0 (2)	1.6 (3)	3.8 (8)	7.4 (16)	10.6 (23)	16.7 (37)	

¹⁾ With correctly connected load connection cable.

SINAMICS S120

DC link components

Braking resistors for booksize format

Overview



The excess energy of the DC link is dissipated via the braking resistor.

The braking resistor is connected to a Braking Module. The braking resistor is positioned outside the cabinet or switchgear room. This arrangement enables the resulting heat loss around the Line Modules / Motor Modules to be dissipated, thereby allowing a corresponding reduction in the level of air conditioning required.

2 braking resistors with different rated and peak power values are available for booksize format units.

Selection and ordering data

Description	Order No.
DC link voltage 510 V to 720 V DC	
Braking resistor	
• 0.3 kW/25 kW	6SN1113-1AA00-0DA0
• 1.5 kW/100 kW	6SL3100-1BE31-0AA0

Characteristics

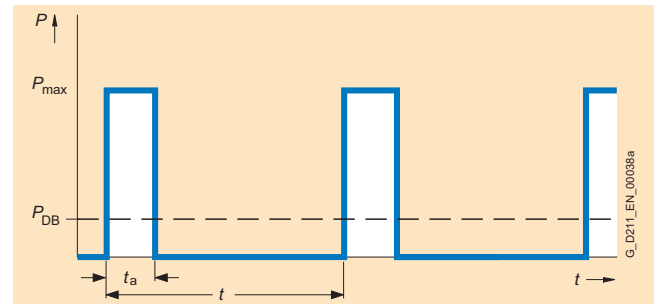

Load diagram for Braking Module and braking resistor in booksize format

The braking resistor is monitored on the basis of the mark-space ratio.

Technical data

DC link voltage 510 V to 720 V DC	Braking resistors for Braking Modules in booksize format					
		6SN1113-1AA00-0DA0		6SL3100-1BE31-0AA0		
Resistor	Ohm	17		5.7		
Rated power P_{DB}	kW	0.3		1.5		
Peak power P_{max}	kW	25		100		
In-service period for peak power t_a	s	0.1	0.4	1	2	
Period duration of braking duty cycle t	s	11.5	210	68	460	
Degree of protection		IP54 Braking resistor with connected 1.5 mm ² cable (shielded), 3 m (9.84 ft) long		IP20		
Width	mm (inch)	80 (3.15)		193 (7.6)		
Height	mm (inch)	210 (8.27)		410 (16.14)		
Depth	mm (inch)	53 (2.09)		240 (9.45)		
Weight, approx.	kg (lb)	3.4 (8)		5.6 (12)		

Overview

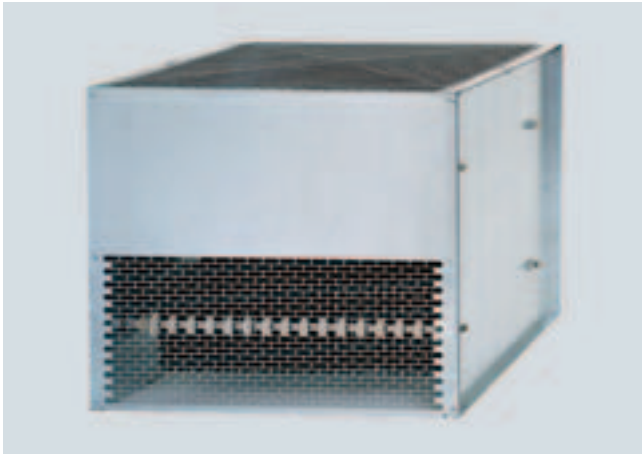

The excess energy of the DC link is dissipated via the braking resistor.

The braking resistor is connected to a Braking Module. The braking resistor is positioned outside the cabinet or switchgear room. This arrangement enables the resulting heat loss around the Line Modules / Motor Modules to be dissipated, thereby allowing a corresponding reduction in the level of air conditioning required.

2 braking resistors with different rated and peak power values are available for chassis format units.

The braking resistor is monitored on the basis of the mark-space ratio. A temperature switch (NC contact) is also fitted. This responds when the maximum permissible temperature is exceeded and can be evaluated by a controller.

Technical data

DC link voltage 510 V to 720 V DC		Braking resistors for Braking Modules in chassis format	
		6SL3000-1BE31-3AA0	6SL3000-1BE32-5AA0
Resistor	Ohm	4.4	2.2
Rated power P_{DB}	kW	25	50
Peak power P_{max}	kW	125	250
In-service period for peak power	s	15	15
Period duration of braking duty cycle	s	90	90
Max. current	A	189	378
Cable entry		via M50 cable gland	via M50 cable gland
Power connection		via M10 stud terminal	via M10 stud terminal
Max. connectable cross section	mm ²	50	70
Degree of protection		IP20	IP20
Width	mm (inch)	740 (29.13)	810 (31.89)
Height	mm (inch)	605 (23.82)	1325 (52.17)
Depth	mm (inch)	485 (19.09)	485 (19.09)
Weight, approx.	kg (lb)	50 (110)	120 (265)

DC link voltage 890 V to 1035 V DC		Braking resistors for Braking Modules in chassis format	
		6SL3000-1BH31-3AA0	6SL3000-1BH32-5AA0
Resistor	Ohm	9.8	4.9
Rated power P_{DB}	kW	25	50
Peak power P_{max}	kW	125	250
In-service period for peak power	s	15	15
Period duration of braking duty cycle	s	90	90
Max. current	A	125	255
Cable entry		via M50 cable gland	via M50 cable gland
Power connection		via M10 stud terminal	via M10 stud terminal
Max. connectable cross section	mm ²	50	70
Degree of protection		IP20	IP20
Width	mm (inch)	740 (29.13)	810 (31.89)
Height	mm (inch)	605 (23.82)	1325 (52.17)
Depth	mm (inch)	485 (19.09)	485 (19.09)
Weight, approx.	kg (lb)	50 (110)	120 (265)

SINAMICS S120

DC link components

Braking resistors for chassis format

Selection and ordering data

Description	Suitable for Braking Module in chassis format	Order No.
DC link voltage 510 V to 720 V DC		
Braking resistor		
• 25 kW/125 kW	6SL3300-1AE31-3AA0	6SL3000-1BE31-3AA0
• 50 kW/250 kW	6SL3300-1AE32-5 . A0	6SL3000-1BE32-5AA0
DC link voltage 890 V to 1035 V DC		
Braking resistor		
• 25 kW/125 kW	6SL3300-1AH31-3AA0	6SL3000-1BH31-3AA0
• 50 kW/250 kW	6SL3300-1AH32-5 . A0	6SL3000-1BH32-5AA0

Characteristics

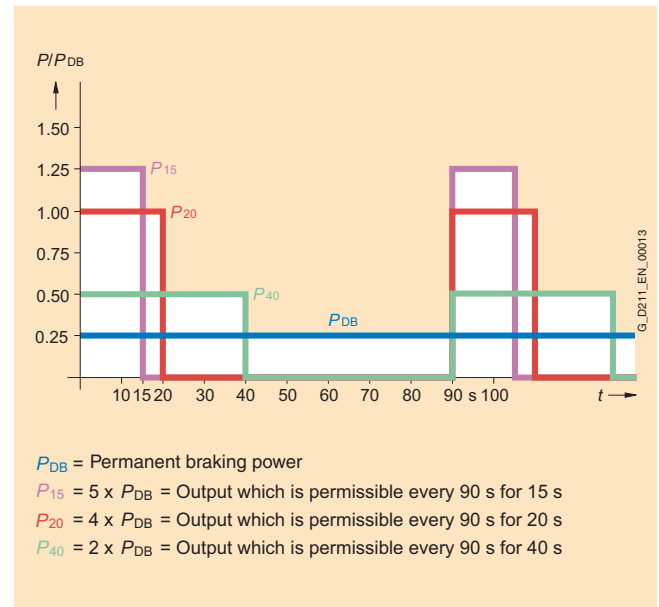

Load diagram for Braking Module and braking resistor in chassis format

Overview



Capacitor Modules are used to increase the DC link capacitance to bridge momentary power losses.

Capacitor Modules are connected to the DC link voltage via the integrated DC link busbars. Capacitor Modules function autonomously.

Several Capacitor Modules can be operated in parallel.

Design

Capacitor Modules feature the following interfaces as standard:

- 2 DC link connections via integrated DC link busbars
- 2 PE (protective earth) connections

Selection and ordering data

Description	Order No.
Capacitor Module in booksize format	6SL3100-1CE14-0AA0

Accessories

Description	Order No.
Warning signs in foreign languages	6SL3166-3AB00-0AA0
<p>This set of foreign language warning signs can be placed on top of the standard German or English signs. One sign in each of the following languages is provided in each set: Chinese, Danish, Dutch, Finnish, French, Greek, Italian, Japanese, Korean, Portuguese, Spanish and Swedish.</p>	

Technical data

DC link voltage 510 V to 720 V DC	Capacitor Module
Capacitance	4000 μ F
24 V DC busbar current capacity	20 A
DC link busbar current capacity	100 A
PE connection	On housing with M5 screw
Width	100 mm (3.94 in)
Height	380 mm (14.96 in)
Depth, with spacer (included in scope of supply)	270 mm (10.63 in)
Weight, approx.	7.2 kg (16 lb)

SINAMICS S120

DC link components

Control Supply Modules in booksize format

Overview



The Control Supply Module in booksize format provides a 24 V DC power supply via the line or DC link. This makes it possible, for example, to make emergency retraction movements in the event of a supply failure, provided that the DC link voltage is available.

Design

Control Supply Modules feature the following interfaces as standard:

- 1 power connection
- 2 DC link connections via integrated DC link busbars
- 2 electronics power supply connections via integrated 24 V DC bars
- 1 connection for the electronics power supply for Control Units, Terminal Modules, Sensor Modules, etc., via the 24 V terminal adapter provided in the scope of supply (max. cross section 6 mm², max. fuse protection 20 A)
- 2 PE (protective earth) connections

The status of the Control Supply Modules is indicated via two multi-color LEDs.

Selection and ordering data

Description	Order No.
Control Supply Module in booksize format	6SL3100-1DE22-0AA0

Accessories

Description	Order No.
Warning signs in foreign languages This set of foreign language warning signs can be placed on top of the standard German or English signs. One sign in each of the following languages is provided in each set: Chinese, Danish, Dutch, Finnish, French, Greek, Italian, Japanese, Korean, Portuguese, Spanish and Swedish.	6SL3166-3AB00-0AA0

Integration

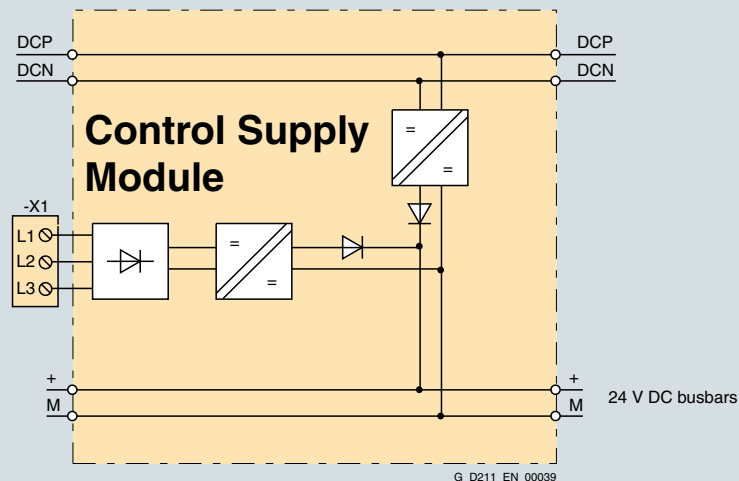

Connection example of Control Supply Module

Technical data

DC link voltage 510 V to 720 V DC Line voltage 380 V to 480 V 3 AC	Control Supply Module in booksize format
Rated input current	
• at 400 V 3 AC	2.2 A
• at 600 V DC	1.1 A
Radio interference suppression (standard)	Class A1 to EN 55011 and Category C2 to EN 61800-3
Rated output voltage	26 V DC
Rated output current	20 A
24 V DC busbar current capacity	20 A
DC link busbar current capacity	100 A
Power connection L1, L2, L3 (X1)	Screw-type terminals 0.2 mm ² to 4.0 mm ²
PE connection	On housing with M5 screw
Width	50 mm (1.97 in)
Height	380 mm (14.96 in)
Depth, with spacer (included in scope of supply)	270 mm (10.63 in)
Weight, approx.	4.8 kg (11 lb)

SINAMICS S120

DC link components

DC link supply adapter for booksize format

Overview

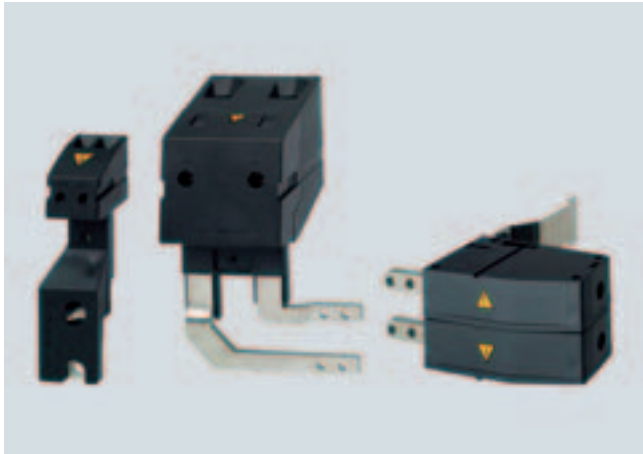

If the internal Motor Module DC link busbars are not to be used, the DC link voltage can be provided externally via a DC link power supply adapter. Two versions are available depending on cable cross section. The DC link power supply adapter is mounted on the DC link busbars of the Motor Module. The DC link cables are routed from above.

If a multi-tier Motor Module configuration is used, a DC link power supply adapter set can be provided for linking the DC links of two drive groups. The DC link power supply adapters are mounted on the DC link busbars of the Motor Modules to the far right of each group. The DC link cables are routed from behind.

Technical data

		DC link supply adapter for booksize format		
		6SL3162-2BD00-0AA0	6SL3162-2BM00-0AA0	6SL3162-2BM01-0AA0
Connectable cross section (screw-type terminals)	mm ²	0.5 to 10	35 to 95	35 to 95
Current carrying capacity	A	36	240	240
Weight, approx.	kg (lb)	0.06 (0.1)	0.48 (1.1)	0.76 (1.7)

Selection and ordering data

Description	Order No.
DC link supply adapter for direct infeed of DC link voltage for Line Modules and Motor Modules in booksize format • 50 mm (1.97 in) and 100 mm (3.94 in) wide • 150 mm (5.91 in), 200 mm (7.87 in) and 300 mm (11.81 in) wide	6SL3162-2BD00-0AA0 6SL3162-2BM00-0AA0
DC link adapters (2x) for multi-tier configuration for all Line Modules and Motor Modules in booksize format	6SL3162-2BM01-0AA0

Overview



Undesirable oscillations to ground potential can occur in drive groupings with total cable lengths (sum of all motor and DC link cables) of > 350 m (1148 ft) (shielded) or 560 m (1837 ft) (unshielded). The Voltage Clamping Module damps these oscillations, thereby allowing the total permissible cables lengths in a booksize format drive grouping to increase to 630 m (2067 ft) (shielded) or 850 m (2789 ft) (unshielded), taking derating into account (see characteristics of corresponding Line Modules).

With total cable lengths of > 350 m (1148 ft), the limit values of Category C2 defined in EN 61800-3 can be exceeded.

VCM Voltage Clamping Modules may be operated only in networks with grounded neutral (TN system).

Where possible, the Voltage Clamping Module should be mounted next to the Line Module and connected to the voltage-source DC link via the integrated DC busbar.

Design

The Voltage Clamping Module features the following interfaces as standard:

- 2 DC link connections via integrated DC link busbars
- 1 connection for HSB
- 2 PE (protective earth) connections

Technical data

DC link voltage 510 V to 720 V DC	Voltage Clamping Module in booksize format
24 V DC busbar current capacity	20 A
DC link busbar current capacity	100 A
PE connection	On housing with M5 screw
Grounding	Screw terminal Connectable cross section: 4 mm ² to 16 mm ²
Power loss, approx.	50 W
Width	50 mm (1.97 in)
Height	380 mm (14.96 in)
Depth, with spacer (included in scope of supply)	270 mm (10.63 in)
Weight, approx.	3.1 kg (7 lb)

Selection and ordering data

Description	Order No.
Voltage Clamping Module in booksize format	6SL3100-1VE00-0AA0

Accessories

Description	Order No.
Warning signs in foreign languages This set of foreign language warning signs can be placed on top of the standard German or English signs. One sign in each of the following languages is provided in each set: Chinese, Danish, Dutch, Finnish, French, Greek, Italian, Japanese, Korean, Portuguese, Spanish and Swedish.	6SL3166-3AB00-0AA0

SINAMICS S120

Load-side power components

Motor reactors for blocksize format

Overview



Motor reactors for blocksize format, frame sizes FSA and FSB

Motor reactors reduce the voltage loading on the motor windings. At the same time, the capacitive charge/discharge currents that place an additional load on the power unit when long motor cables are used are reduced. The maximum permissible output frequency when a motor reactor is used is 150 Hz.

The motor reactors are designed for a pulse frequency of 4 kHz. Higher pulse frequencies are not permissible.

The motor reactor must be installed as close as possible to the Power Module.

Motor reactors are approved for use only in conjunction with "Vector" and "V/f control" modes.

Technical data

DC link voltage 510 V to 720 V DC or line voltage 380 V to 480 V 3 AC		Motor reactor (for a 4 kHz pulse frequency)					
		6SE6400-3TC00-4AD2					
Rated current	A	4.5	4.5	4.5	4.5	4.5	
Power loss	kW	0.005	0.005	0.005	0.005	0.005	
Connection to the Power Module		Cable 4 x AWG16 (1.5 mm ²) length approx. 0.3 m (0.98 ft)	Cable 4 x AWG16 (1.5 mm ²) length approx. 0.3 m (0.98 ft)	Cable 4 x AWG16 (1.5 mm ²) length approx. 0.3 m (0.98 ft)	Cable 4 x AWG16 (1.5 mm ²) length approx. 0.3 m (0.98 ft)	Cable 4 x AWG16 (1.5 mm ²) length approx. 0.3 m (0.98 ft)	
Motor connection		Screw-type terminals for conductor cross section 6 mm ²	Screw-type terminals for conductor cross section 6 mm ²	Screw-type terminals for conductor cross section 6 mm ²	Screw-type terminals for conductor cross section 6 mm ²	Screw-type terminals for conductor cross section 6 mm ²	
PE connection		M5 bolt	M5 bolt	M5 bolt	M5 bolt	M5 bolt	
Max. permissible cable length between motor reactor and motor	m (ft)	100 (328) shielded 150 (492) unshielded	100 (328) shielded 150 (492) unshielded	100 (328) shielded 150 (492) unshielded	100 (328) shielded 150 (492) unshielded	100 (328) shielded 150 (492) unshielded	
Width	mm (inch)	75.5 (2.97)	75.5 (2.97)	75.5 (2.97)	75.5 (2.97)	75.5 (2.97)	
Height	mm (inch)	201 (7.91)	201 (7.91)	201 (7.91)	201 (7.91)	201 (7.91)	
Depth	mm (inch)	110 (4.33)	110 (4.33)	110 (4.33)	110 (4.33)	110 (4.33)	
Degree of protection ¹⁾		IP20	IP20	IP20	IP20	IP20	
Weight, approx.	kg (lb)	2 (4)	2 (4)	2 (4)	2 (4)	2 (4)	
Suitable for Power Module, blocksize format	Type	6SL3210-1SE11-3UA0	6SL3210-1SE11-7UA0	6SL3210-1SE12-2UA0	6SL3210-1SE13-1UA0	6SL3210-1SE14-1UA0	
Rated current of the Power Module	A	1.3	1.7	2.2	3.1	4.1	
Size		FSA	FSA	FSA	FSA	FSA	

¹⁾ With correctly connected connection cable to the Power Module.

Technical data (continued)

DC link voltage 510 V to 720 V DC or line voltage 380 V to 480 V 3 AC		Motor reactor (for a 4 kHz pulse frequency)					
		6SL3202-0AE21-0CA0			6SL3202-0AJ23-2CA0		
Rated current	A	10	10	10	32	32	32
Power loss	kW	0.02	0.02	0.02	0.06	0.06	0.06
Connection to the Power Module		Cable 4 x AWG14 (1.5 mm ²) length approx. 0.4 m (1.31 ft)	Cable 4 x AWG14 (1.5 mm ²) length approx. 0.4 m (1.31 ft)	Cable 4 x AWG14 (1.5 mm ²) length approx. 0.4 m (1.31 ft)	Cable 4 x 6 mm ² length approx. 0.35 m (1.15 ft)	Cable 4 x 6 mm ² length approx. 0.35 m (1.15 ft)	Cable 4 x 6 mm ² length approx. 0.35 m (1.15 ft)
Motor connection		Screw-type terminals for conductor cross section 6 mm ²	Screw-type terminals for conductor cross section 6 mm ²	Screw-type terminals for conductor cross section 6 mm ²	Screw-type terminals for conductor cross section 6 mm ²	Screw-type terminals for conductor cross section 6 mm ²	Screw-type terminals for conductor cross section 6 mm ²
PE connection		M5 bolt	M5 bolt	M5 bolt	M5 bolt	M5 bolt	M5 bolt
Max. permissible cable length between motor reactor and motor	m (ft)	100 (328) shielded 150 (492) unshielded	100 (328) shielded 150 (492) unshielded	100 (328) shielded 150 (492) unshielded	100 (328) shielded 150 (492) unshielded	100 (328) shielded 150 (492) unshielded	100 (328) shielded 150 (492) unshielded
Width	mm (inch)	153 (6.02)	153 (6.02)	153 (6.02)	189 (7.44)	189 (7.44)	189 (7.44)
Height	mm (inch)	285 (11.22)	285 (11.22)	285 (11.22)	351 (13.82)	351 (13.82)	351 (13.82)
Depth	mm (inch)	70 (2.76)	70 (2.76)	70 (2.76)	80 (3.15)	80 (3.15)	80 (3.15)
Degree of protection ¹⁾		IP20	IP20	IP20	IP20	IP20	IP20
Weight, approx.	kg (lb)	4.5 (10)	4.5 (10)	4.5 (10)	9 (20)	9 (20)	9 (20)
Suitable for Power Module, blocksize format	Type	6SL3210-1SE16-0 . A0	6SL3210-1SE17-7 . A0	6SL3210-1SE21-0 . A0	6SL3210-1SE21-8 . A0	6SL3210-1SE22-5 . A0	6SL3210-1SE23-2 . A0
Rated current of the Power Module	A	5.9	7.7	10	18	25	32
Size		FSB	FSB	FSB	FSC	FSC	FSC

DC link voltage 510 V to 720 V DC or line voltage 380 V to 480 V 3 AC		Motor reactor (for a 4 kHz pulse frequency)				
		6SE6400-3TC05-4DD0	6SE6400-3TC03-8DD0	6SE6400-3TC05-4DD0	6SE6400-3TC08-0ED0	6SE6400-3TC07-5ED0
Rated current	A	68	45	68	104	90
Power loss	kW	0.2	0.2	0.2	0.17	0.27
Connection to the Power Module		Flat terminator for M6 cable lug	Flat terminator for M6 cable lug	Flat terminator for M6 cable lug	Flat terminator for M6 cable lug	Flat terminator for M6 cable lug
Motor connection		Flat terminator for M6 cable lug	Flat terminator for M6 cable lug	Flat terminator for M6 cable lug	Flat terminator for M6 cable lug	Flat terminator for M6 cable lug
PE connection		M6 screw	M6 screw	M6 screw	M6 screw	M6 screw
Max. permissible cable length between motor reactor and motor	m (ft)	200 (656) shielded 300 (984) unshielded	200 (656) shielded 300 (984) unshielded	200 (656) shielded 300 (984) unshielded	200 (656) shielded 300 (984) unshielded	200 (656) shielded 300 (984) unshielded
Width	mm (inch)	225 (8.86)	225 (8.86)	225 (8.86)	225 (8.86)	270 (10.63)
Height	mm (inch)	210 (8.27)	210 (8.27)	210 (8.27)	210 (8.27)	248 (9.76)
Depth	mm (inch)	140 (5.51)	140 (5.51)	140 (5.51)	140 (5.51)	189 (7.44)
Degree of protection		IP00	IP00	IP00	IP00	IP00
Weight, approx.	kg (lb)	11.5 (25)	19 (42)	11.5 (25)	12 (26)	27 (59)
Suitable for Power Module, blocksize format	Type	6SL3210-1SE23-8 . A0	6SL3210-1SE24-5 . A0	6SL3210-1SE26-0 . A0	6SL3210-1SE27-5 . A0	6SL3210-1SE31-0 . A0
Rated current of the Power Module	A	38	45	60	75	90
Size		FSD	FSD	FSD	FSE	FSE

¹⁾ With correctly connected connection cable to the Power Module.

SINAMICS S120

Load-side power components

Motor reactors for blocksize format

Technical data (continued)

DC link voltage 510 V to 720 V DC or line voltage 380 V to 480 V 3 AC		Motor reactor (for a 4 kHz pulse frequency)		
		6SE6400-3TC14-5FD0	6SE6400-3TC14-5FD0	6SE6400-3TC14-5FD0
Rated current	A	178	178	178
Power loss	kW	0.47	0.25	0.47
Connection to the Power Module		Flat terminator for M8 cable lug	Flat terminator for M8 cable lug	Flat terminator for M8 cable lug
Motor connection		Flat terminator for M8 cable lug	Flat terminator for M8 cable lug	Flat terminator for M8 cable lug
PE connection		M8 screw	M8 screw	M8 screw
Max. permissible cable length between motor reactor and motor	m (ft)	200 (656) shielded 300 (984) unshielded	200 (656) shielded 300 (984) unshielded	200 (656) shielded 300 (984) unshielded
Width	mm (inch)	357 (14.05)	270 (10.63)	357 (14.05)
Height	mm (inch)	321 (12.64)	248 (9.76)	321 (12.64)
Depth	mm (inch)	221 (8.7)	189 (7.44)	221 (8.7)
Degree of protection		IP00	IP00	IP00
Weight, approx.	kg (lb)	57 (126)	24 (53)	57 (126)
Suitable for Power Module, blocksize format	Type	6SL3210-1SE31-1 . A0	6SL3210-1SE31-5 . A0	6SL3210-1SE31-8 . A0
Rated current of the Power Module	A	110	145	178
Size		FSF	FSF	FSF

Selection and ordering data

Rated output current A	Rated power kW (HP)	Suitable for PM340 Power Module		Motor reactor
		Type	Size	Order No.
Line voltage 380 V to 480 V 3 AC				
1.3	0.37 (0.5)	6SL3210-1SE11-3UA0	FSA	6SE6400-3TC00-4AD2
1.7	0.55 (1)	6SL3210-1SE11-7UA0	FSA	6SE6400-3TC00-4AD2
2.2	0.75 (1)	6SL3210-1SE12-2UA0	FSA	6SE6400-3TC00-4AD2
3.1	1.1 (1.5)	6SL3210-1SE13-1UA0	FSA	6SE6400-3TC00-4AD2
4.1	1.5 (2)	6SL3210-1SE14-1UA0	FSA	6SE6400-3TC00-4AD2
5.9	2.2 (3)	6SL3210-1SE16-0...	FSB	6SL3202-0AE21-0CA0
7.7	3 (4)	6SL3210-1SE17-7...	FSB	6SL3202-0AE21-0CA0
10	4 (5)	6SL3210-1SE21-0...	FSB	6SL3202-0AE21-0CA0
18	7.5 (10)	6SL3210-1SE21-8...	FSC	6SL3202-0AJ23-2CA0
25	11 (15)	6SL3210-1SE22-5...	FSC	6SL3202-0AJ23-2CA0
32	15 (20)	6SL3210-1SE23-2...	FSC	6SL3202-0AJ23-2CA0
38	18.5 (25)	6SL3210-1SE23-8...	FCD	6SE6400-3TC05-4DD0
45	22 (30)	6SL3210-1SE24-5...	FCD	6SE6400-3TC03-8DD0
60	30 (40)	6SL3210-1SE26-0...	FCD	6SE6400-3TC05-4DD0
75	37 (50)	6SL3210-1SE27-5...	FSE	6SE6400-3TC08-0ED0
90	45 (60)	6SL3210-1SE31-0...	FSE	6SE6400-3TC07-5ED0
110	55 (70)	6SL3210-1SE31-1...	FSF	6SE6400-3TC14-5FD0
145	75 (100)	6SL3210-1SE31-5...	FSF	6SE6400-3TC15-4FD0
178	90 (120)	6SL3210-1SE31-8...	FSF	6SE6400-3TC14-5FD0

Overview



Motor reactors reduce the voltage loading on the motor windings. At the same time, the capacitive charge/discharge currents that place an additional load on the power unit when long motor cables are used are reduced. The maximum permissible output frequency when a motor reactor is used is 120 Hz.

The motor reactors are designed for a pulse frequency of 4 kHz. Higher pulse frequencies are not permissible.

The motor reactor must be installed as close as possible to the Motor Module.

Motor reactors are approved for use only in conjunction with "Vector" and "V/f control" modes.

Selection and ordering data

Rated output current of Motor Module	Suitable for Motor Module	Motor reactor
		Order No.
3 A and 2 × 3 A	6SL3120-1TE13-0AA0	6SE7021-0ES87-1FE0
	6SL3120-1TE13-0AB0	
	6SL3121-1TE13-0AA0	
	6SL3120-2TE13-0AA0	
	6SL3120-2TE13-0AB0	
	6SL3121-2TE13-0AA0	
5 A and 2 × 5 A	6SL3120-1TE15-0AA0	6SE7021-0ES87-1FE0
	6SL3120-1TE15-0AB0	
	6SL3121-1TE15-0AA0	
	6SL3120-2TE15-0AA0	
	6SL3120-2TE15-0AB0	
	6SL3121-2TE15-0AA0	
9 A and 2 × 9 A	6SL3120-1TE21-0AA1	6SL3000-2BE21-0AA0
	6SL3120-1TE21-0AB0	
	6SL3121-1TE21-0AA0	
	6SL3120-2TE21-0AA0	
	6SL3120-2TE21-0AB0	
	6SL3121-2TE21-0AA0	
18 A and 2 × 18 A	6SL3120-1TE21-8AA1	6SE7022-6ES87-1FE0
	6SL3120-1TE21-8AB0	
	6SL3121-1TE21-8AA0	
	6SL3120-2TE21-8AA0	
	6SL3120-2TE21-8AB0	
	6SL3121-2TE21-8AA0	
30 A	6SL3120-1TE23-0AA1	6SE7024-7ES87-1FE0
	6SL3120-1TE23-0AB0	
	6SL3121-1TE23-0AA0	
45 A	6SL3120-1TE24-5AA1	6SE7027-2ES87-1FE0
	6SL3120-1TE24-5AB0	
	6SL3121-1TE24-5AA0	
60 A	6SL3120-1TE26-0AA1	6SL3000-2BE26-0AA0
	6SL3120-1TE26-0AB0	
	6SL3121-1TE26-0AA0	
85 A	6SL3120-1TE28-5AA1	6SE7031-5ES87-1FE0
	6SL3120-1TE28-5AB0	
	6SL3121-1TE28-5AA0	
132 A	6SL3120-1TE31-3AA0	6SE7031-8ES87-1FE0
	6SL3120-1TE31-3AB0	
	6SL3121-1TE31-3AA0	
200 A	6SL3120-1TE32-0AA0	6SE7032-6ES87-1FE0
	6SL3120-1TE32-0AB0	
	6SL3121-1TE32-0AA0	

SINAMICS S120

Load-side power components

Motor reactors for booksize format

Technical data

DC link voltage 510 V to 720 V DC or line voltage 380 V to 480 V 3 AC		Motor reactor (for a 4 kHz pulse frequency)				
		6SE7021-0ES87-1FE0	6SL3000-2BE21-0AA0	6SE7022-6ES87-1FE0	6SE7024-7ES87-1FE0	
Rated current	A	9.2	9.2	9	23	42
Power loss	kW	0.08	0.08	0.07	0.11	0.19
Connection Motor Module/Motor		4 mm ² screw-type terminals	4 mm ² screw-type terminals	4 mm ² screw-type terminals	10 mm ² screw-type terminals	Flat terminator for M8 cable lug
PE connection		M6 bolt	M6 bolt	M6 bolt	M6 bolt	M6 grounding stud
Max. permissible cable length between motor reactor and motor	m (ft)	100 (328) shielded 150 (492) unshielded	100 (328) shielded 150 (492) unshielded	135 (443) shielded 200 (656) unshielded	160 (525) shielded 240 (787) unshielded	190 (623) shielded 280 (917) unshielded
Width	mm (inch)	178 (7)	178 (7)	178 (7)	219 (8.62)	197 (7.76)
Height	mm (inch)	153 (6.02)	153 (6.02)	159 (6.26)	180 (7.09)	220 (8.66)
Depth	mm (inch)	97 (3.82)	97 (3.82)	111 (4.37)	132 (5.2)	121 (4.76)
Degree of protection		IP00	IP00	IP00	IP00	IP00
Weight, approx.	kg (lb)	6 (13)	6 (13)	5 (11)	9.5 (21)	20 (44)
Suitable for Motor Module in booksize format	Type	6SL3120-1TE13-0AA0 6SL3120-1TE13-0AB0 6SL3121-1TE13-0AA0 6SL3120-2TE13-0AA0 6SL3120-2TE13-0AB0 6SL3121-2TE13-0AA0	6SL3120-1TE15-0AA0 6SL3120-1TE15-0AB0 6SL3121-1TE15-0AA0 6SL3120-2TE15-0AA0 6SL3120-2TE15-0AB0 6SL3121-2TE15-0AA0	6SL3120-1TE21-0AA1 6SL3120-1TE21-0AB0 6SL3121-1TE21-0AA0 6SL3120-2TE21-0AA0 6SL3120-2TE21-0AB0 6SL3121-2TE21-0AA0	6SL3120-1TE21-8AA1 6SL3120-1TE21-8AB0 6SL3121-1TE21-8AA0 6SL3120-2TE21-8AA0 6SL3120-2TE21-8AB0 6SL3121-2TE21-8AA0	6SL3120-1TE23-0AA1 6SL3120-1TE23-0AB0 6SL3121-1TE23-0AA0
Rated current of the Motor Module	A	3	5	9	18	30

DC link voltage 510 V to 720 V DC or line voltage 380 V to 480 V 3 AC		Motor reactor (for a 4 kHz pulse frequency)				
		6SE7027-2ES87-1FE0	6SL3000-2BE26-0AA0	6SE7031-5ES87-1FE0	6SE7031-8ES87-1FE0	6SE7032-6ES87-1FE0
Rated current	A	65	60	131	167	234
Power loss	kW	0.2	0.1	0.22	0.29	0.29
Connection Motor Module/Motor		Flat terminator for M8 cable lug	Flat terminator for M8 cable lug	Flat terminator for M8 cable lug	Flat terminator for M8 cable lug	Flat terminator for M8 cable lug
PE connection		M6 bolt	M6 bolt	M6 grounding stud	M6 grounding stud	M6 grounding stud
Max. permissible cable length between motor reactor and motor	m (ft)	200 (656) shielded 300 (984) unshielded	200 (656) shielded 300 (984) unshielded	200 (656) shielded 300 (984) unshielded	200 (656) shielded 300 (984) unshielded	200 (656) shielded 300 (984) unshielded
Width	mm (inch)	267 (10.51)	267 (10.51)	219 (8.62)	281 (11.06)	281 (11.06)
Height	mm (inch)	221 (8.7)	220 (8.66)	220 (8.66)	250 (9.84)	250 (9.84)
Depth	mm (inch)	131 (5.16)	126 (4.96)	145 (5.7)	171 (6.73)	184 (7.24)
Degree of protection		IP00	IP00	IP00	IP00	IP00
Weight, approx.	kg (lb)	11 (24)	10.5 (23)	25 (55)	30 (66)	30 (66)
Suitable for Motor Module in booksize format	Type	6SL3120-1TE24-5AA1 6SL3120-1TE24-5AB0 6SL3121-1TE24-5AA0	6SL3120-1TE26-0AA1 6SL3120-1TE26-0AB0 6SL3121-1TE26-0AA0	6SL3120-1TE28-5AA1 6SL3120-1TE28-5AB0 6SL3121-1TE28-5AA0	6SL3120-1TE31-3AA0 6SL3120-1TE31-3AB0 6SL3121-1TE31-3AA0	6SL3120-1TE32-0AA0 6SL3120-1TE32-0AB0 6SL3121-1TE32-0AA0
Rated current of the Motor Module	A	45	60	85	132	200

Overview



Motor reactors reduce the voltage loading on the motor windings. At the same time, the capacitive charge/discharge currents that place an additional load on the power unit when long motor cables are used are reduced. The maximum permissible output frequency when a motor reactor is used is 150 Hz.

The motor reactor must be installed as close as possible to the Motor Module or Power Module.

Motor reactors are approved for use only in conjunction with "Vector" and "V/f control" modes.

Technical data

DC link voltage 510 V to 720 V DC or line voltage 380 V to 480 V 3 AC		Motor reactor (for pulse frequencies of 2 kHz to 4 kHz)				
		6SL3000- 2BE32-1AA0	6SL3000- 2BE32-6AA0	6SL3000- 2BE33-2AA0	6SL3000- 2BE33-8AA0	6SL3000- 2BE35-0AA0
Rated current	A	210	260	310	380	490
Power loss	kW	0.486	0.5	0.47	0.5	0.5
Line/load connection		M10	M10	M10	M10	M12
PE connection		M8	M8	M8	M8	M8
Max. permissible cable length between motor reactor and motor	m (ft)	300 (984) shielded 450 (1477) unshielded	300 (984) shielded 450 (1477) unshielded	300 (984) shielded 450 (1477) unshielded	300 (984) shielded 450 (1477) unshielded	300 (984) shielded 450 (1477) unshielded
Width	mm (inch)	300 (11.81)	300 (11.81)	300 (11.81)	300 (11.81)	300 (11.81)
Height	mm (inch)	285 (11.22)	315 (12.4)	285 (11.22)	285 (11.22)	365 (14.37)
Depth	mm (inch)	257 (10.12)	277 (10.9)	257 (10.12)	277 (10.9)	277 (10.9)
Degree of protection		IP00	IP00	IP00	IP00	IP00
Weight, approx.	kg (lb)	66 (146)	66 (146)	66 (146)	73 (161)	100 (221)
Suitable for Single Motor Module in chassis format	Type	6SL3320-1TE32-1AA0	6SL3320-1TE32-6AA0	6SL3320-1TE33-1AA0	6SL3320-1TE33-8AA0	6SL3320-1TE35-0AA0
Suitable for Power Module in chassis format	Type	6SL3310-1TE32-1AA0	6SL3310-1TE32-6AA0	6SL3310-1TE33-1AA0	6SL3310-1TE33-8AA0	6SL3310-1TE35-0AA0
Rated current of Motor Module or Power Module	A	210	260	310	380	490
Rated output of the Motor Module or Power Module	kW (HP)	110 (150)	132 (200)	160 (250)	200 (300)	250 (400)

SINAMICS S120

Load-side power components

Motor reactors for chassis format

Technical data

DC link voltage 510 V to 720 V DC or line voltage 380 V to 480 V 3 AC		Motor reactor (for pulse frequencies of 1.25 kHz to 2.5 kHz)					
		6SL3000- 2AE36-1AA0	6SL3000- 2AE38-4AA0	6SL3000- 2AE38-4AA0	6SL3000- 2AE41-0AA0	6SL3000-2AE41-4AA0	
Rated current	A	605	840	840	985	1405	1405
Power loss	kW	0.9	0.83	0.943	1.062	0.962	1.054
Line/load connection		M12	M12	M12	M12	2 x M12	2 x M12
PE connection		M8	M10	M10	M10	M10	M10
Max. permissible cable length between motor reactor and motor	m (ft)	300 (984) shielded 450 (1477) unshielded	300 (984) shielded 450 (1477) unshielded	300 (984) shielded 450 (1477) unshielded	300 (984) shielded 450 (1477) unshielded	300 (984) shielded 450 (1477) unshielded	300 (984) shielded 450 (1477) unshielded
Width	mm (inch)	410 (16.14)	410 (16.14)	410 (16.14)	410 (16.14)	460 (18.11)	460 (18.11)
Height	mm (inch)	392 (15.43)	392 (15.43)	392 (15.43)	392 (15.43)	392 (15.43)	392 (15.43)
Depth	mm (inch)	292 (11.5)	292 (11.5)	292 (11.5)	302 (11.89)	326 (12.83)	326 (12.83)
Degree of protection		IP00	IP00	IP00	IP00	IP00	IP00
Weight, approx.	kg (lb)	130 (287)	140 (309)	140 (309)	146 (322)	179 (395)	179 (395)
Suitable for Single Motor Module in chassis format	Type	6SL3320- 1TE36-1AA0	6SL3320- 1TE37-5AA0	6SL3320- 1TE38-4AA0	6SL3320- 1TE41-0AA0	6SL3320- 1TE41-2AA0	6SL3320- 1TE41-4AA0
Rated current of the Motor Module	A	605	745	840	985	1260	1405
Rated output of the Motor Module	kW (HP)	315 (500)	400 (600)	450 (700)	560 (800)	710 (1000)	800 (1150)

DC link voltage 890 V to 1035 V DC or line voltage 660 V to 690 V 3 AC		Motor reactor (for pulse frequencies of 1.25 kHz to 2.5 kHz)					
		6SL3000-2AH31-0AA0		6SL3000-2AH31-5AA0		6SL3000- 2AH31-8AA0	6SL3000- 2AH32-4AA0
Rated current	A	100	100	150	150	175	240
Power loss	kW	0.257	0.3	0.318	0.335	0.4	0.425
Line/load connection		M10	M10	M10	M10	M10	M10
PE connection		M6	M6	M6	M6	M6	M6
Max. permissible cable length between motor reactor and motor	m (ft)	200 (656) shielded 300 (984) unshielded	200 (656) shielded 300 (984) unshielded	200 (656) shielded 300 (984) unshielded	200 (656) shielded 300 (984) unshielded	200 (656) shielded 300 (984) unshielded	200 (656) shielded 300 (984) unshielded
Width	mm (inch)	270 (10.63)	270 (10.63)	270 (10.63)	270 (10.63)	300 (11.81)	300 (11.81)
Height	mm (inch)	248 (9.76)	248 (9.76)	248 (9.76)	248 (9.76)	285 (11.22)	285 (11.22)
Depth	mm (inch)	200 (7.87)	200 (7.87)	200 (7.87)	200 (7.87)	212 (8.35)	212 (8.35)
Degree of protection		IP00	IP00	IP00	IP00	IP00	IP00
Weight, approx.	kg (lb)	25 (55)	25 (55)	25.8 (57)	25.8 (57)	34 (75)	34 (75)
Suitable for Single Motor Module in chassis format	Type	6SL3320- 1TH28-5AA0	6SL3320- 1TH31-0AA0	6SL3320- 1TH31-2AA0	6SL3320- 1TH31-5AA0	6SL3320- 1TH31-8AA0	6SL3320- 1TH32-2AA0
Rated current of the Motor Module	A	85	100	120	150	175	215
Rated output of the Motor Module	kW	75	90	110	132	160	200

Technical data

DC link voltage 890 V to 1035 V DC or line voltage 660 V to 690 V 3 AC		Motor reactor (for pulse frequencies of 1.25 kHz to 2.5 kHz)					
		6SL3000- 2AH32-6AA0	6SL3000- 2AH33-6AA0	6SL3000- 2AH34-5AA0	6SL3000- 2AH34-7AA0	6SL3000- 2AH35-8AA0	6SL3000- 2AH38-1AA0
Rated current	A	260	360	450	465	575	810
Power loss	kW	0.44	0.45	0.545	0.72	0.8	0.96
Line/load connection		M10	M10	M12	M12	M12	M12
PE connection		M6	M6	M8	M8	M8	M8
Max. permissible cable length between motor reactor and motor	m (ft)	200 (656) shielded 300 (984) unshielded	200 (656) shielded 300 (984) unshielded	200 (656) shielded 300 (984) unshielded	200 (656) shielded 300 (984) unshielded	200 (656) shielded 300 (984) unshielded	200 (656) shielded 300 (984) unshielded
Width	mm (inch)	300 (11.81)	300 (11.81)	350 (13.78)	410 (16.14)	410 (16.14)	410 (16.14)
Height	mm (inch)	285 (11.22)	285 (11.22)	330 (12.99)	392 (15.43)	392 (15.43)	392 (15.43)
Depth	mm (inch)	212 (8.35)	212 (8.35)	215 (8.46)	292 (11.5)	292 (11.5)	279 (10.98)
Degree of protection		IP00	IP00	IP00	IP00	IP00	IP00
Weight, approx.	kg (lb)	40 (88)	46 (101)	68 (150)	80 (176)	80 (176)	146 (322)
Suitable for Single Motor Module in chassis format	Type	6SL3320- 1TH32-6AA0	6SL3320- 1TH33-3AA0	6SL3320- 1TH34-1AA0	6SL3320- 1TH34-7AA0	6SL3320- 1TH35-8AA0	6SL3320- 1TH37-4AA0
Rated current of the Motor Module	A	260	330	410	465	575	735
Rated output of the Motor Module	kW	250	315	400	450	560	710

DC link voltage 890 V to 1035 V DC or line voltage 660 V to 690 V 3 AC		Motor reactor (for pulse frequencies of 1.25 kHz to 2.5 kHz)			
		6SL3000-2AH38-1AA0	6SL3000-2AH41-0AA0	6SL3000-2AH41-1AA0	6SL3000-2AH41-3AA0
Rated current	A	810	910	1025	1270
Power loss	kW	1.0	0.97	1.05	0.95
Line/load connection		M12	M12	M12	M12
PE connection		M8	M8	M8	M8
Max. permissible cable length between motor reactor and motor	m (ft)	200 (656) shielded 300 (984) unshielded	200 (656) shielded 300 (984) unshielded	200 (656) shielded 300 (984) unshielded	200 (656) shielded 300 (984) unshielded
Width	mm (inch)	410 (16.14)	410 (16.14)	410 (16.14)	460 (18.11)
Height	mm (inch)	392 (15.43)	392 (15.43)	392 (15.43)	392 (15.43)
Depth	mm (inch)	279 (10.98)	279 (10.98)	317 (12.48)	296 (11.65)
Degree of protection		IP00	IP00	IP00	IP00
Weight, approx.	kg (lb)	146 (322)	150 (331)	163 (360)	153 (337)
Suitable for Single Motor Module in chassis format	Type	6SL3320-1TH38-1AA0	6SL3320-1TH38-8AA0	6SL3320-1TH41-0AA0	6SL3320-1TH41-3AA0
Rated current of the Motor Module	A	810	910	1025	1270
Rated output of the Motor Module	kW	800	900	1000	1200

SINAMICS S120

Load-side power components

Motor reactors for chassis format

Selection and ordering data

Rated current of the Motor Module or Power Module	Rated output of the Motor Module or Power Module	Suitable for Motor Module/Power Module	Motor reactor
A	kW (HP)	Type	Order No.
DC link voltage 510 V to 720 V DC (line voltage 380 V to 480 V 3 AC)			
210	110 (150)	6SL33 . 0-1TE32-1AA0	6SL3000-2BE32-1AA0
260	132 (200)	6SL33 . 0-1TE32-6AA0	6SL3000-2BE32-6AA0
310	160 (250)	6SL33 . 0-1TE33-1AA0	6SL3000-2BE33-2AA0
380	200 (300)	6SL33 . 0-1TE33-8AA0	6SL3000-2BE33-8AA0
490	250 (400)	6SL33 . 0-1TE35-0AA0	6SL3000-2BE35-0AA0
605	315 (500)	6SL3320-1TE36-1AA0	6SL3000-2AE36-1AA0
745	400 (600)	6SL3320-1TE37-5AA0	6SL3000-2AE38-4AA0
840	450 (700)	6SL3320-1TE38-4AA0	6SL3000-2AE38-4AA0
985	560 (800)	6SL3320-1TE41-0AA0	6SL3000-2AE41-0AA0
1260	710 (1000)	6SL3320-1TE41-2AA0	6SL3000-2AE41-4AA0
1405	800 (1150)	6SL3320-1TE41-4AA0	6SL3000-2AE41-4AA0
DC link voltage 890 V to 1035 V DC (line voltage 660 V to 690 V 3 AC)			
85	75	6SL3320-1TH28-5AA0	6SL3000-2AH31-0AA0
100	90	6SL3320-1TH31-0AA0	6SL3000-2AH31-0AA0
120	110	6SL3320-1TH31-2AA0	6SL3000-2AH31-5AA0
150	132	6SL3320-1TH31-5AA0	6SL3000-2AH31-5AA0
175	160	6SL3320-1TH31-8AA0	6SL3000-2AH31-8AA0
215	200	6SL3320-1TH32-2AA0	6SL3000-2AH32-4AA0
260	250	6SL3320-1TH32-6AA0	6SL3000-2AH32-6AA0
330	315	6SL3320-1TH33-3AA0	6SL3000-2AH33-6AA0
410	400	6SL3320-1TH34-1AA0	6SL3000-2AH34-5AA0
465	450	6SL3320-1TH34-7AA0	6SL3000-2AH34-7AA0
575	560	6SL3320-1TH35-8AA0	6SL3000-2AH35-8AA0
735	710	6SL3320-1TH37-4AA0	6SL3000-2AH38-1AA0
810	800	6SL3320-1TH38-1AA0	6SL3000-2AH38-1AA0
910	900	6SL3320-1TH38-8AA0	6SL3000-2AH41-0AA0
1025	1000	6SL3320-1TH41-0AA0	6SL3000-2AH41-1AA0
1270	1200	6SL3320-1TH41-3AA0	6SL3000-2AH41-3AA0

Overview



If a sinusoidal filter is connected at the Motor Module output, the voltage between the motor terminals is virtually sinusoidal. This reduces the voltage load on the motor windings and prevents motor noise induced by the pulse frequency.

The pulse frequency of the Motor Modules must be set to 4 kHz for the sinusoidal filters.

With chassis format units, this reduces the maximum possible output current and the maximum achievable output voltage (see characteristics for Single Motor Modules in chassis format and System Description). The voltage drops across the sinusoidal filter, a factor which must also be taken into account in the drive design (see System Description)

The sinusoidal filter must be installed as close as possible to the Motor Module.

Technical data

DC link voltage 510 V to 720 V DC		Sinusoidal filter for chassis format 6SL3000-2CE32-3AA0				
		6SL3000-2CE32-8AA0	6SL3000-2CE33-3AA0	6SL3000-2CE33-8AA0	6SL3000-2CE34-1AA0	
Rated current	A	225	225	276	333	408
Power loss 50 Hz/60 Hz	kW	0.35/0.6	0.35/0.6	0.4/0.69	0.245/0.53	0.38/0.7
Line/load connection		M10 connecting lugs	M10 connecting lugs	M10 connecting lugs	M10 connecting lugs	M10 connecting lugs
PE connection		M10 connecting lugs	M10 connecting lugs	M10 connecting lugs	M10 connecting lugs	M10 connecting lugs
Max. permissible cable length between sinusoidal filter and motor	m (ft)	300 (984) shielded 450 (1477) unshielded	300 (984) shielded 450 (1477) unshielded	300 (984) shielded 450 (1477) unshielded	300 (984) shielded 450 (1477) unshielded	300 (984) shielded 450 (1477) unshielded
Degree of protection		IP00	IP00	IP00	IP00	IP00
Width	mm (inch)	620 (24.4)	620 (24.4)	620 (24.4)	620 (24.4)	620 (24.4)
Height	mm (inch)	300 (11.81)	300 (11.81)	300 (11.81)	370 (14.57)	370 (14.57)
Depth	mm (inch)	320 (12.6)	320 (12.6)	320 (12.6)	360 (14.17)	360 (14.17)
Weight, approx.	kg (lb)	124 (273)	124 (273)	127 (280)	136 (300)	198 (437)
Suitable for Single Motor Module in chassis format	Type	6SL3320-1TE32-1AA0	6SL3320-1TE32-6AA0	6SL3320-1TE33-1AA0	6SL3320-1TE33-8AA0	6SL3320-1TE35-0AA0
Suitable for Power Module in chassis format	Type	6SL3310-1TE32-1AA0	6SL3310-1TE32-6AA0	6SL3310-1TE33-1AA0	6SL3310-1TE33-8AA0	6SL3310-1TE35-0AA0
Rated current of the Motor Module or Power Module at pulse frequency of 4 kHz	A	170	215	270	330	380
Rated output of the Motor Module or Power Module at pulse frequency of 4 kHz	kW (HP)	90 (120)	110 (150)	132 (200)	160 (250)	200 (400)

SINAMICS S120

Load-side power components

Sinusoidal filter for chassis format

Selection and ordering data

Rated output current of the Motor Module or Power Module	Rated output of the Motor Module or Power Module	Suitable for Motor Module/Power Module	Sinusoidal filter
A	kW (HP)	Type	Order No.
DC link voltage 510 V to 720 V DC (line voltage 380 V to 480 V 3 AC)			
210	110 (150)	6SL33 . 0-1TE32-1AA0	6SL3000-2CE32-3AA0
260	132 (200)	6SL33 . 0-1TE32-6AA0	6SL3000-2CE32-3AA0
310	160 (250)	6SL33 . 0-1TE33-1AA0	6SL3000-2CE32-8AA0
380	200 (300)	6SL33 . 0-1TE33-8AA0	6SL3000-2CE33-3AA0
490	250 (400)	6SL33 . 0-1TE35-0AA0	6SL3000-2CE34-1AA0

Overview



BOP20 Basic Operator Panel

The BOP20 Basic Operator Panel can be inserted on any CU310 or CU320 Control Unit and may be used to acknowledge faults, set parameters and read diagnostic information (e.g. warnings and fault messages).

Design

The BOP20 basic operator panel has a backlit two-line display area and 6 keys.

The integrated plug connector on the back of the BOP20 Basic Operator Panel is used for the power supply of the BOP20 Basic Operator Panel and communication with the CU310 or CU320 Control Unit.

Integration



CU310 DP Control Unit with mounted BOP20 Basic Operator Panel



CU320 Control Unit with mounted BOP20 Basic Operator Panel

Selection and ordering data

Description	Order No.
BOP20 Basic Operator Panel	6SL3055-0AA00-4BA0

SINAMICS S120

Supplementary system components

CBC10 Communication Board

Overview



The CBC10 Communication Board is used to interface the CU320 Control Unit and therefore the drives to the CAN (Controller Area Network) protocol. The board's driver software fulfills the standards of the following CANopen specification of the CiA organization (CAN in Automation):

- Communication profiles in accordance with DS 301
- Drive profile in accordance with DSP 402 (in this case Profile Velocity Mode)
- EDS (Electronic Data Sheet) in accordance with DSP 306
- Operational status signaling in accordance with DSP 305

Design

The CBC10 Communication Board plugs into the option slot on the CU320 Control Unit. The CAN interface on the CBC10 has 2 SUB-D connections in each case of input and output.

Technical data

CBC10 Communication Board	
Max. current requirement (at 24 V DC) via CU320 Control Unit	0.05 A
Power loss	< 10 W
Weight, approx.	0.1 kg (0.2 lb)

Selection and ordering data

Description	Order No.
CBC10 Communication Board	6SL3055-0AA00-2CA0

Accessories

Description	Order No.
SUB-D connector , 9-pin, female (3x)	6FC9341-2AE
SUB-D connector , 9-pin, male (3x)	6FC9341-2AF

Overview

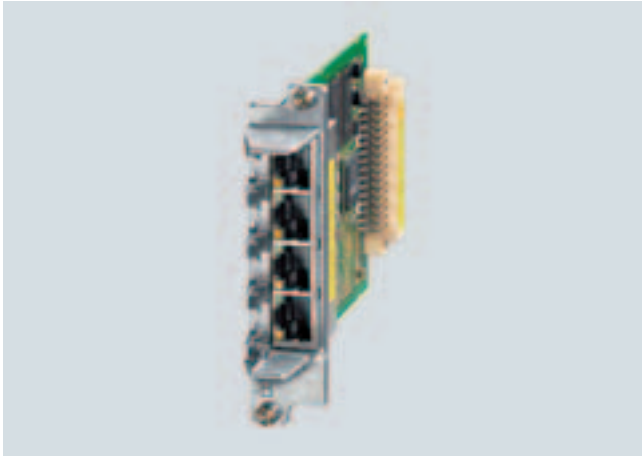

The CBE20 Communication Board can be used to connect the SINAMICS S120 drive system to a PROFINET IO network via a CU320 Control Unit. The SINAMICS S120 then assumes the function of a PROFINET IO device and can perform the following:

- PROFINET IO device functions
- 100 Mbit/s full duplex
- Supports real-time classes of PROFINET IO:
 - RT (RealTime)
 - IRT (Isochronous RealTime)
- Connects to controls as PROFINET IO devices using PROFIdrive compliant with specification V4
- Standard TCP/IP communication for engineering processes using the STARTER drive/commissioning software
- Integrated 4-port switch with four RJ45 sockets based on the PROFINET ASIC ERTEC400. The optimum topology (line, star, tree) can therefore be configured without additional external switches.

Integration

The CBE20 Communication Board plugs into the option slot on the CU320 Control Unit.

Technical data

CBE20 Communication Board

Max. current requirement (at 24 V DC)	0.16 A
Permissible ambient temperature	
• Storage and transport	- 40 °C to + 70 °C (- 40 °F to + 158 °F)
• Operation	0 °C to + 55 °C (32 °F to + 131 °F)
Dimensions	130 mm × 78 mm (5.11 in × 3.07 in)
Weight, approx.	76 g (0.17 lb)

Selection and ordering data

Description	Order No.
CBE20 Communication Board	6SL3055-0AA00-2EB0

Accessories

The PROFINET cables and connectors listed below are recommended:

Description	Order No.
Industrial Ethernet FC	
• RJ45 plug 145 (1 x)	6GK1901-1BB30-0AA0
• RJ45 plug 145 (10 x)	6GK1901-1BB30-0AB0
• Stripping tool	6GK1901-1GA00
• Standard cable GP 2x2	6XV1840-2AH10
• Flexible cable GP 2x2	6XV1870-2B
• Trailing cable GP 2x2	6XV1870-2D
• Trailing cable 2x2	6XV1840-3AH10
• Marine cable 2x2	6XV1840-4AH10

For further details about connectors and cables, please refer to Catalog IK PI.

SINAMICS S120

Supplementary system components

CBE30 Communication Board

Overview



The CBE30 Communication Board for SIMOTION D425, D435 and D445 allows the SIMOTION to be connected to a PROFINET IO network. The SIMOTION D then assumes the function of a PROFINET IO Controller and can perform the following functions:

- PROFINET IO Controller
- 100 Mbit/s full duplex
- Supports real-time classes of PROFINET IO:
 - RT (RealTime)
 - IRT (Isochronous RealTime)
- Connects distributed IOs as PROFINET IO devices
- Connects drives as PROFINET IO devices using PROFIdrive compliant with specification V4
- Supports standard Ethernet communication (TCP/IP), e.g. for interfacing SIMOTION SCOUT, HMI or standard TCP, UDP communication, to devices of any other type
- Integrated 4-port switch with four RJ45 sockets based on the PROFINET ASIC ERTEC400. The optimum topology (line, star, tree) can therefore be configured without additional external switches.

Integration

The CBE30 Communication Board plugs into the option slot on the SIMOTION D Control Unit.

Technical data

CBE30 Communication Board	
Max. current requirement (at 24 V DC)	0.25 A
Permissible ambient temperature	
• Storage and transport	- 40 °C to + 70 °C (- 40 °F to + 158 °F)
• Operation	0 °C to + 55 °C (32 °F to + 131 °F)
Dimensions	113 mm × 77 mm (4.45 in × 3.03 in)
Weight, approx.	100 g (0.22 lb)

Selection and ordering data

Description	Order No.
CBE30 Communication Board	6FC5312-0FA00-0AA0

Accessories

The PROFINET cables and connectors listed below are recommended:

Description	Order No.
Industrial Ethernet FC	
• RJ45 plug 145 (1 x)	6GK1901-1BB30-0AA0
• RJ45 plug 145 (10 x)	6GK1901-1BB30-0AB0
• Stripping tool	6GK1901-1GA00
• Standard cable GP 2x2	6XV1840-2AH10
• Flexible cable GP 2x2	6XV1870-2B
• Trailing cable GP 2x2	6XV1870-2D
• Trailing cable 2x2	6XV1840-3AH10
• Marine cable 2x2	6XV1840-4AH10

For further details about connectors and cables, please refer to Catalog IK PI.

Overview



The CUA31 Control Unit Adapter converts the PM-IF interface to a DRIVE-CLiQ interface. This adapter allows Power Modules in blocksize format to operate on a CU320 or SIMOTION D Control Unit.

Design

The CUA31 Control Unit Adapter features the following interfaces:

- 1 temperature sensor input (KTY84-130 or PTC)
- 3 DRIVE-CLiQ sockets
- 1 connection for the electronics power supply via the 24 V DC power supply connector
- 1 safe standstill input (enable pulses)

The status of the CUA31 Control Unit Adapter is indicated via multi-color LEDs.

Technical data

CUA31 Control Unit Adapter

Max. current requirement (at 24 V DC) without DRIVE-CLiQ supply	0.15 A
Max. connectable cross section	2.5 mm ²
Width	73 mm (2.87 in)
Height	165.8 mm (6.53 in)
Depth	37.3 mm (1.47 in)
Weight, approx.	0.31 kg (0.68 lb)

Selection and ordering data

Description	Order No.
CUA31 Control Unit Adapter (without DRIVE-CLiQ cable)	6SL3040-0PA00-0AA0

SINAMICS S120

Supplementary system components

CUA31 Control Unit Adapter

Integration

The CUA31 Control Unit Adapter is snapped onto the Power Module in blocksize format and communicates with the CU320 or SIMOTION D Control Unit by means of a DRIVE-CLiQ link.

The CUA31 Control Unit Adapter's power is supplied by the Power Module via the PM-IF interface. If the CUA31 Control Unit Adapter needs to communicate when the Power Module is switched off, it must be supplied with 24 V DC from an external source.

Other DRIVE-CLiQ devices such as Sensor Modules or Terminal Modules can be connected to the CUA31 Control Unit Adapter.

2

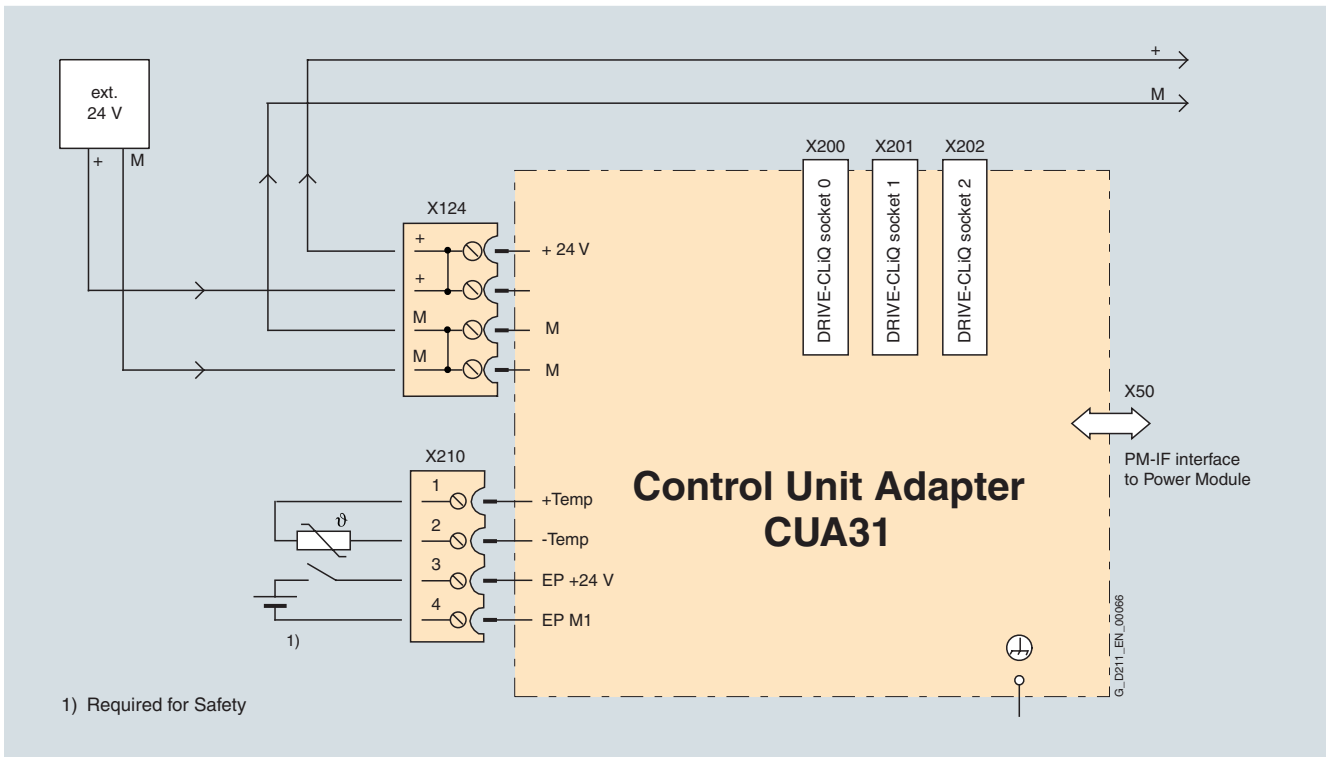

Overview



The DRIVE-CLiQ DMC20 Hub Module is used to implement star-shaped distribution of a DRIVE-CLiQ line. Two DRIVE-CLiQ DMC20 Hub Modules can be connected in series (cascaded).

Design

The following are located on the DRIVE-CLiQ DMC20 Hub Module:

- 6 DRIVE-CLiQ sockets for connecting 5 DRIVE-CLiQ devices
- 1 connection for the electronics power supply via the 24 V DC power supply connector

The status of the DRIVE-CLiQ DMC20 Hub Module is indicated via a multi-color LED.

Technical data

DMC20 DRIVE-CLiQ Hub Module

Max. current requirement (at 24 V DC) without DRIVE-CLiQ supply	0.15 A
Max. connectable cross section	2.5 mm ²
Width	50 mm (1.97 in)
Height	150 mm (5.91 in)
Depth	111 mm (4.37 in)
Weight, approx.	0.8 kg (2 lb)

Selection and ordering data

Description	Order No.
DRIVE-CLiQ DMC20 Hub Module (without DRIVE-CLiQ cable)	6SL3055-0AA00-6AA0

Integration

Signals from more than one encoder can be collected by the DRIVE-CLiQ DMC20 Hub Module and forwarded to the Control Unit on a single DRIVE-CLiQ cable.

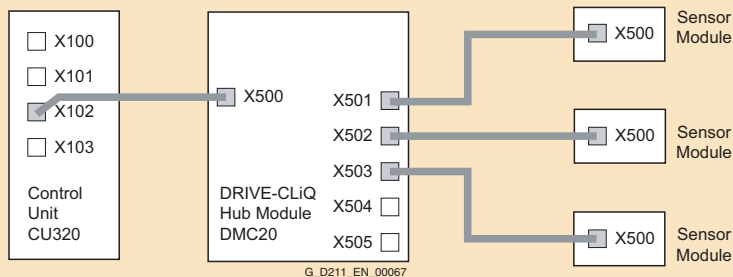

The DRIVE-CLiQ DMC20 Hub Module allows individual DRIVE-CLiQ devices to be removed without interrupting the data exchange with the remaining devices in the DRIVE-CLiQ line.

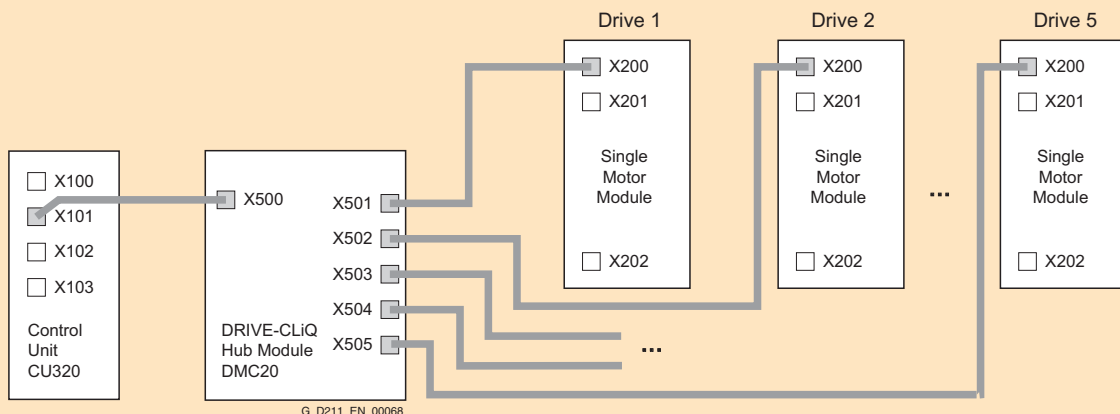

SINAMICS S120

Supplementary system components

TB30 Terminal Board

Overview



The TB30 Terminal Board supports the addition of digital inputs/digital outputs and analog inputs/analog outputs to the CU320 and SIMOTION D Control Units.

Design

The following are located on the TB30 Terminal Board:

- Power supply for digital inputs/digital outputs
- 4 digital inputs
- 4 digital outputs
- 2 analog inputs
- 2 analog outputs

The TB30 Terminal Board plugs into the option slot on a Control Unit.

A shield connection for the signal cable shield is located on the Control Unit.

Technical specifications

TB30 Terminal Board

Max. current requirement (at 24 V DC) via CU320 Control Unit without taking account of digital outputs	0.05 A
Max. connectable cross section	2.5 mm ²
Max. fuse protection	20 A
Digital inputs	
• Voltage	– 3 V to + 30 V
• Low level (an open digital input is interpreted as "low")	– 3 V to + 5 V
• High level	15 V to 30 V
• Current consumption (at 24 V DC)	Type 10 mA
• Signal propagation delays for digital inputs ¹⁾	L → H: approx. 50 μs H → L: approx. 100 μs
• Max. connectable cross section	0.5 mm ²
Digital outputs (continued-short-circuit-proof)	
• Voltage	24 V DC
• Max. load current per digital output	500 mA
• Max. connectable cross section	0.5 mm ²
Analog inputs (difference)	
• Voltage range (an open analog input is interpreted as 0 V)	– 10 V to + 10 V
• Internal resistance R_i	65 kOhm
• Resolution	13 bit, + sign
• Max. connectable cross section	0.5 mm ²
Analog outputs (continued-short-circuit-proof)	
• Voltage range	– 10 V to + 10 V
• Max. load current	– 3 mA to + 3 mA
• Resolution	11 bit, + sign
• Max. connectable cross section	0.5 mm ²
Power loss	< 3 W
Weight, approx.	0.1 kg (0.2 lb)
Approvals	cULus (File No.: E164110)

Selection and ordering data

Description	Order No.
TB30 Terminal Board	6SL3055-0AA00-2TA0

¹⁾ The specified signal propagation delays refer to the hardware. The actual reaction time depends on the time slot in which the digital input is processed.

Integration

2

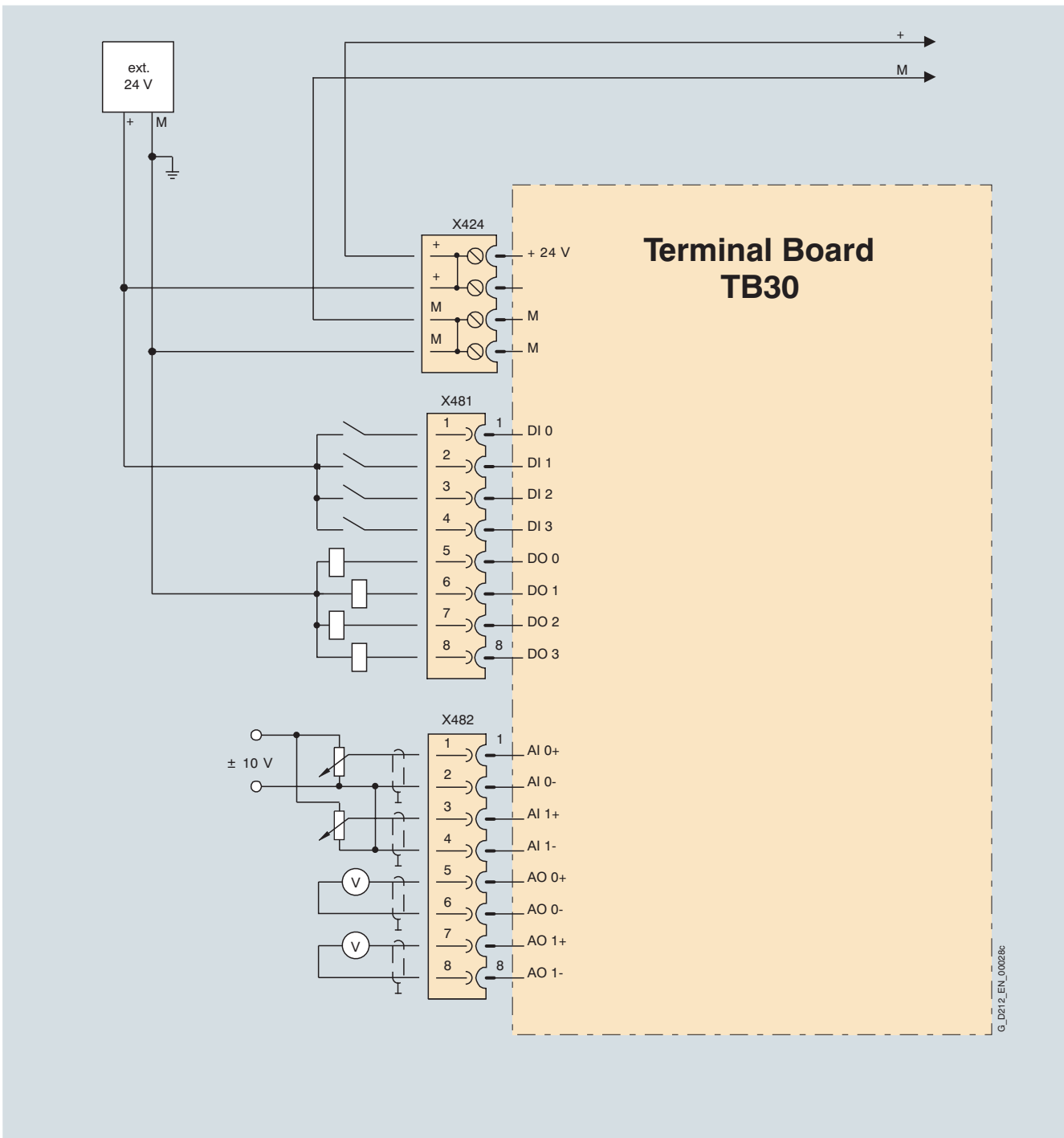

G_D212_EN_00028c

Connection example of TB30 Terminal Board

SINAMICS S120

Supplementary system components

TM15 Terminal Module

Overview



The number of available digital inputs and outputs within a drive system can be expanded with the TM15 Terminal Module.

Design

The following are located on the TM15 Terminal Module:

- 24 bidirectional digital inputs/outputs (isolation in 3 groups with 8 channels each)
- 24 green status LEDs for indicating the logical signal status of the relevant terminal
- 2 x DRIVE-CLiQ sockets
- 1 connection for the electronics power supply via the 24 V DC power supply connector
- 1 PE (protective earth) connection

The TM15 Terminal Module can be snapped onto a TH 35 top-hat rail to EN 60715 (IEC 60715).

The signal cable shield can be connected to the TM15 Terminal Module via a shield connection terminal, e.g., Phoenix Contact type SK8 or Weidmüller type KLBÜ CO 1. The shield connection terminal must not be used for strain relief.

The status of the TM15 Terminal Module is indicated via a multi-color LED.

Technical data

TM15 Terminal Module	
Max. current requirement (at 24 V DC) without load	0.15 A
Max. connectable cross section	2.5 mm ²
Max. fuse protection	20 A
Number of DRIVE-CLiQ sockets	2
I/O	
• Digital inputs/outputs	Channelwise parameterizable as DI or DO
• Number of digital inputs/outputs	24
• Isolation	Yes, in groups of 8
• Cables and connections	Plug-in screw-type terminals
• Max. connectable cross section	1.5 mm ²
Digital inputs	
• Voltage	- 30 V to + 30 V
• Low level (an open digital input is interpreted as "low")	- 30 V to + 5 V
• High level	15 V to 30 V
• Current consumption (at 24 V DC)	5 mA to 11 mA
• Signal propagation delays for digital inputs, typical ¹⁾	L → H: 50 μs H → L: 100 μs
Digital outputs (continued-short-circuit-proof)	
• Voltage	24 V DC
• Max. load current per digital output	0.5 A
• Output delay (ohmic load) ¹⁾	
- Typical	L → H: 50 μs H → L: 150 μs
- Maximum	L → H: 100 μs H → L: 225 μs
• Max. total current of outputs (per group)	
- Up to 60 °C (140° F)	2 A
- Up to 50 °C (122° F)	3 A
- Up to 40 °C (104° F)	4 A
Power loss	< 3 W
PE connection	On housing with M4 screw
Width	50 mm (1.97 in)
Height	150 mm (5.91 in)
Depth	111 mm (4.37 in)
Weight, approx.	0.86 kg (2 lb)
Approvals	cULus (File No.: E164110)

Selection and ordering data

Description	Order No.
TM15 Terminal Module (without DRIVE-CLiQ cable)	6SL3055-0AA00-3FA0

¹⁾ The specified signal propagation delays refer to the hardware. The actual reaction time depends on the time slot in which the digital input/output is processed.

Integration

The TM15 Terminal Module communicates with the CU320 Control Unit via DRIVE-CLiQ.

2

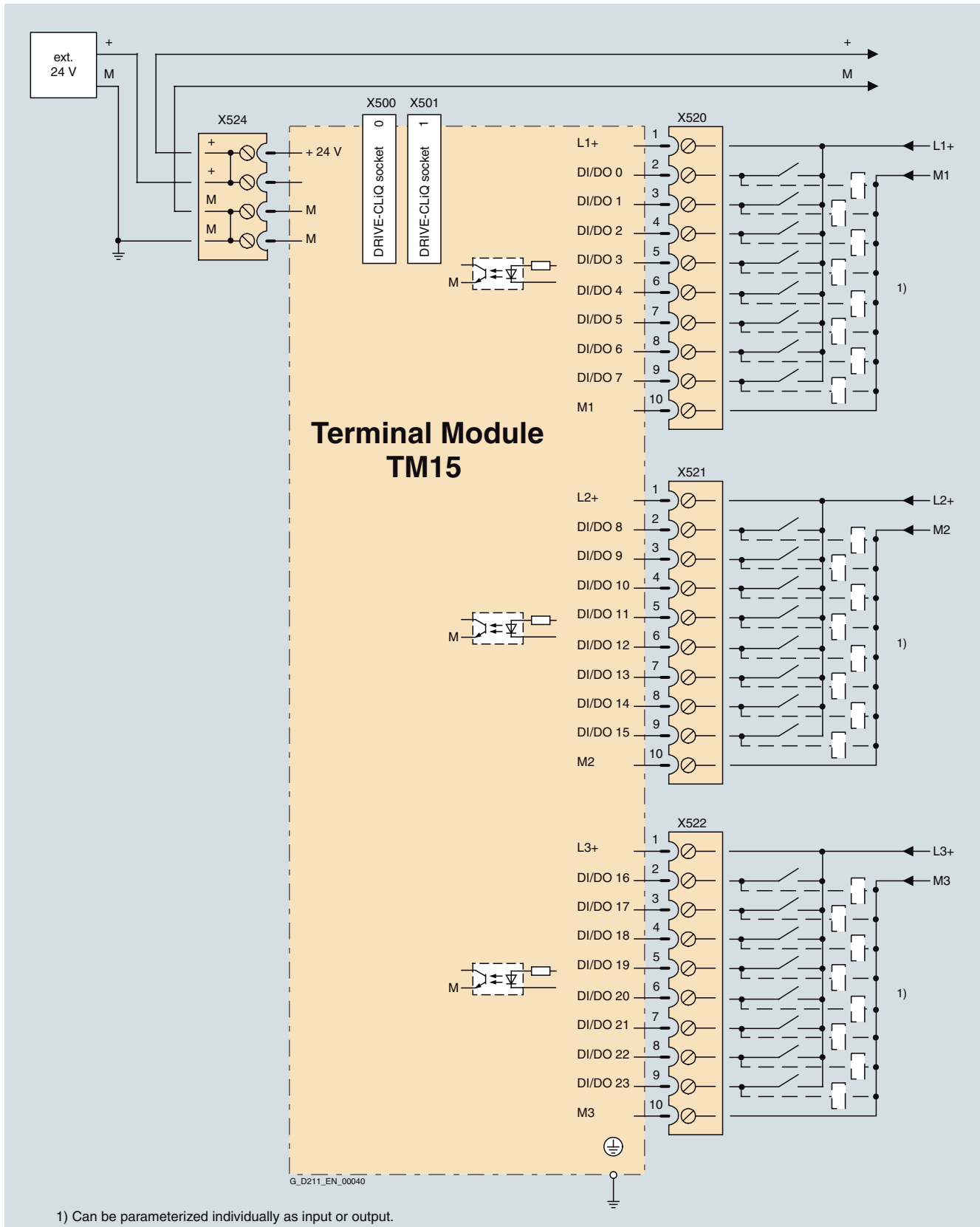

SINAMICS S120

Supplementary system components

TM31 Terminal Module

Overview



With the TM31 Terminal Module, the number of available digital inputs and outputs and the number of analog input and outputs within a drive can be expanded.

The TM31 Terminal Module also features relay outputs with changeover contact and a temperature sensor input.

Design

The following are located on the TM31 Terminal Module:

- 8 digital inputs
- 4 bidirectional digital inputs/outputs
- 2 relay outputs with changeover contact
- 2 analog inputs
- 2 analog outputs
- 1 temperature sensor input (KTY84-130 or PTC)
- 2 DRIVE-CLiQ sockets
- 1 connection for the electronics power supply via the 24 V DC power supply connector
- 1 PE (protective earth) connection

The TM31 Terminal Module can be snapped onto a TH 35 top-hat rail to EN 60715 (IEC 60715).

The signal cable shield can be connected to the TM31 Terminal Module via a shield connection terminal, e.g., Phoenix Contact type SK8 or Weidmüller type KLBÜ CO 1. The shield connection terminal must not be used for strain relief.

The status of the TM31 Terminal Module is indicated via a multi-color LED.

Selection and ordering data

Description	Order No.
TM31 Terminal Module (without DRIVE-CLiQ cable)	6SL3055-0AA00-3AA0

Technical data

TM31 Terminal Module	
Max. current requirement (at 24 V DC), not taking into account digital outputs	0.2 A
Max. connectable cross section	2.5 mm ²
Max. fuse protection	20 A
Digital inputs	
• Voltage	- 3 V to + 30 V
• Low level (an open digital input is interpreted as "low")	- 3 V to + 5 V
• High level	15 V to 30 V
• Current consumption (at 24 V DC)	Type 10 mA
• Signal propagation delays for digital inputs ¹⁾	L → H: approx. 50 μs H → L: approx. 100 μs
• Max. connectable cross section	1.5 mm ²
Digital outputs (continued-short-circuit-proof)	
• Voltage	24 V DC
• Max. load current per digital output	100 mA
• Max. total current of digital outputs	400 mA
• Max. connectable cross section	1.5 mm ²
Analog inputs (a switch is used to toggle between voltage and current input)	
• As voltage input	
- Voltage range	- 10 V to + 10 V
- Internal resistance R_i	100 kOhm
• As current input	
- Current range	4 mA to 20 mA, - 20 mA to + 20 mA, 0 mA to 20 mA
- Internal resistance R_i	250 ohm
- Resolution	11 bit, + sign
• Max. connectable cross section	1.5 mm ²
Analog outputs (continued-short-circuit-proof)	
• Voltage range	- 10 V to + 10 V
• Max. load current	- 3 mA to + 3 mA
• Current range	4 mA to 20 mA, - 20 mA to + 20 mA, 0 mA to 20 mA
• Max. load resistance	500 ohms for outputs in the range - 20 mA to + 20 mA
• Resolution	11 bit, + sign
• Max. connectable cross section	1.5 mm ²
Relay outputs (changeover contacts)	
• Max. load current	8 A
• Max. switching voltage	250 V AC, 30 V DC
• Max. switching power (at 250 V AC)	2000 VA (cos φ = 1) 750 VA (cos φ = 0.4)
• Max. switching power (at 30 V DC)	240 W (ohmic load)
• Required minimum current	100 mA
• Max. connectable cross section	2.5 mm ²
Power loss	< 10 W
PE connection	On housing with M4 screw
Width	50 mm (1.97 in)
Height	150 mm (5.91 in)
Depth	111 mm (4.37 in)
Weight, approx.	0.87 kg (2 lb)
Approvals	cULus (File No.: 164110)

¹⁾ The specified signal propagation delays refer to the hardware. The actual reaction time depends on the time slot in which the digital input is processed.

Integration

The TM31 Terminal Module communicates with the CU320 Control Unit via DRIVE-CLiQ.

2

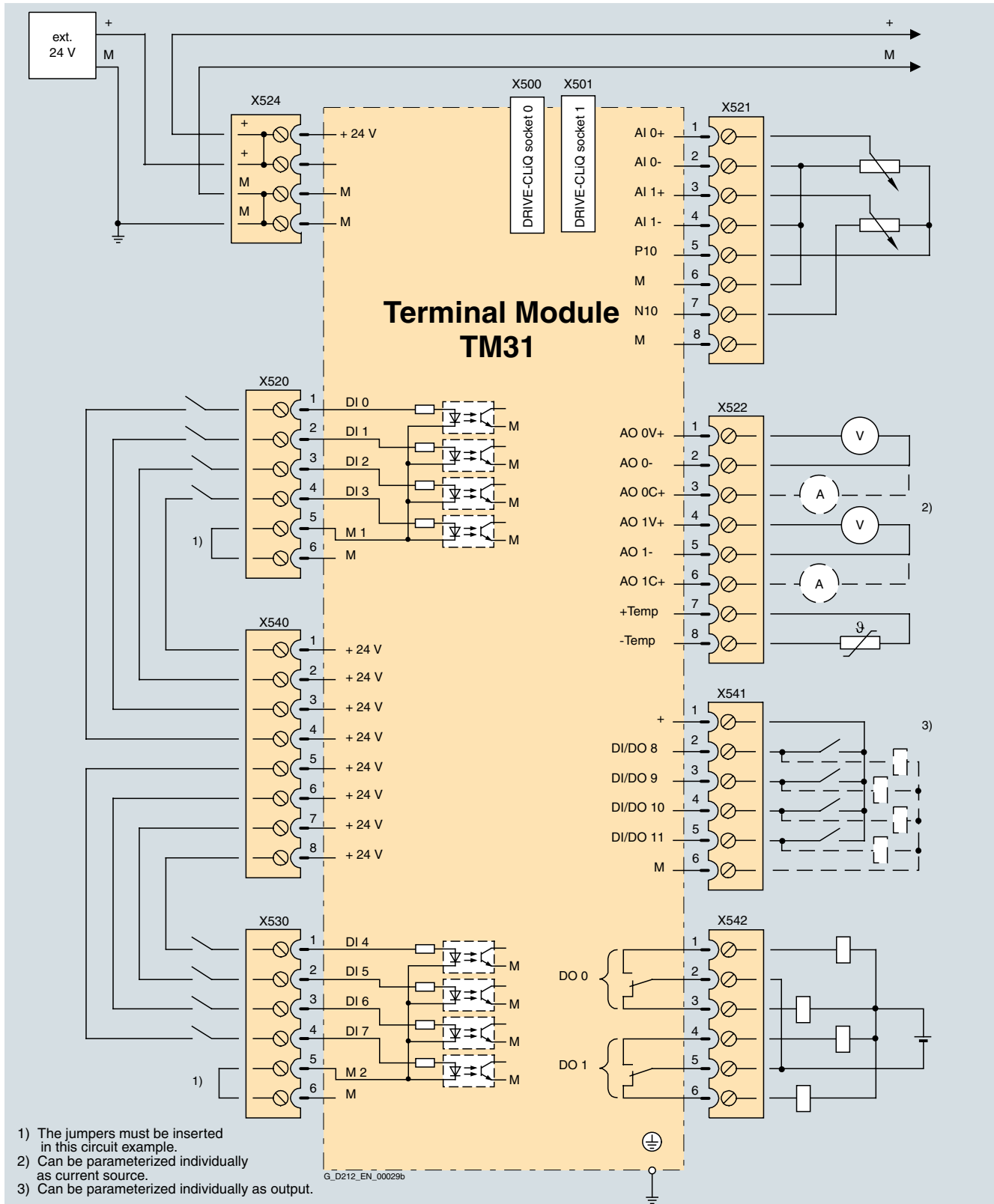

Connection example of TM31 Terminal Module

SINAMICS S120

Supplementary system components

TM41 Terminal Module

Overview



The TM41 Terminal Module supplies TTL signals which simulate an incremental encoder, e.g. to a higher-level control. The encoder interface (incremental encoder simulation) can be linked to an encoder signal from the Control Unit, e.g. incremental encoder sin/cos, by parameter assignment.

The TM41 Terminal Module increases the number of digital inputs/outputs and analog inputs that are available in the drive system.

Design

The following are located on the TM41 Terminal Module:

- 4 bidirectional digital inputs/outputs
- 4 digital inputs (with electrical isolation)
- 1 analog input
- 1 interface for simulation of TTL incremental encoder (RS422)
- 1 LED for signaling zero mark detection for encoder interface
- 2 DRIVE-CLiQ sockets
- 1 connection for the 24 V DC supply to digital outputs
- 1 connection for the electronics power supply via the 24 V DC power supply connector
- 1 PE (protective earth) connection

The TM41 Terminal Module can be snapped onto a TH 35 top-hat rail to EN 60715 (IEC 60715).

The signal cable shield can be connected to the TM41 Terminal Module via a shield connection terminal, e.g., Phoenix Contact type SK8 or Weidmüller type KLBÜ CO 1. The shield connection terminal must not be used for strain relief.

The status of the TM41 Terminal Module is indicated via a multi-color LED.

An LED next to the interface for TTL pulse encoder simulation is illuminated as soon as a zero mark is detected.

Selection and ordering data

Description	Order No.
TM41 Terminal Module (without DRIVE-CLiQ cable)	6SL3055-0AA00-3PA0

Technical data

TM41 Terminal Module	
Current requirement (X524 at 24 V DC) without DRIVE-CLiQ supply or digital outputs (X514)	0.2 A
Max. connectable cross section	2.5 mm ²
Max. fuse protection	20 A
I/O	
• Digital inputs/outputs	Individually parameterizable as DI or DO
• Number of digital inputs/outputs	4
• Number of digital input/outputs (with electrical isolation)	4
• Cables and connections	Plug-in screw-type terminals
• Max. connectable cross section	1.5 mm ²
Digital inputs	
• Voltage	– 3 V to + 30 V (digital inputs without electrical isolation) – 30 V to + 30 V (digital inputs with electrical isolation)
• Low level (an open digital input is interpreted as "low")	– 3 V to + 5 V (digital inputs without electrical isolation) – 30 V to + 5 V (digital inputs with electrical isolation)
• High level	15 V to 30 V
• Current consumption (at 24 V DC), typ.	< 9 mA
• Signal propagation delays for digital inputs, max. ¹⁾	L → H: 3 ms H → L: 3 ms
Digital outputs (continued-short-circuit-proof)	
• Voltage	24 V DC
• Max. load current per digital output	0.5 A
• Output delay (ohmic load) ¹⁾	
- Typical	L → H: 50 μs H → L: 75 μs
- Maximum	L → H: 100 μs H → L: 150 μs
Analog input (difference)	
• Voltage range	– 10 V to + 10 V
• Internal resistance	≥ 40 kOhm
• Resolution	13 bit, + sign
Pulse encoder emulation	
• Level	TTL (RS422), A+, A-, B+, B-, zero track N+, N-
• Limit frequency f_{max} .	256 kHz
• Ratio Encoder pulses : encoder emulation	1 : 1 with incremental encoder sin/cos and TTL/HTL
	(resolver evaluation in preparation)
PE connection	On housing with M4 screw
Width	50 mm (1.97 in)
Height	150 mm (5.91 in)
Depth	111 mm (4.37 in)
Weight, approx.	0.85 kg (2 lb)
Approvals	cULus (File No.: E164110)

¹⁾ The specified signal propagation delays refer to the hardware. The actual reaction time depends on the time slot in which the digital input/output is processed.

Integration

The TM41 Terminal Module communicates with a CU310, CU320 or SIMOTION D Control Unit via DRIVE-CLiQ.

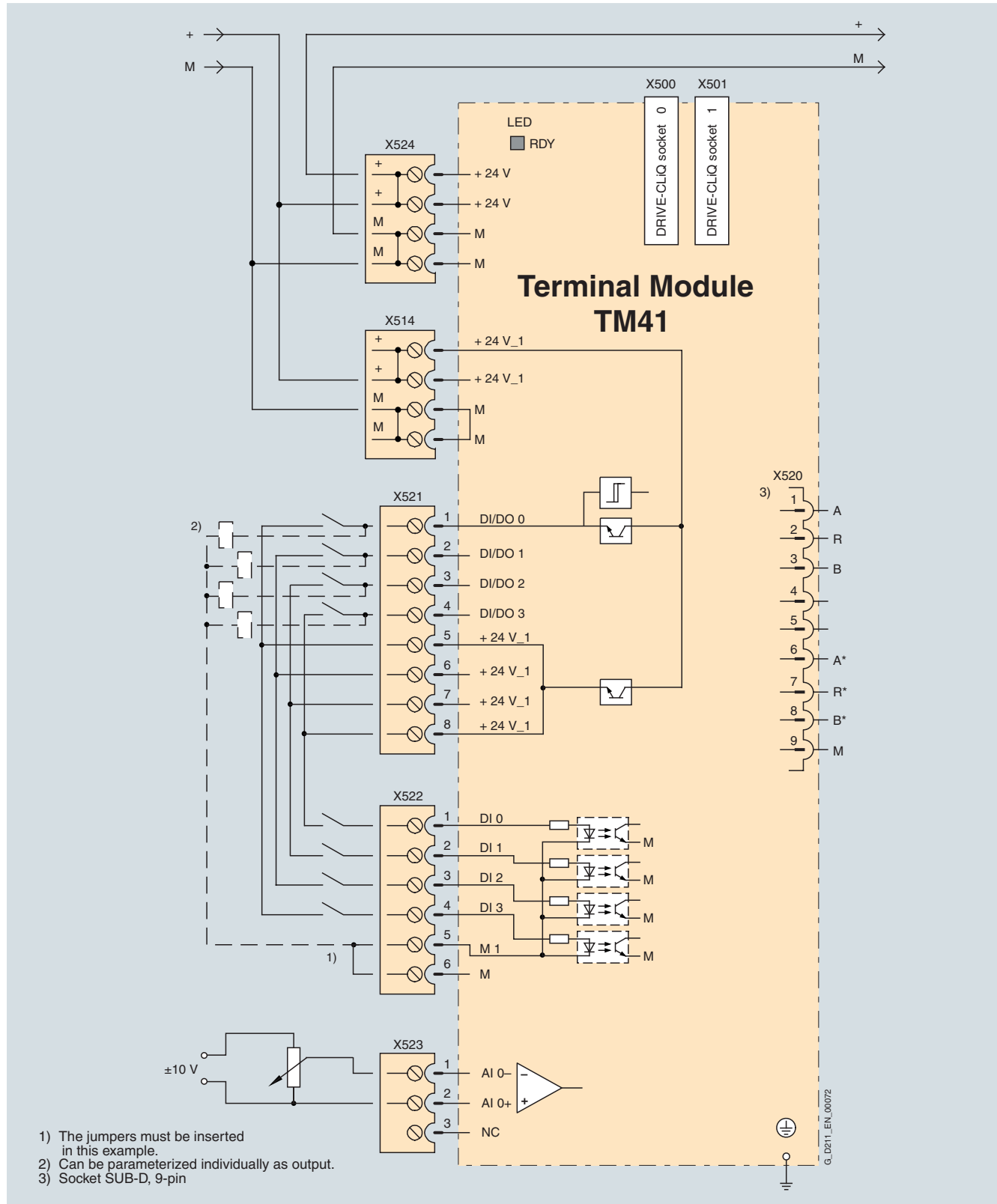

Connection example of TM41 Terminal Module

SINAMICS S120

Supplementary system components

VSM10 Voltage Sensing Module

Overview



The VSM10 Voltage Sensing Module can detect the exact line voltage characteristic and supports fault-free operation of Line Modules when power supply conditions are unfavorable, e.g. with severe voltage fluctuations or short-time interruptions.

The VSM10 Voltage Sensing Module is integrated in chassis format Active Interface Modules. It can be used optionally with all booksize format Active Line Modules and 16 kW or 36 kW Smart Line Modules.

Design

The VSM10 Voltage Sensing Module has the following interfaces:

- 1 connection for direct line voltage detection up to 690 V
- 1 connection for line voltage detection using voltage transformers, maximum voltage 100 V
- 2 analog inputs
- 1 temperature sensor input (KTY84-130 or PTC)
- 1 DRIVE-CLiQ socket
- 1 connection for the electronics power supply via the 24 V DC power supply connector
- 1 PE (protective earth) connection

The VSM10 Voltage Sensing Module can be snapped onto a TH 35 top-hat rail to EN 60715 (IEC 60715).

The status of the VSM10 Voltage Sensing Module is indicated by a two-color LED.

Technical data

VSM10 Voltage Sensing Module	
Max. current requirement (at 24 V DC)	0.15 A
Max. connectable cross section	2.5 mm ²
Power loss, approx.	7.2 W
PE connection	On housing with M4 screw
Width	50 mm (1.97 in)
Height	150 mm (5.91 in)
Depth	111 mm (4.37 in)
Weight, approx.	1.0 kg (2 lb)
Approvals	cULus (File No.: E164110)

Selection and ordering data

Description	Order No.
VSM10 Voltage Sensing Module (without DRIVE-CLiQ cable)	6SL3053-0AA00-3AA0

Integration

The VSM10 Voltage Sensing Module communicates with the CU320 or SIMOTION D Control Unit via DRIVE-CLiQ.

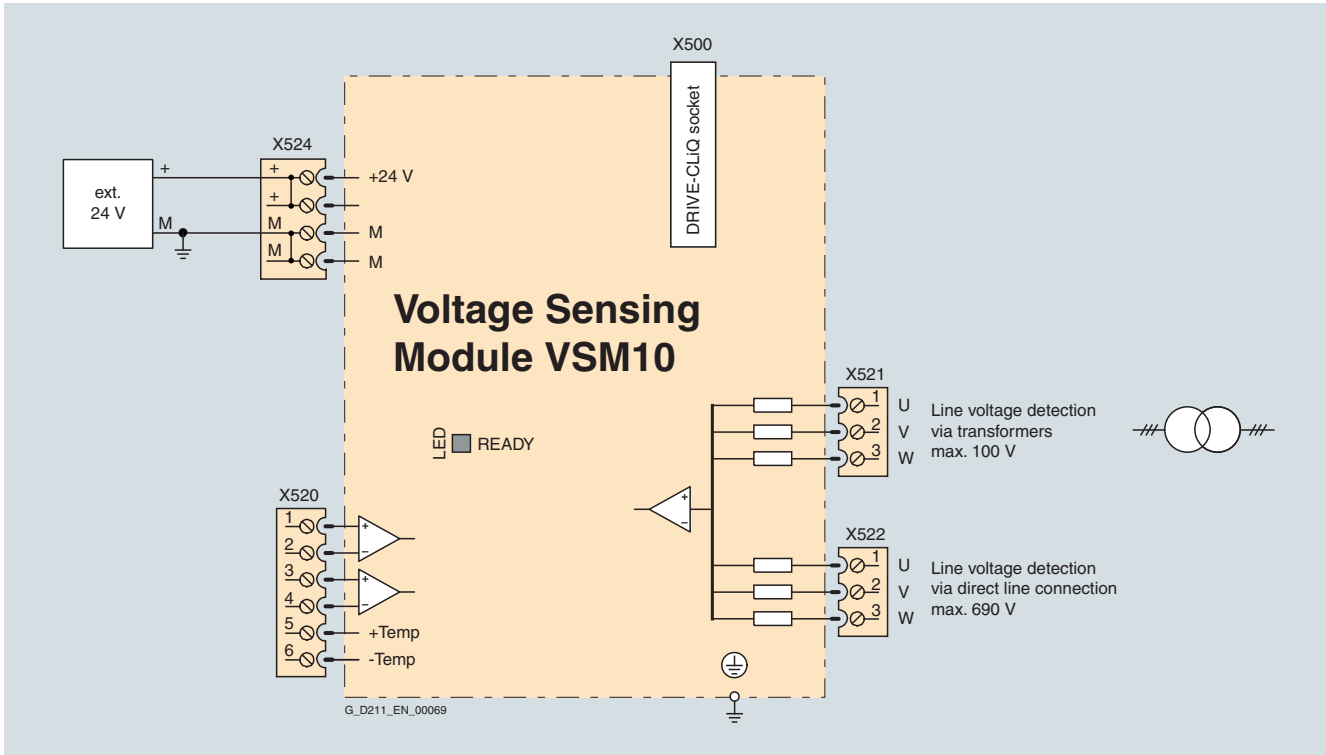

Connection example of VSM10 Voltage Sensing Module

SINAMICS S120

Supplementary system components

Brake Relay/Safe Brake Relay

Overview



Brake Relay and Safe Brake Relay

The Brake Relay in conjunction with Power Modules in blocksize format can be used to control a motor brake.

In the case of the Safe Brake Relay, the brake is controlled in accordance with EN 954-1 safety class 3 and IEC 61508 SIL2 (available soon).

Design

The Brake Relay has the following interfaces:

- 1 switch contact (NO contact) to control the motor brake solenoid
- 1 connection for the cable harness (CTRL) to the Power Module in blocksize format

The Safe Brake Relay has the following interfaces:

- 1 two-channel transistor output stage to control the motor brake solenoid
- 1 connection for the cable harness (CTRL) to the Power Module in blocksize format
- 1 connection for the 24 V DC power supply

The connection between the 24 V DC supply and the Safe Brake Relay must be kept as short as possible.

The Brake Relay or Safe Brake Relay can be installed below the Power Module on the shield connection plate.

The supplied Brake Relay and Safe Brake Relay includes the cable harness (CTRL) for connection with the Power Module.

Technical data

	Brake Relay	Safe Brake Relay
Switching capability of the NO contact	Max. 240 V AC/12 A 30 V DC/2 A	–
Power supply	–	20.4 V to 28.8 V DC Recommended rated supply voltage 26 V DC (to compensate for voltage drop in feeder cable to 24 V DC motor brake solenoid)
Max. permissible current requirement of the motor brake	–	2 A
Max. current requirement (at 24 V DC)	–	0.05 A + the current requirement of motor brake
Max. connectable cross section	2.5 mm ²	2.5 mm ²
Width	69 mm (2.72)	69 mm (2.72)
Height	67.5 mm (2.66)	63 mm (2.66)
Depth	33 mm (1.3)	33 mm (1.3)
Weight, approx.	0.17 kg (0.4 lb)	0.17 kg (0.4 lb)

Selection and ordering data

Description	Order No.
Brake Relay (including cable harness for connection to PM340 Power Module)	6SL3252-0BB00-0AA0
Safe Brake Relay (including cable harness for connection to PM340 Power Module)	6SL3252-0BB01-0AA0

Integration

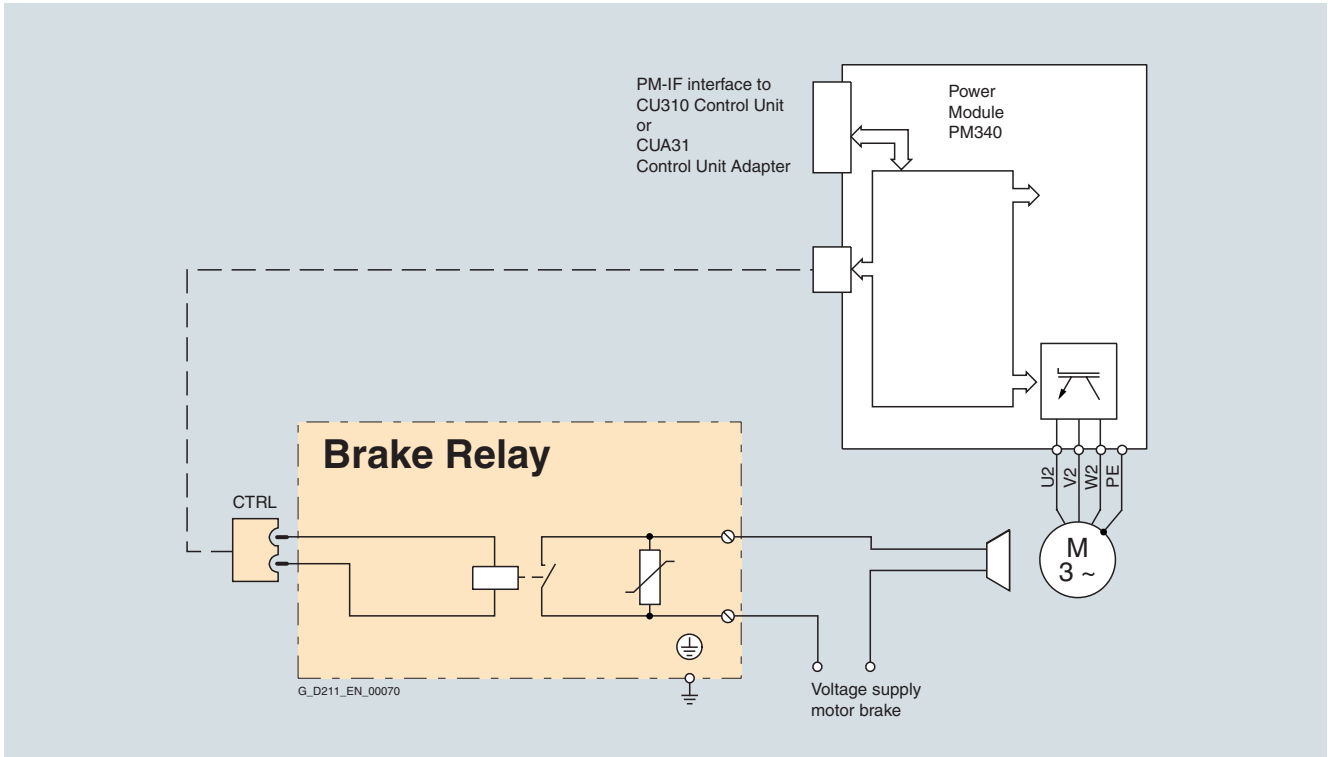

Connection example of Brake Relay

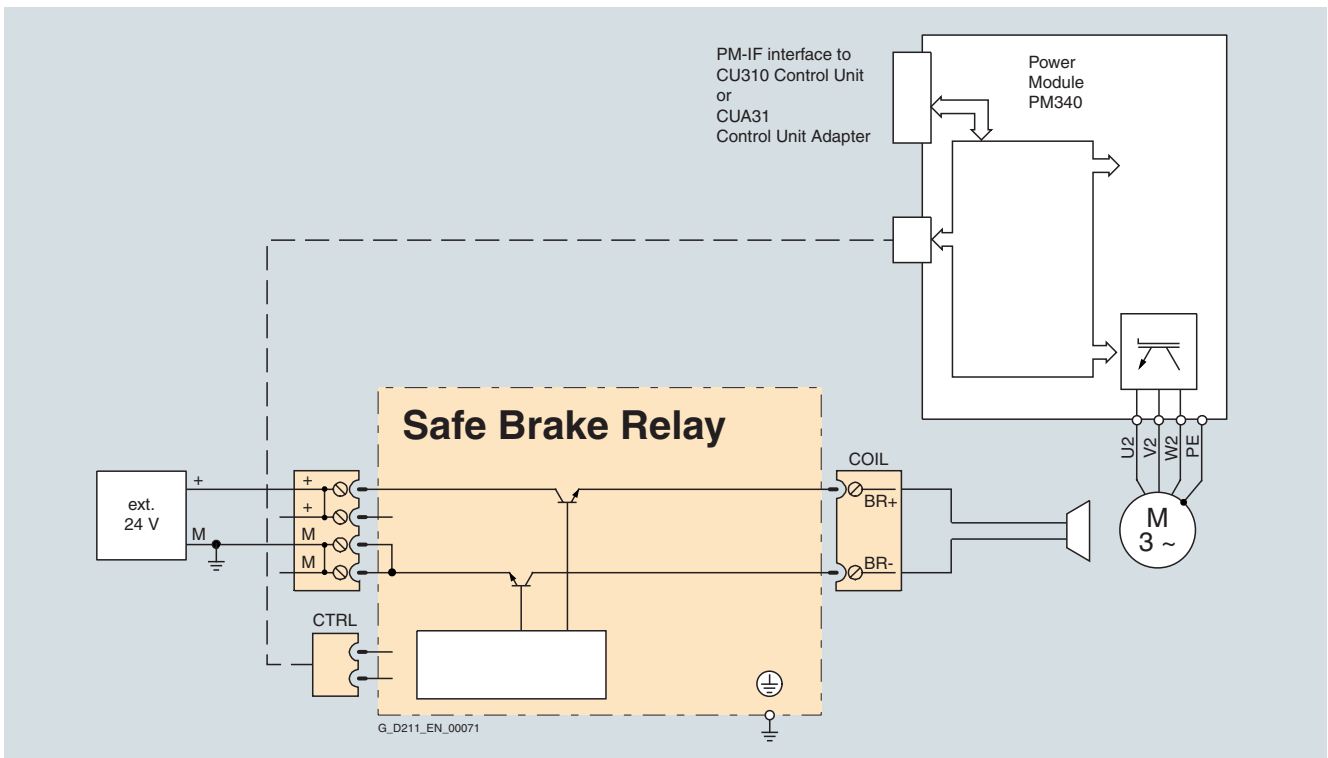

Connection example of Safe Brake Relay

The 24 V DC solenoid of the motor brake is directly connected to the Safe Brake Relay. External overvoltage limiters are not required.

SINAMICS S120

Encoder system connection

Encoder system connection

Overview

Motors with DRIVE-CLiQ interface

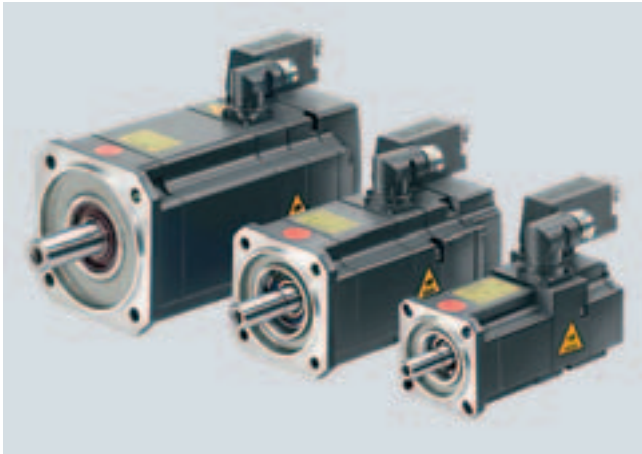

DRIVE-CLiQ is the preferred method for connecting the encoder systems to SINAMICS S120.

Motors with DRIVE-CLiQ interface can be ordered for this purpose, for example, 1FK7/1FT6 synchronous motors, 1FW3 torque motors and 1PH7, 1PL6 and 1PH4 asynchronous motors.

Motors with DRIVE-CLiQ interface can be directly connected to the associated Motor Module via the available MOTION-CONNECT DRIVE-CLiQ cables. The connection of the MOTION-CONNECT DRIVE-CLiQ cable at the motor has degree of protection IP67.

The DRIVE-CLiQ interface supplies the motor encoder via the integrated 24 V DC supply and transfers the motor encoder and temperature signals and the electronic rating plate data, e.g. a unique identification number, rated data (voltage, current, torque) to the Control Unit. This means that for the various encoder types – e.g. resolver or absolute encoder – different encoder cables with varying permissible lengths are now no longer required; just one cable type, MOTION-CONNECT DRIVE-CLiQ, can be used for all encoders.

These motors simplify commissioning and diagnostics, as the motor and encoder type are identified automatically.

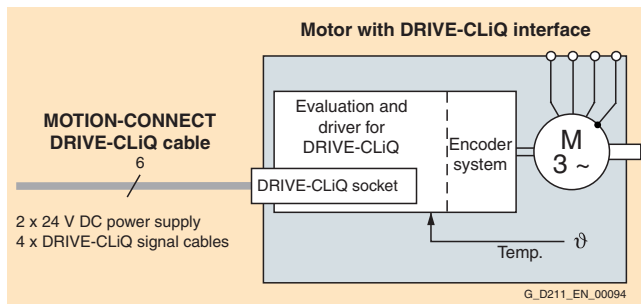

Motors without DRIVE-CLiQ interface

The encoder and temperature signals of motors without DRIVE-CLiQ interface, as well as those of external encoders, must be connected via Sensor Modules. Sensor Modules Cabinet-Mounted are available in degree of protection IP20 for control cabinet installation, as well as Sensor Modules External-Mounted (degree of protection IP67).

Only one encoder system can be connected to each Sensor Module.

Technical data for motors with DRIVE-CLiQ interface

Motors with DRIVE-CLiQ interface and resolver (2-pole/multi-pole), incremental encoder sin/cos 1 V _{pp} , absolute encoder EnDat (512 pulses/revolution, 2048 pulses/revolution) or single absolute encoder	
Max. current requirement at 24 V DC (via Motor Module and MOTION-CONNECT DRIVE-CLiQ cable)	190 mA
Max. DRIVE-CLiQ cable length	<ul style="list-style-type: none"> • 100 m (328 ft) when using MOTION-CONNECT 500 DRIVE-CLiQ cables • 50 m (164 ft) when using MOTION-CONNECT 800 DRIVE-CLiQ cables

Further information

Motor encoder and temperature signals must be connected to the corresponding Motor Module or Power Module and external encoders to the Control Unit.

Overview



The SMC10 Sensor Module Cabinet-Mounted is required to evaluate the encoders of motors without a DRIVE-CLiQ interface. External encoders can also be connected via the SMC10.

The following encoder signals can be evaluated:

- 2-pole resolver
- Multi-pole resolver

Design

The SMC10 Sensor Module Cabinet-Mounted features the following interfaces as standard:

- 1 DRIVE-CLiQ interface
- 1 encoder connection including motor temperature detection (KTY84-130 or PTC) via SUB-D connector
- 1 connection for the electronics power supply via the 24 V DC power supply connector
- 1 PE (protective earth) connection

The status of the SMC10 Sensor Module Cabinet-Mounted is indicated via a multi-color LED.

The SMC10 Sensor Module Cabinet-Mounted can be snapped onto a TH 35 top-hat rail to EN 60715 (IEC 60715).

The maximum encoder cable length between SMC10 modules and encoders is 130 m (427 ft).

Integration

The SMC10 Sensor Module Cabinet-Mounted communicates with the CU320 Control Unit via DRIVE-CLiQ.

Technical data

SMC10 Sensor Module Cabinet-Mounted

Max. current requirement (at 24 V DC) not taking encoder into account	0.2 A
Max. connectable cross section	2.5 mm ²
Max. fuse protection	20 A
Power loss	< 10 W
PE connection	On housing with M4 screw
Width	50 mm (1.97 in)
Height	150 mm (5.91 in)
Depth	111 mm (4.37 in)
Weight, approx.	0.8 kg (2 lb)

Selection and ordering data

Description	Order No.
SMC10 Sensor Module Cabinet-Mounted (without DRIVE-CLiQ cable)	6SL3055-0AA00-5AA0

SINAMICS S120

Encoder system connection

SMC20 Sensor Module Cabinet-Mounted

Overview



The SMC20 Sensor Module Cabinet-Mounted is required to evaluate the encoders of motors without a DRIVE-CLiQ interface. External encoders can also be connected via the SMC20.

The following encoder signals can be evaluated:

- Incremental encoder sin/cos 1 V_{pp}
- Absolute encoder EnDat
- SSI encoder with incremental signals sin/cos 1 V_{pp} (firmware version 2.4 and later)

The motor temperature can also be detected using KTY84-130 or PTC thermistors.

Design

The SMC20 Sensor Module Cabinet-Mounted features the following interfaces as standard:

- 1 DRIVE-CLiQ interface
- 1 encoder connection, including motor temperature detection (KTY84-130 or PTC) via SUB-D connector
- 1 connection for the electronics power supply via the 24 V DC power supply connector
- 1 PE (protective earth) connection

The status of the SMC20 Sensor Module Cabinet-Mounted is indicated via a multi-color LED.

The SMC20 Sensor Module Cabinet-Mounted can be snapped onto a TH 35 top-hat rail to EN 60715 (IEC 60715).

The maximum encoder cable length between SMC20 modules and encoders is 100 m (328 ft).

Integration

The SMC20 Sensor Module Cabinet-Mounted communicates with the CU320 Control Unit via DRIVE-CLiQ.

Technical data

SMC20 Sensor Module Cabinet-Mounted

Power supply for encoder	5 V DC
Max. current requirement (at 24 V DC) not taking encoder into account	0.2 A
Max. connectable cross section	2.5 mm ²
Max. fuse protection	20 A
Power loss	< 10 W
PE connection	On housing with M4 screw
Width	50 mm (1.97 in)
Height	150 mm (5.91 in)
Depth	111 mm (4.37 in)
Weight, approx.	0.8 kg (2 lb)

Selection and ordering data

Description	Order No.
SMC20 Sensor Module Cabinet-Mounted (without DRIVE-CLiQ cable)	6SL3055-0AA00-5BA1

Overview



The SMC30 Sensor Module Cabinet-Mounted is required to evaluate the encoders of motors without a DRIVE-CLiQ interface. External encoders can also be connected via the SMC30.

The following encoder signals can be evaluated:

- Incremental encoders TTL/HTL with/without open-circuit detection
- SSI encoders with incremental signals TTL/HTL (firmware version V2.4 and later)
- SSI encoders without incremental signals (firmware version V2.4 and later)

The motor temperature can also be detected using KTY84-130 or PTC thermistors.

Design

The SMC30 Sensor Module Cabinet-Mounted features the following interfaces as standard:

- 1 DRIVE-CLiQ interface
- 1 encoder connection including motor temperature detection (KTY84-130 or PTC) via SUB-D connector
- 1 connection for the electronics power supply via the 24 V DC power supply connector
- 1 PE (protective earth) connection

The status of the SMC30 Sensor Module Cabinet-Mounted is indicated via a multi-color LED.

The SMC30 Sensor Module Cabinet-Mounted can be snapped onto a TH 35 top-hat rail to EN 60715 (IEC 60715).

The maximum encoder cable length between SMC30 modules and encoders is 100 m (328 ft). For HTL encoders, this length can be increased to 300 m (984 ft) if signals A+/A- and B+/B- are evaluated and the power supply cable has a minimum cross section of 0.5 mm².

The signal cable shield can be connected to the SMC30 Sensor Module Cabinet-Mounted via a shield connection terminal, e.g., Phoenix Contact type SK8 or Weidmüller type KLBÜ CO 1.

Integration

The SMC30 Sensor Module Cabinet-Mounted communicates with the CU320 Control Unit via DRIVE-CLiQ.

Technical data

SMC30 Sensor Module Cabinet-Mounted	
Power supply for encoder	5 V DC and 24 V DC
Max. current requirement (at 24 V DC) not taking encoder into account	0.2 A
Max. connectable cross section	2.5 mm ²
Max. fuse protection	20 A
Power loss	< 10 W
Cut-off frequency	500 kHz
Resolution absolute position SSI	30 bit
Max. cable length	
• TTL encoders	Max. 100 m (328 ft) (only bipolar signals permitted)
• HTL encoders	Max. 100 m (328 ft) for unipolar signals Max. 300 m (984 ft) for bipolar signals
PE connection	On housing with M4 screw
Width	50 mm (1.97 in)
Height	150 mm (5.91 in)
Depth	111 mm (4.37 in)
Weight, approx.	0.8 kg (2 lb)

Selection and ordering data

Description	Order No.
SMC30 Sensor Module Cabinet-Mounted (without DRIVE-CLiQ cable)	6SL3055-0AA00-5CA1

SINAMICS S120

Encoder system connection

SME20/SME25 Sensor Modules External

Overview



SME20/SME25 Sensor Modules External are encoder evaluation units for machine encoders (direct measuring systems). The devices are designed with IP67 degree of protection. This means that the units can be installed outside the control cabinet near the machine encoder.

The following encoder signals can be evaluated:

- Incremental encoder sin/cos 1 V_{pp} without rotor position track (C/D track)
- Absolute encoder EnDat
- Absolute encoder SSI with incremental signals sin/cos 1 V_{pp} (firmware version 2.4 and later)

SME20/SME25 Sensor Modules External evaluate the encoder signals and convert the information obtained to DRIVE-CLiQ.

Design

SME20/SME25 Sensor Modules External feature the following interfaces as standard:

- 1 DRIVE-CLiQ interface
- 1 encoder connector (circular plug)
- 24 V DC electronics power supply via DRIVE-CLiQ link from the Control Unit/Motor Module
- 1 PE (protective earth) connection

The maximum cable length between the measuring system and SME20/SME25 modules is 3 m (9.84 ft).

The maximum cable length between SME20/SME25 modules and the drive control is 100 m (328 ft).

Integration

SME20/SME25 Sensor Modules External communicate with a Control Unit via DRIVE-CLiQ.

Selection and ordering data

Description	Order No.
SME20 Sensor Module External for incremental measuring systems (without DRIVE-CLiQ cable)	6SL3055-0AA00-5EA0
SME25 Sensor Module External for absolute systems (without DRIVE-CLiQ cable)	6SL3055-0AA00-5HA0

Technical data

	SME20 Sensor Module External	SME25 Sensor Module External
Encoder	• Incremental encoder sin/cos 1 V _{pp} with 5 V voltage supply	• Absolute encoder EnDat with 5 V voltage supply • Absolute encoder SSI with incremental signals sin/cos 1 V _{pp} with 5 V voltage supply
Multiplication factor	2048	2048
Measuring system interface	12-pin circular connector	17-pin circular connector
Outlet	IP67 DRIVE-CLiQ connector	IP67 DRIVE-CLiQ connector
Max. current requirement (at 24 V DC) not taking encoder into account	0.11 A	0.11
Max. cross section that can be connected	Acc. to connector contacts	Acc. to connector contacts
Max. fuse protection	via DRIVE-CLiQ power supply source	via DRIVE-CLiQ power supply source
Power loss	W < 10	< 10
PE connection	On housing with M4/1.8 Nm screw	On housing with M4/1.8 Nm screw
Degree of protection	IP67	IP67
Width	mm (inch) 58 (2.28)	58 (2.28)
Height	mm (inch) 44 (1.73)	44 (1.73)
Depth	mm (inch) 112 (4.41)	112 (4.41)
Weight, approx.	kg (lb) 0.18 (0.4)	0.18 (0.4)





AC motors



3	AC motors	3/111	1PH7/1PL6 Asynchronous motors
3/2	Overview of types and rated data	3/111	Overview
3/6	Technical definitions	3/112	1PH7 motors
3/12	Encoder systems	3/138	Permissible combinations of mechanical designs for 1PH7 motors, shaft height 280
3/14	1FT6/1FK7 Synchronous motors	3/140	1PL6 motors
3/14	1FT6 motors	3/154	Permissible combinations of mechanical designs for 1PL6 motors, shaft heights 225 and 280
3/38	1FK7 motors	3/158	Selection guides
<u>3/46</u>	<u>Gearboxes</u>	<u>3/158</u>	<u>For 1PH7 and 1PL6 motors</u>
3/46	Series SP+ planetary gearbox for 1FT6 motors	3/158	Ventilation data/sound pressure level
3/51	Series SP+ planetary gearbox for 1FK7 motors	3/159	Bearing design and bearing service life
3/56	Series LP+ planetary gearbox for 1FK7 motors	3/160	Cantilever force diagrams
3/58	1FK7 Geared motors	3/162	Mounting position
3/58	1FK7-DYA compact geared motors	<u>3/163</u>	<u>For 1PH7 motors</u>
3/62	1FK7 geared servo motors	3/163	Terminal box assignments/cable cross sections
3/96	1FS6/1FW3 Synchronous motors	3/164	Mounted holding brakes
3/96	1FS6 motors, explosion-protected	<u>3/166</u>	<u>For 1PL6 motors</u>
3/100	1FW3 torque motors	3/166	Terminal box assignments/cable cross sections
3/108	Selection Guides	3/167	1PH4 Asynchronous motors
3/108	Built-in holding brake for 1FK7 and 1FT6 motors	3/167	1PH4 motors, water cooling
3/109	Types/mounting position, degree of protection	3/176	Dimension drawings
3/110	Options	<u>3/176</u>	<u>Synchronous motors</u>
		3/176	1FT6 motors
		3/188	1FT6 Big Servo motors
		3/190	1FK7 Compact motors
		3/192	1FK7 High Dynamic motors
		3/193	1FT6 motors with SP+ planetary gearbox
		3/198	1FK7 motors with SP+ planetary gearbox
		3/203	1FK7 motors with LP+ planetary gearbox
		3/206	1FK7-DYA motors
		3/207	1FS6 motors
		3/208	1FW3 torque motors
		<u>3/214</u>	<u>Asynchronous motors</u>
		3/214	1PH7 motors
		3/231	1PL6 motors
		3/238	1PH4 motors

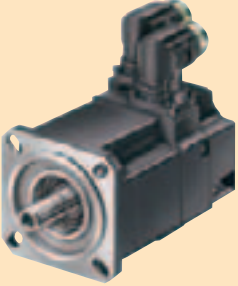

Synchronous motors

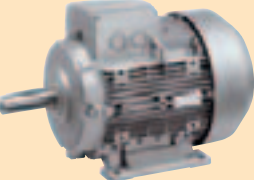

	Motor types	Designation / Method of functioning	Degree of protection	Cooling
	1FK7 Compact	Compact servomotor Chassis-type Frameless permanent-magnet synchronous motor	IP64 (IP65 optional)	Natural cooling
	1FK7 High Dynamic	High Dynamic servomotor with extremely low intrinsic moment of inertia	IP64 (IP65 optional)	Natural cooling
	1FK7	Geared motor	IP65	Natural cooling
	1FK7-DYA	Compact geared motor 1FK7-DYA	IP64	Natural cooling
 	1FT6	Servomotor – High Performance Permanent-magnet synchronous motor	IP64 (IP65, IP67, IP68 optional)	Natural cooling Forced ventilation Water cooling
	1FS6 	Servomotor – explosion-proof Permanent-magnet synchronous motor with EEx de II C T3 explosion protection	IP64 (IP65 optional)	Natural cooling
	1FW3	Torque motor Liquid-cooled, permanent-magnet synchronous motor	IP54	Water cooling
	1FU8	SIEMOSYN motor Permanent-magnet synchronous motor	IP54 (2-pole) IP55 (4/6-pole)	Natural cooling

Overview of types and rated data

Synchronous motors

Shaft height	Power range in kW (HP)	Rated torque	Selection / ordering data on pages
20 to 100	0.05 (0.07) 8.2 (11)	0.08 to 37 Nm (0.7 to 327 lb _f -in)	3/40 to 3/41
36 to 80	0.6 (0.8) 3.1 (4.2)	0.9 to 12 Nm (8 to 106 lb _f -in)	3/42 to 3/45
36 to 100	0.3 (0.4) 8.0 (10.7)	58 to 1370 Nm (43 to 1011 lb _f -ft)	3/64 to 3/85
36 to 80	0.4 (0.5) 1.9 (2.6)	6.5 to 70 Nm (57.5 to 619.5 lb _f -in)	3/60 to 3/61
28 to 132	0.2 (0.3) 15.5 (21)	0.3 to 88 Nm (2.7 to 779 lb _f -in)	3/16 to 3/27
80 to 160	6.9 (9.3) 89 (119)	17 to 540 Nm (151 to 4779 lb _f -in)	3/28 to 3/33
63 to 160	3.2 (4.3) 118 (158)	10 to 690 Nm (89 to 6107 lb _f -in)	3/34 to 3/37
71 to 132	1.2 (1.6) 12.4 (16.6)	1.9 to 68 Nm (17 to 602 lb _f -in)	3/98 to 3/99
150 200 280	3.1 (4.2) 177 (237)	100 to 7000 Nm (74 to 5163 lb _f -ft)	3/102 to 3/107
71 to 160	0.31 (0.4) 22.9 (31)	1.3 to 59.6 Nm (11.5 to 528 lb _f -in)	see Catalog DA 48

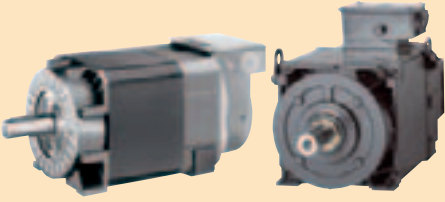
Asynchronous motors

Motor types	Designation / Method of functioning	Degree of protection	Cooling
1PH7 	Asynchronous servomotor Frameless three-phase squirrel-cage motor	IP55	Forced ventilation Surface cooling
1PL6 	Asynchronous servomotor Frameless three-phase squirrel-cage motor	IP23	Forced ventilation Axial ventilation
1PH4 	Asynchronous servomotor Liquid-cooled three-phase squirrel-cage motor	IP65	Water cooling

Overview of types and rated data

Asynchronous motors

Shaft height	Power range in kW (HP)							Rated torque	Selection / ordering data on pages	
	0.01	0.1	1	10	100	1000				
100 to 280					3.7 (5)		385 (516)	22 to 2480 Nm (18 to 1829 lb _f -ft)	3/114 to 3/137	
180 to 280							20.5 (28)	630 (845)	370 to 3600 Nm (373 to 2655 lb _f -ft)	3/142 to 3/153
100 to 160							7.5 (10)	65 (87)	45 to 333 Nm (33 to 246 lb _f -ft)	3/170 to 3/175

Technical definitions

Regulations, standards and specifications

The motors comply with the appropriate standards and regulations, see table below.

As a result of the fact that in many countries the national regulations have been completely harmonized with the international IEC 60034-1 recommendation, there are no longer any differences with respect to coolant temperatures, temperature classes and maximum temperature rises.

The motors listed below are UL-approved by "Underwriters Laboratories Inc.®" and also comply with Canadian URc standards: 1FK7, 1FT6, 1FW3, 1PH7 (without brake), 1PL6, 1PH4.

1FS6 EX motors are CSA - approved.

Title	DIN/VDE	DIN IEC
General specifications for rotating electrical machines	DIN VDE 0530 Part 1	DIN IEC 60034-1
Terminal designations and direction of rotation for electrical machines	DIN VDE 0530 Part 8	DIN IEC 60034-8
Types of construction of rotating electrical machines	DIN VDE 0530 Part 7	DIN IEC 60034-7
Cooling methods of rotating electrical machines	DIN VDE 0530 Part 6	DIN IEC 60034-6
Degrees of protection of rotating electrical machines	DIN VDE 0530 Part 5	DIN IEC 60034-5
Vibration severity of rotating electrical machines	DIN VDE 0530 Part 14	DIN IEC 60034-14
Noise limit values for rotating electrical machines	DIN VDE 0530 Part 9	DIN IEC 60034-9
Cylindrical shaft ends for electrical machines	DIN 748 Part 3	DIN IEC 60072

The most common degrees of protection for AC motors according to IEC 60034-5

A suitable degree of protection must be selected to protect the machine against the following hazards depending on the relevant operating and environmental conditions:

- Ingress of water, dust and solid foreign objects;
- Contact with or approach to rotating parts inside a motor and
- Contact with or approach to live parts.

Degrees of protection of electric motors are specified by a code. This comprises of 2 letters, 2 digits and, if required, an additional letter.

IP (International Protection)

Code letter designating the degree of protection against contact and the ingress of solid foreign objects and water

0 to 6

1st digit designating the degree of protection against contact and ingress of solid foreign objects

0 to 8

2nd digit designating the degree of protection against ingress of water (no oil protection)

W, S and M

Additional code letter for special degrees of protection

Most motors are supplied with the following degrees of protection:

Motor	Degree of protection	1st digit Protection against accidental contact	Protection against foreign objects	2nd digit Protection against water
Internally cooled	IP23	Protection against finger contact	Protection against medium-sized, solid foreign bodies above 12 mm (0.47 in) Ø	Protection against spray water up to 60° from the vertical
Surface-cooled	IP54	Complete protection against accidental contact	Protection against harmful dust deposits	Splash-water from any direction
	IP55			Jet-water from any direction
	IP64	Complete protection against accidental contact	Protection against dust ingress	Splash-water from any direction
	IP65 ¹⁾			Jet-water from any direction
	IP67 ¹⁾			Motor under specified pressure and time conditions under water
IP68 ¹⁾			Motor can be completely submersed in water under conditions which the manufacturer must specify	

¹⁾ DIN VDE 0530 Part 5 or EN 60034 Part 5 specifies that there are only 5 degrees of protection for the first digit code and 8 degrees of protection for the second digit code in relation to rotating electrical machinery. However, IP6 is included in DIN 40 050 which generally applies to electrical equipment.

Radial eccentricity tolerance, shaft and flange accuracy (concentricity and axial eccentricity) according to IEC 60072

Radial eccentricity tolerance of shaft in relation to housing axis (refers to cylindrical shaft ends)

Shaft height	Standard N mm/in	Option R mm/in
28, 36	0.035/0.001	0.018/0.001
48, 63, 71	0.04/0.002	0.021/0.001
80, 100, 132	0.05/0.002	0.025/0.001
160, 180, 225	0.06/0.002	0.03/0.001
280	0.07/0.003	0.035/0.001

Concentricity and axial eccentricity tolerance of the flange surface to the shaft axis (referred to the centering diameter of the mounting flange)

Shaft height	Standard N mm/in	Option R mm/in
28, 36, 48	0.08/0.003	0.04/0.002
63, 71, 80, 100	0.1/0.004	0.05/0.002
132, 160, 180, 225	0.125/0.005	0.063/0.002
280	0.16/0.006	0.08/0.003

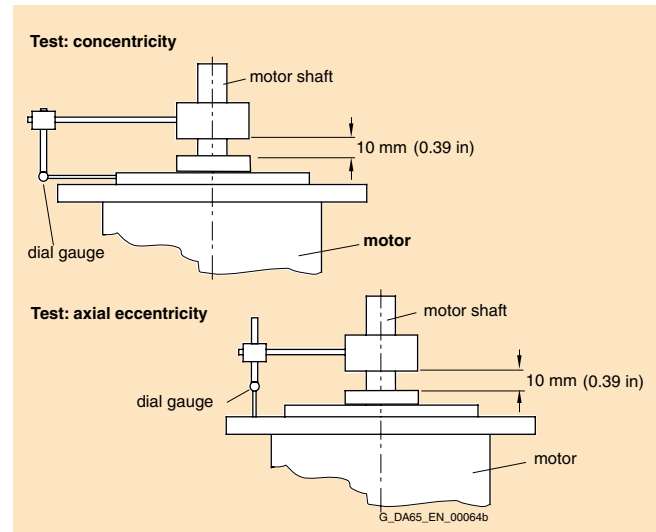
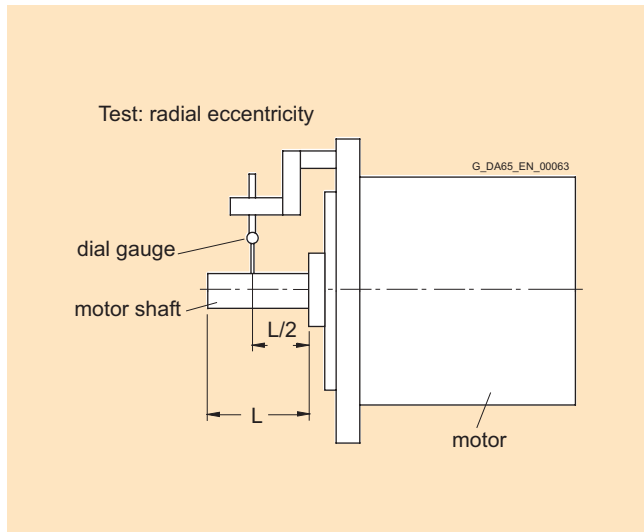

Vibration severity grades acc. to DIN IEC 60034-14

The vibration severity is the RMS value of the vibration velocity (frequency range from 10 to 1000 Hz). The vibration severity is measured using electrical measuring instruments in compliance with DIN 45 666.

The values indicated refer only to the motor. These values can increase as a result of the overall system vibrational behavior due to installation.

The speeds of 1800 rpm and 3600 rpm and the associated limit values are defined in accordance with IEC 60034-14. Speeds of 4500 rpm and 6000 rpm and the specified values are defined by the motor manufacturer.

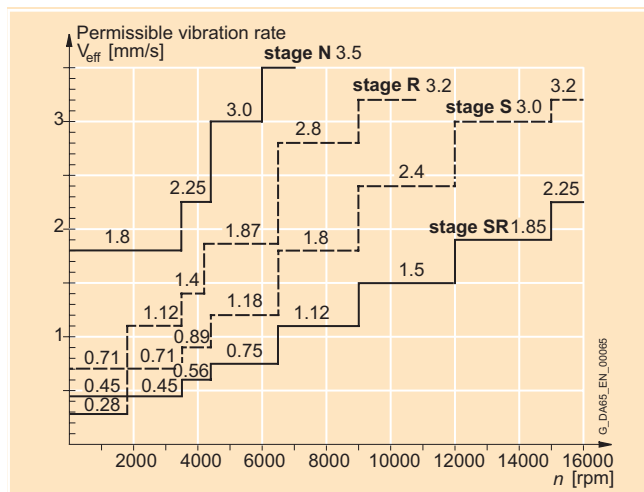

Vibration severity grade limit values for shaft heights 20 to 132

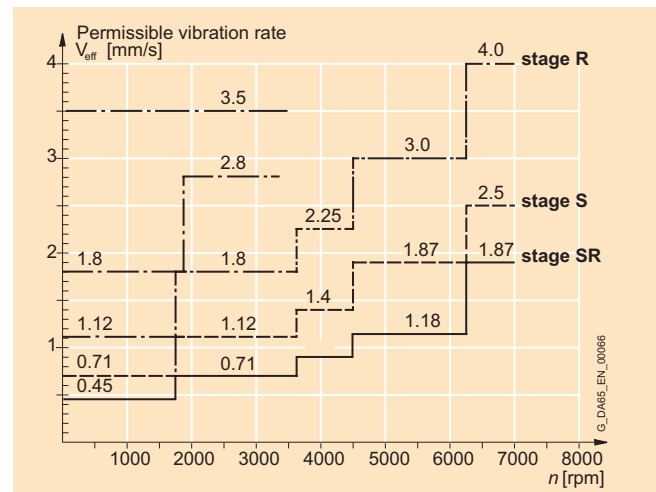

Vibration severity grade limit values for shaft heights 160 to 280

Technical definitions

Balancing in accordance with DIN ISO 8821

Requirements placed on the process when balancing mounted components - especially belt pulleys

The vibrational quality of motors with attached belt pulleys, in addition to the motor's balance quality, is mainly determined by the balance state of the mounted component.

If the motor and the mounted component are balanced separately before being joined, the balancing process of the belt pulley is to be adapted to the motor's balancing type. The following different balancing methods are used on motors of types 1PH4, 1PH7 and 1PL6:

- Half-key balancing
- Full-key balancing
- Keyless shaft end

The balancing method is encoded in the order designation for 1PH7 and 1PL6 motors. The letter "H" (half key) or "F" (full key) is printed on the shaft end face to identify a half-key balanced or a full-key balanced motor.

1FK7 and 1FT6 motors with featherkey are always half-key balanced.

In general, motors with a keyless shaft are recommended for systems with the most stringent vibrational quality requirements. For full-key balanced motors, we recommend belt pulleys with two opposite featherkey ways, but only one featherkey in the shaft end.

Vibration stress, immitted vibration values

The following maximum permissible vibration stress limits at full reliability performance apply only to 1FK7, 1FT6 and 1FS6 permanent-field synchronous motors.

Vibration stress (in accordance with DIN ISO 10816):

- 1 g (20 Hz to 2 kHz)

The following limits are valid for (immitted) vibration values introduced externally to all asynchronous motors of type 1PH7, 1PH4 and 1PL6:

Vibration frequency	Vibration values for	Shaft heights	
		100 to 160	180 to 280
<6.3 Hz	Vibration displacement s	≤ 0.16 mm (0.01 in)	≤ 0.25 mm (0.01 in)
6.3 ... 63 Hz	Vibration velocity V_{eff}	≤ 4.5 mm/s (0.18 in/s)	≤ 7.1 mm/s (0.28 in/s)
>63 Hz	Vibration acceleration a	≤ 2.55 m/s ² (8.37 ft/s ²)	≤ 4.0 m/s ² (13.12 ft/s ²)

Coolant temperature (air) and installation altitude

Operation (unrestricted) CT = -15 °C to +40 °C (5 °F to 104 °F)

The rated power (rated torque) is applicable to continuous duty (S1) in accordance with EN 60034-1 at rated frequency, a coolant temperature (CT) of 40 °C (104 °F) and an installation altitude of 1000 m (3281 ft) above sea level.

All motors are Thermal Class F and utilized in accordance with Thermal Class F. For all other conditions, the factors given in the table on the right must be applied to determine the permissible output (torque).

The coolant temperature and installation altitude are rounded to 5 °C (41 °F) and 500 m (1640.50 ft) respectively.

Note about surface temperature:

The surface of the motors can reach temperatures of over 100 °C (212 °F).

Installation altitude above sea level in m (ft)	Coolant temperature (CT) in °C (°F)			
	<30 (86)	30 to 40 (86 to 104)	45 (113)	50 (122)
1000 (3281)	1.07	1.00	0.96	0.92
1500 (4922)	1.04	0.97	0.93	0.89
2000 (6562)	1.00	0.94	0.90	0.86
2500 (8203)	0.96	0.90	0.86	0.83
3000 (9843)	0.92	0.86	0.82	0.79
3500 (11484)	0.88	0.82	0.79	0.75
4000 (13124)	0.82	0.77	0.74	0.71

Duty types S1 and S6 according to EN 5030

S1: Continuous operation duty-type

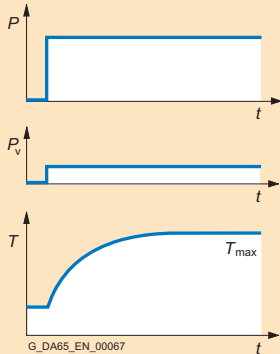

Duty cycle under constant load condition of sufficient duration to establish thermal equilibrium.

Designation: S1

Output specification (torque).

G_DA65_EN_00067

S6: Continuous operation duty-type

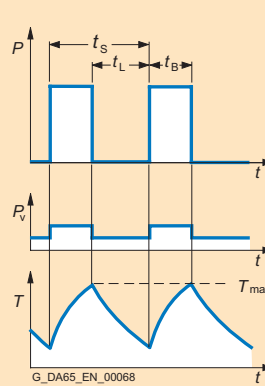

Duty cycle comprising a sequence of identical duty cycles, each of which consists of a period of constant load followed by an interval at no load. There are no de-energized intervals.

Designation:

e.g.: S6 - 40 %, 85 kW. (114 HP).

$$t_r = \frac{t_B}{t_B + t_L}, t_s = 10 \text{ min}$$

G_DA65_EN_00068

Rating plates

SIEMENS			
3 ~ Motor 1FK7060-5AF71-1EH0			
No. YF PN18 4583 01 001			
M ₀ 6,0 Nm	I ₀ 4,5 A	n _N 3000 /min.	
M _n 4,7 Nm	I _n 3,7 A	n _{max.} 6600 /min.	
Th.Cl.F	U _{in} 253 V	IP 64	
Encoder F02 Brake EBD 0,8B / 24 V -- / 15 W			
Rev. No. 000			
		EN60034	
Made in Germany			

D_A65-6038

Example from the 1FK7 series, shaft heights 28 to 100 (adhesive plate)



G_D211_XX_00148

Example from the 1FT6 series (metal plate)

SIEMENS			
3 ~ Motor 1FK7042 - 5AF21 - 1DH3			
No.YF U436 00357 01 001			
M ₀ 3 Nm	I ₀ 3,9 A	n _{max.} 9000 /min	
M _N 2,6 Nm	I _N 3,9 A	n _N 3000 /min	
Encoder I-2048	U _{IN} 147 V	IP 64	
BRAKE 24VDC 13,0W 3001602		RN 000	
		Th.Cl.155 (F) B20	
		EN 60034	
Made in Germany			

G_D211_XX_00150

Example from the 1FK7 series with 300 V DC link voltage (adhesive plate)

SIEMENS			
3 ~ Motor 1FK7040 - 5AK71 - 1KV3 - Z			
No.YF U538 6114 01 001		Z: A13	
M ₁₀ 1,6 Nm	I ₀ 2,25 A	n _{1max} 6000 /min	I _{max.} 7,7 A
M _{1N} 1,0 Nm	I _N 1,5 A	n _{1N} 6000 /min	n ₂ 600 /min
Th.Cl.155 (F)	U _{IN} 258 V	IP 64	M _{2N} 9,70 Nm (S3-60%)
Encoder A - 32	BRAKE 24VDC 13,0W 3001602	RN 000	K02
gear unit type: DYA-090		oil type: Optimol PD1	
ratio: i = 10		quantity of oil: 0,014 m 8 kg	
mounting position: any			
		EN 60034	
Made in Germany			

G_D211_XX_00149

Example from the 1FK7-DYA series (adhesive plate)

AC motors

Overview

Technical definitions

Rating plates

SIEMENS		c		CE	
3 ~ Mot. 1PH7137 - 2NG00 - 0BA0 Nr.YF L994 0025 01 001					
IM B3	IP 55/54	Th.Cl.F			
V	A	kW	cos φ	Hz	1/min
350 Y	60,00	28,00	0,88	68,0	2000 S1
398 Y	56,00	29,00	0,87	77,8	2300 S1
450 Y	52,00	30,00	0,84	89,4	2650 S1
EN 60034					max. 8000 /min
TEMP - SENSOR KTY 84 - 130			ENCODER D01 2048 S/R		
Made in Germany			CODE-NR.: 412		

Example from the 1PH7 series, shaft heights 100 to 160 (adhesive plate)

SIEMENS		c		CE	
3 ~ Mot. 1PL6228-4HF00-0AA0 No N- 1102033010001 / 2000					
IM B3	IP 23	Th.Cl. F		Gew./WT 870 kg	
V	A	kW	cos φ	Hz	1/min
345 Y	476	230	0.86	51	1500
400 Y	473	265	0.86	59	1750
460 Y	452	288	0.85	67	2000
EN60034-1 IEC 34-1			max	4500	1/min
KTY84					
ENCODER H01 1024 S/R					
MADE IN GERMANY					

Example from the 1PL6 series, shaft heights 180 to 280 (metal plate)

Rated torque

The torque supplied on the shaft is indicated in Nm/lb_F-in in the technical selection tables.

$$M_{\text{rated}} = P_{\text{rated}} \times \frac{9550}{n_{\text{rated}}}$$

P_{rated} Rated power in kW/HP

n_{rated} Rated speed in rpm

M_{rated} Rated torque in Nm

$$M_{\text{rated}} = P_{\text{rated}} \times \frac{5250}{n_{\text{rated}}}$$

P_{rated} Rated output in HP

n_{rated} Rated speed in rpm

M_{rated} Rated torque in lbf-ft

DURIGNIT IR 2000 insulation

The DURIGNIT® IR 2000 insulating system consists of high-quality enamel wires and insulating sheeting in conjunction with a solvent-free resin impregnation.

This ensures that these motors will have a high mechanical and electrical strength, high service value and a long service life.

The insulation system protects the winding to a large degree against aggressive gases, vapors, dust, oil and increased air humidity. It can withstand the usual vibration stressing.

The motor insulation is tropicalized, i. e. suitable for air humidity levels of up to 100 %.

All motors have Thermal Class F insulation.

The utilization of these motors corresponds to a Thermal Class F rated power/torque.

Motor protection

The KTY 84-130 temperature sensor is used to measure the motor temperature for converter-fed motor operation.

This sensor is a semi-conductor that changes its resistance depending on temperature in accordance with a defined curve.

Siemens converters determine the motor temperature using the resistance of the temperature sensor.

Their parameters can be set for specific alarm and shutdown temperatures.

The KTY 84-130 temperature sensor is embedded in the winding overhang of the motor like a PTC thermistor.

The sensor is evaluated in the SINAMICS converter as a standard function.

If the motors are operated on converters that do not feature a KTY 84 evaluation circuit, the temperature can be measured with the external 3RS10 temperature monitoring relay. For a detailed description, please refer to Catalog LV 10.

Example units:

- Control supply voltage: 24 V AC/DC
Order No. 3RS1040-1GD50
- Control supply voltage: 24 to 240 V AC/DC
Order No. 3RS1040-1GW50.

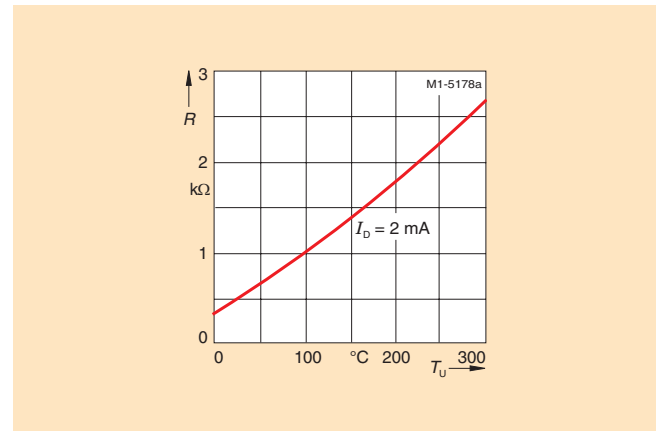

Paint finish

The following finishes are available for the motors:

- Unpainted
(coated with impregnating resin) e.g. 1FK7 or 1PH7
(up to shaft height 160)
- Primed
(for corrosion control) e.g. 1PH7, 1PL6 (shaft height 180 and above)

- Standard finish
(e.g. RAL 7016) e.g. 1PH4, 1PH7, 1PL6, 1FK7, 1FS6, 1FW3
- Special finish
(e.g. RAL 7016) e.g. 1FT6, 1PH7, 1PL6, 1FW3

All motors can be painted over with commercially available paint (up to 2 additional coats).

Type	Suitability of paint finish for climate group in accordance with DIN IEC 60721, Part 2-1	Briefly:	Continuous:
Standard finish	Moderate (expanded) for indoor and outdoor installation with roof protection	Up to 150 °C (302 °F)	Up to 120 °C (248 °F)
Special finish	Worldwide (expanded) for outdoor installation	Briefly: Up to 150 °C (302 °F) Continuous: Up to 120 °C (248 °F)	Also: For corrosive atmospheres up to 1% acid and alkali concentration or permanent dampness in sheltered rooms

Encoder systems

HTL incremental encoder (1024 pulses/revolution or 2048 pulses/revolution)

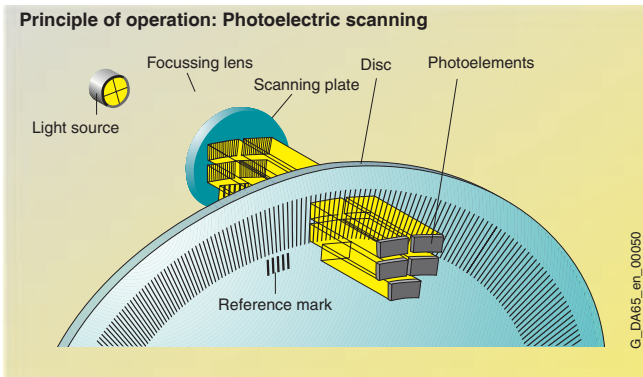

Method of functioning:
photoelectric scanning

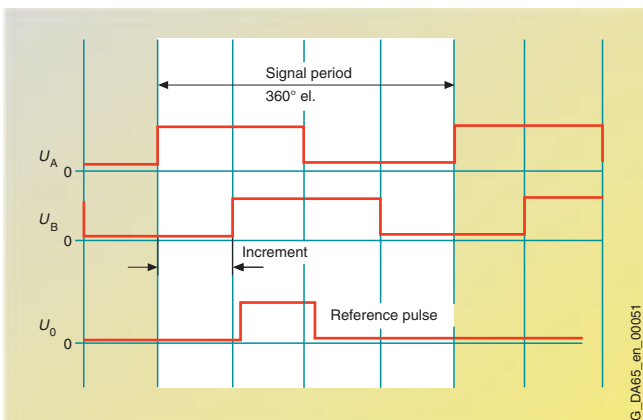

Output signals

Technical data

Supply voltage:	+10 ... 30 V
Output signals:	HTL Track A, track B Zero pulse and inverted signals
PPR count:	1024 (optional: 2048)
Accuracy:	$\pm 1'$
Limit frequency (-3 dB)	160 kHz
Use:	Asynchronous servomotors 1PH7, 1PL6, 1PH4
Max. possible connecting cable length:	
- without transfer of inverted signals	150 m (492 ft)
- with transfer of inverted signals	300 m (984 ft)

2-pole/multi-pole resolver ¹⁾

Principle of operation: Inductive scanning,
sin/cos evaluation for rotor position

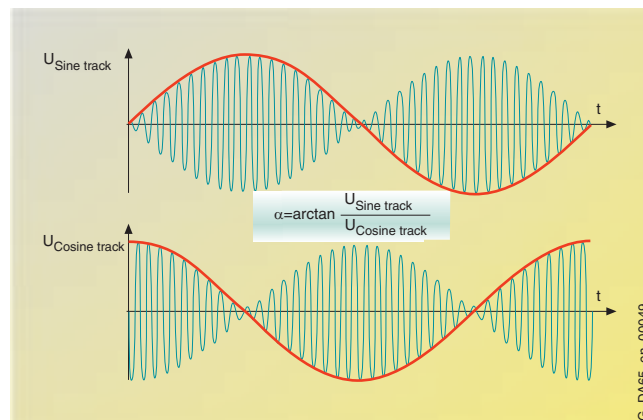
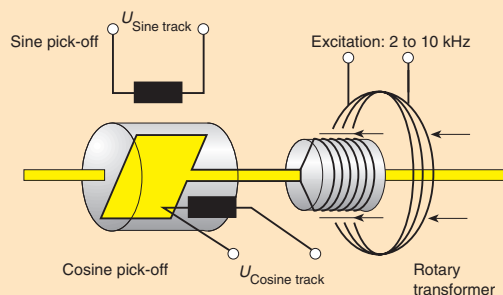

Output signals

Technical data

Operating voltage/frequency	+5 V / 4 kHz
Output signals ²⁾ :	$U_{\text{sine track}} = \hat{u} \times U_{\text{excitation}} \times \sin \alpha$ $U_{\text{cosine track}} = \hat{u} \times U_{\text{excitation}} \times \cos \alpha$
Ratio:	$\hat{u} = 0.5 \pm 5 \%$
Angular error width:	< 5' (multi-pole) < 14' (2-pole) < 20' (2-pole in shaft height 28)
Use:	Synchronous servomotors 1FT6, 1FK7, 1FW3 Asynchronous servomotors 1PH7, 1PH4
Max. possible connecting cable length:	150 m (492 ft) ³⁾

¹⁾ When a multi-pole resolver is used, the number of resolver poles matches the number of motor poles.

²⁾ Output signals:

- 2-pole resolver:
One sine/cos signal per revolution
- 4-pole resolver:
Two sine/cos signals per revolution
- 6-pole resolver:
Three sine/cos signals per revolution

³⁾ With DRIVE-CLiQ interface and MOTION-CONNECT 500:
100 m (328 ft)
with DRIVE-CLiQ interface and MOTION-CONNECT 800:
50 m (164 ft)

Incremental encoder sin/cos 1 V_{pp}

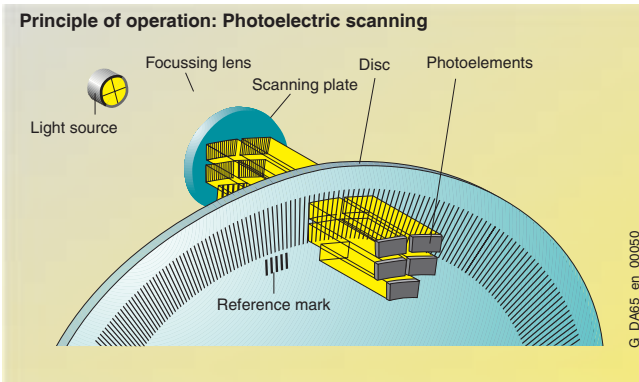

Method of functioning:
photoelectric scanning

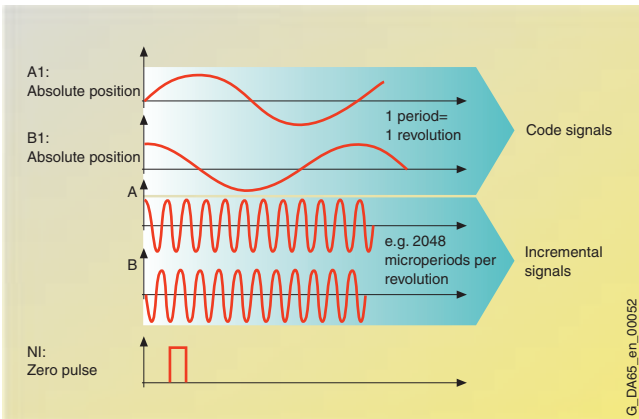

Output signals

Technical data

Supply voltage:	+5 V ± 5 %
Incremental signals (sine-wave):	
• Voltage:	1 V _{pp}
• PPR count:	2048
• Accuracy:	±40°
Code signals:	
• Voltage:	1 V _{pp}
• Signal type (C and D track):	1 sine and 1 cosine signal/revolution
Use:	Synchronous servomotors 1FT6, 1FK7, 1FS6, 1FW3 Asynchronous servomotors 1PH7, 1PL6, 1PH4
Max. possible connecting cable length:	100 m (328 ft) ²⁾

Note about principle of operation diagrams:
These principle of operation diagrams for incremental and absolute encoders have been reprinted with kind permission from the catalog of DR. JOHANNES HEIDENHAIN GmbH, Traunreut, Germany.

¹⁾ Absolute encoder (EnDat) with 2048 pulses/revolution for motors 1FT6, 1FK7, 1FS6 for shaft height 48 and above, 1FW3 and all asynchronous motors.

- Absolute encoder (EnDat) with 512 pulses/revolution for 1FT6 motors for shaft height 28 and 1FK7 for shaft heights 20, 28 and 36.
- Basic absolute encoder (EnDat) with 32 pulses/revolution for 1FK7 motors of shaft height 48 and above.

Absolute encoder (EnDat)

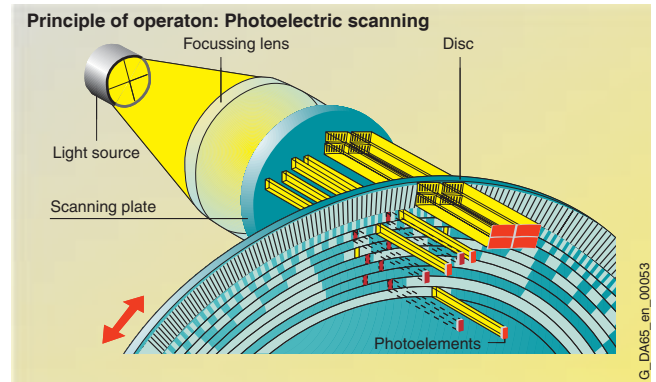

Method of functioning:
photoelectric scanning

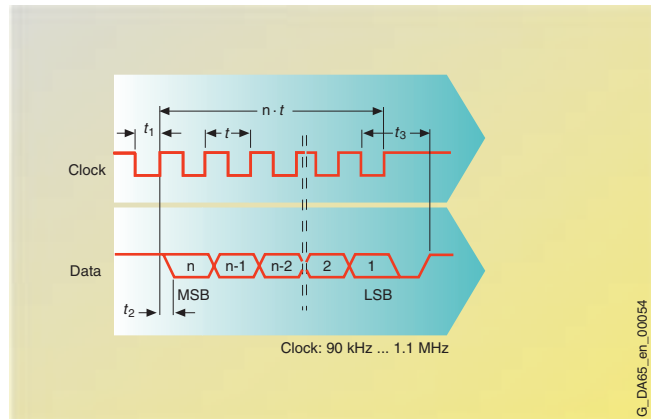

Output signals (serial interface)

Technical data

Supply voltage:	+5 V ± 5 %
Incremental signals (sine-wave):	
• Voltage:	1 V _{pp}
• PPR count:	2048 / 512 / 32
• Accuracy:	±40° / ±80° / ±400° ¹⁾
Code signals:	Synchronous-serial EnDat interface Dual code 4096 encoded revolutions
Use:	Synchronous servomotors 1FT6, 1FK7, 1FS6, 1FW3 Asynchronous servomotors 1PH7, 1PL6, 1PH4
Max. possible connecting cable length:	100 m (328 ft) ²⁾

²⁾ With DRIVE-CLiQ interface and MOTION-CONNECT 500: 100 m (328 ft)
with DRIVE-CLiQ interface and MOTION-CONNECT 800: 50 m (164 ft)

AC motors

Synchronous motors

1FT6 motors

Overview



1FT6 motors are permanent-magnet synchronous motors with compact dimensions.

1FT6 motors with integrated encoders can be operated on the SINAMICS drive system.

The fully digital control system of the SINAMICS S120 drive system and the encoder technology of the 1FT6 motors fulfill the highest demands in terms of dynamic performance, speed setting range, and rotational and positioning accuracy.

1FT6 motors are available as naturally-cooled, forced-ventilated, or water-cooled. With the natural cooling method, heat loss is dissipated through the surface of the motor, whereas with the forced ventilation method, heat is forced out by means of built-on fans. Maximum power ratings, as well as a high degree of protection, can be achieved using water cooling.

Benefits

- Optimum surface quality of the workpiece due to high rotational accuracy (sinusoidal current injection)
- Minimized downtime due to high dynamic performance
- Power and signal connections for use in highly corrosive environments
- High resistance to lateral force
- High thermal reserves for continuous and overload conditions
- High, short-term overload capability (250 ms)
- Extremely high efficiency
- Extremely good drive dynamic response due to the lower rotor moments of inertia
- Low torque ripple 1% (average value)
- High degree of protection

Applications

- High-performance machine tools
- Machines with stringent requirements in terms of dynamic response, precision and flexibility, e.g. packaging machines, high-bay racking vehicles, conveyor systems, handling equipment and printing machines

Technical data

Type of motor	Permanent-magnet synchronous motor
Magnet material	Rare-earth magnet material
Insulation of the stator winding in accordance with EN 60034-1 (IEC 60034-1)	Thermal Class F for a winding temperature of $\Delta T = 100$ K at an ambient temperature of $+40$ °C (104 °F) For water cooling max. inlet temperature $+30$ °C (86 °F)
Type in accordance with EN 60034-7 (IEC 60034-7)	IM B5 (IM V1, IM V3) IM B14 (IM V18, IM V19) IM B35 for 1FT613 and 1FT616
Degree of protection in accordance with EN 60034-5 (IEC 60034-5)	IP64 standard type, IP65 core type
Cooling	Natural cooling, forced ventilation, water cooling
Temperature monitoring	KTY 84 temperature sensor in stator winding
Paint finish	Anthracite RAL 7016
2nd rating plate	Enclosed separately
Shaft end on the drive end in accordance with DIN 748-3 (IEC 60072-1)	Keyless shaft
Radial eccentricity, concentricity and axial eccentricity in accordance with DIN 42955 (IEC 60072-1)	Tolerance N (normal)
Vibration severity in accordance with EN 60034-14 (IEC 60034-14)	Grade N (normal)
Max. sound pressure level in accordance with DIN EN ISO 1680	Naturally-/water-cooled motors 1FT602 ... 1FT604: 55 dB(A) 1FT606 ... 1FT616: 70 dB(A) Forced ventilation motors 1FT608/1FT610: 70 dB(A) 1FT613, 1FT616: 74 dB(A)
Encoder systems, built-in, for motors with/without DRIVE-CLiQ interface	<ul style="list-style-type: none"> • Incremental encoder sin/cos 1 V_{pp} 2048 pulses/revolution • Absolute encoder, multiturn, 2048 pulses/revolution on 1FT603 to 1FT613. 512 pulses/revolution on 1FT602 and traversing range 4096 revolutions with EnDat interface • Multi-pole resolver (number of poles corresponds to number of pole pairs of the motor) • 2-pole resolver
Connection	Connectors for signals and power Terminal box possible on 1FT61
Options	<ul style="list-style-type: none"> • Shaft end on the drive end with featherkey and featherkey way (half-key balancing) • Integrated holding brake • Degree of protection IP67, IP68 M5 sealing air connection present (except with forced ventilation) • Terminal box for power terminal • Planetary gearboxes, built-on (requirement: keyless shaft end, radial eccentricity tolerance N, vibration severity grade N and IP65 degree of protection)

Characteristics

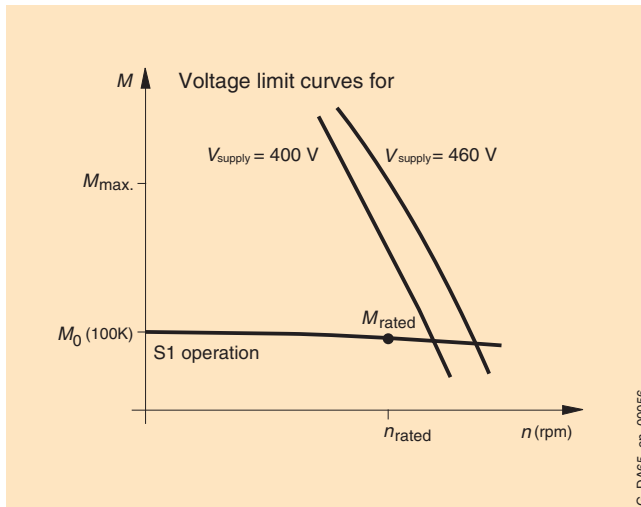

Speed-torque characteristic

G_DA65_en_00056

Further info

Core types can be supplied for certain motor types. For these types express delivery of replacement motors and fast repair service is available in case of emergencies. Therefore, core types should be used for configuration wherever possible.

Options

Order code	Option description	1FT6 Natural cooling	Forced ventilation	Water cooling
K09	Terminal box on right-hand side	–	■ (SH 160)	■ (SH 132 and 160)
K10	Terminal box on left-hand side	–	■ (SH 160)	■ (SH 132 and 160)
L68	Full-key balancing	–	■ (SH 132 and 160)	■ (SH 132 and 160)
M03	Version for Zone 2 hazardous areas (in accordance with IEC EN 60079-15)	■ (up to SH 100)	–	■ (SH 63 to 100)
M39	Version for Zone 22 hazardous areas (in accordance with EN 50281)	■ (up to SH 100)	–	■ (SH 63 to 100)
N05	Non-standard shaft extension (dimensions as for 1FT5)	■ (SH 36 to 100)	–	–
N40	Food industry design	■ (SH 63 to 100)	–	■ (SH 63 to 100)
X01	Jet black finish RAL 9005	■	■	■
X02	Cream finish RAL 9001	■	■	■
X03	Reseda green finish RAL 6011	■	■	■
X04	Pebble gray finish RAL 7032	■	■	■
X05	Sky blue finish RAL 5015	■	■	■
X06	Light ivory finish RAL 1015	■	■	■

■ Option available

– Not available

AC motors

Synchronous motors

1FT6 motors, core type Natural cooling

Selection and ordering data

Rated speed	Shaft height	Rated power	Static torque	Rated torque ¹⁾	Rated current	1FT6 synchronous motors Natural cooling	Number of pole pairs	Rotor moment of inertia (without brake)	Weight (without brake)
n_{rated}	SH	P_{rated} at $\Delta T=100\text{ K}$	M_0 at $\Delta T=100\text{ K}$	M_{rated} at $\Delta T=100\text{ K}$	I_{rated} at $\Delta T=100\text{ K}$	Order No. Core type		J	m
rpm		KW/HP	Nm/lb _f -ft	Nm/lb _f -ft	A			$10^{-4}\text{ kgm}^2/\text{lb}_f\text{-in-s}^2$	kg/lb
2000	100	4.8/6.44	27/19.9	23/17	11	1FT6102-1AC71-■ ■ ■ 1	4	99/0.0876	27.5/60.6
		8.0/10.73	50/36.9	38/28	17.6	1FT6105-1AC71-■ ■ ■ 1	4	168/0.1487	39.5/87.1
3000	48	1.4/1.88	5/3.7	4.3/3.2	2.9	1FT6044-1AF71-■ ■ ■ 1	2	5 1/0.0045	8.3/18.3
	63	1.5/2.01	6/4.4	4.7/3.5	3.4	1FT6062-1AF71-■ ■ ■ 1	3	8.5/0.0752	9.5/20.9
		2.2/2.95	9.5/7	7/5.2	4.9	1FT6064-1AF71-■ ■ ■ 1	3	13/0.0115	12.5/27.6
	80	3.2/4.29	13/9.6	10.3/7.6	8.7	1FT6082-1AF71-■ ■ ■ 1	4	30/0.0266	15/33.1
4500	63	4.6/6.17	20/14.7	14.7/10.8	11	1FT6084-1AF71-■ ■ ■ 1	4	48/0.0425	20.5/45.2
		5.8/7.78	27/19.9	18.5/13.6	13	1FT6086-1AF71-■ ■ ■ 1	4	66.5/0.0589	25.5/56.2
	80	1.7/2.28	6/4.4	3.6/2.7	3.9	1FT6062-1AH71-■ ■ ■ 1	3	8.5/0.0752	9.5/20.9
6000	36	2.3/3.08	9.5/7	4.8/3.5	5.5	1FT6064-1AH71-■ ■ ■ 1	3	13/0.0115	12.5/27.6
		4.9/6.57	20/14.7	10.5/7.7	12.5	1FT6084-1AH71-■ ■ ■ 1	4	48/0.0425	20.5/45.2
	80	5.7/7.64	27/19.9	12/8.8	12.6	1FT6086-1AH71-■ ■ ■ 1	4	66.5/0.0589	25.5/56.2
6000	36	0.88/1.0	2/1.5	1.4/1	2.1	1FT6034-1AK71-■ ■ ■ 1	2	1.1/0.001	4.4/9.7
	80	4.1/5.5	20/14.7	6.5/4.8	9.2	1FT6084-1AK71-■ ■ ■ 1	4	48/0.0425	20.5/45.2

Type:	IM B5	1
Connector outlet direction:	Transverse right (not for 1FT603/1FT604/1FT606) Transverse left (not for 1FT603/1FT604/1FT606) Axial non-drive end (NDE) Axial drive end (DE)	1 2 3 4
Encoder systems for motors without DRIVE-CLiQ interface:	Incremental encoder sin/cos 1 V _{pp} 2048 pulses/revolution Absolute encoder EnDat 2048 pulses/revolution ¹⁾	A E
Encoder systems for motors with DRIVE-CLiQ interface:	Incremental encoder sin/cos 1 V _{pp} 2048 pulses/revolution Absolute encoder EnDat 2048 pulses/revolution ¹⁾	D F
Plain shaft/radial eccentricity tolerance N:	Without holding brake With holding brake	G H

Selection and ordering data

Motor type (continued)	Static current I_0 at M_0 $\Delta T=100$ K A	Calculated power $P_{\text{calc}} = M_0 \times n_{\text{rated}}/9550$ P_{calc} for M_0 $\Delta T=100$ K kW/HP	SINAMICS Motor Module		Power cable with complete shield Motor terminal (and brake terminal) via power connector		
			Rated output current I_{rated} A	Order No. For complete order no., see "SINAMICS S120"	Power con- nector Size	Motor cable cross section ²⁾ mm ²	Order no. Pre-assembled cable
1FT6102-1AC7...	12.1	5.7/7.6	18	6SL312 - TE21-8AA .	1.5	4 x 1.5	6FX 002-5 S21 -....
1FT6105-1AC7...	21.4	10.5/14.8	30	6SL312 - 1TE23-0AA .	1.5	4 x 4	6FX 002-5 S41 -....
1FT6044-1AF7...	3	1.6/2.2	3	6SL312 - TE13-0AA .	1	4 x 1.5	6FX 002-5 S01 -....
1FT6062-1AF7...	4.1	1.9/2.6	5	6SL312 - TE15-0AA .	1	4 x 1.5	6FX 002-5 S01 -....
1FT6064-1AF7...	6.1	3.0/4.0	9	6SL312 - TE21-0AA .	1	4 x 1.5	6FX 002-5 S01 -....
1FT6082-1AF7...	9.6	4.1/5.5	18	6SL312 - TE21-8AA .	1.5	4 x 1.5	6FX 002-5 S21 -....
1FT6084-1AF7...	13.2	6.3/8.5	18	6SL312 - TE21-8AA .	1.5	4 x 1.5	6FX 002-5 S21 -....
1FT6086-1AF7...	16.4	8.5/11.4	18	6SL312 - TE21-8AA .	1.5	4 x 2.5	6FX 002-5 S31 -....
1FT6062-1AH7...	5.7	2.8/3.8	9	6SL312 - TE21-0AA .	1	4 x 1.5	6FX 002-5 S01 -....
1FT6064-1AH7...	9.0	4.5/6.0	9	6SL312 - TE21-0AA .	1	4 x 1.5	6FX 002-5 S01 -....
1FT6084-1AH7...	19.8	9.4/12.6	18	6SL312 - TE21-8AA .	1.5	4 x 4	6FX 002-5 S41 -....
1FT6086-1AH7...	23.3	12.7/17.0	30	6SL312 - 1TE23-0AA .	1.5	4 x 4	6FX 002-5 S41 -....
1FT6034-1AK7...	2.6	1.3/1.7	3	6SL312 - TE13-0AA .	1	4 x 1.5	6FX 002-5 S01 -....
1FT6084-1AK7...	24.1	12.6/16.9	30	6SL312 - 1TE23-0AA .	1.5	4 x 4	6FX 002-5 S41 -....

Cooling:

Internal air cooling
External air cooling

0
1

Motor Module:

Single Motor Module
Double Motor Module

1
2

Power cable model:

MOTION-CONNECT 800
MOTION-CONNECT 500

8
5

Without brake cores
With brake cores

C
D

For length code as well as power and signal cables, see "MOTION-CONNECT cables and connections".

....

¹⁾ If the absolute encoder is used, M_{rated} is reduced by 10%.

²⁾ The current carrying capacity of the power cables corresponds to IEC 60204-1 for type of routing C under continuous operating conditions with an ambient air temperature of +40 °C (104 °F), designed for I_0 (100 K), PVC/PUR-insulated cable.

AC motors

Synchronous motors

1FT6 motors, standard type

Natural cooling

Selection and ordering data

Rated speed	Shaft height	Rated power	Static torque	Rated torque ¹⁾	Rated current	1FT6 synchronous motors Natural cooling	Number of pole pairs	Rotor moment of inertia (without brake)	Weight (without brake)
n_{rated}	SH	P_{rated} at $\Delta T=100\text{ K}$	M_0 at $\Delta T=100\text{ K}$	M_{rated} at $\Delta T=100\text{ K}$	I_{rated} at $\Delta T=100\text{ K}$	Order No. Standard type		J	m
rpm		kW/HP	Nm/lb _f -ft	Nm/lb _f -ft	A			$10^{-4}\text{ kgm}^2/\text{lb}_f\text{-in-s}^2$	kg/lb
1500	100	3.8/5.1	27/19.9	24.5/18.1	8.4	1FT6102-8AB7 ■■■■■	4	99/0.0876	27.5/60.6
		6.4/8.6	50/36.9	41/30.2	14.5	1FT6105-8AB7 ■■■■■	4	168/0.1487	39.5/87.1
		9.6/12.9	70/51.6	61/45	20.5	1FT6108-8AB7 ■■■■■	4	260/0.2301	55.5/122.4
	132	9.7/13.0	75/55.3	62/45.7	19	1FT6132-6AB7 1-■■■■■	3	430/0.3806	85/187.4
		11.8/15.8	95/70	75/55.3	24	1FT6134-6AB7 1-■■■■■	3	547/0.4841	100/220.5
		13.8/18.5	115/84.8	88/64.9	27	1FT6136-6AB7 1-■■■■■	3	664/0.5876	117/258

Type:	IM B5 IM B14 ²⁾ (not for 1FT613)	1 2
Connector outlet direction:	Transverse right Transverse left Axial NDE (not for 1FT613) Axial drive end (DE)	1 2 3 4
Terminal box/ cable entry:	Transverse/from right Transverse/from left axial/from NDE axial/from DE	5 6 7 8
Encoder systems for motors without DRIVE-CLiQ interface:	Incremental encoder sin/cos 1 V_{pp} 2048 pulses/revolution Absolute encoder EnDat 2048 pulses/revolution ¹⁾ Multi-pole resolver 2-pole resolver	A E S T
Encoder systems for motors with DRIVE-CLiQ interface:	Incremental encoder sin/cos 1 V_{pp} 2048 pulses/revolution Absolute encoder EnDat 2048 pulses/revolution ¹⁾ Multi-pole resolver 2-pole resolver	D F U P
Shaft extension:	Radial eccentricity tolerance:	Holding brake:
Fitted key and keyway	N	without
Fitted key and keyway	N	with
Fitted key and keyway	R	without
Fitted key and keyway	R	with
Plain shaft	N	without
Plain shaft	N	with
Plain shaft	R	without
Plain shaft	R	with
Vibration severity grade:	Degree of protection:	A B D E G H K L
N	IP64	0
N	IP65	1
N	IP67	2
N	IP68	6
R	IP64	3
R	IP65	4
R	IP67	5
R	IP68	7

To select the degree of protection and type, see "Selection guide".

Selection and ordering data

Motor type (continued)	Static current I_0 at M_0 $\Delta T=100$ K A	Calculated power $P_{calc} = M_0 \times$ $n_{rated}/9550$ P_{calc} for M_0 $\Delta T=100$ K kW/HP	SINAMICS Motor Module		Power cable with complete shield		
			Rated output current I_{rated} A	Order No. For complete order no., see "SINAMICS S120"	Motor terminal (and brake terminal) via power connector		Order no. Pre-assembled cable
					Power con- nector Size	Motor cable cross section ³⁾ mm ²	
1FT6102-8AB7...	8.7	4.2/5.6	9	6SL312 - TE21-0AA .	1.5	4 x 1.5	6FX 002-5 S21 -....
1FT6105-8AB7...	16.0	7.9/10.6	18	6SL312 - TE21-8AA .	1.5	4 x 2.5	6FX 002-5 S31 -....
1FT6108-8AB7...	22.3	11.0/14.8	30	6SL312 - 1TE23-0AA .	1.5	4 x 4	6FX 002-5 S41 -....
1FT6132-6AB7 ...	21.6	11.8/15.8	30	6SL312 - 1TE23-0AA .	1.5	4 x 4	6FX 002-5 S41 -....
1FT6134-6AB7 ...	27.0	14.9/20.0	30	6SL312 - 1TE23-0AA .	1.5	4 x 4	6FX 002-5 S41 -....
1FT6136-6AB7...	34	18.1/24.3	45	6SL312 - 1TE24-5AA .	1.5	4 x 10	6FX 002-5 S64 -....
Cooling:							
Internal air cooling				0			
External air cooling				1			
Motor Module:							
Single Motor Module				1			
Double Motor Module				2			
Power cable model:							
MOTION-CONNECT 800						8	
MOTION-CONNECT 500						5	
Without brake cores							C
With brake cores							D
For length code as well as power and signal cables, see "MOTION-CONNECT cables and connections".							

1) If the absolute encoder is used, M_{rated} is reduced by 10%.
 2) Same flange as for IM B5 type, but with metric threaded insert in the four mounting holes.
 3) The current carrying capacity of the power cables corresponds to IEC 60204-1 for type of routing C under continuous operation conditions with an ambient air temperature of +40 °C (104 °F), designed for I_0 (100 K), PVC/PUR-insulated cable.

AC motors

Synchronous motors

1FT6 motors, standard type

Natural cooling

Selection and ordering data

Rated speed	Shaft height	Rated power	Static torque	Rated torque ¹⁾	Rated current	1FT6 synchronous motors Natural cooling	Number of pole pairs	Rotor moment of inertia (without brake)	Weight (without brake)
n_{rated}	SH	P_{rated} at $\Delta T=100$ K	M_0 at $\Delta T=100$ K	M_{rated} at $\Delta T=100$ K	I_{rated} at $\Delta T=100$ K	Order No. Standard type		J	m
rpm		kW/HP	Nm/lb _f -ft	Nm/lb _f -ft	A			10 ⁻⁴ kgm ² / lb _f -in ⁻²	kg/lb
2000	63	0.8/1.1	4/2.9	3.7/2.7	1.9	1FT6061-6AC7 ■■■■■■	3	6/0.0053	8/17.6
		1.1/1.5	6/4.4	5.2/3.8	2.6	1FT6062-6AC7 ■■■■■■	3	8.5/0.0075	9.5/20.9
		1.7/2.3	9.5/7	8/5.9	3.8	1FT6064-6AC7 ■■■■■■	3	13/0.0115	12.5/27.6
	80	1.6/2.2	8/5.9	7.5/5.5	4.1	1FT6081-8AC7 ■■■■■■	4	21/0.0186	12.5/27.6
		2.4/3.2	13/9.6	11.4/8.4	6.6	1FT6082-8AC7 ■■■■■■	4	30/0.0266	15/33.1
		3.5/4.7	20/14.7	16.9/12.5	8.3	1FT6084-8AC7 ■■■■■■	4	48/0.0425	20.5/45.2
		4.7/6.3	27/19.9	22.5/16.6	10.9	1FT6086-8AC7 ■■■■■■	4	66.5/0.0589	25.5/56.2
	100	4.8/6.4	27/19.9	23/17	11	1FT6102-8AC7 ■■■■■■	4	99/0.0876	27.5/60.6
		8.0/10.7	50/36.9	38/28	17.6	1FT6105-8AC7 ■■■■■■	4	168/0.1478	39.5/87.1
		11.5/15.4	70/51.6	55/40.5	24.5	1FT6108-8AC7 ■■■■■■	4	260/0.2301	55.5/122.4
	132	11.5/15.4	75/55.3	55/40.5	23	1FT6132-6AC7 1 ■■■■■■	3	430/0.3806	85/187.5
		13.6/18.2	95/70	65/47.9	27	1FT6134-6AC7 1 ■■■■■■	3	547/0.4841	100/220.5
		15.5/20.8	115/84.8	74/54.5	30	1FT6136-6AC7 1 ■■■■■■	3	664/0.5876	117/258

Type:	IM B5 IM B14 ²⁾ (not for 1FT613)	1 2
Connector outlet direction:	Transverse right (not for 1FT606) Transverse left (not for 1FT606) Axial NDE (not for 1FT613) Axial drive end (DE)	1 2 3 4
Terminal box/ cable entry: (only for 1FT61)	Transverse/from right Transverse/from left axial/from NDE axial/from DE	5 6 7 8
Encoder systems for motors without DRIVE-CLiQ interface:	Incremental encoder sin/cos 1 V _{pp} 2048 pulses/revolution Absolute encoder EnDat 2048 pulses/revolution ¹⁾ Multi-pole resolver 2-pole resolver	A E S T
Encoder systems for motors with DRIVE-CLiQ interface:	Incremental encoder sin/cos 1 V _{pp} 2048 pulses/revolution Absolute encoder EnDat 2048 pulses/revolution ¹⁾ Multi-pole resolver 2-pole resolver	D F U P
Shaft extension:	Radial eccentricity tolerance:	Holding brake:
Fitted key and keyway	N	without
Fitted key and keyway	N	with
Fitted key and keyway	R	without
Fitted key and keyway	R	with
Plain shaft	N	without
Plain shaft	N	with
Plain shaft	R	without
Plain shaft	R	with
Vibration severity grade:	Degree of protection:	A B D E G H K L
N	IP64	0
N	IP65	1
N	IP67	2
N	IP68	6
R	IP64	3
R	IP65	4
R	IP67	5
R	IP68	7

To select the degree of protection and type, see "Selection guide".

Selection and ordering data

Motor type (continued)	Static current I_0 at M_0 $\Delta T=100$ K A	Calculated power $P_{calc} = M_0 \times$ $n_{rated}/9550$ P_{calc} for M_0 $\Delta T=100$ K kW/HP	SINAMICS Motor Module		Power cable with complete shield Motor terminal (and brake terminal) via power connector		
			Rated output current I_{rated} A	Order No. For complete order no., see "SINAMICS S120"	Power con- nector Size	Motor cable cross section ³⁾ mm ²	Order no. Pre-assembled cable
1FT6061-6AC7...	1.9	0.84/1.1	3	6SL312 - TE13-0AA.	1	4 x 1.5	6FX 002-5 S01 -....
1FT6062-6AC7...	2.7	1.3/1.7	3	6SL312 - TE13-0AA.	1	4 x 1.5	6FX 002-5 S01 -....
1FT6064-6AC7...	4.2	2.0/2.7	5	6SL312 - TE15-0AA.	1	4 x 1.5	6FX 002-5 S01 -....
1FT6081-8AC7...	3.9	1.7/2.3	5	6SL312 - TE15-0AA.	1.5	4 x 1.5	6FX 002-5 S21 -....
1FT6082-8AC7...	6.6	2.7/3.6	9	6SL312 - TE21-0AA.	1.5	4 x 1.5	6FX 002-5 S21 -....
1FT6084-8AC7...	8.8	4.2/5.6	9	6SL312 - TE21-0AA.	1.5	4 x 1.5	6FX 002-5 S21 -....
1FT6086-8AC7...	11.3	5.7/7.6	18	6SL312 - TE21-8AA.	1.5	4 x 1.5	6FX 002-5 S21 -....
1FT6102-8AC7...	12.1	5.7/7.6	18	6SL312 - TE21-8AA.	1.5	4 x 1.5	6FX 002-5 S21 -....
1FT6105-8AC7...	21.4	10.5/14.8	30	6SL312 - 1 TE23-0AA.	1.5	4 x 4	6FX 002-5 S41 -....
1FT6108-8AC7...	29	14.7/19.7	30	6SL312 - 1 TE23-0AA.	1.5	4 x 6	6FX 002-5 S51 -....
1FT6132-6AC7...	29	15.7/21.1	30	6SL312 - 1 TE23-0AA.	1.5	4 x 6	6FX 002-5 S51 -....
1FT6134-6AC7...	36	19.9/26.7	45	6SL312 - 1 TE24-5AA.	1.5	4 x 10	6FX 002-5 S64 -....
1FT6136-6AC7...	42	24.1/32.3	45	6SL312 - 1 TE24-5AA.	3	4 x 16	6FX 002-5 S23 -....

Cooling:

Internal air cooling
External air cooling

0
1

Motor Module:

Single Motor Module
Double Motor Module

1
2

Power cable model:

MOTION-CONNECT 800
MOTION-CONNECT 500

8
5

Without brake cores
With brake cores

C
D

For length code as well as power and signal cables, see "MOTION-CONNECT cables and connections".

....

- 1) If the absolute encoder is used, M_{rated} is reduced by 10%.
- 2) Same flange as for IM B5 type, but with metric threaded insert in the four mounting holes.
- 3) The current carrying capacity of the power cables corresponds to IEC 60204-1 for type of routing C under continuous operation conditions with an ambient air temperature of +40 °C (104 °F), designed for I_0 (100 K), PVC/PUR-insulated cable.

AC motors

Synchronous motors

1FT6 motors, standard type

Natural cooling

Selection and ordering data

Rated speed	Shaft height	Rated power	Static torque	Rated torque ¹⁾	Rated current	1FT6 synchronous motors Natural cooling	Number of pole pairs	Rotor moment of inertia (without brake)	Weight (without brake)
n_{rated} rpm	SH	P_{rated} at $\Delta T=100$ K kW/HP	M_0 at $\Delta T=100$ K Nm/lb _f -ft	M_{rated} at $\Delta T=100$ K Nm/lb _f -ft	I_{rated} at $\Delta T=100$ K A	Order No. Standard type		J 10 ⁻⁴ kgm ² / lb _f -in-s ²	m kg/lb
3000	48	0.7/0.9	2.6/1.9	2.15/1.6	1.7	1FT6041-4AF71 - ■■■■	2	2.9/0.0025	6.6/14.6
		1.4/1.9	5/3.7	4.3/3.2	2.9	1FT6044-4AF71 - ■■■■	2	5.1/0.0045	8.3/18.3
	63	1.1/1.5	4/2.9	3.5/2.6	2.6	1FT6061-6AF7 ■■■■	3	6/0.0053	8/17.6
		1.5/2.0	6/4.4	4.7/3.5	3.4	1FT6062-6AF7 ■■■■	3	8.5/0.0075	9.5/20.9
		2.2/3.0	9.5/7	7/5.2	4.9	1FT6064-6AF7 ■■■■	3	13/0.0115	12.5/27.6
	80	2.2/3.0	8/5.9	6.9/5.1	5.6	1FT6081-8AF7 ■■■■	4	21/0.0186	12.5/27.6
		3.2/4.3	13/9.6	10.3/7.6	8.7	1FT6082-8AF7 ■■■■	4	30/0.0266	15/33.1
		4.6/6.2	20/14.7	14.7/10.8	11	1FT6084-8AF7 ■■■■	4	48/0.0425	20.5/45.2
		5.8/7.8	27/19.9	18.5/13.6	13	1FT6086-8AF7 ■■■■	4	66.5/0.0589	25.5/56.2
	100	6.1/8.2	27/19.9	19.5/14.4	13.2	1FT6102-8AF7 ■■■■	4	99/0.0876	27.5/60.6
		9.7/13.0	50/36.9	31/22.8	22.5	1FT6105-8AF7 ■■■■	4	168/0.1487	39.5/87.1
		11.6/15.6	70/51.6	37/27.3	25	1FT6108-8AF7 ■■■■	4	260/0.2301	55.5/122.4
132	11.3/15.2	75/55.3	36/26.5	23	1FT6132-6AF71 - ■■■■	3	430/0.3806	85/187.4	

Type:	IM B5 IM B14 ²⁾ (not for 1FT604/1FT613)	1 2
Connector outlet direction:	Transverse right (not for 1FT604/1FT606) Transverse left (not for 1FT604/1FT606) Axial NDE (not for 1FT613) Axial drive end (DE)	1 2 3 4
Terminal box/ cable entry: (only for 1FT61)	Transverse/from right Transverse/from left axial/from NDE axial/from DE	5 6 7 8
Encoder systems for motors without DRIVE-CLiQ interface:	Incremental encoder sin/cos 1 V _{pp} 2048 pulses/revolution Absolute encoder EnDat 2048 pulses/revolution ¹⁾ Multi-pole resolver 2-pole resolver	A E S T
Encoder systems for motors with DRIVE-CLiQ interface:	Incremental encoder sin/cos 1 V _{pp} 2048 pulses/revolution Absolute encoder EnDat 2048 pulses/revolution ¹⁾ Multi-pole resolver 2-pole resolver	D F U P
Shaft extension:	Radial eccentricity tolerance:	Holding brake:
Fitted key and keyway	N	without
Fitted key and keyway	N	with
Fitted key and keyway	R	without
Fitted key and keyway	R	with
Plain shaft	N	without
Plain shaft	N	with
Plain shaft	R	without
Plain shaft	R	with
Vibration severity grade:	Degree of protection:	A B D E G H K L
N	IP64	0
N	IP65	1
N	IP67	2
N	IP68	6
R	IP64	3
R	IP65	4
R	IP67	5
R	IP68	7

To select the degree of protection and type, see "Selection guide".

Selection and ordering data

Motor type (continued)	Static current I_0 at M_0 $\Delta T=100$ K A	Calculated power $P_{\text{calc}} = M_0 \times n_{\text{rated}}/9550$ P_{calc} for M_0 $\Delta T=100$ K kW/HP	SINAMICS Motor Module		Power cable with complete shield Motor terminal (and brake terminal) via power connector		
			Rated output current I_{rated} A	Order No. For complete order no., see "SINAMICS S120"	Power con- nector Size	Motor cable cross section ⁴⁾ mm ²	Order no. Pre-assembled cable
1FT6041-4AF7 ...	1.9	0.8/1.1	3	6SL312 - TE13-0AA.	1	4 x 1.5	6FX 002-5 S01 -....
1FT6044-4AF7 ...	3	1.6/2.2	3	6SL312 - TE13-0AA.	1	4 x 1.5	6FX 002-5 S01 -....
1FT6061-6AF7 ...	2.7	1.3/1.7	3	6SL312 - TE13-0AA.	1	4 x 1.5	6FX 002-5 S01 -....
1FT6062-6AF7 ...	4.1	1.9/2.6	5	6SL312 - TE15-0AA.	1	4 x 1.5	6FX 002-5 S01 -....
1FT6064-6AF7 ...	6.1	3.0/4.0	9	6SL312 - TE21-0AA.	1	4 x 1.5	6FX 002-5 S01 -....
1FT6081-8AF7 ...	5.8	2.5/3.4	9	6SL312 - TE21-0AA.	1.5	4 x 1.5	6FX 002-5 S21 -....
1FT6082-8AF7 ...	9.6	4.1/5.5	18	6SL312 - TE21-8AA.	1.5	4 x 1.5	6FX 002-5 S21 -....
1FT6084-8AF7 ...	13.2	6.3/8.5	18	6SL312 - TE21-8AA.	1.5	4 x 1.5	6FX 002-5 S21 -....
1FT6086-8AF7 ...	16.4	8.5/11.4	18	6SL312 - TE21-8AA.	1.5	4 x 2.5	6FX 002-5 S31 -....
1FT6102-8AF7 ...	16.9	8.5/11.4	18	6SL312 - TE21-8AA.	1.5	4 x 2.5	6FX 002-5 S31 -....
1FT6105-8AF7 ...	32	15.7/21.1	30 ³⁾	6SL312 - 1 TE23-0AA.	1.5	4 x 6	6FX 002-5 S51 -....
1FT6108-8AF7 ...	41	22.0/29.5	45	6SL312 - 1 TE24-5AA.	3	4 x 16	6FX 002-5 S23 -....
1FT6132-6AF7 ...	43	23.6/31.7	45	6SL312 - 1 TE24-5AA.	3	4 x 16	6FX 002-5 S23 -....
Cooling:							
Internal air cooling							
External air cooling							
Motor Module:							
Single Motor Module							
Double Motor Module							
Power cable model:							
MOTION-CONNECT 800							
MOTION-CONNECT 500							
Without brake cores							
With brake cores							
For length code as well as power and signal cables, see "MOTION-CONNECT cables and connections".							

- 1) If the absolute encoder is used, M_{rated} is reduced by 10%.
- 2) Same flange as for IM B5 type, but with metric threaded insert in the four mounting holes.
- 3) With the specified Motor Module, the motor cannot be fully utilized with M_0 at $\Delta T = 100$ K winding temperature rise. If a Motor Module with a higher rating is used, you must check whether the specified power cable can be connected to it.

- 4) The current carrying capacity of the power cables corresponds to IEC 60204-1 for type of routing C under continuous operation conditions with an ambient air temperature of +40 °C (104 °F), designed for I_0 (100 K), PVC/PUR-insulated cable.

AC motors

Synchronous motors

1FT6 motors, standard type

Natural cooling

Selection and ordering data

Rated speed	Shaft height	Rated power	Static torque	Rated torque ¹⁾	Rated current	1FT6 synchronous motors Natural cooling	Number of pole pairs	Rotor moment of inertia (without brake)	Weight (without brake)	
n_{rated}	SH	P_{rated} at $\Delta T=100\text{ K}$	M_0 at $\Delta T=100\text{ K}$	M_{rated} at $\Delta T=100\text{ K}$	I_{rated} at $\Delta T=100\text{ K}$	Order No. Standard type		J	m	
rpm		kW/HP	Nm/lb _f -ft	Nm/lb _f -ft	A			10 ⁻⁴ kgm ² / lb _f -in ⁻²	kg/lb	
4500	63	1.4/1.9	4/2.9	2.9/2.1	3.4	1FT6061-6AH7 ■■■■	3	6/0.0053	8/17.6	
		1.7/2.3	6/4.4	3.6/2.7	3.9	1FT6062-6AH7 ■■■■	3	8.5/0.0075	9.5/20.9	
		2.3/3.1	9.5/7	4.8/3.5	5.5	1FT6064-6AH7 ■■■■	3	13/0.0115	12.5/27.6	
	80	2.7/3.6	8/5.9	5.8/4.3	7.3	1FT6081-8AH7 ■■■■	4	21/0.0186	12.5/27.6	
		4/5.4	13/9.6	8.5/6.3	11	1FT6082-8AH7 ■■■■	4	30/0.0266	15/33.1	
		4.9/6.6	20/14.7	10.5/7.7	12.5	1FT6084-8AH7 ■■■■	4	48/0.0425	20.5/45.2	
		5.7/7.6	27/19.9	12/8.8	12.6	1FT6086-8AH7 ■■■■	4	66.5/0.0589	25.5/56.2	
	100	5.7/7.6	27/19.9	12/8.8	12	1FT6102-8AH7 ■■■■	4	99/0.0876	27.5/60.6	
	Type:		IM B5 IM B14 ²⁾			1 2				
	Connector outlet direction:		Transverse right (not for 1FT606) Transverse left (not for 1FT606) Axial NDE Axial DE			1 2 3 4				
	Terminal box/ cable entry: (only for 1FT61)		Transverse/from right Transverse/from left axial/from NDE axial/from DE			5 6 7 8				
	Encoder systems for motors without DRIVE-CLiQ interface:		Incremental encoder sin/cos 1 V _{pp} 2048 pulses/revolution Absolute encoder EnDat 2048 pulses/revolution ¹⁾ Multi-pole resolver 2-pole resolver			A E S T				
Encoder systems for motors with DRIVE-CLiQ interface:		Incremental encoder sin/cos 1 V _{pp} 2048 pulses/revolution Absolute encoder EnDat 2048 pulses/revolution ¹⁾ Multi-pole resolver 2-pole resolver			D F U P					
Shaft extension:		Radial eccentricity tolerance:		Holding brake:						
Fitted key and keyway		N		without						
Fitted key and keyway		N		with						
Fitted key and keyway		R		without						
Fitted key and keyway		R		with						
Plain shaft		N		without						
Plain shaft		N		with						
Plain shaft		R		without						
Plain shaft		R		with						
Vibration severity grade:		Degree of protection:								
N		IP64							0	
N		IP65							1	
N		IP67							2	
N		IP68							6	
R		IP64							3	
R		IP65							4	
R		IP67							5	
R		IP68							7	

To select the degree of protection and type, see "Selection guide".

Selection and ordering data

Motor type (continued)	Static current I_0 at M_0 $\Delta T=100$ K A	Calculated power $P_{\text{calc}} = M_0 \times$ $n_{\text{rated}}/9550$ P_{calc} for M_0 $\Delta T=100$ K kW/HP	SINAMICS Motor Module		Power cable with complete shield Motor terminal (and brake terminal) via power connector		
			Rated output current I_{rated} A	Order No. For complete order no., see "SINAMICS S120"	Power con- nector Size	Motor cable cross section ⁴⁾ mm ²	Order no. Pre-assembled cable
1FT6061-6AH7...	4	1.9/2.6	5	6SL312 - TE15-0AA.	1	4 x 1.5	6FX 002-5 S01 -....
1FT6062-6AH7...	5.7	2.8/3.8	9	6SL312 - TE21-0AA.	1	4 x 1.5	6FX 002-5 S01 -....
1FT6064-6AH7...	9.0	4.5/6.0	9	6SL312 - TE21-0AA.	1	4 x 1.5	6FX 002-5 S01 -....
1FT6081-8AH7...	8.6	3.8/5.1	9	6SL312 - TE21-0AA.	1.5	4 x 1.5	6FX 002-5 S21 -....
1FT6082-8AH7...	14.8	6.1/8.2	18	6SL312 - TE21-8AA.	1.5	4 x 1.5	6FX 002-5 S21 -....
1FT6084-8AH7...	19.8	9.4/12.6	18 ³⁾	6SL312 - TE21-8AA.	1.5	4 x 4	6FX 002-5 S41 -....
1FT6086-8AH7...	23.3	12.7/17.0	30	6SL312 - 1TE23-0AA.	1.5	4 x 4	6FX 002-5 S41 -....
1FT6102-8AH7...	24.1	12.7/17.0	30	6SL312 - 1TE23-0AA.	1.5	4 x 4	6FX 002-5 S41 -....
Cooling:							
Internal air cooling							
External air cooling							
Motor Module:							
Single Motor Module							
Double Motor Module							
Power cable model:							
MOTION-CONNECT 800							
MOTION-CONNECT 500							
Without brake cores							
With brake cores							
For length code as well as power and signal cables, see "MOTION-CONNECT cables and connections".							

1) If the absolute encoder is used, M_{rated} is reduced by 10%.
 2) Same flange as for IM B5 type, but with metric threaded insert in the four mounting holes.
 3) With the specified Motor Module, the motor cannot be fully utilized with M_0 at $\Delta T = 100$ K winding temperature rise.

4) The current carrying capacity of the power cables corresponds to IEC 60204-1 for type of routing C under continuous operation conditions with an ambient air temperature of +40 °C (104 °F), designed for I_0 (100 K), PVC/PUR-insulated cable.

AC motors

Synchronous motors

1FT6 motors, standard type

Natural cooling

Selection and ordering data

Rated speed	Shaft height	Rated power	Static torque	Rated torque ¹⁾	Rated current	1FT6 synchronous motors Natural cooling	Number of pole pairs	Rotor moment of inertia (without brake)	Weight (without brake)
n_{rated}	SH	P_{rated} at $\Delta T=100$ K	M_0 at $\Delta T=100$ K	M_{rated} at $\Delta T=100$ K	I_{rated} at $\Delta T=100$ K	Order No. Standard type		J	m
rpm		kW/HP	Nm/lb _f -ft	Nm/lb _f -ft	A			10^{-4} kgm ² / lb _f -in ²	kg/lb
6000	28	0.19/0.3	0.4/0.3	0.3/0.2	1.1	1FT6021-6AK71 - ■■■■	3	0.21/0.0002	1.2/2.6
		0.31/0.4	0.8/0.6	0.5/0.4	0.9	1FT6024-6AK71 - ■■■■	3	0.34/0.0003	2.1/4.6
	36	0.47/0.6	1/0.7	0.75/0.6	1.2	1FT6031-4AK71 - ■■■■	2	0.65/0.0006	3.1/6.8
		0.88/1.2	2/1.5	1.4/1	2.1	1FT6034-4AK71 - ■■■■	2	1.1/0.0010	4.4/9.7
	48	1.1/1.5	2.6/1.9	1.7/1.3	2.4	1FT6041-4AK71 - ■■■■	2	2.9/0.0025	6.6/14.6
		1.9/2.6	5/3.7	3/2.2	4.1	1FT6044-4AK71 - ■■■■	2	5.1/0.0045	8.3/18.3
	63	1.3/1.7	4/2.9	2.1/1.5	3.1	1FT6061-6AK71 - ■■■■	3	6/0.0053	8/17.6
		1.3/1.7	6/4.4	2.1/1.5	3.2	1FT6062-6AK71 - ■■■■	3	8.5/0.0075	9.5/20.9
		1.3/1.7	9.5/7	2.1/1.5	3.5	1FT6064-6AK71 - ■■■■	3	13/0.0115	12.5/27.6
	80	2.9/4	8/5.9	4.6/3.4	7.7	1FT6081-8AK71 - ■■■■	4	21/0.0186	12.5/27.6
3.5/4.7		13/9.6	5.5/4.1	9.1	1FT6082-8AK71 - ■■■■	4	30/0.0266	15/33.1	
4.1/5.5		20/14.7	6.5/4.8	9.2	1FT6084-8AK71 - ■■■■	4	48/0.0425	20.5/45.2	

Type:	IM B5 IM B14 ²⁾ (not for 1FT602/1FT603/1FT604)	1 2
Connector outlet direction:	Transverse right (not for 1FT603/1FT604/1FT606) Transverse left (not for 1FT603/1FT604/1FT606) Axial NDE Axial DE	1 2 3 4
Encoder systems for motors without DRIVE-CLiQ interface:	Incremental encoder sin/cos 1 V _{pp} 2048 pulses/revolution Absolute encoder EnDat 2048 pulses/revolution ¹⁾ (not for 1FT602) Absolute encoder EnDat 512 pulses/revolution ¹⁾ (only for 1FT602) Multi-pole resolver 2-pole resolver	A E H S T
Encoder systems for motors with DRIVE-CLiQ interface:	Incremental encoder sin/cos 1 V _{pp} 2048 pulses/revolution Absolute encoder EnDat 2048 pulses/revolution ¹⁾ (not for 1FT602) Absolute encoder EnDat 512 pulses/revolution ¹⁾ (only for 1FT602) Multi-pole resolver 2-pole resolver	D F L U P
Shaft extension:	Radial eccentricity tolerance:	Holding brake:
Fitted key and keyway	N	without
Fitted key and keyway	N	with
Fitted key and keyway	R	without
Fitted key and keyway	R	with
Plain shaft	N	without
Plain shaft	N	with
Plain shaft	R	without
Plain shaft	R	with
Vibration severity grade:	Degree of protection:	A B D E G H K L
N	IP64	0
N	IP65 (not for 1FT602)	1
N	IP67	2
N	IP68 (not for 1FT602)	6
R	IP64	3
R	IP65 (not for 1FT602)	4
R	IP67	5
R	IP68 (not for 1FT602)	7

To select the degree of protection and type, see "Selection guide".

Selection and ordering data

Motor type (continued)	Static current I_0 at M_0 $\Delta T=100$ K A	Calculated power $P_{\text{calc}} = M_0 \times n_{\text{rated}}/9550$ P_{calc} for M_0 $\Delta T=100$ K kW/HP	SINAMICS Motor Module		Power cable with complete shield Motor terminal (and brake terminal) via power connector		
			Rated output current I_{rated} A	Order No. For complete order no., see "SINAMICS S120"	Power con- nector Size	Motor cable cross section ³⁾ mm ²	Order no. Pre-assembled cable
1FT6021-6AK7 ...	1.25	0.3/0.4	3	6SL312 - TE13-0AA.	1	4 x 1.5	6FX 002-5 S01 -....
1FT6024-6AK7...	1.25	0.5/0.7	3	6SL312 - TE13-0AA.	1	4 x 1.5	6FX 002-5 S01 -....
1FT6031-4AK7 ...	1.4	0.6/0.8	3	6SL312 - TE13-0AA.	1	4 x 1.5	6FX 002-5 S01 -....
1FT6034-4AK7...	2.6	1.3/1.7	3	6SL312 - TE13-0AA.	1	4 x 1.5	6FX 002-5 S01 -....
1FT6041-4AK7 ...	3	1.6/2.2	3	6SL312 - TE13-0AA.	1	4 x 1.5	6FX 002-5 S01 -....
1FT6044-4AK7 ...	5.9	3.1/4.2	9	6SL312 - TE21-0AA.	1	4 x 1.5	6FX 002-5 S01 -....
1FT6061-6AK7...	5	2.5/3.4	5	6SL312 - TE15-0AA.	1	4 x 1.5	6FX 002-5 S01 -....
1FT6062-6AK7...	7.6	3.8/5.1	9	6SL312 - TE21-0AA.	1	4 x 1.5	6FX 002-5 S01 -....
1FT6064-6AK7...	12	4.0/5.4	18	6SL312 - TE21-8AA.	1	4 x 1.5	6FX 002-5 S01 -....
1FT6081-8AK7...	11.1	5.0/6.7	18	6SL312 - TE21-8AA.	1.5	4 x 1.5	6FX 002-5 S21 -....
1FT6082-8AK7...	17.3	8.2/11	18	6SL312 - TE21-8AA.	1.5	4 x 2.5	6FX 002-5 S31 -....
1FT6084-8AK7...	24.1	12.6/16.9	30	6SL312 - 1TE23-0AA.	1.5	4 x 4	6FX 002-5 S41 -....

Cooling:

Internal air cooling
External air cooling

0
1

Motor Module:

Single Motor Module
Double Motor Module

1
2

Power cable model:

MOTION-CONNECT 800
MOTION-CONNECT 500

8
5

Without brake cores
With brake cores

C
D

For length code as well as power and signal cables, see "MOTION-CONNECT cables and connections".

....

- 1) If the absolute encoder is used, M_{rated} is reduced by 10%.
- 2) Same flange as for IM B5 type, but with metric threaded insert in the four mounting holes.
- 3) The current carrying capacity of the power cables corresponds to IEC 60204-1 for type of routing C under continuous operation conditions with an ambient air temperature of +40 °C (104 °F), designed for I_0 (100 K), PVC/PUR-insulated cable.

AC motors

Synchronous motors

1FT6 motors, standard type

Forced ventilation

Selection and ordering data

Rated speed	Shaft height	Rated power	Static torque	Rated torque ¹⁾	Rated current	1FT6 synchronous motors Forced ventilation ²⁾	Number of pole pairs	Rotor moment of inertia (without brake)	Weight (without brake)	
n_{rated}	SH	P_{rated} at $\Delta T=100$ K	M_0 at $\Delta T=100$ K	M_{rated} at $\Delta T=100$ K	I_{rated} at $\Delta T=100$ K	Order No. Standard type		J	m	
rpm		kW/HP	Nm/lb _f -ft	Nm/lb _f -ft	A			10 ⁻⁴ kgm ² / lb _f -in ²	kg/lb	
1500	100	9.3/12.5	65/47.9	59/43.5	21.7	1FT6105-8SB7 - ■■■■	4	168/0.1487	45.5/100.3	
		13/17.4	90/66.3	83/61.2	31	1FT6108-8SB7 - ■■■■	4	260/0.2301	61.5/135.6	
	132	16/21.5	110/81.1	102/75.5	36	1FT6132-6SB71 - ■■■■	3	430/0.3806	91/200.6	
		20.4/27.4	140/103.2	130/95.8	45	1FT6134-6SB71 - ■■■■	3	547/0.4810	106/233.7	
		25.1/33.7	175/129	160/117.9	55	1FT6136-6SB71 - ■■■■	3	664/0.5876	123/271.2	
2000	100	11.7/15.7	65/47.9	56/41.3	28	1FT6105-8SC7 - ■■■■	4	168/0.1487	45.5/100.3	
		16.8/22.5	90/66.3	80/59	40	1FT6108-8SC7 - ■■■■	4	260/0.2301	61.5/135.6	
	132	20.5/27.5	110/81.1	98/72.2	46	1FT6132-6SC71 - ■■■■	3	430/0.3806	91/200.6	
		26.2/35.1	140/103.2	125/92.1	57	1FT6134-6SC71 - ■■■■	3	547/0.4810	106/233.7	
			32.5/43.6	175/129	155/114.2	72	1FT6136-6SC71 - ■■■■	3	664/0.5876	123/271.2
	Type:		IM B5 IM B14 ³⁾ (not for 1FT613.)				1 2			
Connector outlet direction:		Transverse right Transverse left Axial NDE (not for 1FT613.) Axial drive end (DE)				1 2 3 4				
Terminal box/ cable entry:		Transverse/from right Transverse/from left axial/from NDE axial/from DE				5 6 7 8				
Encoder systems for motors without DRIVE-CLiQ interface:		Incremental encoder sin/cos 1 V _{pp} 2048 pulses/revolution Absolute encoder EnDat 2048 pulses/revolution ¹⁾ Multi-pole resolver 2-pole resolver				A E S T				
Encoder systems for motors with DRIVE-CLiQ interface:		Incremental encoder sin/cos 1 V _{pp} 2048 pulses/revolution Absolute encoder EnDat 2048 pulses/revolution ¹⁾ Multi-pole resolver 2-pole resolver				D F U P				
Shaft extension:		Radial eccentricity tolerance:		Holding brake:						
Fitted key and keyway		N		without						
Fitted key and keyway		N		with						
Fitted key and keyway		R		without						
Fitted key and keyway		R		with						
Plain shaft		N		without						
Plain shaft		N		with						
Plain shaft		R		without						
Plain shaft		R		with						
Vibration severity grade:		Degree of protection: ⁴⁾								
N		IP64								
N		IP65								
R		IP64								
R		IP65								

To select the degree of protection and type, see "Selection guide".

Selection and ordering data

Motor type (continued)	Static current I_0 at M_0 $\Delta T=100$ K A	Calculated power $P_{\text{calc}} = M_0 \times \frac{n_{\text{rated}}}{9550}$ P_{calc} for M_0 $\Delta T=100$ K kW/HP	SINAMICS Motor Module		Power cable with complete shield Motor terminal (and brake terminal) via power connector		
			Rated output current I_{rated} A	Order No. For complete order no., see "SINAMICS S120"	Power connector Size	Motor cable cross section ⁵⁾ mm ²	Order no. Pre-assembled cable
1FT6105-8SB7...	21.9	10.2/13.7	30	6SL312 -1TE23-0AA.	1.5	4 x 4	6FX002-5S41-....
1FT6108-8SB7...	30	14.1/18.9	30	6SL312 -1TE23-0AA.	1.5	4 x 6	6FX002-5S51-....
1FT6132-6SB7...	36	17.3/23.2	45	6SL312 -1TE24-5AA.	3	4 x 16	6FX002-5S23-....
1FT6134-6SB7...	44	22.0/29.5	60	6SL312 -1TE26-0AA.	3	4 x 16	6FX002-5S23-....
1FT6136-6SB7...	55	27.5/36.9	60	6SL312 -1TE26-0AA.	3	4 x 16	6FX002-5S23-....
1FT6105-8SC7...	30	13.6/18.2	30	6SL312 -1TE23-0AA.	1.5	4 x 6	6FX002-5S51-....
1FT6108-8SC7...	41	18.8/25.2	45	6SL312 -1TE24-5AA.	3	4 x 16	6FX002-5S23-....
1FT6132-6SC7...	47	23.0/30.8	60	6SL312 -1TE26-0AA.	3	4 x 16	6FX002-5S23-....
1FT6134-6SC7...	58	29.3/39.3	60	6SL312 -1TE26-0AA.	3	4 x 16	6FX002-5S23-....
1FT6136-6SC7...	77	36.6/49.1	85	6SL312 -1TE28-5AA.	3	4 x 25	6FX002-5DS33-....

Cooling:

Internal air cooling
External air cooling

0
1

Motor Module:

Single Motor Module

1

Power cable model:

MOTION-CONNECT 800
MOTION-CONNECT 500

8
5

Without brake cores
With brake cores

C
D

For length code as well as power and signal cables, see "MOTION-CONNECT cables and connections".

Notes on forced ventilation

	Shaft heights 80 and 100	Shaft height 132
Direction of air flow	From NDE to DE	From DE to NDE
Connection system	Connector size 1	Terminal box
Type of connecting cable	6FX.002-5CA01-....	6FX.008-1BB11-
Pin and terminal assignments	Pin 1: L1, Pin 2: N	U1/L1: V2/L2: W3/L3
Supply voltage	220/260 V 1 AC, 50/60 Hz	400/460 V 3 AC, 50/60 Hz
Max. fan current	0.3 A	0.4 A
Weight of the fan module, approx.	4.8 kg (10.6 lb)	5.6 kg (12.3 lb)
Sound pressure level	70 dB (A)	74 dB (A)

- 1) If the absolute encoder is used, M_{rated} is reduced by 10%.
- 2) Not for use in environments containing electrically conductive dust. Forced ventilation cannot be used in the presence of flammable, corrosive, electrically conductive or explosive dust.
- 3) Same flange as for IM B5 type, but with metric threaded insert in the four mounting holes.

- 4) The degree of protection refers to the motor. The built-on fan meets the requirements of degree of protection IP54.
- 5) The current carrying capacity of the power cables corresponds to IEC 60204-1 for type of routing C under continuous operation conditions with an ambient air temperature of +40 °C (104 °F), designed for I_0 (100 K), PVC/PUR-insulated cable.

AC motors

Synchronous motors

1FT6 motors, standard type

Forced ventilation

Selection and ordering data

Rated speed	Shaft height	Rated power	Static torque	Rated torque ¹⁾	Rated current	1FT6 synchronous motors Forced ventilation ²⁾	Number of pole pairs	Rotor moment of inertia (without brake)	Weight (without brake)
n_{rated}	SH	P_{rated} at $\Delta T=100$ K	M_0 at $\Delta T=100$ K	M_{rated} at $\Delta T=100$ K	I_{rated} at $\Delta T=100$ K	Order No. Standard type		J	m
rpm		kW/HP	Nm/lb _f -ft	Nm/lb _f -ft	A			10^{-4} kgm ² / lb _f -in-s ²	kg/lb
3000	80	6.9/9.3	26/19.2	22/16.2	17	1FT6084-8SF7 ■ - ■ ■ ■ ■	4	48/0.0425	25/55.1
		9.7/13.0	35/25.8	31/22.8	24.5	1FT6086-8SF7 ■ - ■ ■ ■ ■	4	66.5/0.0589	30/66.2
	100	15.7/21.1	65/47.9	50/36.9	35	1FT6105-8SF7 ■ - ■ ■ ■ ■	4	168/0.1487	45.5/100.3
4500	132	22/29.5	90/66.3	70/51.6	53	1FT6108-8SF7 ■ - ■ ■ ■ ■	4	260/0.2301	61.5/135.6
		28.3/38.0	110/81.1	90/66.3	62	1FT6132-6SF71 ■ - ■ ■ ■ ■	3	430/0.3806	91/200.6
		34.6/46.4	140/103.2	110/81.1	72	1FT6134-6SF71 ■ - ■ ■ ■ ■	3	547/0.4810	106/233.7
6000	104	45.5/61.0	175/129	145/106.9	104	1FT6136-6SF71 ■ - ■ ■ ■ ■	3	664/0.5878	123/271.2
		9.4/12.6	26/19.2	20/14.7	24.5	1FT6084-8SH7 ■ - ■ ■ ■ ■	4	48/0.0425	25/55.1
		12.7/17.0	35/25.8	27/19.9	31.5	1FT6086-8SH7 ■ - ■ ■ ■ ■	4	66.5/0.0589	30/66.2
4500	100	18.8/25.2	65/47.9	40/29.9	41	1FT6105-8SH7 ■ - ■ ■ ■ ■	4	168/0.1487	45.5/100.3
		10.7/14.4	26/19.2	17/12.5	25.5	1FT6084-8SK7 ■ - ■ ■ ■ ■	4	48/0.0425	25/55.1
6000	80	13.8/18.5	35/25.8	22/16.2	29	1FT6086-8SK7 ■ - ■ ■ ■ ■	4	66.5/0.0589	30/66.2

Type:	IM B5 IM B14 ³⁾ (not for 1FT613.)	1 2
Connector outlet direction (not for 1FT6136-6SF71):	Transverse right Transverse left Axial NDE (not for 1FT613.) Axial drive end (DE)	1 2 3 4
Terminal box/ cable entry: (only for 1FT61)	Transverse/from right Transverse/from left axial/from NDE axial/from DE	5 6 7 8
Encoder systems for motors without DRIVE-CLiQ interface:	Incremental encoder sin/cos 1 V _{pp} 2048 pulses/revolution Absolute encoder EnDat 2048 pulses/revolution ¹⁾ Multi-pole resolver 2-pole resolver	A E S T
Encoder systems for motors with DRIVE-CLiQ interface:	Incremental encoder sin/cos 1 V _{pp} 2048 pulses/revolution Absolute encoder EnDat 2048 pulses/revolution ¹⁾ Multi-pole resolver 2-pole resolver	D F U P
Shaft extension:	Radial eccentricity tolerance:	Holding brake:
Fitted key and keyway	N	without
Fitted key and keyway	N	with
Fitted key and keyway	R	without
Fitted key and keyway	R	with
Plain shaft	N	without
Plain shaft	N	with
Plain shaft	R	without
Plain shaft	R	with
Vibration severity grade:	Degree of protection: ⁴⁾	A B D E G H K L
N	IP64	0
N	IP65	1
R	IP64	3
R	IP65	4

To select the degree of protection and type, see "Selection guide".

Selection and ordering data

Motor type (continued)	Static current I_0 at M_0 $\Delta T=100$ K A	Calculated power $P_{\text{calc}} = M_0 \times n_{\text{rated}}/9550$ P_{calc} for M_0 $\Delta T=100$ K kW/HP	SINAMICS Motor Module		Power cable with complete shield Motor terminal (and brake terminal) via power connector		
			Rated output current I_{rated} A	Order No. For complete order no., see "SINAMICS S120"	Power connector Size	Motor cable cross section ⁶⁾ mm ²	Order no. Pre-assembled cable
1FT6084-8SF7...	18.2	8.2/11	18 ⁵⁾	6SL312 - 1TE21-8AA.	1.5	4 x 2.5	6FX 002-5 S31 -....
1FT6086-8SF7...	25	11.0/14.8	30	6SL312 - 1TE23-0AA.	1.5	4 x 4	6FX 002-5 S41 -....
1FT6105-8SF7...	42	20.4/27.4	45	6SL312 - 1TE24-5AA.	3	4 x 16	6FX 002-5 S23 -....
1FT6108-8SF7...	62	28.3/37.9	60 ⁵⁾	6SL312 - 1TE26-0AA.	3	4 x 16	6FX 002-5 S23 -....
1FT6132-6SF7...	69	34.6/46.4	85	6SL312 - 1TE28-5AA.	3	4 x 25	6FX 002-5 DS33 -....
1FT6134-6SF7...	83	44.0/6	85	6SL312 - 1TE28-5AA.	3	4 x 25	6FX 002-5 DS33 -....
1FT6136-6SF7...	110	55/73.8	132	6SL312 - 1TE31-3AA.	Terminal box (max. 4 x 35)		
1FT6084-8SH7...	26	12.3/16.5	30	6SL312 - 1TE23-0AA.	1.5	4 x 4	6FX 002-5 S41 -....
1FT6086-8SH7...	38	16.5/22.1	45	6SL312 - 1TE24-5AA.	3	4 x 16	6FX 002-5 S23 -....
1FT6105-8SH7...	59	30.6/41.0	85	6SL312 - 1TE28-5AA.	3	4 x 16	6FX 002-5 S23 -....
1FT6084-8SK7...	35	16.3/21.9	45	6SL312 - 1TE24-5AA.	1.5	4 x 10	6FX 002-5 S64 -....
1FT6086-8SK7...	44	22.0/29.5	45	6SL312 - 1TE24-5AA.	3	4 x 16	6FX 002-5 S23 -....

Cooling:

Internal air cooling
External air cooling

0
1

Motor Module:

Single Motor Module
Double Motor Module

1
2

Power cable model:

MOTION-CONNECT 800
MOTION-CONNECT 500

8
5

Without brake cores
With brake cores

C
D

For length code as well as power and signal cables, see "MOTION-CONNECT cables and connections".

Notes on forced ventilation

	Shaft heights 80 and 100	Shaft height 132
Direction of air flow	From NDE to DE	From DE to NDE
Connection system	Connector size 1	Terminal box
Type of connecting cable	6FX.002-5CA01-....	6FX.008-1BB11-
Pin and terminal assignments	Pin 1: L1, Pin 2: N	U1/L1: V2/L2: W3/L3
Supply voltage	220/260 V 1 AC, 50/60 Hz	400/460 V 3 AC, 50/60 Hz
Max. fan current	0.3 A	0.4 A
Weight of the fan module, approx.	4.8 kg (10.6 lb)	5.6 kg (12.3 lb)
Sound pressure level	70 dB (A)	74 dB (A)

¹⁾ If the absolute encoder is used, M_{rated} is reduced by 10%.

²⁾ Not for use in environments containing electrically conductive dust. Forced ventilation cannot be used in the presence of flammable, corrosive, electrically conductive or explosive dust.

³⁾ Same flange as for IM B5 type, but with metric threaded insert in the four mounting holes.

⁴⁾ The degree of protection refers to the motor. The built-on fan meets the requirements of degree of protection IP54.

⁵⁾ With the specified Motor Module, the motor cannot be fully utilized with M_0 at $\Delta T = 100$ K winding temperature rise.

⁶⁾ The current carrying capacity of the power cables corresponds to IEC 60204-1 for type of routing C under continuous operation conditions with an ambient air temperature of +40 °C (104 °F), designed for I_0 (100 K), PVC/PUR-insulated cable.

AC motors

Synchronous motors

1FT6 Big Servo motors Forced ventilation

Selection and ordering data

Rated speed	Shaft height	Rated power	Static torque	Rated torque	Rated current	1FT6 synchronous motors Big Servo Forced ventilation ¹⁾	Number of pole pairs	Rotor moment of inertia (without brake)	Weight (without brake)
n_{rated}		P_{rated} at $\Delta T=100\text{ K}$	M_0 at $\Delta T=100\text{ K}$	M_{rated} at $\Delta T=100\text{ K}$	I_{rated} at $\Delta T=100\text{ K}$	Order No.		J	
rpm	SH	kW/HP	Nm/lb _f -ft	Nm/lb _f -ft	A			10 ⁻⁴ kgm ² / lb _f -in-s ²	kg/lb
1500	160	60.5/81.1	425/313.2	385/283.7	136	1FT6163-8SB76 - ■■■■	4	2300/ 2.0357	170/ 374.8
		85/114.0	600/442.2	540/398	174	1FT6168-8SB76 - ■■■■	4	3100/ 2.7437	210/ 463
2500	160	89/119.4	425/313.2	340/250.6	185	1FT6163-8SD76 - ■■■■	4	2300/ 2.0357	170/ 374.8

Type ³⁾:	IM B35	6
Terminal box at top, cable entry:	Transverse right Transverse left Axial NDE Axial DE	5 6 7 8
Encoder systems for motors without DRIVE-CLiQ interface	Increment. encoder sin/cos 1 V _{pp} 2048 pulses/revolution Absolute encoder EnDat 2048 pulses/revolution Multi-pole resolver 2-pole resolver	A E S T
Encoder systems for motors with DRIVE-CLiQ interface	Increment. encoder sin/cos 1 V _{pp} 2048 pulses/revolution Absolute encoder EnDat 2048 pulses/revolution Multi-pole resolver 2-pole resolver	D F U P
Shaft extension:	Radial eccentricity tolerance:	Holding brake:
Fitted key and keyway	N	without
Fitted key and keyway	R	without
Plain shaft	N	without
Plain shaft	R	without
Vibration severity grade:		Degree of protection: ²⁾
N		IP64
N		IP65
R		IP64
R		IP65

To select the degree of protection and type, see "Selection guide".

Selection and ordering data

Motor type (continued)	Static current I_0 at $\Delta T=100\text{ K}$ A	Calculated power $P_{\text{calc}} = M_0 \times \frac{n_{\text{rated}}}{9550}$ P_{calc} for M_0 $\Delta T=100\text{ K}$ kW/HP	SINAMICS Motor Module Rated output current		Power cable with complete shield Motor connection via terminal box		
			$I_{\text{rated}}^{4)}$ A	Order No. For complete order no., see "SINAMICS S120"	Terminal box type cable gland	Max. connectable cable cross section mm ²	Order No. Power cable/ By the meter
1FT6163-8SB76-....	151	66.8/89.6	200	6SL312-1TE32-0AA0	gk 630 2 x M50 x 1.5	2 x 4 x 50	6FX 008-1BB50-
1FT6168-8SB76-....	194	94.2/126.3	200	6SL312-1TE32-0AA0	gk 630 2 x M50 x 1.5	2 x 4 x 50	6FX 008-1BB50-
1FT6163-8SD76-....	226	111/148.9	200	6SL312-1TE32-0AA0	gk 630 2 x M50 x 1.5	2 x 4 x 50	6FX 008-1BB50-
Cooling: Internal air cooling External air cooling				0 1			
Power cable model: MOTION-CONNECT 800 MOTION-CONNECT 500					8 5		
For length code as well as power and signal cables, see "MOTION-CONNECT cables and connections".							

Notes on forced ventilation

	Shaft height 160
Direction of air flow	From DE to NDE
Connection system	Terminal box
Type of connecting cable	6FX.008-1BB11-....
Pin and terminal assignments	U1/L1: V2/L2: W3/L3
Supply voltage	400/480 V 3 AC 50/60 Hz
Max. fan current	0.8 A
Sound pressure level	74 dB (A)

- Not for use in environments containing electrically conductive dust. Forced ventilation cannot be used in the presence of flammable, corrosive, electrically conductive or explosive dust.
- The degree of protection refers to the motor. The built-on fan meets the requirements of degree of protection IP54.

- 1FT616 Big Servo motors of construction type IM B35 can be mounted on the flange only.
- Motor Modules are assigned according to the motor rated current.

AC motors

Synchronous motors

1FT6 motors, standard type

Water cooling

Selection and ordering data

Rated speed	Shaft height	Rated power	Static torque	Rated torque	Rated current	1FT6 synchronous motors Water cooling ^{1) 2)}	Number of pole pairs	Rotor moment of inertia (without brake)	Weight (without brake)
n_{rated} rpm	SH	P_{rated} at $\Delta T=100$ K kW/HP	M_0 at $\Delta T=100$ K Nm/lb _f -ft	M_{rated} at $\Delta T=100$ K Nm/lb _f -ft	I_{rated} at $\Delta T=100$ K A	Order No. Standard type		J 10 ⁻⁴ kgm ² / lb _f -in-s ²	m kg/lb
1500	100	18.2/24.4	119/87.7	116/85.5	43	1FT6108-8WB7■ - ■■■■	4	260/0.2301	61.5/135.6
2000	100	17.2/23.1	85/62.6	82/60.4	60	1FT6105-8WC7■ - ■■■■	4	168/0.1487	45.5/100.3
		24.1/32.3	119/87.7	115/84.8	57	1FT6108-8WC7■ - ■■■■	4	260/0.2301	61.5/135.6
3000	63	3.2/4.3	10.2/7.5	10/7.4	6.9	1FT6062-6WF7■ - ■■■■	3	8.5/0.0075	9.5/20.9
		5.1/6.8	16.2/11.9	16/11.8	10.3	1FT6064-6WF7■ - ■■■■	3	13/0.0115	12.5/27.6
	80	11.0/14.8	35/25.8	35/25.8	27	1FT6084-8WF7■ - ■■■■	4	48/0.0425	21/46.3
		14.5/19.4	47/34.6	46/33.9	37	1FT6086-8WF7■ - ■■■■	4	66.5/0.0589	26/57.3
	100	24.5/32.9	85/62.6	78/57.5	82	1FT6105-8WF7■ - ■■■■	4	168/0.1487	45.5/100.3
		34.2/45.9	119/87.7	109/80.3	81	1FT6108-8WF7■ - ■■■■	4	260/0.2301	61.5/135.6
4500	63	4.7/6.3	10.2/7.5	10/7.4	9.6	1FT6062-6WH7■ - ■■■■	3	8.5/0.0075	9.5/20.9
		7.5/10.1	16.2/11.9	16/11.8	15.2	1FT6064-6WH7■ - ■■■■	3	13/0.0115	12.5/27.6
	80	16.5/22.1	35/25.8	35/25.8	39	1FT6084-8WH7■ - ■■■■	4	48/0.0425	21/46.3
		21.2/28.4	47/34.6	45/33.2	53	1FT6086-8WH7■ - ■■■■	4	66.5/0.0589	26/57.3
6000	63	6.2/8.3	10.2/7.5	9.8/7.2	12.7	1FT6062-6WK7■ - ■■■■	3	8.5/0.0075	9.5/20.9
		9.9/13.3	16.2/11.9	15.8/11.6	20	1FT6064-6WK7■ - ■■■■	3	13/0.0115	12.5/27.6
	80	21.4/28.7	35/25.8	34/25.1	51	1FT6084-8WK7■ - ■■■■	4	48/0.0425	21/46.3
		27.7/37.2	47/34.6	44/32.4	58	1FT6086-8WK7■ - ■■■■	4	66.5/0.0589	26/57.3

Type:	IM B5 IM B14 ³⁾ (not for 1FT613)	1 2
Connector outlet direction:	Transverse right (not for 1FT606) Transverse left (not for 1FT606) Axial non-drive end (NDE) Axial DE (1FT6062 only with water connect. on side or below) ²⁾	1 2 3 4
Terminal box/ cable entry: (only for 1FT61)	Transverse/from right Transverse/from left axial/from NDE axial/from DE	5 6 7 8
Encoder systems for motors without DRIVE-CLiQ interface:	Incremental encoder sin/cos 1 V _{pp} 2048 pulses/revolution Absolute encoder EnDat 2048 pulses/revolution Multi-pole resolver 2-pole resolver	A E S T
Encoder systems for motors with DRIVE-CLiQ interface:	Incremental encoder sin/cos 1 V _{pp} 2048 pulses/revolution Absolute encoder EnDat 2048 pulses/revolution Multi-pole resolver 2-pole resolver	D F U P
Shaft extension:	Radial eccentricity tolerance:	Holding brake:
Fitted key and keyway	N	without
Fitted key and keyway	N	with
Fitted key and keyway	R	without
Fitted key and keyway	R	with
Plain shaft	N	without
Plain shaft	N	with
Plain shaft	R	without
Plain shaft	R	with
Vibration severity grade:	Degree of protection:	A B D E G H K L
N	IP64	0
N	IP65	1
N	IP67	2
N	IP68	6
R	IP64	3
R	IP65	4
R	IP67	5
R	IP68	7

To select the degree of protection and type, see "Selection guide".

Selection and ordering data

Motor type (continued)	Static current I_0 at M_0 $\Delta T=100$ K A	Calculated power $P_{calc} = M_0 \times n_{rated}/9550$ P_{calc} for M_0 $\Delta T=100$ K kW/HP	SINAMICS Motor Module		Power cable with complete shield Motor terminal (and brake terminal) via power connector		
			Rated output current I_{rated} A	Order No. For complete order no., see "SINAMICS S120"	Power connector Size	Motor cable cross section ⁵⁾ mm ²	Order no. Pre-assembled cable
1FT6108-8WB7...	43	18.7/25.1	45	6SL312-1TE24-5AA.	3	4 x 16	6FX002-5S23-....
1FT6105-8WC7...	58	17.8/23.9	60	6SL312-1TE26-0AA.	3	4 x 16	6FX002-5S23-....
1FT6108-8WC7...	57	24.9/33.4	60	6SL312-1TE26-0AA.	3	4 x 16	6FX002-5S23-....
1FT6062-6WF7...	6.9	3.2/4.3	9	6SL312-TE21-0AA.	1	4 x 1.5	6FX002-5S01-....
1FT6064-6WF7...	10.3	5.1/6.8	18	6SL312-TE21-8AA.	1	4 x 1.5	6FX002-5S01-....
1FT6084-8WF7...	24.5	11.0/14.8	30	6SL312-1TE23-0AA.	1.5	4 x 4	6FX002-5S41-....
1FT6086-8WF7...	34	14.8/19.9	45	6SL312-1TE24-5AA.	1.5	4 x 10	6FX002-5S64-....
1FT6105-8WF7...	83	26.7/35.8	85	6SL312-1TE28-5AA.	3	4 x 25	6FX5002-5DS33-....
1FT6108-8WF7...	86	37.4/50.2	85 ⁴⁾	6SL312-1TE28-5AA.	3	4 x 35	6FX5002-5DS43-....
1FT6062-6WH7...	9.7	4.8/6.4	18	6SL312-TE21-8AA.	1	4 x 1.5	6FX002-5S01-....
1FT6064-6WH7...	15.4	7.6/10.2	18	6SL312-TE21-8AA.	1	4 x 2.5	6FX002-5S11-....
1FT6084-8WH7...	37	16.5/22.1	45	6SL312-1TE24-5AA.	1.5	4 x 10	6FX002-5S64-....
1FT6086-8WH7...	52	22.1/29.6	60	6SL312-1TE26-0AA.	3	4 x 16	6FX002-5S23-....
1FT6062-6WK7...	12.9	6.4/8.6	18	6SL312-TE21-8AA.	1	4 x 1.5	6FX002-5S01-....
1FT6064-6WK7...	20.5	10.2/13.7	30	6SL312-1TE23-0AA.	1	4 x 2.5	6FX002-5S11-....
1FT6084-8WK7...	47	22.0/29.5	60	6SL312-1TE26-0AA.	3	4 x 16	6FX002-5S23-....
1FT6086-8WK7...	59	29.5/39.6	60	6SL312-1TE26-0AA.	3	4 x 16	6FX002-5DS23-....
Cooling: Internal air cooling External air cooling				0 1			
Motor Module: Single Motor Module Double Motor Module				1 2			
Power cable model: MOTION-CONNECT 800 MOTION-CONNECT 500					8 5		
Without brake cores With brake cores							C D
For length code as well as power and signal cables, see "MOTION-CONNECT cables and connections".						

Notes on water cooling:

- Inlet temperature of cooling water: max. 30 °C (86 °F)
- Cooling water throughput: at least 5 l/min (1.1 British gallons/1.32 US gallons)
- Pressure ahead of motor: $p_{max} = 3$ bar (43.5 psi)
- Cooling water connection: G 3/8"
- Coolant: Water with up to 25% corrosion protection (recommendation: Tyfocor)
- Loss of pressure between inlet and outlet < 0.1 bar (1.45 psi)

¹⁾ Delivered as standard with water connection "at top".

²⁾ Water connection on right side: Order code **Q20**
Water connection on left side: Order code **Q21**
Water connection at bottom: Order code **Q22**

³⁾ Same flange as for IM B5 type, but with metric threaded insert in the four mounting holes.

⁴⁾ With the specified Motor Module, the motor cannot be fully utilized with M_0 at $\Delta T = 100$ K winding temperature rise. If a Motor Module with a higher rating is used, you must check whether the specified power cable can be connected to it.

⁵⁾ The current carrying capacity of the power cables corresponds to IEC 60204-1 for type of routing C under continuous operation conditions with an ambient air temperature of +40 °C (104 °F), designed for I_0 (100 K), PVC/PUR-insulated cable.

AC motors

Synchronous motors

1FT6 Big Servo motors Water cooling

Selection and ordering data

Rated speed	Shaft height	Rated power	Static torque	Rated torque	Rated current	1FT6 synchronous motors Big Servo Water cooling	Number of pole pairs	Rotor moment of inertia (without brake)	Weight (without brake)
n_{rated}	SH	P_{rated} at $\Delta T=100$ K	M_0 at $\Delta T=100$ K	M_{rated} at $\Delta T=100$ K	I_{rated} at $\Delta T=100$ K	Order No.		J	m
rpm		kW/HP	Nm/lb _f -ft	Nm/lb _f -ft	A			10 ⁻⁴ kgm ² / lb _f -in ⁻²	kg/lb
1500	132	23.6/31.7	155/114.2	150/110.6	58	1FT6132-6WB76 - ■■■■	3	430/0.3805	90/198.5
		29.1/39.0	200/147.4	185/136.6	67	1FT6134-6WB76 - ■■■■	3	547/0.4841	103/227.1
		36.1/48.4	240/176.9	230/169.5	90	1FT6136-6WB76 - ■■■■	3	665/0.5885	120/264.6
		45.5/61.0	300/221.1	290/213.7	112	1FT6138-6WB76 - ■■■■	3	845/0.7478	137/302.1
	160	70.7/94.8	450/331.7	450/331.7	160	1FT6163-8WB76 - ■■■■	4	2300/2.0357	170/374.8
		108.4/145.4	700/515.9	690/508.5	221	1FT6168-8WB76 - ■■■■	4	3100/2.7437	210/463
2500	132	35.3/47.3	155/114.2	135/99.5	82	1FT6132-6WD76 - ■■■■	3	430/0.3805	90/198.5
		48.4/64.9	200/147.4	185/136.3	115	1FT6134-6WD76 - ■■■■	3	547/0.4841	103/227.1
		57.6/77.2	240/176.9	220/162.1	149	1FT6136-6WD76 - ■■■■	3	665/0.5885	120/264.6
		72.0/96.6	300/221.1	275/202.7	162	1FT6138-6WD76 - ■■■■	3	845/0.7874	137/302.1
	160	117.8/158.0	450/331.7	450/331.7	240	1FT6163-8WD76 - ■■■■	4	2300/2.0357	170/374.8

Type ¹⁾ :	IM B35	6		
Terminal box/ cable entry:	Transverse/from right Transverse/from left Axial/from NDE Axial/from DE	5 6 7 8		
Encoder systems for motors without DRIVE-CLiQ interface:	Incremental encoder sin/cos 1 V _{pp} 2048 pulses/revolution Absolute encoder EnDat 2048 pulses/revolution Multi-pole resolver 2-pole resolver	A E S T		
Encoder systems for motors with DRIVE-CLiQ interface:	Incremental encoder sin/cos 1 V _{pp} 2048 pulses/revolution Absolute encoder EnDat 2048 pulses/revolution Multi-pole resolver 2-pole resolver	D F U P		
Shaft extension:	Radial eccentricity tolerance:	Holding brake:		A D G K
Fitted key and keyway Fitted key and keyway Plain shaft Plain shaft	N R N R	without without without without		
Vibration severity grade:	Degree of protection:			0 1 3 4
N N R R	IP64 IP65 IP64 IP65			

To select the degree of protection, see "Selection guide".

Selection and ordering data

Motor type (continued)	Static current I_0 at M_0 $\Delta T=100$ K A	Calculated power $P_{calc} = M_0 \times$ $n_{rated}/9550$ P_{calc} for M_0 $\Delta T=100$ K kW/HP	SINAMICS Motor Module		Power cable with complete shield Motor terminal via terminal box		
			Rated output current I_{rated} A	Order No. For complete order no., see "SINAMICS S120"	Terminal box type cable gland	Max. connectable cable cross section mm ²	Order No. Power cable By the meter
1FT6132-6WB76-...	58	24.3/23.6	60	6SL312 -1TE 26-0AA.	gk 630 2 x M32 x 1.5	2 x 4 x 16	6FX008-1BB61-....
1FT6134-6WB76-...	73	31.4/42.1	85	6SL312 -1TE 28-5AA.	gk 630 2 x M40 x 1.5	2 x 4 x 35	6FX008-1BB35-....
1FT6136-6WB76-...	92	37.7/50.6	132	6SL312 -1TE 31-3AA.	gk 630 2 x M50 x 1.5	2 x 4 x 50	6FX008-1BB50-....
1FT6138-6WB76-...	112	47.1/63.2	132	6SL312 -1TE 31-3AA.	gk 630 2 x M50 x 1.5	2 x 4 x 50	6FX008-1BB50-....
1FT6163-8WB76-...	160	70.7/94.8	200	6SL312 -1TE 32-0AA.	gk 630 2 x M50 x 1.5	2 x 4 x 50	6FX008-1BB50-....
1FT6168-8WB76-...	225	110/147.5	260	6SL3320 -1TE 32-6AA0	gk 630 2 x M50 x 1.5	2 x 4 x 50	6FX008-1BB50-....
1FT6132-6WD76-...	92	40.6/54.4	85	6SL312 -1TE 28-5AA.	gk 630 2 x M40 x 1.5	2 x 4 x 35	6FX008-1BB35-....
1FT6134-6WD76-...	122	52.4/70.3	132	6SL312 -1TE 31-3AA.	gk 630 2 x M50 x 1.5	2 x 4 x 50	6FX008-1BB50-....
1FT6136-6WD76-...	158	62.8/84.2	200	6SL312 -1TE 32-0AA.	gk 630 2 x M50 x 1.5	2 x 4 x 50	6FX008-1BB50-....
1FT6138-6WD76-...	167	78.5/105.3	200	6SL312 -1TE 32-0AA.	gk 630 2 x M50 x 1.5	2 x 4 x 50	6FX008-1BB50-....
1FT6163-8WD76-...	240	118/158.2	260	6SL3320 -1TE 32-6AA0	gk 630 2 x M50 x 1.5	2 x 4 x 50	6FX008-1BB50-....
Cooling:							
Internal air cooling							0
External air cooling							1
Motor Module:							
Single Motor Module							1
Power cable model:							
MOTION-CONNECT 800							8
MOTION-CONNECT 500							5
For length code as well as power and signal cables, see "MOTION-CONNECT cables and connections".							

Notes on water cooling

- Inlet temperature of cooling water: max. 30 °C (86 °F)
- Cooling water throughput:
at least 8 l/min (1.76 British gallons/2.11 US gallons)
with 1FT613.
at least 10 l/min (2.2 British gallons/2.64 US gallons)
with 1FT616.
- Pressure ahead of motor: $p_{max} = 6$ bar (87 psi)
- Cooling water connection: G 3/8" with 1FT613.
G 1/2" with 1FT616.
- Coolant: Water with up to max. 25% corrosion protection,
(recommendation: Tyfocor)
- Loss of pressure between inlet and outlet < 0.1 bar (1.45 psi)

1) 1FT616 Big Servo motors of construction type IM B35 can be mounted on the flange only.

AC motors

Synchronous motors

1FK7 motors

Overview



1FK7 motors are extremely compact, permanent-magnet synchronous motors. The available options, gearboxes and encoders, together with the expanded product range, mean that 1FK7 motors can be easily adapted to any application. They satisfy the ever-increasing demands of state-of-the-art machines.

1FK7 motors can be combined with the SINAMICS S drive system to create a powerful, high-performance system. The integrated encoder systems for speed and position control can be selected depending on the application.

The motors are designed for operation without external cooling and the heat is dissipated through the motor surface. 1FK7 motors have a high overload capability.

Benefits

1FK7 Compact motors offer:

- Space-saving installation due to extremely high power density
- For universal applications
- Wide range of motors

1FK7 High Dynamic motors offer:

- Extremely high dynamic response from low rotor moment of inertia

Applications

- Machine tools
- Robots and manipulators
- Wood, glass, ceramics and stone working
- Packaging, plastics and textile machines
- Auxiliary axes

Technical data

Type of motor	Permanent-magnet synchronous motor
Magnet material	Rare-earth magnet material
Insulation of the stator winding to EN 60034-1 (IEC 60034-1)	Thermal Class F for a winding temperature rise of $\Delta T = 100 \text{ K}$ at an ambient temperature of 40 °C ($+104\text{°F}$)
Type according to EN 60034-7 (IEC 60034-7)	IM B5 (IM V1, IM V3)
Degree of protection according to EN 60034-5 (IEC 60034-5)	IP64
Cooling	Natural cooling
Temperature monitoring	KTY 84 temperature sensor in stator winding
Paint finish	Unpainted
Shaft end on the drive end to DIN 748-3 (IEC 60072-1)	Plain shaft
2nd rating plate	Glued to end shield
3rd rating plate	Enclosed separately
Radial eccentricity, concentricity and axial eccentricity in accordance with DIN 42955 (IEC 60072-1)	Tolerance N (normal)
Vibration severity to EN 60034-14 (IEC 60034-14)	Grade N (normal)
Noise pressure level to DIN EN ISO 1680, max.	1FK701: 55 dB(A) 1FK702: 55 dB(A) 1FK703: 55 dB(A) 1FK704: 55 dB(A) 1FK706: 65 dB(A) 1FK708: 70 dB(A) 1FK710: 70 dB(A)
Encoder systems, built-in, for motors with/without DRIVE-CLiQ interface	<ul style="list-style-type: none"> • Incremental encoder sin/cos 1 V_{pp} 2048 pulses/revolution • Absolute encoder, multiturn, 2048 pulses/revolution for 1FK704 to 1FK710. 512 pulses/revolution on 1FK701 to 1FK703 und traversing range 4096 revolutions with EnDat interface • Basic absolute encoder, multiturn, 32 pulses/revolution on 1FK704 to 1FK710 and traversing range 4096 revolutions with EnDat interface • Multi-pole resolver (number of poles corresponds to number of pole pairs of the motor) • 2-pole resolver
Connection	Connectors for signals and power can be rotated (270°)
Options	<ul style="list-style-type: none"> • Shaft extension at the drive end with fitted key and keyway (half-key balancing) • Integrated holding brake • Degree of protection IP65, drive end flange IP67 • Planetary gear unit (requires: plain shaft end and degree of protection IP65) • Anthracite finish RAL 7016

Characteristics

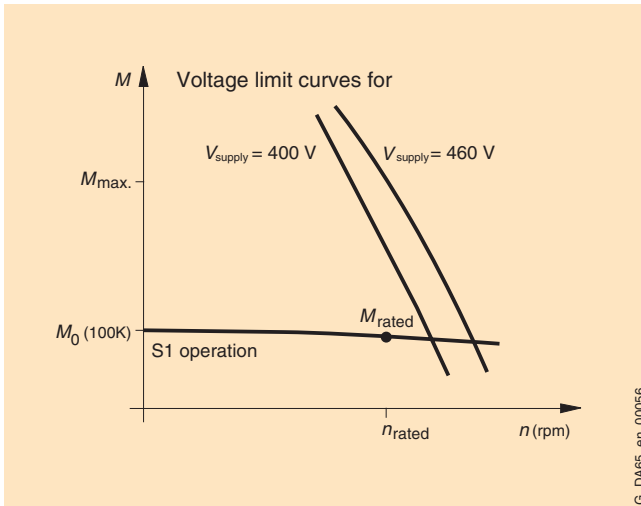

Speed-torque characteristic

Options

Order code	Option description	1FK7 Compact	1FK7 High Dynamic
M03	Version for Zone 2 hazardous areas (in accordance with EN 50021/ IEC 60079-15)	■	■
M39	Version for Zone 22 hazardous areas (in accordance with EN 50281/ IEC 61241)	■	■
N05	Non-standard shaft extension (dimensions as for 1FT5 motors)	■	■
X01	Jet black finish RAL 9005	■	■
X02	Cream finish RAL 9001	■	■
X03	Reseda green finish RAL 6011	■	■
X04	Pebble gray finish RAL 7032	■	■
X05	Sky blue finish RAL 5015	■	■
X06	Light ivory finish RAL 1015	■	■
X08	White aluminum RAL 9006, suitable for use with food	■	■

■ Option available

AC motors

Synchronous motors

1FK7 Compact motors Natural cooling

Selection and ordering data

Rated speed	Shaft height	Rated power	Static torque	Rated torque ¹⁾	Rated current	1FK7 synchronous motor Compact natural cooling	Number of pole pairs	Rotor moment of inertia (without brake)	Weight (without brake)
n_{rated}	SH	P_{rated} at $\Delta T=100$ K	M_0 at $\Delta T=100$ K	M_{rated} at $\Delta T=100$ K	I_{rated} at $\Delta T=100$ K	Order No.		J	m
rpm		kW/HP	Nm/lb _f -ft	Nm/lb _f -ft	A			10 ⁻⁴ kgm ² / lb _f -in ⁻²	kg/lb
2000	100	7.75/10.4	48/35.4	37/27.3	16	1FK7105-5AC71-1 ■ ■ ■ ■	4	156/0.1381	39/86.2
3000	48	0.82/1.1	3/2.2	2.6/1.9	1.95	1FK7042-5AF71-1 ■ ■ ■ ■	4	3.01/0.0027	4.9/10.8
	63	1.48/2.0	6/4.4	4.7/3.5	3.7	1FK7060-5AF71-1 ■ ■ ■ ■	4	7.95/0.0070	7/15.4
		2.29/3.1	11/8.1	7.3/5.4	5.6	1FK7063-5AF71-1 ■ ■ ■ ■	4	15.1/0.0134	11.5/25.4
	80	2.14/2.9	8/5.9	6.8/5	4.4	1FK7080-5AF71-1 ■ ■ ■ ■	4	15/0.0133	10/22.1
		3.3/4.4	16/11.8	10.5/7.7	7.4	1FK7083-5AF71-1 ■ ■ ■ ■	4	27.3/0.0242	14/30.9
100	3.77/5.1	18/13.3	12/8.8	8	1FK7100-5AF71-1 ■ ■ ■ ■	4	55.3/0.0489	19/41.9	
	4.87/6.5	27/19.9	15.5/11.4	11.8	1FK7101-5AF71-1 ■ ■ ■ ■	4	79.9/0.0707	21/46.3	
	5.37/7.2 ²⁾	36/26.5	20.5/15.1 ²⁾	16.5 ²⁾	1FK7103-5AF71-1 ■ ■ ■ ■	4	105/0.0929	29/63.9	
	8.17/11.0	48/35.4	26/19.2	18	1FK7105-5AF71-1 ■ ■ ■ ■	4	156/0.1381	39/86.2	
	4500	63	1.74/2.3	6/4.4	3.7/2.7	4.1	1FK7060-5AH71-1 ■ ■ ■ ■	4	7.95/0.0070
		2.09/2.8 ³⁾	11/8.1	5/3.7 ³⁾	6.1 ³⁾	1FK7063-5AH71-1 ■ ■ ■ ■	4	15.1/0.0134	11.5/25.4
	80	2.39/3.2 ³⁾	8/5.9	5.7/4.2 ³⁾	5.6 ³⁾	1FK7080-5AH71-1 ■ ■ ■ ■	4	15/0.0133	10/22.1
		3.04/4.1 ⁴⁾	16/11.8	8.3/6.1 ⁴⁾	9 ⁴⁾	1FK7083-5AH71-1 ■ ■ ■ ■	4	27.3/0.0242	14/30.9
6000	20	0.05/0.1	0.18/0.1	0.08/0.1	0.85	1FK7011-5AK71-1 ■ ■ ■ ■ 3	4	0.064/0.0001	0.9/2
		0.10/0.1	0.35/0.3	0.16/0.1	0.85	1FK7015-5AK71-1 ■ ■ ■ ■ 3	4	0.083/0.0001	1.1/2.4
	28	0.43/0.6	0.85/0.6	0.6/0.4	1.4	1FK7022-5AK71-1 ■ ■ ■ ■	3	0.28/0.0002	1.8/4
	36	0.50/0.7	1.1/0.8	0.8/0.6	1.3	1FK7032-5AK71-1 ■ ■ ■ ■	3	0.61/0.0005	2.7/6
		0.63/0.8	1.6/1.2	1/0.7	1.3	1FK7034-5AK71-1 ■ ■ ■ ■	3	0.9/0.0008	3.7/8.2
48	0.69/0.9	1.6/1.2	1.1/0.8	1.7	1FK7040-5AK71-1 ■ ■ ■ ■	4	1.69/0.0015	3.5/7.7	
		1.02/1.4 ⁵⁾	3/2.2	1.95/1.4 ⁵⁾	3.1 ⁵⁾	1FK7042-5AK71-1 ■ ■ ■ ■	4	3.01/0.0027	4.9/10.8

Encoder systems for motors without DRIVE-CLiQ interface: Incremental encoder sin/cos 1 V_{pp} 2048 pulses/revolution
Abs. encoder EnDat 2048 pulses/rev. ¹⁾ (not for 1FK701 to 1FK703)
Abs. encoder EnDat 512 pulses/rev. ¹⁾ (only for 1FK701 to 1FK703)
Basic absolute encoder EnDat 32 pulses/revolution ¹⁾
(not for 1FK701 to 1FK703)
Multi-pole resolver
2-pole resolver

A
E
H
G
S
T

Encoder systems for motors with DRIVE-CLiQ interface ⁸⁾: Increm. encoder sin/cos 1 V_{pp} 2048 pulses/rev. (not for 1FK701)
Abs. encoder EnDat 2048 pulses/rev. ¹⁾ (not for 1FK701 to 1FK703)
Abs. encoder EnDat 512 pulses/rev. ¹⁾ (only for 1FK702/1FK703)
Basic absolute encoder EnDat 32 pulses/revolution ¹⁾
(not for 1FK701 to 1FK703)
Multi-pole resolver (not for 1FK701)
2-pole resolver (not for 1FK701)

D
F
L
K
U
P

Shaft extension:	Radial eccentricity tolerance:	Holding brake:
Fitted key and keyway	N	without
Fitted key and keyway	N	with
Plain shaft	N	without
Plain shaft	N	with

A
B
G
H

Degree of protection: IP64
IP65, drive end flange IP67
IP64 (IP54 for 1FK701) and anthracite paint finish
IP65, drive end flange IP67, anthracite paint finish

0
2
3
5

To select the degree of protection and type, see "Selection guide".



Selection and ordering data

Motor type (continued)	Static current I_0 at M_0 $\Delta T = 100$ K A	Calculated power $P_{calc} = M_0 \times n_{rated} / 9550$ P_{calc} for M_0 $\Delta T = 100$ K kW/HP	SINAMICS Motor Module		Power cable with complete shield Motor terminal (and brake terminal) via power connector		
			Rated output current I_{rated} A	Order No. For complete order no., see "SINAMICS S120"	Power connector Size	Motor cable cross section ⁷⁾ mm ²	Order no. Pre-assembled cable
1FK7105-5AC71...	20	10/13.4	30	6SL312-TE23-0AA.	1.5	4 x 2.5	6FX002-5S31-....
1FK7042-5AF71...	2.2	0.9/1.2	3	6SL312-TE13-0AA.	1	4 x 1.5	6FX002-5S01-....
1FK7060-5AF71...	4.5	1.9/2.6	5	6SL312-TE15-0AA.	1	4 x 1.5	6FX002-5S01-....
1FK7063-5AF71...	8	3.5/4.7	9	6SL312-TE21-0AA.	1	4 x 1.5	6FX002-5S01-....
1FK7080-5AF71...	4.8	2.5/3.4	5	6SL312-TE15-0AA.	1	4 x 1.5	6FX002-5S01-....
1FK7083-5AF71...	10.4	5.0/6.7	9 ⁶⁾	6SL312-TE21-0AA.	1	4 x 1.5	6FX002-5S01-....
1FK7100-5AF71...	11.2	5.7/7.6	18	6SL312-TE21-8AA.	1	4 x 1.5	6FX002-5S01-....
1FK7101-5AF71...	19	8.5/11.4	18 ⁶⁾	6SL312-TE21-8AA.	1.5	4 x 2.5	6FX002-5S31-....
1FK7103-5AF71...	27.5	11.3/15.2	30	6SL312-1TE23-0AA.	1.5	4 x 4	6FX002-5S41-....
1FK7105-5AF71...	31	15/20.1	30 ⁶⁾	6SL312-1TE23-0AA.	1.5	4 x 10	6FX002-5S61-....
1FK7060-5AH71...	6.2	2.8/3.8	9	6SL312-TE21-0AA.	1	4 x 1.5	6FX002-5S01-....
1FK7063-5AH71...	12	5.2/7.0	18	6SL312-TE21-8AA.	1	4 x 1.5	6FX002-5S01-....
1FK7080-5AH71...	7.4	3.8/5.1	9	6SL312-TE21-0AA.	1	4 x 1.5	6FX002-5S01-....
1FK7083-5AH71...	15	7.5/10.1	18	6SL312-TE21-8AA.	1	4 x 1.5	6FX002-5S01-....
1FK7011-5AK71...	1.5	0.11/0.2	3	6SL312-TE13-0AA.	0.5	4 x 1.5	6FX5002-5DA20-....
1FK7015-5AK71...	1.5	0.22/0.3	3	6SL312-TE13-0AA.	0.5	4 x 1.5	6FX5002-5DA20-....
1FK7022-5AK71...	1.8	0.5/0.7	3	6SL312-TE13-0AA.	1	4 x 1.5	6FX002-5S01-....
1FK7032-5AK71...	1.7	0.7/0.9	3	6SL312-TE13-0AA.	1	4 x 1.5	6FX002-5S01-....
1FK7034-5AK71...	1.9	1/1.3	3	6SL312-TE13-0AA.	1	4 x 1.5	6FX002-5S01-....
1FK7040-5AK71...	2.25	1.0/1.3	3	6SL312-TE13-0AA.	1	4 x 1.5	6FX002-5S01-....
1FK7042-5AK71...	4.4	1.9/2.6	5	6SL312-TE15-0AA.	1	4 x 1.5	6FX002-5S01-....

Cooling:

Internal air cooling
External air cooling

0
1

Motor Module:

Single Motor Module
Double Motor Module

1
2

Power cable model:

MOTION-CONNECT 800
MOTION-CONNECT 500

8
5

Without brake cores
With brake cores

C
D

For length code as well as power and signal cables, see "MOTION-CONNECT cables and connections".

....

- 1) If the absolute encoder is used, M_{rated} is reduced by 10%.
- 2) These values refer to $n = 2500$ rpm.
- 3) These values refer to $n = 4000$ rpm.
- 4) These values refer to $n = 3500$ rpm.
- 5) These values refer to $n = 5000$ rpm.
- 6) With the specified Motor Module, the motor cannot be utilized with M_0 at $\Delta T = 100$ K winding temperature rise. If a Motor Module with a higher rating is used, you must check whether the specified power cable can be connected to it.

- 7) The current carrying capacity of the power cables corresponds to IEC 60204-1 for type of routing C under continuous operation conditions with an ambient air temperature of +40 °C (104 °F), designed for I_0 (100 K), PVC/PUR-insulated cable.
- 8) Motors in shaft height 20 are not available with a DRIVE-CLiQ interface. The encoder systems are connected via the SMC (Sensor Modul Cabinet-Mounted).

AC motors

Synchronous motors

1FK7 High Dynamic motors Natural cooling

Selection and ordering data

Rated speed	Shaft height	Rated power	Static torque	Rated torque ¹⁾	Rated current	1FK7 High Dynamic synchronous motor with natural cooling	Number of pole pairs	Rotor moment of inertia (without brake)	Weight (without brake)
n_{rated}	SH	P_{rated} at $\Delta T=100$ K	M_0 at $\Delta T=100$ K	M_{rated} at $\Delta T=100$ K	I_{rated} at $\Delta T=100$ K	Order No.		J	m
rpm		kW/HP	Nm/lb _f -ft	Nm/lb _f -ft	A			10 ⁻⁴ kgm ² /lb _f -in ⁻²	kg/lb
3000	48	1.1/1.48	4/2.9	3.5/2.6	4	1FK7044-7AF71-1 ■ ■ ■ ■	3	1.28/0.0011	7.7/17
	63	1.7/2.28	6.4/4.7	5.4/4	5.3	1FK7061-7AF71-1 ■ ■ ■ ■	3	3.4/0.0030	10/22.1
		2.51/3.37	12/8.8	8/5.9	7.5	1FK7064-7AF71-1 ■ ■ ■ ■	3	6.5/0.0058	15.5/34.2
	80	3.14/4.21 ²⁾	22/89.9	12/8.8 ²⁾	12.5 ²⁾	1FK7085-7AF71-1 ■ ■ ■ ■	4	23/0.0204	23.5/51.8
3.77/5.06 ³⁾		28/20.6	18/13.3 ³⁾	14.5 ³⁾	1FK7086-7AF71-1 ■ ■ ■ ■	4	23/0.0204	23.5/51.8	
4500	48	1.23/1.65	3.1/2.3	2.6/1.9	4	1FK7043-7AH71-1 ■ ■ ■ ■	3	1/0.0009	6.3/13.9
		1.41/1.89	4/2.9	3/2.2	4.9	1FK7044-7AH71-1 ■ ■ ■ ■	3	1.28/0.0011	7.7/17
	63	2.03/2.72	6.4/4.7	4.3/3.2	5.9	1FK7061-7AH71-1 ■ ■ ■ ■	3	3.4/0.0030	10/22.1
		2.36/3.16	12/8.8	5/3.7	7	1FK7064-7AH71-1 ■ ■ ■ ■	3	6.5/0.0058	15.5/34.2
6000	36	0.57/0.76	1.3/1	0.9/0.7	1.5	1FK7033-7AK71-1 ■ ■ ■ ■	3	0.27/0.0002	3.1/6.8
	48	1.26/1.69	3.1/2.3	2/1.5	4.4	1FK7043-7AK71-1 ■ ■ ■ ■	3	1/0.0009	6.3/13.9
Encoder systems for motors without DRIVE-CLiQ interface:		Incremental encoder sin/cos 1 V _{pp} 2048 pulses/revolution Absolute encoder EnDat 2048 pulses/revolution ¹⁾ (not for 1FK703) Absolute encoder EnDat 512 pulses/revolution ¹⁾ (only for 1FK703) Basic absolute encoder EnDat 32 pulses/rev. ¹⁾ (not for 1FK703) Multi-pole resolver 2-pole resolver				A E H G S T			
Encoder systems for motors mit DRIVE-CLiQ-Schnittstelle:		Incremental encoder sin/cos 1 V _{pp} 2048 pulses/revolution Absolute encoder EnDat 2048 pulses/rev. ¹⁾ (not for 1FK703) Absolute encoder EnDat 512 pulses/revolution ¹⁾ (only for 1FK703) Basic absolute encoder EnDat 32 pulses/rev. ¹⁾ (not for 1FK703) Multi-pole resolver 2-pole resolver				D F L K U P			
Shaft extension:		Radial eccentricity tolerance:		Holding brake:					
Fitted key and keyway		N		without					
Fitted key and keyway		N		with					
Plain shaft		N		without					
Plain shaft		N		with					
Degree of protection:		IP64 IP65 and IP67 drive end flange IP64, anthracite paint finish IP65 and drive end flange IP67, anthracite paint finish						0 2 3 5	

To select the degree of protection and type, see "Selection guide".

Selection and ordering data

Motor type (continued)	Static current I_0 at M_0 $\Delta T=100$ K A	Calculated power $P_{calc} = M_0 \times$ $n_{rated}/9550$ P_{calc} for M_0 $\Delta T=100$ K kW/HP	SINAMICS Motor Module		Power cable with complete shield Motor terminal (and brake terminal) via power connector		
			Rated output current I_{rated} A	Order No. For complete order no., see "SINAMICS S120"	Power con- nector Size	Motor cable cross section ⁴⁾ mm ²	Order no. Pre-assembled cable
1FK7044-7AF71...	4.5	1.3/1.7	5	6SL312-TE15-0AA.	1	4 x 1.5	6FX002-5S01-....
1FK7061-7AF71...	6.1	2.0/2.7	9	6SL312-TE21-0AA.	1	4 x 1.5	6FX002-5S01-....
1FK7064-7AF71...	11	3.8/5.1	18	6SL312-TE21-8AA.	1	4 x 1.5	6FX002-5S01-....
1FK7085-7AF71...	22.5	6.9/9.3	30	6SL312-1TE23-0AA.	1.5	4 x 4	6FX002-5S41-....
1FK7086-7AF71...	21	8.8/11.8	30	6SL312-1TE23-0AA.	1.5	4 x 4	6FX002-5S41-....
1FK7043-7AH71...	4.5	1.5/2.0	5	6SL312-TE15-0AA.	1	4 x 1.5	6FX002-5S01-....
1FK7044-7AH71...	6.3	1.9/2.6	9	6SL312-TE21-0AA.	1	4 x 1.5	6FX002-5S01-....
1FK7061-7AH71...	8	3.0/4.0	9	6SL312-TE21-0AA.	1	4 x 1.5	6FX002-5S01-....
1FK7064-7AH71...	15	5.7/7.6	18	6SL312-TE21-8AA.	1	4 x 1.5	6FX002-5S01-....
1FK7033-7AK71...	2.2	0.8/1.1	3	6SL312-TE13-0AA.	1	4 x 1.5	6FX002-5S01-....
1FK7043-7AK71...	6.4	1.9/2.6	9	6SL312-TE21-0AA.	1	4 x 1.5	6FX002-5S01-....

Cooling:

Internal air cooling
External air cooling

0
1

Motor Module:

Single Motor Module
Double Motor Module

1
2

Power cable model:

MOTION-CONNECT 800
MOTION-CONNECT 500

8
5

Without brake cores
With brake cores

C
D

For length code as well as power and signal cables, see "MOTION-CONNECT cables and connections".

....

¹⁾ If the absolute encoder is used, M_{rated} is reduced by 10%.

²⁾ These values refer to $n = 2500$ rpm.

³⁾ These values refer to $n = 2000$ rpm.

⁴⁾ The current carrying capacity of the power cable corresponds to IEC 60204-1 for type of routing C under continuous operating conditions with an ambient air temperature of +40 °C (104 °F), designed for I_0 (100 K), PVC/PUR-insulated cable.

AC motors

Synchronous motors

1FK7 Compact/High Dynamic motors Natural cooling on Power Module

Selection and ordering data

Rated speed	Shaft height	Rated power	Static torque	Rated torque	Rated current	1FK7 Compact/High Dynamic synchronous motor Natural cooling Connection to SINAMICS 230 V 1 AC	Number of pole pairs	Rotor moment of inertia (without brake)	Weight (without brake)
n_{rated}	SH	P_{rated} at $\Delta T=100\text{ K}$	M_0 at $\Delta T=100\text{ K}$	M_{rated} at $\Delta T=100\text{ K}$	I_{rated} at $\Delta T=100\text{ K}$	Order No.		J	m
rpm		kW/HP	Nm/lb _f -ft	Nm/lb _f -ft	A			$10^{-4}\text{ kgm}^2/\text{lb}_f\text{-in-s}^2$	kg/lb
3000	36	0.31/0.42	1.15/0.8	1.0/0.7	1.6	1FK7032-5AF21-1 ■ ■ ■	3	0.61/0.0005	2.7/5.9
		0.38/0.51	1.3/1	1.2/0.9	2	1FK7033-7AF21-1 ■ ■ ■	3	0.27/0.0002	3.1/6.8
		0.46/0.62	1.6/1.2	1.45/1.1	1.8	1FK7034-5AF21-1 ■ ■ ■	3	0.9/0.0008	3.7/8.2
	48	0.82/1.1	3/2.2	2.6/1.9	3.5	1FK7042-5AF21-1 ■ ■ ■	4	3.01/0.0027	4.9/10.8
		0.79/1.06	2.7/2	2.5/1.8	3.8	1FK7043-7AF21-1 ■ ■ ■	3	1/0.0009	6.3/13.9
6000	20	0.05/0.1	0.18/0.1	0.08/0.1	0.5	1FK7011-5AK21-1 ■ ■ ■ 3	4	0.064/0.0001	0.9/2
		0.1/0.1	0.35/0.3	0.16/0.1	0.5	1FK7015-5AK21-1 ■ ■ ■ 3	4	0.083/0.0001	1.1/2.4
	28	0.38/0.51	0.85/0.6	0.6/0.4	1.4	1FK7022-5AK21-1 ■ ■ ■	3	0.28/0.0002	1.8/4
Encoder systems for motors without DRIVE-CLiQ interface:		Incremental encoder sin/cos 1 V _{pp} 2048 pulses/revolution Absolute encoder EnDat 2048 pulses/rev. (only for 1FK704) ¹⁾ Absolute encoder EnDat 512 pulses/revolution (not for 1FK704) ¹⁾ Basic absolute encoder EnDat 32 pulses/rev. (only for 1FK704) ¹⁾ Multi-pole resolver 2-pole resolver				A E H G S T			
Encoder systems for motors with DRIVE-CLiQ interface ⁴⁾:		Incr. encoder sin/cos 1 V _{pp} 2048 pulses/rev. (not for 1FK701) Absolute encoder EnDat 2048 pulses/rev. (only for 1FK704) ¹⁾ Abs. encoder EnDat 512 pulses/rev. (not for 1FK701/1FK704) ¹⁾ Basic absolute encoder EnDat 32 pulses/rev. (only for 1FK704) ¹⁾ Multi-pole resolver (not for 1FK701) 2-pole resolver (not for 1FK701)				D F L K U P			
Shaft extension:		Radial eccentricity tolerance:		Holding brake:					
Fitted key and keyway		N		without					
Fitted key and keyway		N		with					
Plain shaft		N		without					
Plain shaft		N		with					
Degree of protection:		IP64, without paint finish IP64, anthracite paint finish (IP54 for 1FK701)						0 3	

To select the degree of protection and type, see "Selection guide".

Selection and ordering data

Motor type (continued)	Static current I_0 at M_0 $\Delta T=100$ K A	Calculated power $P_{calc} = M_0 \times$ $n_{rated}/9550$ P_{calc} for M_0 $\Delta T=100$ K kW/HP	SINAMICS Power Module		Power cable with complete shield Motor terminal (and brake terminal) via power connector		
			Rated output current I_{rated} at M_0 $\Delta T=100$ K A	Order No. For complete order no., see "SINAMICS S120"	Power con- nector Size	Motor cable cross section ³⁾ mm ²	Order no. Pre-assembled cable
1FK7032-5AF21...	1.7	0.36/0.5	2.3	6SL3210 - 1SB12-3UA0	1	4 x 1.5	6FX002-5A01-....
1FK7033-7AF21...	2.2	0.41/0.6	2.3	6SL3210 - 1SB12-3UA0	1	4 x 1.5	6FX002-5A01-....
1FK7034-5AF21...	1.9	0.5/0.7	2.3	6SL3210 - 1SB12-3UA0	1	4 x 1.5	6FX002-5A01-....
1FK7042-5AF21...	3.9	0.94/1.3	3.9	6SL3210 - 1SB14-0UA0	1	4 x 1.5	6FX002-5A01-....
1FK7043-7AF21...	3.9	0.85/1.1	3.9	6SL3210 - 1SB14-0UA0	1	4 x 1.5	6FX002-5A01-....
1FK7011-5AK21...	0.85	0.11/0.2	0.9	6SL3210 - 1SB11-0UA0	0.5	4 x 1.5	6FX5002-5ME00-.... ²⁾
1FK7015-5AK21...	0.85	0.22/0.3	0.9	6SL3210 - 1SB11-0UA0	0.5	4 x 1.5	6FX5002-5ME00-.... ²⁾
1FK7022-5AK21...	1.8	0.53/0.7	2.3	6SL3210 - 1SB12-3UA0	1	4 x 1.5	6FX002-5A01-....

Cooling:

Internal air cooling

0

Motor Module:

Single Motor Module

1

Power cable model:

MOTION-CONNECT 800
MOTION-CONNECT 500

8
5

Without brake cores

With brake cores

C
D

For length code as well as power and signal cables, see "MOTION-CONNECT cables and connections".

....

1) If the absolute encoder is used, M_{rated} is reduced by 10%.
 2) This power cable is fitted with a connector with M17 thread at the motor end and brake cores as standard (4 x 1.5 mm² + 2 x 1.5 mm²).
 3) The current carrying capacity of the power cable corresponds to IEC 60204-1 for type of routing C under continuous operating conditions with an ambient air temperature of +40 °C (104 °F), designed for I_0 (100 K), PVC/PUR-insulated cable.

4) Motors in shaft height 20 are not available with a DRIVE-CLiQ interface. The encoder systems are connected via the SMC (Sensor Module Cabinet-Mounted).

AC motors

Gearboxes

Series SP+ planetary gearbox for 1FT6 motors with natural cooling

Overview

1FT6 motors can be combined with planetary gearboxes to form compact coaxial drive units. The gearboxes are flanged directly to the drive end of the motors.

When selecting the gearbox, ensure that its rated speed is not exceeded by the maximum speed of the motor. In the case of high operating frequencies, allowance must be made for the shock factor f_2 (see Planning Guide "General Section for Synchronous Motors"). The frictional losses of the gearbox must always be taken into account.

The gearboxes are only available in non-balanced design.

Benefits

- High efficiency, single-stage: >97%, two-stage: >94%
- Minimum torsional backlash single-stage: ≤ 4 arcmin, two-stage: ≤ 6 arcmin
- Power transmission from the central sun gear to the planetary gears
- No shaft deflections in the planetary gear set due to the symmetrical force distribution
- Very low moment of inertia and short acceleration times
- Output shaft bearings dimensioned for high lateral and axial loads with pre-loaded tapered-roller bearings
- The gearboxes are connected to the motor shaft via an integrated clamping hub. A plain motor shaft end is necessary in this configuration. Radial eccentricity tolerance N in accordance with IEC 60072 and vibration severity grade N in accordance with IEC 60034-14 are sufficient.
- Output shaft of gearbox exactly coaxial with the motor
- The gearboxes are enclosed (seal between gearbox and motor) and filled with oil at the factory. They are lubricated and sealed for their service life. Gearboxes of frame sizes SP 060S to SP 180S are suitable for all mounting positions. The oil filling quantity for gearboxes of frame sizes SP 210 and SP 240 depends on the mounting position. The mounting position has to be specified when ordering.
- Gearbox degree of protection: IP65 (IP64 for frame sizes SP 210/SP 240)
- Small dimensions
- Low weight



Synchronous motor with mounted planetary gearbox

Integration

1FT602 and 1FT613 motors can be supplied ex factory (Siemens AG) complete with flange-mounted planetary gearbox.

The gearboxes assigned to the individual motors and gear ratios i available for these motor/gearbox combinations are listed in the selection table. When making a selection, the maximum permissible input speed of the gearbox (this is the same as the maximum motor speed) must be taken into consideration.

The motor/gearbox combinations listed in the selection tables are mainly intended for cycle operation S3-60% (ON time $\leq 60\%$ and ≤ 20 min). Reduced maximum motor speeds and output torques apply for use in S1 continuous duty (ON time $>60\%$ or >20 min). It is not permissible to exceed a gearbox temperature of $+90$ °C (194 °F).

Follow the instructions contained in the Planning Guide "General Section for Synchronous Motors" when assigning gearboxes to the motor.

1FT6 motors must be designed with plain motor shaft end/radial eccentricity tolerance N and vibration severity grade N/degree of protection IP65 (with 1FT602: IP64) for mounting onto the gearbox.

Selection and ordering data

Motor Type	Planetary gearbox single-stage		Weight of gearbox, approx. kg/lb	Available gear ratio <i>i</i>				Max. perm. motor speed S3-60% n_{G1} (n_1) rpm	Max. perm. output torque S3-60% M_{G2} (T_{2B}) Nm/lb _f -ft	Max. perm. radial output shaft load ³⁾ F_r (F_{2Rmax}) N/lb _f	Max. perm. axial output shaft load ³⁾ F_a (F_{2Amax}) N/lb _f
	Type	Tor- sional back- lash arcmin		4	5	7	10				
1FT6021 1FT6024 1FT6031 1FT6034	SP 060S-MF1	≤4	1.9/4.2	- ✓ ✓ ✓	- ✓ ✓ ✓	- ✓ ✓ ✓	✓ ✓ ✓ -	6000	40/29.5 (32/23.6 for $i = 10$)	2700/ 606.99	2400/ 539.54
1FT6034 1FT6041 1FT6044	SP 075S-MF1	≤4	3.9/8.6	- ✓ ✓	- ✓ ✓	- ✓ ✓	✓ ✓ ✓	6000	110/81.1 (90/66.3 for $i = 10$)	4000/ 899.24	3350/ 753.11
1FT6061 1FT6062 1FT6064	SP 100S-MF1	≤3	7.7/17.0	✓ ✓ ✓	✓ ✓ ✓	✓ ✓ ✓	✓ ✓ ✓	4500	300/221.3 (225/165.8 for $i = 10$)	6300/ 1416.30	5650/ 1270.18
1FT6081 1FT6082 1FT6084 1FT6086	SP 140S-MF1	≤3	17.2/37.9	✓ ✓ ✓ ✓	✓ ✓ ✓ ✓	✓ ✓ ✓ ✓	✓ ✓ ✓ -	4000	600/442.2 (480/353.8 for $i = 10$)	9450/ 2124.45	9870/ 2218.87
1FT6086 1FT6102 1FT6105 1FT6108	SP 180S-MF1	≤3	34/75.0	- ✓ ✓ ✓	- ✓ ✓ ✓	- ✓ ✓ ✓	✓ ✓ - -	3500	1100/810.7 (880/649.1 for $i = 10$)	14700/ 3304.71	14150/ 3181.06
1FT6105 1FT6108 1FT6132 1FT6134 1FT6136	SP 210-MF1 ²⁾	≤4	53/116.9	- - ✓ ✓ ✓	- - ✓ ✓ ✓	- - ✓ ✓ ✓	✓ ✓ ✓ - -	2500	1900/1400.3 (1520/1120.2 for $i = 10$)	18000/ 4046.58	22500/ 5058.23
1FT6134 1FT6136	SP 240-MF1 ²⁾	≤4	80/176.4	- -	- -	- -	✓ ✓	2200	2720/2004.6	27000/ 6069.87	27800/ 6249.72

Order codes

Gearbox shaft with fitted key

J02 J03 J05 J09

Gearbox shaft without fitted key

J22 J23 J25 J29

Ordering data **1FT6...-...71-..■1-Z**
J■ ■

Order No. of the motor with identifier “-Z” and
order code for mounting the planetary gearbox assigned to the motor
Prerequisite when mounting planetary gearboxes:
Plain motor shaft end/radial eccentricity tolerance N and vibration severity grade N/
IP65 degree of protection¹⁾

G w/o holding brake
H with holding brake

¹⁾ IP64 degree of protection with 1FT602.: **1FT602.-6AK71-..■0-Z J..**
G w/o holding brake
H with holding brake

²⁾ With these versions, the oil filling quantities depend on the mounting position. In the case of a vertical mounting position, the 12th position in the Order No. should be “9” and a further order code also has to be specified: **1FT6...-...79-..■1-Z J.. + M1 ■**

³⁾ In reference to the motor shaft center.

H mounting position IM V1
G mounting position IM V3

AC motors

Gearboxes

Series SP+ planetary gearbox, single-stage for 1FT6 motors

Technical data

Planetary gearbox with 1FT6 motor										
single-stage Type	Gear ratio	Motor speed		Output torque		Moments of inertia of gearbox (referred to the motor)				
		Continuous duty S1 ¹⁾		1FT602.	1FT603.	1FT604.	1FT606.	1FT608.	1FT610.	1FT613.
		n_{N1} rpm	M_{N2} (T_{2N}) Nm/ lb _f -ft	J_1 kgcm ² / lb _f -in-s ²	J_1 kgcm ² / lb _f -in-s ²	J_1 kgcm ² / lb _f -in-s ²	J_1 kgcm ² / lb _f -in-s ²	J_1 kgcm ² / lb _f -in-s ²	J_1 kgcm ² / lb _f -in-s ²	J_1 kgcm ² / lb _f -in-s ²
SP 060S-MF1	4	3300	26/19.2	0.16/0.00014	0.24/0.00021	–	–	–	–	–
	5	3300	26/19.2	0.13/0.00012	0.22/0.00019	–	–	–	–	–
	7	4000	26/19.2	0.11/0.00010	0.19/0.00017	–	–	–	–	–
	10	4000	17/12.5	0.10/0.00009	0.18/0.00016	–	–	–	–	–
SP 075S-MF1	4	2900	75/55.3	–	0.69/0.00061	0.94/0.00083	–	–	–	–
	5	2900	75/55.3	–	0.58/0.00051	0.83/0.00073	–	–	–	–
	7	3100	75/55.3	–	0.48/0.00042	0.73/0.00065	–	–	–	–
	10	3100	52/38.3	–	0.42/0.00037	0.67/0.00059	–	–	–	–
SP 100S-MF1	4	2500	180/132.7	–	–	–	3.65/0.00323	–	–	–
	5	2500	175/129	–	–	–	2.99/0.00265	–	–	–
	7	2800	170/125.3	–	–	–	2.81/0.00249	–	–	–
	10	2800	120/88.4	–	–	–	2.58/0.00228	–	–	–
SP 140S-MF1	4	2100	360/265.3	–	–	–	–	14.26/0.01262	–	–
	5	2100	360/265.3	–	–	–	–	13.06/0.01156	–	–
	7	2600	360/265.3	–	–	–	–	11.97/0.01059	–	–
	10	2600	220/162.1	–	–	–	–	11.39/0.01008	–	–
SP 180S-MF1	4	1500	750/552.8	–	–	–	–	45.08/0.03990	45.08/0.03990	–
	5	1500	750/552.8	–	–	–	–	36.37/0.03219	36.37/0.03219	–
	7	2300	750/552.8	–	–	–	–	28.57/0.02528	28.57/0.02528	–
	10	2300	750/552.8	–	–	–	–	24.40/0.02159	24.40/0.02159	–
SP 210-MF1	4	1200	1000/737	–	–	–	–	–	75.80/0.06708	75.80/0.06708
	5	1200	1000/737	–	–	–	–	–	63.50/0.05620	63.50/0.05620
	7	1700	1000/737	–	–	–	–	–	52.90/0.04682	52.90/0.04682
	10	1700	1000/737	–	–	–	–	–	47.10/0.04168	47.10/0.04168
SP 240-MF1	4	1000	1700/1252.9	–	–	–	–	–	–	146.30/0.12947
	5	1000	1700/1252.9	–	–	–	–	–	–	119.90/0.10611
	7	1500	1700/1252.9	–	–	–	–	–	–	96.40/0.08531
	10	1500	1700/1252.9	–	–	–	–	–	–	83.10/0.07354

¹⁾ The limit values in the table apply for S1 continuous duty (ON time >60% or >20 min) for a maximum gearbox temperature of +90 °C (194 °F)

Selection and ordering data

Motor Type	Planetary gearbox two-stage		Weight of gearbox, approx. kg/lb	Available gear ratio <i>i</i>					Max. perm. motor speed S3-60% n_{G1} (n_1) rpm	Max. perm. output torque S3-60% M_{G2} (T_{2B}) Nm/lb _f -ft	Max. perm. radial output shaft load ³⁾ F_r (F_{2Rmax}) N/lb _f	Max. perm. axial output shaft load ³⁾ F_a (F_{2Amax}) N/lb _f
	Type	Tor- sional back- lash arcmin		16	20	28	40	50				
1FT6021 1FT6024 1FT6031	SP 060S-MF2	≤6	2/4.4	✓	✓	✓	✓	✓	6000	40/29.5	2700/ 606.99	2400/ 539.54
1FT6024 1FT6031 1FT6034 1FT6041	SP 075S-MF2	≤6	3.6/7.9	-	-	-	-	✓	6000	110/81.1	4000/ 899.24	3350/ 753.11
1FT6034 1FT6041 1FT6044 1FT6061 1FT6062 1FT6064	SP 100S-MF2	≤5	7.9/17.4	-	-	-	✓	✓	4500	300/221.1	6300/ 1416.30	5650/ 1270.18
1FT6044 1FT6061 1FT6062 1FT6064 1FT6081 1FT6082 1FT6084	SP 140S-MF2	≤5	17/37.5	-	-	-	✓	✓	4000	600/442.2	9450/ 2124.45	9870/ 2218.87
1FT6064 1FT6081 1FT6082 1FT6084 1FT6086 1FT6102	SP 180S-MF2	≤5	36.4/80.3	-	-	-	✓	✓	4000	1100/810.7	14700/ 3304.71	14150/ 3181.06
1FT6082 1FT6105	SP 210-MF2 ²⁾	≤6	50/110.3	-	-	-	-	✓	3500	1900/1400.3	18000/ 4046.58	22500/ 5058.23
1FT6084 1FT6086 1FT6102 1FT6105 1FT6108 1FT6132 1FT6134 1FT6136	SP 240-MF2 ²⁾	≤6	70/154.4	-	-	-	✓	✓	3500	3400/2505.8	27000/ 6069.87	27800/ 6249.72

Order codes

Gearbox shaft with fitted key **J12** **J13** **J15** **J16** **J17**
 Gearbox shaft without fitted key **J32** **J33** **J35** **J36** **J37**

Ordering data **1FT6...-...71-...-1-Z**
J ■ ■

G w/o holding brake
H with holding brake

Order No. of the motor with identifier “-Z” and
 order code for mounting the planetary gearbox assigned to the motor.
 Prerequisite when mounting planetary gearboxes:
 Plain motor shaft end/radial eccentricity tolerance N and vibration severity grade N/
 IP65 degree of protection ¹⁾

¹⁾ IP64 degree of protection with 1FT602.: **1FT602.-6AK71-...-1-Z** **J..**

G w/o holding brake
H with holding brake

²⁾ With these versions, the oil filling quantities depend on the mounting position. In the case of a vertical mounting position, the 12th position in the
 Order No. should be “9” and a further order code also has to be specified: **1FT6...-...79-...-1-Z** **J.. + M1 ■**

³⁾ In reference to the motor shaft center.

H mounting position IM V1
G mounting position IM V3

AC motors

Gearboxes

Series SP+ planetary gearbox, two-stage for 1FT6 motors

Technical data

Planetary gearbox with 1FT6 motor												
two-stage Type	Gear ratio	Motor speed	Output torque	Moments of inertia of gearbox (referred to the motor)								
				Continuous duty S1 ¹⁾		1FT602.	1FT603.	1FT604.	1FT606.	1FT608.	1FT610.	1FT613.
				n_{N1} rpm	$M_{N2} (T_{2N})$ Nm/ lb _f -ft	J_1 kgcm ² / lb _f -in-s ²	J_1 kgcm ² / lb _f -in-s ²	J_1 kgcm ² / lb _f -in-s ²	J_1 kgcm ² / lb _f -in-s ²	J_1 kgcm ² / lb _f -in-s ²	J_1 kgcm ² / lb _f -in-s ²	J_1 kgcm ² / lb _f -in-s ²
SP 060S-MF2	16	4400	26/19.2	0.08/0.00007	0.18/0.00016	–	–	–	–	–		
	20	4400	26/19.2	0.07/0.00006	0.17/0.00015	–	–	–	–	–		
	28	4400	26/19.2	0.06/0.00005	0.16/0.00014	–	–	–	–	–		
	40	4400	26/19.2	0.06/0.00005	0.16/0.00014	–	–	–	–	–		
	50	4800	26/19.2	0.06/0.00005	0.16/0.00014	–	–	–	–	–		
SP 075S-MF2	16	3500	75/55.3	0.17/0.00015	0.25/0.00022	0.68 (0.00060)	–	–	–	–		
	20	3500	75/55.3	0.14/0.00012	0.22/0.00019	0.65 (0.00058)	–	–	–	–		
	28	3500	75/55.3	0.11/0.00010	0.19/0.00017	0.62 (0.00055)	–	–	–	–		
	40	3500	75/55.3	0.10/0.00009	0.18/0.00016	0.61 (0.00054)	–	–	–	–		
	50	3800	75/55.3	0.10/0.00009	0.18/0.00018	0.61 (0.00054)	–	–	–	–		
SP 100S-MF2	16	3100	180/132.7	–	0.72/0.00064	0.96 (0.00085)	2.80 (0.00230)	–	–	–		
	20	3100	180/132.7	–	0.60/0.00053	0.84 (0.00074)	2.48 (0.00219)	–	–	–		
	28	3100	180/132.7	–	0.49/0.00043	0.73 (0.00065)	2.36 (0.00209)	–	–	–		
	40	3100	180/132.7	–	0.43/0.00038	0.67 (0.00059)	2.31 (0.00204)	–	–	–		
	50	3500	175/129	–	0.43/0.00038	0.66 (0.00058)	2.30 (0.00204)	–	–	–		
SP 140S-MF2	16	2900	360/265.3	–	–	2.79 (0.00247)	3.61 (0.00319)	9.60/0.00850	–	–		
	20	2900	360/265.3	–	–	2.28 (0.00200)	3.08 (0.00273)	9.07/0.00803	–	–		
	28	2900	360/265.3	–	–	1.84 (0.00163)	2.86 (0.00235)	8.65/0.00766	–	–		
	40	2900	360/265.3	–	–	1.58 (0.00140)	2.39 (0.00212)	8.39/0.00743	–	–		
	50	3200	360/265.3	–	–	1.57 (0.00139)	2.38 (0.00211)	8.37/0.00741	–	–		
SP 180S-MF2	16	2700	750/552.8	–	–	–	10.24 (0.00906)	15.83/0.01401	14.36/0.01271	–		
	20	2700	750/552.8	–	–	–	8.48 (0.00750)	14.08/0.01246	12.06/0.01067	–		
	28	2700	750/552.8	–	–	–	6.90 (0.00611)	12.49/0.01105	11.02/0.00975	–		
	40	2700	750/552.8	–	–	–	6.06 (0.00536)	11.65/0.01031	10.17/0.00900	–		
	50	2900	750/552.8	–	–	–	5.98 (0.00529)	11.58/0.01025	10.10/0.00894	–		
SP 210-MF2	16	2100	1000/737	–	–	–	–	36.30/0.03212	37.40/0.03310	–		
	20	2100	1000/737	–	–	–	–	34.50/0.03053	35.60/0.03151	–		
	28	2100	1000/737	–	–	–	–	32.30/0.02859	33.40/0.02956	–		
	40	2300	1000/737	–	–	–	–	23.10/0.02044	24.30/0.02151	–		
	50	2300	1000/737	–	–	–	–	21.90/0.01938	23.00/0.02053	–		
SP 240-MF2	16	1900	1700/1252.9	–	–	–	–	47.30/0.04186	48.40/0.04283	53.00/0.04690		
	20	1900	1700/1252.9	–	–	–	–	43.10/0.03814	44.20/0.03912	48.80/0.04319		
	28	1900	1700/1252.9	–	–	–	–	37.50/0.03319	38.60/0.03416	43.20/0.03823		
	40	2100	1700/1252.9	–	–	–	–	32.40/0.02867	33.60/0.02974	38.10/0.03372		
	50	2100	1700/1252.9	–	–	–	–	29.50/0.02611	30.60/0.02708	35.10/0.03106		

¹⁾ The limit values in the table apply for S1 continuous duty (ON time >60% or >20 min) for a maximum gearbox temperature of +90 °C (194 °F)

Overview

1FK7 motors can be combined with planetary gearboxes to form compact coaxial drive units. The gearboxes are flanged directly to the drive end of the motors.

When selecting the gearbox, ensure that its rated speed is not exceeded by the maximum speed of the motor. In the case of high operating frequencies, allowance must be made for the shock factor f_2 (see Planning Guide "General Section for Synchronous Motors"). The frictional losses of the gearbox must always be taken into account.

The gearboxes are only available in non-balanced design.

Benefits

- High efficiency, single-stage: >97%, two-stage: >94%
- Torsional backlash single-stage: ≤ 4 arcmin,
 two-stage: ≤ 6 arcmin
- Power transmission from the central sun gear to the planetary gears
- No shaft deflections in the planetary gear set due to the symmetrical force distribution
- Very low moment of inertia and short acceleration times
- Output shaft bearings dimensioned for high lateral and axial loads with pre-loaded tapered-roller bearings
- The gearboxes are connected to the motor shaft via an integrated clamping hub. A plain motor shaft end is necessary in this configuration. Radial eccentricity tolerance N in accordance with IEC 60072 and vibration severity grade N in accordance with DIN IEC 60034-14 are sufficient.
- Output shaft of gearbox exactly coaxial with the motor
- The gearboxes are enclosed (seal between gearbox and motor) and filled with oil at the factory. They are lubricated and sealed for their service life. Gearboxes of frame sizes SP 060S to SP 180S are suitable for all mounting positions. The oil filling quantity for gearboxes of frame sizes SP 210 and SP 240 depends on the mounting position. The mounting position has to be specified when ordering.
- Gearbox degree of protection: IP65 (IP64 for frame sizes SP 210/SP 240)
- Small dimensions
- Low weight



Synchronous motor with mounted planetary gearbox

Integration

1FK702 to 1FK710 naturally-cooled motors can be supplied ex factory (Siemens AG) complete with flange-mounted planetary gearbox.

The gearboxes assigned to the individual motors and gear ratios i available for these motor/gearbox combinations are listed in the selection table. When making a selection, the maximum permissible input speed of the gearbox (this is the same as the maximum motor speed) must be taken into account.

The motor/gearbox combinations listed in the selection tables are mainly intended for cycle operation S3-60% (ON time $\leq 60\%$ and ≤ 20 min). Reduced maximum motor speeds and output torques apply for use in S1 continuous duty (ON time $>60\%$ or >20 min). It is not permissible to exceed a gearbox temperature of $+90$ °C (194 °F).

Follow the instructions contained in the Planning Guide "General Section for Synchronous Motors" when assigning gearboxes to the motor.

1FK7 motors should be designed with plain motor shaft end/ radial eccentricity tolerance N, degree of protection IP65 and anthracite paint finish for mounting onto the gearbox.

AC motors

Gearboxes

Series SP+ planetary gearbox, single-stage for 1FK7 motors with natural cooling

Selection and ordering data

Motor Natural cooling	Planetary gearbox single-stage			Available gear ratio <i>i</i>				Max. perm. motor speed S3-60%	Max. perm. output torque S3-60%	Max. perm. radial output shaft load ¹⁾	Max. perm. axial output shaft load ¹⁾
				4	5	7	10				
Type	Type	Torsional backlash arcmin	Weight of gearbox, approx. kg/lb					n_{G1} (n_1) rpm	M_{G2} (T_{2B}) Nm/lb _f -ft	F_r (F_{2Rmax}) N/lb _f	F_a (F_{2Amax}) N/lb _f
1FK7022	SP 060S-MF1	≤4	1.9/4.2	✓	✓	✓	✓	6000	40/29.5 (32/23.6 for $i = 10$)	2700/ 606.99	2400/ 539.54
1FK7032				✓	✓	✓	✓				
1FK7033				✓	✓	✓	✓				
1FK7034				✓	✓	✓	✓				
1FK7040	SP 075S-MF1	≤4	3.9/8.6	✓	✓	✓	✓	6000	110/81.1 (90/66.3 for $i = 10$)	4000/ 899.24	3350/ 753.11
1FK7042				✓	✓	✓	✓				
1FK7043				✓	✓	✓	✓				
1FK7044				✓	✓	✓	✓				
1FK7060	SP 100S-MF1	≤3	7.7/17.0	✓	✓	✓	✓	4500	300/221.1 (225/165.8 for $i = 10$)	6300/ 1416.30	5650/ 1270.18
1FK7061				✓	✓	✓	✓				
1FK7063				✓	✓	✓	✓				
1FK7064				✓	✓	✓	✓				
1FK7080	SP 140S-MF1	≤3	17.2/37.9	✓	✓	✓	✓	4000	600/442.2 (480/353.8 for $i = 10$)	9450/ 2124.45	9870/ 2218.87
1FK7082				✓	✓	✓	✓				
1FK7083				✓	✓	✓	✓				
1FK7085				✓	✓	✓	✓				
1FK7086				✓	✓	✓	✓				
1FK7100	SP 180S-MF1	≤3	34/75.0	✓	✓	✓	✓	3500	1100/810.7	14700/ 3304.71	14150/ 3181.06
1FK7101				✓	✓	✓	✓				
1FK7103				✓	✓	✓	✓				
1FK7105				✓	✓	✓	–				
1FK7105	SP 210-MF1 ²⁾	≤4	53/116.9	–	–	–	✓	2200	2720/2004.6	18000/ 4046.58	22500/ 5058.23

Order codes

Gearbox shaft with fitted key

J02 **J03** **J05** **J09**

Gearbox shaft without fitted key

J22 **J23** **J25** **J29**

Ordering data **1FK7...-A.71-1..5-Z**

J **J**

G w/o holding brake
H with holding brake

Order No. of the motor with identifier “-Z” and order code for mounting the planetary gearbox assigned to the motor
Prerequisite for mounting planetary gearboxes:
Plain motor shaft end IP65 degree of protection, anthracite paint finish

¹⁾ In reference to the motor shaft center.

²⁾ With this version, the oil filling quantities depend on the mounting position. In the case of a vertical mounting position, the 12th position in the Order No. should be “9” and a further order code also has to be specified: **1FK7...-A.79-1..5-Z J.. + M1**

H mounting position IM V1
G mounting position IM V3

Technical data

Planetary gearbox with 1FK7 motor, natural cooling											
single-stage Type	Gear ratio	Motor speed	Output torque	Moments of inertia of gearbox (referred to the motor)							
				Continuous duty S1 ¹⁾		1FK702.	1FK703.	1FK704.	1FK706.	1FK708.	1FK710.
				n_{N1} rpm	$M_{N2} (T_{2N})$ Nm/ lb _f -ft	J_1 kgcm ² / lb _f -in-s ²	J_1 kgcm ² / lb _f -in-s ²	J_1 kgcm ² / lb _f -in-s ²	J_1 kgcm ² / lb _f -in-s ²	J_1 kgcm ² / lb _f -in-s ²	J_1 kgcm ² / lb _f -in-s ²
SP 060S-MF1	4	3300	26/19.2	0.16/0.00014	0.24/0.00021	–	–	–	–		
	5	3300	26/19.2	0.13/0.00012	0.22/0.00019	–	–	–	–		
	7	4000	26/19.2	0.11/0.00010	0.19/0.00017	–	–	–	–		
	10	4000	17/12.5	0.10/0.00009	0.18/0.00016	–	–	–	–		
SP 075S-MF1	4	2900	75/55.3	–	–	0.94/0.00083	–	–	–		
	5	2900	75/55.3	–	–	0.83/0.00073	–	–	–		
	7	3100	75/55.3	–	–	0.73/0.00065	–	–	–		
	10	3100	52/38.3	–	–	0.67/0.00059	–	–	–		
SP 100S-MF1	4	2500	180/132.7	–	–	–	3.65/0.00323	–	–		
	5	2500	175/129	–	–	–	2.99/0.00265	–	–		
	7	2800	170/125.3	–	–	–	2.81/0.00249	–	–		
	10	2800	120/88.4	–	–	–	2.58/0.00228	–	–		
SP 140S-MF1	4	2100	360/265.3	–	–	–	–	14.26/0.01262	–		
	5	2100	360/265.3	–	–	–	–	13.06/0.01156	–		
	7	2600	360/265.3	–	–	–	–	11.97/0.01059	–		
	10	2600	220/162.1	–	–	–	–	11.39/0.01008	–		
SP 180S-MF1	4	1500	750/552.8	–	–	–	–	–	45.08/0.03990		
	5	1500	750/552.8	–	–	–	–	–	36.37/0.03219		
	7	2300	750/552.8	–	–	–	–	–	28.57/0.02528		
	10	2300	750/552.8	–	–	–	–	–	24.40/0.02159		
SP 210-MF1	4	1200	1000/737	–	–	–	–	–	75.80/0.06708		
	5	1200	1000/737	–	–	–	–	–	63.50/0.05620		
	7	1700	1000/737	–	–	–	–	–	52.90/0.04682		
	10	1700	1000/737	–	–	–	–	–	47.10/0.04168		
SP 240-MF1	4	1000	1700/1252.9	–	–	–	–	–	–		
	5	1000	1700/1252.9	–	–	–	–	–	–		
	7	1500	1700/1252.9	–	–	–	–	–	–		
	10	1500	1700/1252.9	–	–	–	–	–	–		

¹⁾ The limit values in the table apply for S1 continuous duty (ON time >60% or >20 min) for a maximum gearbox temperature of +90 °C (194 °F)

AC motors

Gearboxes

Series SP+ planetary gearbox, two-stage for 1FK7 motors with natural cooling

Selection and ordering data

Motor Natural cooling Type	Planetary gearbox two-stage		Weight of gearbox, approx. kg/lb	Available gear ratio <i>i</i>					Max. perm. motor speed S3-60% n_{G1} (n_1) rpm	Max. perm. output torque S3-60% M_{G2} (T_{2B}) Nm/lb _f -ft	Max. perm. radial output shaft load ¹⁾ F_r (F_{2Rmax}) N/lb _f	Max. perm. axial output shaft load ¹⁾ F_a (F_{2Amax}) N/lb _f
	Type	Torsional back-lash arcmin		16	20	28	40	50				
1FK7022	SP 060S-MF2	≤6	2/4.4	✓	✓	✓	-	-	6000	40/29.5	2700/ 606.99	2400/ 539.54
1FK7032				✓	✓	-	-	-				
1FK7033				✓	✓	-	-	-				
1FK7022	SP 075S-MF2	≤6	3.6/7.9	-	-	-	✓	✓	6000	110/81.1	4000/ 899.24	3350/ 753.11
1FK7032				-	-	✓	✓	✓				
1FK7033				-	-	✓	✓	✓				
1FK7034				-	-	✓	✓	✓				
1FK7040				✓	✓	✓	-	-				
1FK7042				✓	✓	✓	-	-				
1FK7043	✓	-	-	-	-							
1FK7040	SP 100S-MF2	≤5	7.9/17.4	-	-	-	✓	✓	4500	300/221.1	6300/ 1416.30	5650/ 1270.18
1FK7042				-	-	✓	✓	✓				
1FK7043				-	-	✓	✓	✓				
1FK7044				✓	✓	✓	✓	-				
1FK7060				✓	✓	✓	-	-				
1FK7061	✓	-	-	-	-							
1FK7044	SP 140S-MF2	≤5	17/37.5	-	-	-	-	✓	4000	600/442.2	9450/ 2124.45	9870/ 2218.87
1FK7060				-	-	✓	✓	✓				
1FK7061				-	-	✓	✓	✓				
1FK7063				✓	✓	✓	-	-				
1FK7064				✓	✓	✓	-	-				
1FK7080				✓	✓	✓	✓	-				
1FK7082				✓	✓	✓	-	-				
1FK7083				✓	✓	✓	-	-				
1FK7063	SP 180S-MF2	≤5	36.4/ 80.3	-	-	-	✓	✓	4000	1100/810.7	14700/ 3304.71	14150/ 3181.06
1FK7064				-	-	✓	✓	✓				
1FK7080				-	-	✓	✓	✓				
1FK7082				-	-	✓	✓	-				
1FK7083				-	-	✓	✓	-				
1FK7085				✓	✓	-	-	-				
1FK7086				✓	✓	-	-	-				
1FK7100				✓	✓	✓	-	-				
1FK7101	✓	✓	✓	-	-							
1FK7103	✓	-	-	-	-							
1FK7082	SP 210-MF2 ²⁾	≤6	50/ 110.3	-	-	-	-	✓	3500	1900/1400.3	18000/ 4046.58	22500/ 5058.23
1FK7083				-	-	✓	✓	✓				
1FK7085				-	-	✓	✓	✓				
1FK7086				-	-	✓	✓	-				
1FK7100				-	-	✓	✓	✓				
1FK7101				-	-	✓	✓	-				
1FK7103	-	✓	✓	-	-							
1FK7105	✓	✓	-	-	-							
1FK7101	SP 240-MF2 ²⁾	≤6	70/ 154.4	-	-	-	✓	✓	3500	3400/2505.8	27000/ 6069.87	27800/ 6249.72
1FK7103				-	-	✓	✓	-				
1FK7105				-	-	✓	-	-				

Order codes

Gearbox shaft with fitted key

J12 J13 J15 J16 J17

Gearbox shaft without fitted key

J32 J33 J35 J36 J37

Ordering data **1FK7...-A.71-1..-Z**

J ■ ■

G w/o holding brake
H with holding brake

Order No. of the motor with identifier “-Z” and order code for mounting the planetary gearbox assigned to the motor.

Plain motor shaft end/radial eccentricity tolerance N and vibration severity grade N/IP65 degree of protection

¹⁾ In reference to the motor shaft center.

²⁾ With this version, the oil filling quantities depend on the mounting position. In the case of a vertical mounting position, the 12th position in the Order No. should be “9” and a further order code also has to be specified: **1FK7...-A.79-1..-Z J.. + M1 ■**

H mounting position IM V1
G mounting position IM V3

Technical data

Planetary gearbox with 1FK7 motor, natural cooling											
two-stage Type	Gear ratio	Motor speed	Output torque	Moments of inertia of gearbox (referred to the motor)							
				Continuous duty S1 ¹⁾		1FK702.	1FK703.	1FK704.	1FK706.	1FK708.	1FK710.
				η_{N1} rpm	$M_{N2} (T_{2N})$ Nm/ lb _f -ft	J_1 kgcm ² / lb _f -in-s ²	J_1 kgcm ² / lb _f -in-s ²	J_1 kgcm ² / lb _f -in-s ²	J_1 kgcm ² / lb _f -in-s ²	J_1 kgcm ² / lb _f -in-s ²	J_1 kgcm ² / lb _f -in-s ²
SP 060S-MF2	16	4400	26/19.2	0.08/0.00007	0.18/0.00016	–	–	–	–		
	20	4400	26/19.2	0.07/0.00006	0.17/0.00015	–	–	–	–		
	28	4400	26/19.2	0.06/0.00005	0.16/0.00014	–	–	–	–		
	40	4400	26/19.2	0.06/0.00005	0.16/0.00014	–	–	–	–		
	50	4800	26/19.2	0.06/0.00005	0.16/0.00014	–	–	–	–		
SP 075S-MF2	16	3500	75/55.3	0.17/0.00015	0.25/0.00022	0.68/0.00060	–	–	–		
	20	3500	75/55.3	0.14/0.00012	0.22/0.00019	0.65/0.00058	–	–	–		
	28	3500	75/55.3	0.11/0.00010	0.19/0.00017	0.62/0.00055	–	–	–		
	40	3500	75/55.3	0.10/0.00009	0.18/0.00016	0.61/0.00054	–	–	–		
	50	3800	75/55.3	0.10/0.00009	0.18/0.00016	0.61/0.00054	–	–	–		
SP 100S-MF2	16	3100	180/132.7	–	–	0.96/0.00085	2.60/0.00230	–	–		
	20	3100	180/132.7	–	–	0.84/0.00074	2.48/0.00219	–	–		
	28	3100	180/132.7	–	–	0.73/0.00065	2.36/0.00209	–	–		
	40	3100	180/132.7	–	–	0.67/0.00059	2.31/0.00204	–	–		
	50	3500	175/129	–	–	0.66/0.00058	2.30/0.00204	–	–		
SP 140S-MF2	16	2900	360/265.3	–	–	2.79/0.00247	3.61/0.00319	9.60/0.00850	–		
	20	2900	360/265.3	–	–	2.26/0.00200	3.08/0.00273	9.07/0.00803	–		
	28	2900	360/265.3	–	–	1.84/0.00163	2.66/0.00235	8.65/0.00766	–		
	40	2900	360/265.3	–	–	1.58/0.00140	2.39/0.00212	8.39/0.00743	–		
	50	3200	360/265.3	–	–	1.57/0.00139	2.38/0.00211	8.37/0.00741	–		
SP 180S-MF2	16	2700	750/552.8	–	–	–	10.24/0.00906	15.83/0.01401	14.36/0.01271		
	20	2700	750/552.8	–	–	–	8.48/0.00750	14.08/0.01246	12.06/0.01067		
	28	2700	750/552.8	–	–	–	6.90/0.00611	12.49/0.01105	11.02/0.00975		
	40	2700	750/552.8	–	–	–	6.06/0.00536	11.65/0.01031	10.17/0.00900		
	50	2900	750/552.8	–	–	–	5.98/0.00529	11.58/0.01025	10.10/0.00894		
SP 210-MF2	16	2100	1000/737	–	–	–	–	36.30/0.03212	37.40/0.03310		
	20	2100	1000/737	–	–	–	–	34.50/0.03053	35.60/0.03151		
	28	2100	1000/737	–	–	–	–	32.30/0.02859	33.40/0.02956		
	40	2300	1000/737	–	–	–	–	23.10/0.02044	24.30/0.02151		
	50	2300	1000/737	–	–	–	–	21.90/0.01938	23.00/0.02035		
SP 240-MF2	16	1900	1700/1252.9	–	–	–	–	–	48.40/0.04283		
	20	1900	1700/1252.9	–	–	–	–	–	44.20/0.03912		
	28	1900	1700/1252.9	–	–	–	–	–	38.60/0.03416		
	40	2100	1700/1252.9	–	–	–	–	–	33.60/0.02974		
	50	2100	1700/1252.9	–	–	–	–	–	30.60/0.02708		

¹⁾ The limit values in the table apply for S1 continuous duty (ON time >60% or >20 min) for a maximum gearbox temperature of +90 °C (194 °F).

AC motors

Gearboxes

Series LP+ planetary gearbox for 1FK7 motors with natural cooling

Overview

1FK7 motors can easily be combined with planetary gearboxes to form compact coaxial drive units. The gearboxes are flanged directly to the drive end of the motors.

When selecting the gearbox, ensure that its rated speed is not exceeded by the maximum speed of the motor. In the case of high operating frequencies, allowance must be made for the shock factor f_2 (see Planning Guide "General Section for Synchronous Motors"). The frictional losses of the gearbox must always be taken into account.

The gearboxes are only available in non-balanced design and with fitted key.

Benefits

- High efficiency, single-stage: >97%
- Torsional backlash, single-stage: ≤ 12 arcmin
- Power transmission from the central sun gear to the planetary gears
- No shaft deflections in the planetary gear set due to symmetrical force distribution
- The gearboxes are connected to the motor shaft via an integrated clamping hub. A plain motor shaft end is required in this configuration. Radial eccentricity tolerance N in accordance with IEC 60072 and vibration severity grade N in accordance with DIN IEC 60034-14 are sufficient.
- Output shaft of gearbox exactly coaxial with the motor
- The gearboxes are suitable for all mounting positions
- The gearboxes are sealed (seal between gearbox and motor) and filled with grease in the factory. They are lubricated and sealed for their service life
- Gearbox degree of protection: IP64
- The gearboxes are suitable for all mounting positions
- Small dimensions
- Low weight



Series LP+ planetary gearbox

Integration

1FK702 to 1FK710 motors can be supplied ex factory (Siemens AG) complete with flange-mounted planetary gearbox.

The gearboxes assigned to the individual motors and gear ratios i available for these motor/gearbox combinations are listed in the selection table. When making a selection, the maximum permissible input speed of the gearbox must be considered (the same as the maximum motor speed).

The motor/gearbox combinations listed in the selection table are mainly intended for cycle operation S3-60% (ON time $\leq 60\%$ and ≤ 20 min). Reduced maximum motor speeds and output torques apply for use in S1 continuous duty (ON time $>60\%$ or >20 min). The gearbox temperature may not exceed 90°C (194°F).

Follow the instructions contained in the Planning Guide "General Section for Synchronous Motors" when assigning gearboxes to the motor.

Selection and ordering data

Motor Natural cooling	Planetary gearbox single-stage		Available gear ratios <i>i</i>		Max. perm. input speed	Max. perm. output torque		Max. perm. radial force on output shaft ¹⁾	Moment of inertia of gearboxes
	Type	Type	Weight of gearbox, approx. kg/lb	5	10	n_{G1} rpm	M_{G2} at $i = 5$ Nm/lb _f -ft	M_{G2} at $i = 10$ Nm/lb _f -ft	F_r N/lb _f
1FK7022	LP 050-M01	0.75/1.65	✓	–	8000	12/8.8	10.5/7.7	650/146.13	0.055/0.00005
1FK7022	LP 070-M01	2.0/4.41	–	✓	6000	35/25.8	32/23.6	1450/325.97	0.28/0.0002
1FK7032			✓	✓					
1FK7033			✓	✓					
1FK7034			✓	✓					
1FK7040	LP 090-M01	4.0/8.82	✓	✓	6000	90/66.3	80/59	2400/539.54	1.77/0.0016
1FK7042			✓	✓					
1FK7043			✓	✓					
1FK7044			✓	✓					
1FK7060	LP 120-M01	8.6/18.96	✓	✓	4800	220/162.1	200/147.4	4600/1034.13	5.42/0.0048
1FK7061			✓	✓					
1FK7063			✓	✓					
1FK7064			✓	–					
1FK7080	LP 155-M01	17/37.49	✓	✓	3600	450/331.7	350/258	7500/1686.87	25.73/0.0228
1FK7082			✓	✓					
1FK7083			✓	✓					
1FK7085			✓	–					
1FK7086			✓	–					
1FK7100			✓	✓					
1FK7101			✓	–					
1FK7103			✓	–					
1FK7105	✓	–							

Order code

Gearbox shaft with fitted key

V40

V42

Ordering data **1FK7...-A.71-...3-Z**
V ■ ■

G w/o holding brake
H with holding brake

Order No. of the motor with identifier “-Z” and
order code for mounting the planetary gearbox assigned to the motor
Precondition:
Plain motor shaft end

Continuous duty S1

Continuous duty is permissible at rated speed and rated torque.
The gearbox temperature may not exceed 90 °C (194 °F).

Planetary gearbox single-stage	Rated input speed	Rated output torque	
Type	n_{N1} rpm	M_{N2} at $i = 5$ Nm/lb _f -ft	M_{N2} at $i = 10$ Nm/lb _f -ft
LP 050-M01	4000	5.7/4.2	–
LP 070-M01	3700	18/13.3	16.5/12.2
LP 090-M01	3400	45/33.2	40/29.5
LP 120-M01	2600	110/81.1	100/73.7
LP 155-M01	2000	320/235.8	190/140

¹⁾ Referred to the center of the output shaft at 100 rpm.

AC motors

Geared motors

1FK7-DYA compact geared motors

Overview



The 1FK7-DYA compact geared motor combines electrical and mechanical components in the smallest space possible. This mechatronic unit consists of a permanent-field 1FK7 series synchronous motor and a directly mounted single-stage planetary gear.

The 1FK7-DYA compact geared motors with degree of protection IP64 are designed for operation without external cooling as the heat is dissipated over the motor surface. The integrated planetary gearboxes have high maximum torques and permit high radial and axial forces at the shaft end.

Benefits

- Space-saving installation due to the high power density of the motor and integration of the planetary gearbox directly into the motor end shield. Mounting to the machine is greatly simplified by this
- Mounting in construction types IM B5 and IM B14 is possible
- High dynamics due to reduced inertial torque, allowing short cycle times to be achieved
- Maintenance-free
- Suited for S1 continuous duty
- High degree of positioning accuracy due to the low mechanical torsional backlash of less than 8 arcmin
- Mechanical compatibility with IM B14 flange and shaft end for the LP+ planetary gearbox
- Power connection via plug, signal connection via plug or DRIVE-CLiQ (for SINAMICS S120)

Applications

In general machine construction wherever coaxial drive units are used, such as in

- Packaging machines
- Wood, glass and ceramic processing machines
- Plastic, injection molding and foil stretching machines
- Handling systems
- Machine tools
- All kinds of auxiliary axes

Integration

Together with the SINAMICS S120, SIMOVERT MASTERDRIVES Motion Control or SIMODRIVE 611 universal HRS drive systems, the 1FK7-DYA compact geared motors form a powerful system with a high degree of functionality.

The integrated encoder system for speed and position control can be selected.

Technical data

Type of motor	Permanent-magnet synchronous motor
Magnet material	Rare-earth magnet material
Insulation of the stator winding in accordance with EN 60034-1 (IEC 60034-1)	Thermal Class F for a winding temperature rise of $\Delta T = 100 \text{ K}$ at an ambient temperature of 40 °C ($+104 \text{ °F}$)
Type in accordance with EN 60034-7 (IEC 60034-7)	IM B5 (IM V1, IM V3) IM B14
Degree of protection in accordance with EN 60034-5 (IEC 60034-5)	IP64
Cooling	Natural cooling
Temperature monitoring	KTY 84 temperature sensor in stator winding
Paint finish	Anthracite, color RAL 7016
Shaft end on the drive end in accordance with DIN 748-3 (IEC 60072-1)	with fitted key
2nd rating plate 3rd rating plate	Glued to the end shield Enclosed separately
Radial eccentricity, concentricity and axial eccentricity in accordance with DIN 42955 (IEC 60072-1)	Tolerance N (normal)
Vibration severity in accordance with EN 60034-14 (IEC 60034-14)	Grade N (normal)
Noise pressure level in accordance with DIN EN ISO 1680, max.	1FK703: 72 dB(A) 1FK704: 75 dB(A) 1FK706: 80 dB(A) 1FK708: 82 dB(A)
Encoder systems, built-in, for motors with/without DRIVE-CLiQ interface	<ul style="list-style-type: none"> • Incremental encoder sin/cos $1 V_{pp}$ 2048 pulses/revolution • Absolute encoder, multiturn, 2048 pulses/revolution with 1FK704. to 1FK708. or 512 pulses/revolution with 1FK703. and traversing range 4096 rev. with EnDat interface. • Basic absolute encoder, multi-turn, 32 pulses/revolution and traversing range 4096 revolutions with EnDat interface with 1FK704. to 1FK708.
Connection	Connectors for signals and power can be rotated (270°)
Options	Integrated holding brake

AC motors

Geared motors

1FK7-DYA compact geared motors

Selection and ordering data

Rated speed	Rated power	Maximum rotational speed	Maximum torque	Static torque	Rated torque	Available gear ratio	Compact geared motor	Order code	Number of pole pairs	Rotor moment of inertia (without brake)	Rotor moment of inertia (with brake)
n_{2N}	P_2	n_{2max}	M_{2max}	M_{20}	M_{2N}	i	Order No.			J	J
rpm	kW/HP	rpm	Nm/lb _f -ft	Nm/lb _f -ft	Nm/lb _f -ft					10 ⁻⁴ kgm ² / lb _f -in-s ²	10 ⁻⁴ kgm ² / lb _f -in-s ²
370	0.37/ 0.50	600	32/23.6	11/8.1	9.5/7	10	1FK7032-5AK71-1 ■ ■ 3-Z A03		3	0.75/ 0.0007	0.83/ 0.0007
740	0.5/ 0.67	1200	32/23.6	7.5/5.5	6.5/4.8	5	1FK7034-5AK71-1 ■ ■ 3-Z A00		3	1.04/ 0.0009	1.12/ 0.0010
340	0.45/ 0.60	600	49/36.1	15/11.1	12.5/9.2	10	1FK7040-5AK71-1 ■ ■ 3-Z A13		4	2.3/ 0.0020	3/ 0.0027
680	0.71/ 0.95	1200	51/37.6	13/9.6	10/7.4	5	1FK7042-5AK71-1 ■ ■ 3-Z A10		4	3.6/ 0.0032	4.3/ 0.0038
260	1.25/ 1.68	480	175/129	57/42	46/33.9	10	1FK7060-5AH71-1 ■ ■ 3-Z A73		4	10.3/ 0.0091	12.5/ 0.0111
520	1.74/ 2.33	960	170/125.3	51/37.6	32/23.6	5	1FK7063-5AH71-1 ■ ■ 3-Z A70		4	17.4/ 0.0154	19.6/ 0.0173
200	1.47/ 1.97	360	242/178.4	76/56	70/51.6	10	1FK7080-5AH71-1 ■ ■ 3-Z A83		4	28.7/ 0.0254	31.8/ 0.0281
400	1.88/ 2.52	720	233/171.7	68/50.1	45/33.2	5	1FK7083-5AH71-1 ■ ■ 3-Z A80		4	41/ 0.0363	49.6/ 0.0439
Encoder systems for motors without DRIVE-CLiQ interface:			Incremental encoder sin/cos 1 V _{pp} 2048 pulses/revolution Absolute encoder EnDat 2048 pulses/rev. ¹⁾ (not for 1FK703) Abs. encoder EnDat 512 pulses/rev. (not for 1FK704 to 1FK708) Basic absolute encoder 32 pulses/revolution (not for 1FK703) Multi-pole resolver 2-pole resolver				A E H G S T				
Encoder systems for motors with DRIVE-CLiQ interface:			Incremental encoder sin/cos 1 V _{pp} 2048 pulses/revolution Absolute encoder EnDat 2048 pulses/rev. ¹⁾ (not for 1FK703) Abs. encoder EnDat 512 pulses/rev. (not for 1FK704 to 1FK708) Basic absolute encoder 32 pulses/revolution (not for 1FK703) Multi-pole resolver 2-pole resolver				D F L K U P				
Shaft extension: Fitted key and keyway Fitted key and keyway			Radial eccentricity: Tolerance N Tolerance N		Holding brake: without with		U V				
Degree of protection:			IP64, color RAL 7016 (anthracite)						3		

Selection and ordering data

Motor type (continued)	Weight		Static current I_0 at M_0 $\Delta T = 100\text{ K}$ A	Maxi- mum current I_{max} A	SINAMICS Motor Module		Power cable with complete shield Motor terminal (and brake terminal) via power connector		
	(without brake) m kg/lb	(with brake) m kg/lb			Rated output current I_N A	Order No. For complete order no., see "SINAMICS S120"	Power con- nector Size	Motor cable cross section ²⁾ mm ²	Order no. Pre-assembled cable
1FK7032-5AK71-...	4.11/ 9.06	4.47/ 9.86	1.7	5	3	6SL312 - TE13-0AA0	1	4 x 1.5	6FX 002-5 S01 -....
1FK7034-5AK71-...	5.01/ 11.05	5.37/ 11.84	1.9	7.9	3	6SL312 - TE13-0AA0	1	4 x 1.5	6FX 002-5 S01 -....
1FK7040-5AK71-...	6.6/ 14.55	7.61/ 16.78	2.3	7.4	3	6SL312 - TE13-0AA0	1	4 x 1.5	6FX 002-5 S01 -....
1FK7042-5AK71-...	7.91/ 17.44	8.62/ 19.01	4.4	14.9	5	6SL312 - TE15-0AA0	1	4 x 1.5	6FX 002-5 S01 -....
1FK7060-5AH71-...	13.9/ 30.65	15/ 33.08	6.2	19	9	6SL312 - TE21-0AA0	1	4 x 1.5	6FX 002-5 S01 -....
1FK7063-5AH71-...	17.6/ 38.81	19/ 41.90	12	41	18	6SL312 - TE21-8AA0	1	4 x 1.5	6FX 002-5 S01 -....
1FK7080-5AH71-...	23.4/ 51.60	24.6/ 54.24	7.4	24	9	6SL312 - TE21-0AA0	1	4 x 1.5	6FX 002-5 S01 -....
1FK7083-5AH71-...	28.6/ 63.06	31.2/ 68.80	15	48	18	6SL312 - TE21-8AA0	1	4 x 1.5	6FX 002-5 S01 -....

Cooling:

Internal air cooling
External air cooling

0
1

Motor Module:

Single Motor Module
Double Motor Module

1
2

Power cable model:

MOTION-CONNECT 800
MOTION-CONNECT 500

8
5

Without brake cores
With brake cores

C
D

For length code as well as power and signal cables, see "MOTION-CONNECT cables and connections".

....

- ¹⁾ If the absolute encoder is used, M_{rated} is reduced by 10%.
- ²⁾ The current carrying capacity of the Motor Module corresponds to IEC 60204-1 for type of routing C under continuous operation conditions with an ambient air temperature of +40 °C (104 °F), designed for I_0 (100 K), PVC/PUR-insulated cable.

AC motors

Geared motors

1FK7 geared servomotors

Overview



1FK7 geared servomotors

The 1FK7 geared servomotors comprise of the 1FK7 synchronous motors described above and the directly mounted helical and bevel gears.

The 1FK7 geared servomotors are pre-assembled as a complete unit and supplied with a gearbox filled with oil. The range comprises of helical gear motors with 9 gearbox sizes, offset shaft geared motors with 5 gearbox sizes, bevel gear motors with 8 gearbox sizes and worm gear motors with 5 gearbox sizes. A wide range of mechanical mounting methods can be implemented with the numerous options.

1FK7 geared servomotors are designed for operation without external cooling as the heat is dissipated through the motor surface.

1FK7 geared servomotors can be combined with the SINAMICS S120 drive system to create a powerful system with high functionality. Integrated encoder systems for speed and position control can be selected, just as with 1FK7 synchronous motors.

Benefits

- Extremely compact design as a result of the direct mounting (no coupling cage between the motor and gearbox)
- Maintenance-free and lubricated for service life (exception, worm gearing)
- High efficiency
- Low torsional backlash
- Low running noise due to the helical teeth
- High endurance gearing (exception, worm gearing)
- Suitable for cyclic operation with alternating load and continuous duty
- Favorably-priced solution when compared to planetary geared motors

Applications

1FK7 geared servomotors are ideally suited for applications in general machine construction for basic positioning tasks and auxiliary drives with servo quality that continually operate, for example in:

- Packaging machines
- High-bay racking units
- Wood, glass and ceramic processing machines
- Beverage filling plants
- Conveyor belts

Technical data

Helical geared motor

Nominal ratio	$i_{nom} = 3.8$ to 70
Rated output torque	$M_2 = 46$ Nm to 1370 Nm/ 33.9 lb _f -ft to 1009.7 lb _f -ft
Max. perm. acceleration torque	$M_{2max} = 65$ Nm to 4140 Nm/ 47.9 lb _f -ft to 3051.2 lb _f -ft
Torsional backlash	10 arcmin to 20 arcmin
Efficiency	94% to 96%
Mechanical options	Solid shaft with fitted key, flange, mounting feet, tapped hole group

Offset shaft geared motor

Nominal ratio	$i_{nom} = 4.3$ to 35
Rated output torque	$M_2 = 58$ Nm to 529 Nm/ 42.7 lb _f -ft to 389.9 lb _f -ft
Max. perm. acceleration torque	$M_{2max} = 120$ Nm to 1100 Nm/ 88.4 lb _f -ft to 810.7 lb _f -ft
Torsional backlash	10 arcmin to 11 arcmin
Efficiency	94% to 96%
Mechanical options	Solid shaft, hollow shaft with fitted key, hollow shaft with tensioning element/shrink disk, flange, mounting feet, tapped hole group

Bevel geared motor

Nominal ratio	$i_{nom} = 4$ to 76
Rated output torque	$M_2 = 89$ Nm to 1280 Nm/ 65.6 lb _f -ft to 943.4 lb _f -ft
Max. perm. acceleration torque	$M_{2max} = 135$ Nm to 4650 Nm/ 99.5 lb _f -ft to 3427.1 lb _f -ft
Torsional backlash	10 arcmin to 12 arcmin
Efficiency	94% to 96%
Mechanical options	Solid shaft, hollow shaft with fitted key, hollow shaft with tensioning element/shrink disk, flange, mounting feet, tapped hole group, torque bracket

Worm geared motor

Nominal ratio	$i_{nom} = 9.2$ to 70
Rated output torque	$M_2 = 80$ Nm to 430 Nm/ 59 lb _f -ft to 316.9 lb _f -ft
Max. perm. acceleration torque	$M_{2max} = 96$ Nm to 720 Nm/ 70.8 lb _f -ft to 530.6 lb _f -ft
Torsional backlash	Adjustable, ca. 13 arcmin on average
Mechanical options	Solid shaft, hollow shaft with fitted key, hollow shaft with tensioning element/shrink disk, flange, mounting feet, tapped hole group, torque bracket

The "CAD CREATOR" tool can be used to configure the geared servomotors and as a guide to selection and ordering. This tool contains the relevant data and all dimension drawings.

The order no. for the CD-ROM is **6SL3075-0AA00-0AG0**

"CAD CREATOR" can also be accessed on the internet website
www.siemens.com/cad-creator

Other Siemens geared motors can be found on the website:
www.siemens.com/sgmdesigner

Selection and ordering data

Explanation of the designations in the selection tables

P_2	kW/HP	Mechanical power output at the gearbox shaft (in S3 duty)
n_2	rpm	Gearbox output speed referred to the input speed of the motor of $n_1 = 3000$ rpm for a horizontal gearbox shaft output
M_2	Nm/lb _f -ft	Rated gearbox output torque in S3 duty
M_{2max}	Nm/lb _f -ft	Max. permissible acceleration torque of the gearbox
i_{nom}		Nominal gearbox ratio (approximate value as decimal number)
i_{exact}		Exact gearbox ratio (specified as a fraction for parameter entry in the drive converter)
F_{rperm}	N/lb _f	Max. perm. cantilever force on gear shaft end
f_B		Gearbox overload factor (quotient between the max. permissible acceleration torque and stall torque of the motor and ratio)
Gear unit size	C... F... K... S...	Identifier for gearbox type and size
SH		Motor frame size (1FK7 motors are available in frame sizes 36, 48, 63, 80 and 100)
Order codes		The order codes define the gearbox type, size, ratio and mechanical design
Weight	kg/lb	Total weight of the geared motor

AC motors

Geared motors

1FK7 geared servomotors Helical geared motors

Selection and ordering data

Output (S3 -60%)	Output speed	Rated output torque	Max. permissible acceleration torque	Nominal ratio	Exact ratio	Cantilever force gearbox shaft extension	Overload factor
P_2 kW/HP	n_2 rpm	M_2 Nm/lb _f -ft	M_{2max} Nm/lb _f -ft	i_{nom}	i_{exact}	F_{rperm} N/lb _f	f_B
0.30/0.40	782 476	3.63/2.7 5.96/4.4	19/14 29/21.4	3.8 6.3	441/115 2035/323	560/125.89 660/148.37	4.2 3.9
	291 192	9.74/7.2 14.8/10.9	51/37.6 72/53.1	10.5 15.5	1421/138 1595/102	778/174.90 894/200.98	4.2 3.9
	129 86	22/16.2 33.1/24.4	65/47.9 65/47.9	23 35	325/14 1261/36	1020/229.31 1170/263.03	2.4 1.6
	64 43	44.3/32.6 66.6/49.1	65/47.9 138/101.7	47 70	7865/168 775/11	1289/289.78 2099/471.88	1.2 1.7
	782 476	5.02/3.7 8.25/6.1	36/26.5 55/40.5	3.8 6.3	441/115 2035/323	560/125.89 660/148.37	6.0 5.6
0.41/0.55	291 192	13.5/9.9 20.5/15.1	72/53.1 72/53.1	10.5 15.5	1421/138 1595/102	778/174.90 894/200.98	4.5 3.0
	128 129	30.8/22.7 30.4/22.4	138/101.7 65/47.9	24 23	1035/44 325/14	1456/327.32 1020/229.31	3.8 1.8
	86 86	45.9/33.8 45.9/33.8	138/101.7 65/47.9	35 35	2700/77 1261/36	1663/373.86 1170/263.03	2.5 1.2
	64	61.4/45.3	138/101.7	47	516/11	1833/412.08	1.9
	782 476	9.67/7.1 15.9/11.7	36/26.5 55/40.5	3.8 6.3	441/115 2035/323	560/125.89 660/148.37	3.2 3.0
	291 191	26/19.2 39.6/29.2	72/53.1 138/101.7	10.5 15.5	1421/138 377/24	778/174.90 1273/286.18	2.4 3.0
0.79/1.06	192 128	39.4/29 59.3/43.7	72/53.1 138/101.7	15.5 24	1595/102 1035/44	894/200.98 1456/327.32	1.6 2.0
	86 64	88.4/65.2 118/87	138/101.7 138/101.7	35 47	2700/77 516/11	1663/373.86 1833/412.08	1.4 1.0
	782 476	17.5/12.9 28.7/21.2	50/36.9 59/43.5	3.8 6.3	441/115 2035/323	560/125.89 660/148.37	2.2 1.6
	511 291	26.8/19.8 46.9/34.6	102/75.2 72/53.1	5.9 10.5	47/8 1421/138	917/206.15 778/174.90	3.0 1.2
	289 191	47.3/34.9 71.6/52.8	138/101.7 138/101.7	10.5 15.5	841/81 377/24	1109/267.52 1273/286.18	2.3 1.5
1.43/1.92	196 128	69.7/51.4 107/78.9	230/169.5 138/101.7	15.5 25	703/46 1035/44	1775/399.04 1456/327.32	2.6 1.0
	128	107/78.9	350/258	24	845/36	3045/684.55	2.6
	142/1.90	85	160/117.9	230/169.5	35	1372/39	2343/526.73
1.43/1.92	86 60	159/117.2 227/167.3	550/405.4 400/294.8	35 50	975/28 2736/55	5961/1340.09 3911/879.23	2.7 1.4
	1.44/1.93	60 43	229/168.8 319/235.1	600/442.2 550/405.4	50 70	1305/26 559/8	6734/1513.87 7519/7690.35
43		319/235.1	850/626.5	70	10075/144	9229/2074.77	2.1

1FK7 geared servomotors Helical geared motors

Gearbox size	Motor frame size	Helical geared motors Order No.	Order codes			Total weight, approx. kg/lb
			Gearbox type	Type	Type of construction mounting position	
C002	36	1FK7032-5AK71-1 ■ ■ 5-Z	D01	G ■ ■	H ■ ■	8.6/19.0
C002	36	1FK7032-5AK71-1 ■ ■ 5-Z	D02	G ■ ■	H ■ ■	8.6/19.0
C002	36	1FK7032-5AK71-1 ■ ■ 5-Z	D03	G ■ ■	H ■ ■	8.6/19.0
C002	36	1FK7032-5AK71-1 ■ ■ 5-Z	D04	G ■ ■	H ■ ■	8.6/19.0
C002	36	1FK7032-5AK71-1 ■ ■ 5-Z	D05	G ■ ■	H ■ ■	8.6/19.0
C002	36	1FK7032-5AK71-1 ■ ■ 5-Z	D06	G ■ ■	H ■ ■	8.6/19.0
C002	36	1FK7032-5AK71-1 ■ ■ 5-Z	D07	G ■ ■	H ■ ■	8.6/19.0
C102	36	1FK7032-5AK71-1 ■ ■ 5-Z	D18	G ■ ■	H ■ ■	13.5/29.8
C002	48	1FK7040-5AK71-1 ■ ■ 5-Z	D01	G ■ ■	H ■ ■	9.4/20.7
C002	48	1FK7040-5AK71-1 ■ ■ 5-Z	D02	G ■ ■	H ■ ■	9.4/20.7
C002	48	1FK7040-5AK71-1 ■ ■ 5-Z	D03	G ■ ■	H ■ ■	9.4/20.7
C002	48	1FK7040-5AK71-1 ■ ■ 5-Z	D04	G ■ ■	H ■ ■	9.4/20.7
C102	48	1FK7040-5AK71-1 ■ ■ 5-Z	D15	G ■ ■	H ■ ■	14.3/31.5
C002	48	1FK7040-5AK71-1 ■ ■ 5-Z	D05	G ■ ■	H ■ ■	9.4/20.7
C102	48	1FK7040-5AK71-1 ■ ■ 5-Z	D16	G ■ ■	H ■ ■	14.3/31.5
C002	48	1FK7040-5AK71-1 ■ ■ 5-Z	D06	G ■ ■	H ■ ■	9.4/20.7
C102	48	1FK7040-5AK71-1 ■ ■ 5-Z	D17	G ■ ■	H ■ ■	14.3/31.5
C002	48	1FK7042-5AF71-1 ■ ■ 5-Z	D01	G ■ ■	H ■ ■	10.7/23.6
C002	48	1FK7042-5AF71-1 ■ ■ 5-Z	D02	G ■ ■	H ■ ■	10.7/23.6
C002	48	1FK7042-5AF71-1 ■ ■ 5-Z	D03	G ■ ■	H ■ ■	10.7/23.6
C102	48	1FK7042-5AF71-1 ■ ■ 5-Z	D14	G ■ ■	H ■ ■	15.6/34.4
C002	48	1FK7042-5AF71-1 ■ ■ 5-Z	D04	G ■ ■	H ■ ■	10.7/23.6
C102	48	1FK7042-5AF71-1 ■ ■ 5-Z	D15	G ■ ■	H ■ ■	15.6/34.4
C102	48	1FK7042-5AF71-1 ■ ■ 5-Z	D16	G ■ ■	H ■ ■	15.6/23.6
C102	48	1FK7042-5AF71-1 ■ ■ 5-Z	D17	G ■ ■	H ■ ■	15.6/23.6
C002	63	1FK7060-5AF71-1 ■ ■ 5-Z	D01	G ■ ■	H ■ ■	13.4/29.6
C002	63	1FK7060-5AF71-1 ■ ■ 5-Z	D02	G ■ ■	H ■ ■	13.4/29.6
C102	63	1FK7060-5AF71-1 ■ ■ 5-Z	D12	G ■ ■	H ■ ■	18.3/40.4
C002	63	1FK7060-5AF71-1 ■ ■ 5-Z	D03	G ■ ■	H ■ ■	13.4/29.6
C102	63	1FK7060-5AF71-1 ■ ■ 5-Z	D13	G ■ ■	H ■ ■	18.3/40.4
C102	63	1FK7060-5AF71-1 ■ ■ 5-Z	D14	G ■ ■	H ■ ■	18.3/40.4
C202	63	1FK7060-5AF71-1 ■ ■ 5-Z	D24	G ■ ■	H ■ ■	22.3/49.2
C102	63	1FK7060-5AF71-1 ■ ■ 5-Z	D15	G ■ ■	H ■ ■	18.3/40.4
C302	63	1FK7060-5AF71-1 ■ ■ 5-Z	D35	G ■ ■	H ■ ■	27.4/60.4
C202	63	1FK7060-5AF71-1 ■ ■ 5-Z	D26	G ■ ■	H ■ ■	22.3/49.2
C402	63	1FK7060-5AF71-1 ■ ■ 5-Z	D46	G ■ ■	H ■ ■	37.6/82.9
C302	63	1FK7060-5AF71-1 ■ ■ 5-Z	D37	G ■ ■	H ■ ■	27.4/60.4
C402	63	1FK7060-5AF71-1 ■ ■ 5-Z	D47	G ■ ■	H ■ ■	37.6/82.9
C402	63	1FK7060-5AF71-1 ■ ■ 5-Z	D48	G ■ ■	H ■ ■	37.6/82.9
C502	63	1FK7060-5AF71-1 ■ ■ 5-Z	D58	G ■ ■	H ■ ■	49.2/108.5

Encoder systems: Motors without DRIVE-CLiQ interface	Incremental encoder sin/cos 1 V _{pp}	A
	Absolute encoder EnDat 2048 pulses/rev. (shaft height 48 and higher)	E
	Absolute encoder EnDat 512 pulses/rev. (only shaft height 36)	H
	Basic abs. encoder EnDat 32 pulses/rev. (shaft height 48 and higher)	G
	Res., multi-pole (pole no. = pole no. for motor)	S
Encoder systems: Motors with DRIVE-CLiQ interface	Incremental encoder sin/cos 1 V _{pp}	D
	Absolute encoder EnDat 2048 pulses/rev. (shaft height 48 and higher)	F
	Absolute encoder EnDat 512 pulses/rev. (only shaft height 36)	L
	Basic abs. encoder EnDat 32 pulses/rev. (shaft height 48 and higher)	K
	Res., multi-pole (pole no. = pole no. for motor)	U
Holding brake:	Motor without holding brake	V
	Motor with holding brake	V

Order codes for type, type of construction and mounting position, refer to page 3/86

AC motors

Geared motors

1FK7 geared servomotors Helical geared motors

Selection and ordering data

Output (S3 -60%)	Output speed	Rated output torque	Max. permissible acceleration torque	Nominal ratio	Exact ratio	Cantilever force gearbox shaft extension	Overload factor
P_2 kW/HP	n_2 rpm	M_2 Nm/lb _f -ft	M_{2max} Nm/lb _f -ft	i_{nom}	i_{exact}	F_{rperm} N/lb _f	f_B
2.23/2.99	782	27.2/20	50/36.9	3.8	441/115	560/125.89	1.2
	511	41.6/30.7	102/75.2	5.9	47/8	917/206.15	1.6
2.22/2.98	289	73.5/54.2	138/101.7	10.5	841/81	1109/249.31	1.2
	196	108/79.6	230/169.5	15.5	703/46	1775/399.04	1.4
	128	166/122.3	350/258	23	845/36	3045/684.55	1.4
	86	247/182	550/405.4	35	975/28	5961/1340.09	1.5
2.23/2.99	60	355/261.6	600/442.2	50	1305/26	6734/1513.87	1.1
	43	495/364.8	850/626.5	70	10075/144	9229/2074.77	1.1
2.07/2.78	773	25.6/18.9	101/74.4	3.9	1363/351	799/125.89	3.3
2.08/2.79	511	38.8/28.6	115/84.8	5.9	47/8	917/206.15	2.5
2.07/2.78	289	68.5/50.5	138/101.7	10.5	847/81	1109/249.31	1.7
	196	101/74.4	230/169.5	15.5	703/46	1775/399.04	1.9
2.08/2.79	191	104/76.6	138/101.7	15.5	377/24	1273/286.18	1.1
	128	155/114.2	350/258	23	845/36	3045/684.55	1.9
2.07/2.78	127	156/115	230/169.5	24	637/27	2051/461.09	1.3
	86	230/169.5	550/405.4	35	975/28	5961/1340.09	2.0
2.08/2.79	86	231/170.2	350/258	35	1261/36	3479/782.11	1.3
2.07/2.78	60	329/242.5	920/678	50	1943/39	8241/1852.66	2.4
2.09/2.80	44	454/334.6	1380/1017.1	69	620/9	12344/2775.05	2.6
3.20/4.29	773	39.5/29.1	101/74.4	3.9	1363/351	799/125.89	1.7
	772	39.6/29.2	154/113.5	3.9	486/125	1125/252.91	2.5
	511	59.8/44.1	115/84.8	5.9	47/8	917/206.15	1.3
	518	59/43.5	176/129.7	5.8	666/115	1284/288.66	2.0
	320	95.6/70.5	230/169.5	9.4	2450/261	1509/339.24	1.6
	322	94.8/69.9	350/258	9.3	3575/384	2237/502.90	2.4
3.19/4.28	193	158/116.4	400/294.8	15.5	544/35	2654/596.65	1.7
3.18/4.26	190	160/117.9	600/442.2	16	63/4	4576/1028.73	2.5
3.19/4.28	128	238/175.4	550/405.4	23	1495/64	5219/1173.28	1.5
	128	238/175.4	850/626.5	23	1495/64	6402/1439.23	2.3
3.20/4.29	86	355/261.6	550/405.4	35	975/28	5961/1340.09	1.0
	86	355/261.6	1380/1017.1	35	1360/39	9838/2211.68	2.6
3.19/4.28	60	507/373.7	920/678	50	1943/39	2265/509.19	1.2
3.20/4.29	64	477/351.5	1971/1452.6	47	515/11	14923/3354.84	2.7
3.23/4.33	44	702/517.4	1380/1017.1	69	620/9	12344/2775.05	1.3
3.19/4.28	43	708/521.8	2300/1695.1	70	765/11	17027/3827.84	2.1

1FK7 geared servomotors Helical geared motors

Gearbox size	Motor frame size	Helical geared motors		Order codes			Total weight, approx. kg/lb
		Order No.		Gearbox type	Type	Type of construction mounting position	
C002	63	1FK7063-5AF71-1	5-Z	D01	G	H	17.1/37.7
C102	63	1FK7063-5AF71-1	5-Z	D12	G	H	22/48.5
C102	63	1FK7063-5AF71-1	5-Z	D13	G	H	22/48.5
C202	63	1FK7063-5AF71-1	5-Z	D24	G	H	26/57.3
C302	63	1FK7063-5AF71-1	5-Z	D35	G	H	31.1/68.6
C402	63	1FK7063-5AF71-1	5-Z	D46	G	H	41.3/91.1
C402	63	1FK7063-5AF71-1	5-Z	D47	G	H	41.3/91.1
C502	63	1FK7063-5AF71-1	5-Z	D58	G	H	52.9/116.6
C102	80	1FK7080-5AF71-1	5-Z	D11	G	H	21.7/47.9
C102	80	1FK7080-5AF71-1	5-Z	D12	G	H	21.7/47.9
C102	80	1FK7080-5AF71-1	5-Z	D13	G	H	21.7/47.9
C202	80	1FK7080-5AF71-1	5-Z	D24	G	H	25.7/56.7
C102	80	1FK7080-5AF71-1	5-Z	D14	G	H	21.7/47.9
C302	80	1FK7080-5AF71-1	5-Z	D35	G	H	30.8/67.9
C202	80	1FK7080-5AF71-1	5-Z	D25	G	H	25.7/56.7
C402	80	1FK7080-5AF71-1	5-Z	D46	G	H	41/90.4
C302	80	1FK7080-5AF71-1	5-Z	D36	G	H	30.8/67.9
C502	80	1FK7080-5AF71-1	5-Z	D57	G	H	52.6/116.0
C612	80	1FK7080-5AF71-1	5-Z	D68	G	H	67.9/149.7
C102	80	1FK7083-5AF71-1	5-Z	D11	G	H	26.9/59.3
C202	80	1FK7083-5AF71-1	5-Z	D21	G	H	30.9/68.1
C102	80	1FK7083-5AF71-1	5-Z	D12	G	H	26.9/59.3
C202	80	1FK7083-5AF71-1	5-Z	D22	G	H	30.9/68.1
C202	80	1FK7083-5AF71-1	5-Z	D23	G	H	30.9/68.1
C302	80	1FK7083-5AF71-1	5-Z	D33	G	H	36/79.4
C302	80	1FK7083-5AF71-1	5-Z	D34	G	H	36/79.4
C402	80	1FK7083-5AF71-1	5-Z	D44	G	H	46.2/101.9
C402	80	1FK7083-5AF71-1	5-Z	D45	G	H	46.2/101.9
C502	80	1FK7083-5AF71-1	5-Z	D55	G	H	57.8/127.5
C402	80	1FK7083-5AF71-1	5-Z	D46	G	H	46.2/101.9
C612	80	1FK7083-5AF71-1	5-Z	D66	G	H	73.1/161.2
C502	80	1FK7083-5AF71-1	5-Z	D57	G	H	57.8/127.5
C712	80	1FK7083-5AF71-1	5-Z	D77	G	H	108.4/239.0
C612	80	1FK7083-5AF71-1	5-Z	D68	G	H	73.1/161.2
C712	80	1FK7083-5AF71-1	5-Z	D78	G	H	108.4/239.0

Encoder systems: Motors without DRIVE-CLiQ interface	Incremental encoder sin/cos 1 V _{pp}	A
	Absolute encoder EnDat 2048 pulses/rev. (shaft height 48 and higher)	E
	Absolute encoder EnDat 512 pulses/rev. (only shaft height 36)	H
	Basic abs. encoder EnDat 32 pulses/rev. (shaft height 48 and higher)	G
	Res., multi-pole (pole no. = pole no. for motor)	S
Encoder systems: Motors with DRIVE-CLiQ interface	Incremental encoder sin/cos 1 V _{pp}	D
	Absolute encoder EnDat 2048 pulses/rev. (shaft height 48 and higher)	F
	Absolute encoder EnDat 512 pulses/rev. (only shaft height 36)	L
	Basic abs. encoder EnDat 32 pulses/rev. (shaft height 48 and higher)	K
	Res., multi-pole (pole no. = pole no. for motor)	U
Holding brake:	Motor without holding brake	U
	Motor with holding brake	V

Order codes for type, type of construction and mounting position, refer to page 3/86

AC motors

Geared motors

1FK7 geared servomotors Helical geared motors

Selection and ordering data

Output (S3 -60%)	Output speed	Rated output torque	Max. permissible acceleration torque	Nominal ratio	Exact ratio	Cantilever force gearbox shaft extension	Overload factor
P_2 kW/HP	n_2 rpm	M_2 Nm/lb _f -ft	M_{2max} Nm/lb _f -ft	i_{nom}	i_{exact}	F_{rperm} N/lb _f	f_B
3.66/4.91	774	45.1/33.2	251/185	3.9	190/49	1671/375.66	3.7
	512	68.2/50.3	288/212.3	5.9	2584/441	1917/430.96	2.8
3.64/4.88	322	108/79.6	350/258	9.3	3575/384	2237/502.90	2.2
3.66/4.91	193	181/133.4	400/294.8	15.5	544/35	2654/596.65	1.5
3.64/4.88	190	183/134.9	600/442.2	16	63/4	4576/1028.73	2.2
3.65/4.89	128	272/200.5	850/626.5	23	1495/64	6402/1439.23	2.1
	128	272/200.5	550/405.4	23	1495/64	5219/1173.28	1.3
3.66/4.91	86	406/299.2	1380/1017.1	35	1360/39	9838/2211.68	2.3
3.65/4.89	66	528/389.1	1380/1017.1	45	136/3	1852/416.35	1.7
	64	545/401.7	2300/1695.1	47	515/11	14923/3354.84	2.8
3.70/4.96	44	802/591.1	4140/3051.2	69	620/9	23146/5203.45	3.4
4.73/6.34	774	58.3/43	251/185	3.9	190/49	1671/375.66	2.5
4.72/6.33	512	88.1/64.9	288/212.3	5.9	2584/441	1917/430.96	1.9
	324	139/102.4	550/405.4	9.3	3445/372	3834/861.92	2.3
	322	140/130.2	350/258	9.3	3575/384	2237/502.90	1.4
	191	236/173.9	920/678	15.5	377/24	5609/1260.96	2.2
	190	237/174.7	600/442.2	16	63/4	4576/1028.73	1.5
4.70/6.30	128	351/258.7	850/626.5	23	1495/64	6402/1439.23	1.4
4.71/6.32	120	375/276.4	1650/1216.1	25	5185/208	8797/1977.65	2.5
4.75/6.37	86	527/388.4	2300/1695.1	35	2700/77	13552/3046.63	2.5
4.71/6.32	66	682/502.6	1380/1017.1	45	136/3	10737/2413.78	1.2
4.72/6.33	64	704/518.8	2300/1695.1	47	515/11	14923/3354.84	1.9
4.77/6.40	44	1036/763.5	4140/3051.2	69	620/9	23146/5203.45	2.3

1FK7 geared servomotors Helical geared motors

Gearbox size	Motor frame size	SH	Helical geared motors	Order codes			Total weight, approx. kg/lb
			Order No.	Gearbox type	Type	Type of construction mounting position	
C302	100		1FK7100-5AF71-1 ■ ■ 5 - Z	D31	G ■ ■	H ■ ■	38.2/84.2
C302	100		1FK7100-5AF71-1 ■ ■ 5 - Z	D32	G ■ ■	H ■ ■	38.2/84.2
C302	100		1FK7100-5AF71-1 ■ ■ 5 - Z	D33	G ■ ■	H ■ ■	38.2/84.2
C302	100		1FK7100-5AF71-1 ■ ■ 5 - Z	D34	G ■ ■	H ■ ■	38.2/84.2
C402	100		1FK7100-5AF71-1 ■ ■ 5 - Z	D44	G ■ ■	H ■ ■	48.4/106.7
C502	100		1FK7100-5AF71-1 ■ ■ 5 - Z	D55	G ■ ■	H ■ ■	60/132.3
C402	100		1FK7100-5AF71-1 ■ ■ 5 - Z	D45	G ■ ■	H ■ ■	48.4/106.7
C612	100		1FK7100-5AF71-1 ■ ■ 5 - Z	D66	G ■ ■	H ■ ■	75.3/166.0
C612	100		1FK7100-5AF71-1 ■ ■ 5 - Z	D67	G ■ ■	H ■ ■	75.3/166.0
C712	100		1FK7100-5AF71-1 ■ ■ 5 - Z	D77	G ■ ■	H ■ ■	110.6/243.9
C812	100		1FK7100-5AF71-1 ■ ■ 5 - Z	D88	G ■ ■	H ■ ■	170.2/375.3
C302	100		1FK7101-5AF71-1 ■ ■ 5 - Z	D31	G ■ ■	H ■ ■	43.8/96.6
C302	100		1FK7101-5AF71-1 ■ ■ 5 - Z	D32	G ■ ■	H ■ ■	43.8/96.6
C402	100		1FK7101-5AF71-1 ■ ■ 5 - Z	D43	G ■ ■	H ■ ■	43.8/96.6
C302	100		1FK7101-5AF71-1 ■ ■ 5 - Z	D33	G ■ ■	H ■ ■	54/119.1
C502	100		1FK7101-5AF71-1 ■ ■ 5 - Z	D54	G ■ ■	H ■ ■	65.6/144.7
C402	100		1FK7101-5AF71-1 ■ ■ 5 - Z	D44	G ■ ■	H ■ ■	54/119.1
C502	100		1FK7101-5AF71-1 ■ ■ 5 - Z	D55	G ■ ■	H ■ ■	65.6/144.7
C612	100		1FK7101-5AF71-1 ■ ■ 5 - Z	D65	G ■ ■	H ■ ■	80.9/178.4
C712	100		1FK7101-5AF71-1 ■ ■ 5 - Z	D76	G ■ ■	H ■ ■	116.2/256.2
C612	100		1FK7101-5AF71-1 ■ ■ 5 - Z	D67	G ■ ■	H ■ ■	80.9/178.4
C712	100		1FK7101-5AF71-1 ■ ■ 5 - Z	D77	G ■ ■	H ■ ■	116.2/256.2
C812	100		1FK7101-5AF71-1 ■ ■ 5 - Z	D88	G ■ ■	H ■ ■	175.8/387.6
Encoder systems: Motors without DRIVE-CLiQ interface	Incremental encoder sin/cos 1 V _{pp} Absolute encoder EnDat 2048 pulses/rev. (shaft height 48 and higher) Absolute encoder EnDat 512 pulses/rev. (only shaft height 36) Basic abs. encoder EnDat 32 pulses/rev. (shaft height 48 and higher) Res., multi-pole (pole no. = pole no. motor) Resolver, 2-pole		A E H G S T				
Encoder systems: Motors with DRIVE-CLiQ interface	Incremental encoder sin/cos 1 V _{pp} Absolute encoder EnDat 2048 pulses/rev. (shaft height 48 and higher) Absolute encoder EnDat 512 pulses/rev. (only shaft height 36) Basic abs. encoder EnDat 32 pulses/rev. (shaft height 48 and higher) Res., multi-pole (pole no. = pole no. motor) Resolver, 2-pole		D F L K U P				
Holding brake:	Motor without holding brake Motor with holding brake		U V				
Order codes for type, type of construction and mounting position, refer to page 3/86							

AC motors

Geared motors

1FK7 geared servomotors Helical geared motors

Selection and ordering data

Output (S3 -60%)	Output speed	Rated output torque	Max. permissible acceleration torque	Nominal ratio	Exact ratio	Cantilever force gearbox shaft extension	Overload factor
P_2 kW/HP	n_2 rpm	M_2 Nm/lb _f -ft	M_{2max} Nm/lb _f -ft	i_{nom}	i_{exact}	F_{rperm} N/lb _f	f_B
5.19/6.96	644	77/56.7	251/185	3.9	190/49	1671/375.66	1.9
5.18/6.95	423	117/86.2	288/212.3	5.9	2584/441	1917/430.96	2.0
5.19/6.96	424	117/86.2	420/309.5	5.9	377/64	3297/741.20	1.4
5.18/6.95	269	184/135.6	350/258	9.3	3575/384	2237/502.90	2.5
5.20/6.97	241	206/151.8	920/678	10.5	841/81	4886/1098.42	1.1
5.21/6.99	159	313/230.7	600/442.2	16	63/4	4576/1028.73	1.1
5.19/6.96	154	322/237.3	1650/1216.1	16	1037/64	7620/1713.05	2.9
5.20/6.97	107	464/342	850/626.5	23	1495/64	6402/1439.23	1.9
5.19/6.96	100	496/365.6	1650/1216.1	25	5185/208	8797/1977.65	1.1
5.23/7.01	72 71	694/511.5 703/518.1	1380/1017.1 4140/3051.2	35 35	1360/39 106/3	9838/2211.68 18528/4165.28	3.4 1.1
5.17/6.93	53	931/686.1	2300/1695.1	47	515/11	14923/3354.84	2.2
5.18/6.95	46	1076/793	4140/3051.2	54	704/13	21362/4802.39	1.2
5.16/6.92	36	1370/1009.7	4140/3051.2	69	620/9	23146/5203.45	1.1
7.92/10.62	770	98.2/72.4	366/269.7	4.7	841/216	2872/645.65	2.0
7.93/10.63	774	97.8/72.1	251/185	3.9	190/49	1671/375.66	1.4
7.95/10.66	513	148/109.1	650/479.1	5.9	117/20	4036/907.33	2.4
7.93/10.63	512	148/109.1	288/212.3	5.9	2584/441	1917/430.96	1.1
7.94/10.65	324 324	234/172.5 234/172.5	850/626.5 550/405.4	9.3 9.3	3445/372 3445/372	4703/1057.28 3834/861.92	2.0 1.3
7.92/10.62	191 185	396/291.9 409/301.4	920/678 1650/1216.1	16 16	377/24 1037/64	5609/1260.96 7620/1713.05	1.3 2.2
7.90/10.59	129 120	585/431.1 629/463.6	2300/1695.1 1650/1216.1	23 25	255/11 5185/208	11806/2654.11 8797/1977.65	2.1 1.4
7.93/10.63	85	891/656.7	4140/3051.2	36	106/3	18528/4165.28	2.5
7.96/10.67	86	884/651.5	2300/1695.1	35	2700/77	13552/3046.63	1.4
7.93/10.63	66	1148/846.1	4140/3051.2	46	592/13	20163/4532.84	2.0
7.91/10.61	64	1181/870.4	2300/1695.1	47	515/11	14923/3354.84	1.1
8.00/10.73	44	1737/1280.2	4140/3051.2	69	620/9	23146/5203.45	1.3

1FK7 geared servomotors Helical geared motors

Gearbox size	Motor frame size	Helical geared motors Order No.	Order codes			Total weight, approx. kg/lb
			Gearbox type	Type	Type of construction mounting position	
	SH					
C302	100	1FK7103-5AF71-1 ■ ■ 5-Z	D31	G ■ ■	H ■ ■	50.4/111.1
C302	100	1FK7103-5AF71-1 ■ ■ 5-Z	D32	G ■ ■	H ■ ■	50.4/111.1
C402	100	1FK7103-5AF71-1 ■ ■ 5-Z	D42	G ■ ■	H ■ ■	60.6/133.6
C302	100	1FK7103-5AF71-1 ■ ■ 5-Z	D33	G ■ ■	H ■ ■	50.4/111.1
C502	100	1FK7103-5AF71-1 ■ ■ 5-Z	D53	G ■ ■	H ■ ■	72.2/159.2
C402	100	1FK7103-5AF71-1 ■ ■ 5-Z	D44	G ■ ■	H ■ ■	60.6/133.6
C612	100	1FK7103-5AF71-1 ■ ■ 5-Z	D64	G ■ ■	H ■ ■	87.5/192.9
C502	100	1FK7103-5AF71-1 ■ ■ 5-Z	D55	G ■ ■	H ■ ■	72.2/159.2
C612	100	1FK7103-5AF71-1 ■ ■ 5-Z	D65	G ■ ■	H ■ ■	87.5/192.9
C612	100	1FK7103-5AF71-1 ■ ■ 5-Z	D66	G ■ ■	H ■ ■	87.5/192.9
C812	100	1FK7103-5AF71-1 ■ ■ 5-Z	D86	G ■ ■	H ■ ■	182.4/402.2
C712	100	1FK7103-5AF71-1 ■ ■ 5-Z	D77	G ■ ■	H ■ ■	122.8/270.8
C812	100	1FK7103-5AF71-1 ■ ■ 5-Z	D87	G ■ ■	H ■ ■	182.4/402.2
C812	100	1FK7103-5AF71-1 ■ ■ 5-Z	D88	G ■ ■	H ■ ■	182.4/402.2
C402	100	1FK7105-5AF71-1 ■ ■ 5-Z	D41	G ■ ■	H ■ ■	70.6/155.7
C302	100	1FK7105-5AF71-1 ■ ■ 5-Z	D31	G ■ ■	H ■ ■	60.4/133.2
C502	100	1FK7105-5AF71-1 ■ ■ 5-Z	D52	G ■ ■	H ■ ■	82.2/181.3
C302	100	1FK7105-5AF71-1 ■ ■ 5-Z	D32	G ■ ■	H ■ ■	60.4/133.2
C502	100	1FK7105-5AF71-1 ■ ■ 5-Z	D53	G ■ ■	H ■ ■	82.2/181.3
C402	100	1FK7105-5AF71-1 ■ ■ 5-Z	D43	G ■ ■	H ■ ■	70.6/155.7
C502	100	1FK7105-5AF71-1 ■ ■ 5-Z	D54	G ■ ■	H ■ ■	82.2/181.3
C612	100	1FK7105-5AF71-1 ■ ■ 5-Z	D64	G ■ ■	H ■ ■	97.5/215.0
C712	100	1FK7105-5AF71-1 ■ ■ 5-Z	D75	G ■ ■	H ■ ■	132.8/292.8
C612	100	1FK7105-5AF71-1 ■ ■ 5-Z	D65	G ■ ■	H ■ ■	97.5/215.0
C812	100	1FK7105-5AF71-1 ■ ■ 5-Z	D86	G ■ ■	H ■ ■	192.4/424.2
C712	100	1FK7105-5AF71-1 ■ ■ 5-Z	D76	G ■ ■	H ■ ■	132.8/292.8
C812	100	1FK7105-5AF71-1 ■ ■ 5-Z	D87	G ■ ■	H ■ ■	192.4/292.8
C712	100	1FK7105-5AF71-1 ■ ■ 5-Z	D77	G ■ ■	H ■ ■	132.8/292.8
C812	100	1FK7105-5AF71-1 ■ ■ 5-Z	D88	G ■ ■	H ■ ■	192.4/424.2

Encoder systems: Motors without DRIVE-CLiQ interface	Incremental encoder sin/cos 1 V _{pp}	A
	Absolute encoder EnDat 2048 pulses/rev. (shaft height 48 and higher)	E
	Absolute encoder EnDat 512 pulses/rev. (only shaft height 36)	H
	Basic abs. encoder EnDat 32 pulses/rev. (shaft height 48 and higher)	G
	Resolver, multi-pole (pole number = pole number for motor)	S
Resolver, 2-pole	T	
Encoder systems: Motors with DRIVE-CLiQ interface	Incremental encoder sin/cos 1 V _{pp}	D
	Absolute encoder EnDat 2048 pulses/rev. (shaft height 48 and higher)	F
	Absolute encoder EnDat 512 pulses/rev. (only shaft height 36)	L
	Basic abs. encoder EnDat 32 pulses/rev. (shaft height 48 and higher)	K
	Resolver, multi-pole (pole number = pole number for motor)	U
Resolver, 2-pole	P	
Holding brake:	Motor without holding brake	U
	Motor with holding brake	V

Order codes for type, type of construction and mounting position, refer to page 3/86

AC motors

Geared motors

1FK7 geared servomotors Offset shaft geared motors

Selection and ordering data

Output (S3 -60%) P_2 kW/HP	Output speed n_2 rpm	Rated output torque M_2 Nm/lb _f -ft	Max. permissible acceleration torque M_{2max} Nm/lb _f -ft	Nominal ratio i_{nom}	Exact ratio i_{exact}	Cantilever force gearbox shaft extension F_{rperm} N/lb _f	Overload factor f_B
0.30/0.40	696 464	4.07/3 6.11/4.5	24/17.7 33/24.3	4.3 6.5	56/13 84/13	1021/229.53 1169/262.80	4.7 4.5
	275 221	10.3/7.6 12.9/9.5	52/38.3 62/45.7	11 13.5	273/25 231/17	1392/312.94 1497/336.54	4.1 3.9
	130 86	21.8/16.1 33.1/24.4	114/84 120/88.4	23 35	3185/138 3575/102	1786/401.51 2053/461.53	4.2 2.9
0.41/0.55	696 464	5.64/4.2 8.46/6.2	45/33.2 64/47.2	4.3 6.5	56/13 84/13	1021/229.53 1169/262.80	6.7 6.3
	275 221	14.3/10.5 17.8/13.1	99/73 105/77.4	11 13.5	273/25 231/17	1392/312.94 1497/336.54	5.8 5.0
	130 86	30.2/22.3 45.9/33.8	120/88.4 120/88.4	23 35	3185/138 3575/102	1786/401.51 2053/461.53	3.4 2.2
0.79/1.06	696 464	10.9/8 16.3/12	45/33.2 64/47.2	4.3 6.5	56/13 84/13	1021/229.53 1169/262.80	3.6 3.4
	275 221	27.5/20.3 34.3/25.3	99/73 105/77.4	11 13.5	273/25 231/17	1392/312.94 1497/336.54	3.1 2.7
	130 128	58.2/42.9 59.1/43.6	120/88.4 233/171.7	23 23	3185/138 2320/99	1786/401.51 2308/468.28	1.8 3.4
	86 85	88.4/65.2 89.4/65.9	120/88.4 270/199	35 35	3575/102 390/11	2053/461.53 2650/595.75	1.2 2.6
	696 464	19.6/14.4 29.5/21.7	80/59 91/67.1	4.3 6.5	56/13 84/13	1021/229.53 1169/262.80	3.2 2.4
1.43/1.92	275 278	49.8/36.7 49.3/36.3	105/77.4 196/144.5	11 11	273/25 7303/676	1392/312.94 1783/400.84	1.7 3.1
	221 220	61.9/45.6 62.1/45.8	105/77.4 210/154.8	13.5 13.5	231/17 109/8	1497/336.54 1927/433.21	1.3 2.6
	128 85 86	107/78.9 162/119.4 160/117.9	270/199 270/199 450/331.7	23 35 35	2320/99 390/11 7252/207	2308/518.86 2650/595.75 3666/824.15	2.0 1.3 2.2
	696 464	30.5/22.5 45.8/33.8	80/59 91/67.1	4.3 6.5	56/13 84/13	1021/229.53 1169/262.80	1.7 1.3
	540 278	39.3/29 76.5/56.4	112/82.5 196/144.5	5.6 11	5341/962 7303/676	1428/321.03 1783/400.84	1.9 1.7
2.22/2.98	220 128 86	96.5/71.1 166/122.3 248/182.8	210/154.8 270/199 450/331.7	13.5 23 35	109/8 2320/99 7252/207	1927/433.21 2308/518.86 3666/824.15	1.4 1.1 1.2

Gearbox size	Motor frame size	SH	Offset shaft geared motors		Order codes			Total weight, approx. kg/lb
			Order No.		Gearbox type	Type	Type of construction mounting position	
F102	36	36	1FK7032-5AK71-1	5-Z	C11	G	H	13.8/30.4
F102	36	36	1FK7032-5AK71-1	5-Z	C12	G	H	13.8/30.4
F102	36	36	1FK7032-5AK71-1	5-Z	C13	G	H	13.8/30.4
F102	36	36	1FK7032-5AK71-1	5-Z	C14	G	H	13.8/30.4
F102	36	36	1FK7032-5AK71-1	5-Z	C15	G	H	13.8/30.4
F102	36	36	1FK7032-5AK71-1	5-Z	C16	G	H	13.8/30.4
F102	48	48	1FK7040-5AK71-1	5-Z	C11	G	H	14.6/32.2
F102	48	48	1FK7040-5AK71-1	5-Z	C12	G	H	14.6/32.2
F102	48	48	1FK7040-5AK71-1	5-Z	C13	G	H	14.6/32.2
F102	48	48	1FK7040-5AK71-1	5-Z	C14	G	H	14.6/32.2
F102	48	48	1FK7040-5AK71-1	5-Z	C15	G	H	14.6/32.2
F102	48	48	1FK7040-5AK71-1	5-Z	C16	G	H	14.6/32.2
F102	48	48	1FK7042-5AF71-1	5-Z	C11	G	H	15.9/35.1
F102	48	48	1FK7042-5AF71-1	5-Z	C12	G	H	15.9/35.1
F102	48	48	1FK7042-5AF71-1	5-Z	C13	G	H	15.9/35.1
F102	48	48	1FK7042-5AF71-1	5-Z	C14	G	H	15.9/35.1
F102	48	48	1FK7042-5AF71-1	5-Z	C15	G	H	15.9/35.1
F202	48	48	1FK7042-5AF71-1	5-Z	C25	G	H	24.1/53.1
F102	48	48	1FK7042-5AF71-1	5-Z	C16	G	H	15.9/35.1
F202	48	48	1FK7042-5AF71-1	5-Z	C26	G	H	24.1/53.1
F102	48	48	1FK7042-5AF71-1	5-Z	C16	G	H	15.9/35.1
F202	48	48	1FK7042-5AF71-1	5-Z	C26	G	H	24.1/53.1
F102	63	63	1FK7060-5AF71-1	5-Z	C11	G	H	18.6/41.0
F102	63	63	1FK7060-5AF71-1	5-Z	C12	G	H	18.6/41.0
F102	63	63	1FK7060-5AF71-1	5-Z	C13	G	H	18.6/41.0
F202	63	63	1FK7060-5AF71-1	5-Z	C23	G	H	26.8/59.1
F102	63	63	1FK7060-5AF71-1	5-Z	C14	G	H	18.6/41.0
F202	63	63	1FK7060-5AF71-1	5-Z	C24	G	H	26.8/59.1
F202	63	63	1FK7060-5AF71-1	5-Z	C25	G	H	26.8/59.1
F202	63	63	1FK7060-5AF71-1	5-Z	C26	G	H	26.8/59.1
F302	63	63	1FK7060-5AF71-1	5-Z	C36	G	H	34.4/75.9
F102	63	63	1FK7063-5AF71-1	5-Z	C11	G	H	22.3/49.2
F102	63	63	1FK7063-5AF71-1	5-Z	C12	G	H	22.3/49.2
F202	63	63	1FK7063-5AF71-1	5-Z	C22	G	H	30.5/67.3
F202	63	63	1FK7063-5AF71-1	5-Z	C23	G	H	30.5/67.3
F202	63	63	1FK7063-5AF71-1	5-Z	C24	G	H	30.5/67.3
F202	63	63	1FK7063-5AF71-1	5-Z	C25	G	H	30.5/67.3
F302	63	63	1FK7063-5AF71-1	5-Z	C36	G	H	38.1/84.0
Encoder systems:	Incremental encoder sin/cos 1 V _{pp}		Absolute encoder EnDat 2048 pulses/rev. (shaft height 48 and higher)		A			
Motors without DRIVE-CLiQ interface	Absolute encoder EnDat 512 pulses/rev. (only shaft height 36)		Basic abs. encoder EnDat 32 pulses/rev. (shaft height 48 and higher)		E			
	Res., multi-pole (pole no. = pole no. motor)		Resolver, 2-pole		H			
Encoder systems:	Incremental encoder sin/cos 1 V _{pp}		Absolute encoder EnDat 2048 pulses/rev. (shaft height 48 and higher)		G			
Motors with DRIVE-CLiQ interface	Absolute encoder EnDat 512 pulses/rev. (only shaft height 36)		Basic abs. encoder EnDat 32 pulses/rev. (shaft height 48 and higher)		S			
	Res., multi-pole (pole no. = pole no. motor)		Resolver, 2-pole		T			
Encoder systems:	Incremental encoder sin/cos 1 V _{pp}		Absolute encoder EnDat 2048 pulses/rev. (shaft height 48 and higher)		D			
Motors with DRIVE-CLiQ interface	Absolute encoder EnDat 512 pulses/rev. (only shaft height 36)		Basic abs. encoder EnDat 32 pulses/rev. (shaft height 48 and higher)		F			
	Res., multi-pole (pole no. = pole no. motor)		Resolver, 2-pole		L			
					K			
					U			
					P			
Holding brake:	Motor without holding brake		Motor with holding brake		U			
					V			
Order codes for type, type of construction and mounting position, refer to page 3/86								

AC motors

Geared motors

1FK7 geared servomotors Offset shaft geared motors

Selection and ordering data

Output (S3 -60%) P_2 kW/HP	Output speed n_2 rpm	Rated output torque M_2 Nm/lb _f -ft	Max. permissible acceleration torque M_{2max} Nm/lb _f -ft	Nominal ratio i_{nom}	Exact ratio i_{exact}	Cantilever force gearbox shaft extension F_{rperm} N/lb _f	Overload factor f_B
2.08/2.79	540	36.6/27	173/127.5	5.6	5341/962	1428/321.03	4.0
	278	71.3/52.5	210/154.8	11	7303/676	1783/400.84	2.5
	220	89.9/66.3	210/154.8	13.5	109/8	1927/433.21	2.0
	128	155/114.2	270/199	23	2320/99	2308/518.86	1.5
	128	155/114.2	450/331.7	24	588/25	3210/721.64	2.5
	86	231/170.2	450/331.7	35	7252/207	3666/824.15	1.7
3.20/4.29	540	56.5/41.6	173/127.5	5.6	5341/962	1428/321.03	2.0
	278	110/81.1	210/154.8	11	7303/676	1783/400.84	1.3
	278	110/81.1	350/258	11	1456/135	2475/556.40	2.1
	224	136/100.2	350/258	13.5	7696/575	2660/597.99	1.7
	221	138/101.7	550/405.4	13.5	5984/441	3296/740.97	2.6
	128	240/176.9	450/331.7	24	588/25	3210/721.64	1.2
3.66/4.91	516	67.7/49.9	482/355.2	5.8	3784/651	2484/558.43	4.8
	277	126/92.9	550/405.4	11	682/63	3057/687.24	2.9
	221	158/116.4	550/405.4	13.5	5984/441	3296/740.97	2.3
	129	270/199	700/515.9	23	325/14	3942/886.20	1.7
	129	271/199.7	1100/810.7	23	1885/81	5331/1198.46	2.7
	86	408/300.7	700/515.9	35	2210/63	4523/1016.82	1.1
4.72/6.33	516	87.4/64.4	482/355.2	5.8	3784/651	2484/558.43	3.2
	277	163/120.1	550/405.4	11	682/63	3057/687.24	1.9
	221	204/150.3	550/405.4	13.5	5984/441	3296/740.97	1.5
	220	205/151.1	1000/737	13.5	871/64	4458/1002.20	2.8
	129	349/257.2	700/515.9	23	325/14	3942/886.20	1.2
	85	529/389.9	1100/810.7	35	845/24	6120/1375.84	1.2
5.20/6.97	430	115/84.8	482/355.2	5.8	3784/651	2484/558.43	2.4
	231	215/158.5	550/405.4	11	682/63	3057/687.24	1.5
	231	215/158.5	991/730.4	11	2077/192	4130/928.47	2.6
	184	269/198.3	550/405.4	13.5	5984/441	3296/740.97	1.2
	183	270/199	1000/737	13.5	871/64	4458/1002.20	2.1
	108	460/339	1100/810.7	23	1885/81	5331/1198.46	1.4
7.93/10.63	529	143/105.4	766/564.5	5.7	1407/248	3330/748.62	2.9
	516	147/108.3	482/355.2	6	3784/651	2484/558.43	1.8
	277	273/201.2	991/730.4	11	2077/192	4130/928.47	2.0
	277	273/201.2	550/405.4	11	682/63	3057/687.24	1.1
	220	343/252.8	1000/737	13.6	871/64	4458/1002.20	1.6
	129	587/432.6	1100/810.7	24	1885/81	5331/1198.46	1.0

Gearbox size	Motor frame size	Offset shaft geared motors Order No.	Order codes			Total weight, approx. kg/lb
			Gearbox type	Type	Type of construction mounting position	
F202	80	1FK7080-5AF71-1 ■■■ 5-Z	C22	G ■■	H ■■	30.2/66.6
F202	80	1FK7080-5AF71-1 ■■ 5-Z	C23	G ■■	H ■■	30.2/66.6
F202	80	1FK7080-5AF71-1 ■■■ 5-Z	C24	G ■■	H ■■	30.2/66.6
F202	80	1FK7080-5AF71-1 ■■ 5-Z	C25	G ■■	H ■■	30.2/66.6
F302	80	1FK7080-5AF71-1 ■■■ 5-Z	C35	G ■■	H ■■	37.8/83.4
F302	80	1FK7080-5AF71-1 ■■ 5-Z	C36	G ■■	H ■■	37.8/83.4
F402	80	1FK7080-5AF71-1 ■■ 5-Z	C46	G ■■	H ■■	46.1/101.7
F202	80	1FK7083-5AF71-1 ■■■ 5-Z	C22	G ■■	H ■■	35.4/78.1
F202	80	1FK7083-5AF71-1 ■■ 5-Z	C23	G ■■	H ■■	35.4/78.1
F302	80	1FK7083-5AF71-1 ■■ 5-Z	C33	G ■■	H ■■	43/94.8
F302	80	1FK7083-5AF71-1 ■■ 5-Z	C34	G ■■	H ■■	43/94.8
F402	80	1FK7083-5AF71-1 ■■ 5-Z	C44	G ■■	H ■■	51.3/113.1
F302	80	1FK7083-5AF71-1 ■■ 5-Z	C35	G ■■	H ■■	43/94.8
F402	80	1FK7083-5AF71-1 ■■ 5-Z	C45	G ■■	H ■■	51.3/113.1
F402	80	1FK7083-5AF71-1 ■■ 5-Z	C46	G ■■	H ■■	51.3/113.1
F602	80	1FK7083-5AF71-1 ■■ 5-Z	C66	G ■■	H ■■	78.3/172.7
F402	100	1FK7100-5AF71-1 ■■■ 5-Z	C42	G ■■	H ■■	53.5/118.0
F402	100	1FK7100-5AF71-1 ■■ 5-Z	C43	G ■■	H ■■	53.3/118.0
F402	100	1FK7100-5AF71-1 ■■ 5-Z	C44	G ■■	H ■■	53.5/118.0
F402	100	1FK7100-5AF71-1 ■■ 5-Z	C45	G ■■	H ■■	53.3/118.0
F602	100	1FK7100-5AF71-1 ■■ 5-Z	C65	G ■■	H ■■	80.5/178.0
F402	100	1FK7100-5AF71-1 ■■ 5-Z	C46	G ■■	H ■■	53.3/118.0
F402	100	1FK7101-5AF71-1 ■■■ 5-Z	C42	G ■■	H ■■	59.1/130.3
F402	100	1FK7101-5AF71-1 ■■ 5-Z	C43	G ■■	H ■■	59.1/130.3
F402	100	1FK7101-5AF71-1 ■■ 5-Z	C44	G ■■	H ■■	59.1/130.3
F602	100	1FK7101-5AF71-1 ■■ 5-Z	C64	G ■■	H ■■	86.1/189.9
F402	100	1FK7101-5AF71-1 ■■ 5-Z	C45	G ■■	H ■■	59.1/130.3
F602	100	1FK7101-5AF71-1 ■■ 5-Z	C66	G ■■	H ■■	86.1/189.9
F402	100	1FK7103-5AF71-1 ■■■ 5-Z	C42	G ■■	H ■■	65.7/144.9
F402	100	1FK7103-5AF71-1 ■■ 5-Z	C43	G ■■	H ■■	65.7/144.9
F602	100	1FK7103-5AF71-1 ■■ 5-Z	C63	G ■■	H ■■	92.7/102.4
F402	100	1FK7103-5AF71-1 ■■ 5-Z	C44	G ■■	H ■■	65.7/144.9
F602	100	1FK7103-5AF71-1 ■■ 5-Z	C64	G ■■	H ■■	92.7/102.4
F602	100	1FK7103-5AF71-1 ■■ 5-Z	C65	G ■■	H ■■	92.7/102.4
F602	100	1FK7105-5AF71-1 ■■■ 5-Z	C62	G ■■	H ■■	103/227.1
F402	100	1FK7105-5AF71-1 ■■ 5-Z	C42	G ■■	H ■■	75.7/166.9
F602	100	1FK7105-5AF71-1 ■■ 5-Z	C63	G ■■	H ■■	103/227.1
F402	100	1FK7105-5AF71-1 ■■ 5-Z	C43	G ■■	H ■■	75.7/166.9
F602	100	1FK7105-5AF71-1 ■■ 5-Z	C64	G ■■	H ■■	103/227.1
F602	100	1FK7105-5AF71-1 ■■ 5-Z	C65	G ■■	H ■■	103/227.1

Encoder systems: Motors without DRIVE-CLiQ interface	Incremental encoder sin/cos 1 V _{pp}	A
	Absolute encoder EnDat 2048 pulses/rev. (shaft height 48 and higher)	E
	Absolute encoder EnDat 512 pulses/rev. (only shaft height 36)	H
	Basic abs. encoder EnDat 32 pulses/rev. (shaft height 48 and higher)	G
	Res., multi-pole (pole no. = pole no. motor)	S
Resolver, 2-pole	T	
Encoder systems: Motors with DRIVE-CLiQ interface	Incremental encoder sin/cos 1 V _{pp}	D
	Absolute encoder EnDat 2048 pulses/rev. (shaft height 48 and higher)	F
	Absolute encoder EnDat 512 pulses/rev. (only shaft height 36)	L
	Basic abs. encoder EnDat 32 pulses/rev. (shaft height 48 and higher)	K
	Res., multi-pole (pole no. = pole no. motor)	U
Resolver, 2-pole	P	
Holding brake:	Motor without holding brake	U
	Motor with holding brake	V

Order codes for type, type of construction and mounting position, refer to page 3/86

AC motors

Geared motors

1FK7 geared servomotors Bevel geared motors

Selection and ordering data

Output (S3-60%) P_2 kW/HP	Output speed n_2 rpm	Rated output torque M_2 Nm/lb _f -ft	Max. permissible acceleration torque M_{2max} Nm/lb _f -ft	Nominal ratio i_{nom}	Exact ratio i_{exact}	Cantilever force gearbox shaft extension F_{Tperm} N/lb _f	Overload factor f_B
0.30/0.40	750	3.78/2.8	22/16.2	4	4/1	1494/335.87	4.7
	500	5.68/4.2	31/22.8	6	6/1	1710/384.43	4.5
	296	9.59/7.1	48/35.4	10	507/50	2037/457.94	4.1
	179	15.8/11.6	73/53.8	16.5	117/7	2406/540.89	3.8
	129	22/16.2	102/75.2	23	1140/49	2686/603.84	3.8
	85	33.2/24.5	135/99.5	35	3686/105	3081/692.64	3.3
0.41/0.55	65	43.7/32.2	185/136.3	46	1849/40	4053/911.15	3.4
	43	65.7/48.4	159/117.2	69	6665/96	4641/1043.34	2.0
	750	5.24/3.9	42/31	4	4/1	1494/335.87	6.7
	500	7.86/5.8	59/43.5	6	6/1	1710/384.43	6.3
	296	13.3/9.8	92/67.8	10	507/50	2037/457.94	5.8
	179	21.9/16.1	122/89.9	16.5	117/7	2406/540.89	4.7
0.79/1.06	129	30.5/22.5	135/99.5	23	1140/49	2686/603.84	3.7
	85	46/33.9	135/99.5	35	3686/105	3081/692.64	2.5
	65	60.5/44.6	220/162.1	46	1849/40	4053/911.15	3.1
	750	10.1/7.4	42/31	4	4/1	1494/335.87	3.6
	500	15.1/11.1	59/43.5	6	6/1	1710/384.43	3.4
	296	25.6/18.9	92/67.8	10	507/50	2037/457.94	3.1
1.43/1.92	179	42.2/31.1	122/89.9	16.5	117/7	2406/540.89	2.5
	129	58.7/43.3	135/99.5	23	1140/49	2686/603.84	2.0
	85	88.5/65.2	135/99.5	35	3686/105	3081/692.64	1.3
	87	87.1/64.2	220/162.1	35	1935/56	3678/826.85	2.2
	750	18.2/13.4	76/56	4	4/1	1494/335.87	3.3
	500	27.4/20.2	87/64.1	6	6/1	1710/384.43	2.5
2.22/2.98	296	46.2/34	103/75.9	10	507/50	2037/457.94	1.8
	178	76.9/56.7	219/161.4	17	2967/176	2895/650.82	2.2
	129	106/78.1	220/162.1	23	2967/128	3220/723.89	1.6
	129	106/78.1	385/283.7	23	559/24	3762/845.74	2.8
	87	158/116.4	220/162.1	35	1935/56	3678/826.85	1.1
	86	158/116.4	385/283.7	35	903/26	4298/966.23	1.9
	65	211/155.5	385/283.7	46	1849/40	4728/1062.90	1.4
	65	211/155.5	600/442.2	46	602/13	7570/1701.81	2.2
	46	290/213.7	1000/737	65	12586/195	10154/2282.72	2.7
	750	28.3/20.9	76/56	4	4/1	1494/335.87	1.8
750	28.3/20.9	83/61.2	4	4/1	1793/403.08	2.0	
2.17/2.91	500	42.5/31.3	87/64.1	6	6/1	1710/384.43	1.4
	500	42.5/31.3	128/94.3	6	6/1	2394/538.20	2.0
	324	65.6/48.3	186/137.1	9.3	1075/116	2767/622.05	1.9
	178	119/87.7	219/161.4	17	2967/176	2895/650.82	1.2
	129	165/121.6	385/283.7	23	559/24	3762/845.74	1.5
	86	246/181.3	385/283.7	35	903/26	4298/1062.90	1.0
65	328/241.7	600/442.2	46	602/13	7570/1701.81	1.2	
2.17/2.91	46	450/331.7	1000/737	65	12586/195	10154/2282.72	1.5

1FK7 geared servomotors Bevel geared motors

3

Gearbox size	Motor frame size	SH	Bevel geared motors		Order codes			Total weight, approx. kg/lb
			Order No.		Gearbox type	Type	Type of construction mounting position	
K102	36		1FK7032-5AK71-1	5-Z	B11	G	H	12.3/27.1
K102	36		1FK7032-5AK71-1	5-Z	B12	G	H	12.3/27.1
K102	36		1FK7032-5AK71-1	5-Z	B13	G	H	12.3/27.1
K102	36		1FK7032-5AK71-1	5-Z	B14	G	H	12.3/27.1
K102	36		1FK7032-5AK71-1	5-Z	B15	G	H	12.3/27.1
K102	36		1FK7032-5AK71-1	5-Z	B16	G	H	12.3/27.1
K202	36		1FK7032-5AK71-1	5-Z	B27	G	H	19.8/43.7
K202	36		1FK7032-5AK71-1	5-Z	B28	G	H	19.8/43.7
K102	48		1FK7040-5AK71-1	5-Z	B11	G	H	13.1/28.9
K102	48		1FK7040-5AK71-1	5-Z	B12	G	H	13.1/28.9
K102	48		1FK7040-5AK71-1	5-Z	B13	G	H	13.1/28.9
K102	48		1FK7040-5AK71-1	5-Z	B14	G	H	13.1/28.9
K102	48		1FK7040-5AK71-1	5-Z	B15	G	H	13.1/28.9
K102	48		1FK7040-5AK71-1	5-Z	B16	G	H	13.1/28.9
K202	48		1FK7040-5AK71-1	5-Z	B27	G	H	20.6/45.4
K102	48		1FK7042-5AF71-1	5-Z	B11	G	H	14.4/31.8
K102	48		1FK7042-5AF71-1	5-Z	B12	G	H	14.4/31.8
K102	48		1FK7042-5AF71-1	5-Z	B13	G	H	14.4/31.8
K102	48		1FK7042-5AF71-1	5-Z	B14	G	H	14.4/31.8
K102	48		1FK7042-5AF71-1	5-Z	B15	G	H	14.4/31.8
K102	48		1FK7042-5AF71-1	5-Z	B16	G	H	14.4/31.8
K202	48		1FK7042-5AF71-1	5-Z	B26	G	H	21.9/48.3
K102	63		1FK7060-5AF71-1	5-Z	B11	G	H	17.1/37.7
K102	63		1FK7060-5AF71-1	5-Z	B12	G	H	17.1/37.7
K102	63		1FK7060-5AF71-1	5-Z	B13	G	H	17.1/37.7
K202	63		1FK7060-5AF71-1	5-Z	B24	G	H	24.6/54.2
K202	63		1FK7060-5AF71-1	5-Z	B25	G	H	24.6/54.2
K302	63		1FK7060-5AF71-1	5-Z	B35	G	H	29.6/65.3
K202	63		1FK7060-5AF71-1	5-Z	B26	G	H	24.6/54.2
K302	63		1FK7060-5AF71-1	5-Z	B36	G	H	29.6/65.3
K302	63		1FK7060-5AF71-1	5-Z	B37	G	H	29.6/65.3
K402	63		1FK7060-5AF71-1	5-Z	B47	G	H	43.1/95.0
K513	63		1FK7060-5AF71-1	5-Z	B58	G	H	48.9/107.8
K102	63		1FK7063-5AF71-1	5-Z	B11	G	H	20.8/45.9
K202	63		1FK7063-5AF71-1	5-Z	B21	G	H	28.3/62.4
K102	63		1FK7063-5AF71-1	5-Z	B12	G	H	20.8/45.9
K302	63		1FK7063-5AF71-1	5-Z	B32	G	H	33.3/73.4
K302	63		1FK7063-5AF71-1	5-Z	B33	G	H	33.3/73.4
K202	63		1FK7063-5AF71-1	5-Z	B24	G	H	28.3/62.4
K302	63		1FK7063-5AF71-1	5-Z	B35	G	H	33.3/73.4
K302	63		1FK7063-5AF71-1	5-Z	B36	G	H	33.3/73.4
K402	63		1FK7063-5AF71-1	5-Z	B47	G	H	46.8/103.2
K513	63		1FK7063-5AF71-1	5-Z	B58	G	H	52.6/116.0

Encoder systems: Motors without DRIVE-CLiQ interface	Incremental encoder sin/cos 1 V _{pp}	A
	Absolute encoder EnDat 2048 pulses/rev. (shaft height 48 and higher)	E
	Absolute encoder EnDat 512 pulses/rev. (only shaft height 36)	H
	Basic abs. encoder EnDat 32 pulses/rev. (shaft height 48 and higher)	G
Encoder systems: Motors with DRIVE-CLiQ interface	Res., multi-pole (pole no. = pole no. motor)	S
	Resolver, 2-pole	T
	Incremental encoder sin/cos 1 V _{pp}	D
	Absolute encoder EnDat 2048 pulses/rev. (shaft height 48 and higher)	F
Holding brake: Motor without holding brake Motor with holding brake	Absolute encoder EnDat 512 pulses/rev. (only shaft height 36)	L
	Basic abs. encoder EnDat 32 pulses/rev. (shaft height 48 and higher)	K
	Res., multi-pole (pole no. = pole no. motor)	U
	Resolver, 2-pole	P
		V

Order codes for type, type of construction and mounting position, refer to page 3/86

AC motors

Geared motors

1FK7 geared servomotors Bevel geared motors

Selection and ordering data

Output (S3-60%) P_2 kW/HP	Output speed n_2 rpm	Rated output torque M_2 Nm/lb _f -ft	Max. permissible acceleration torque M_{2max} Nm/lb _f -ft	Nominal ratio i_{nom}	Exact ratio i_{exact}	Cantilever force gearbox shaft extension F_{rperm} N/lb _f	Overload factor f_B
2.07/2.78	750	26.4/19.5	135/99.5	4	4/1	1793/403.08	4.4
	500	39.6/29.2	155/114.2	6	6/1	2052/461.31	3.3
	298	66.4/48.9	184/135.6	10	2881/286	2439/548.31	2.4
	177	112/82.5	384/283	17	559/33	3383/760.53	2.9
	129	153/112.8	220/162.1	23	2967/128	3220/723.89	1.2
	129	154/113.5	385/283.7	23	559/24	3762/845.74	2.1
	86	229/168.8	600/442.2	35	4171/120	6879/1546.47	2.2
	2.03/2.72	62	313/230.7	1000/737	48	2697/56	9210/2070.50
39		495/364.8	1600/1179.2	76	126697/1664	12763/2869.25	2.7
3.20/4.29	750	40.7/30	135/99.5	4	4/1	1793/403.08	2.2
	500	61.1/45	155/114.2	6	6/1	2052/461.31	1.7
	500	61.1/45	271/199.7	6	6/1	2394/538.20	2.9
	298	103/75.9	184/135.6	10	2881/286	2439/548.31	1.2
	324	94.4/69.6	314/231.4	9.3	1075/116	2767/622.05	2.2
	177	173/127.5	384/283	17	559/33	3383/760.53	1.5
	177	173/127.5	575/423.8	17	559/33	5414/1217.12	2.2
	129	237/174.7	385/283.7	23	559/24	3762/845.74	1.1
	3.14/4.21	123	244/179.8	1000/737	24	11687/480	7337/1649.43
93		324/238.8	1000/737	32	20677/640	8062/1812.42	2.0
62		483/356	1000/737	48	2697/56	9210/2070.50	1.4
	63	479/353	1600/1179.2	48	39711/832	10923/2455.60	2.2
	46	648/477.6	1000/737	65	12586/195	10154/2282.72	1.0
	46	651/479.8	2574/	65	33201/512	16635/3739.71	2.6
	3.19/4.28	86	354/260.9	600/442.2	35	4171/120	6879/1546.47
3.66/4.91		750	46.6/34.3	356/262.4	4	4/1	3346/752.21
	500	69.8/51.4	407/300	6	6/1	3830/861.02	3.9
	297	118/87	484/356.7	10	1333/132	4556/1024.23	2.7
	177	197/145.2	575/423.8	17	559/33	5414/1217.12	1.9
	129	271/199.7	600/442.2	23	559/24	6020/1353.36	1.5
	3.60/4.83	123	279/205.6	1000/737	24	11687/480	7337/1649.43
93		371/273.4	1000/737	32	20677/640	8062/1812.42	1.8
87		397/292.6	1600/1179.2	35	35441/1024	9813/2206.06	2.7
	60	572/421.6	2600/1916.2	50	166005/3328	15242/3426.55	3.0
	46	744/548.3	2600/1916.2	65	33201/512	16635/3739.71	2.3

1FK7 geared servomotors Bevel geared motors

Gearbox size	Motor frame size	SH	Bevel geared motors		Order codes			Total weight, approx. kg/lb
			Order No.		Gearbox type	Type	Type of construction mounting position	
K202	80		1FK7080-5AF71-1	5-Z	B21	G	H	28/61.7
K202	80		1FK7080-5AF71-1	5-Z	B22	G	H	28/61.7
K202	80		1FK7080-5AF71-1	5-Z	B23	G	H	28/61.7
K302	80		1FK7080-5AF71-1	5-Z	B34	G	H	33/72.8
K202	80		1FK7080-5AF71-1	5-Z	B25	G	H	28/61.7
K302	80		1FK7080-5AF71-1	5-Z	B35	G	H	33/72.8
K402	80		1FK7080-5AF71-1	5-Z	B46	G	H	46.5/102.5
K513	80		1FK7080-5AF71-1	5-Z	B57	G	H	52.3/115.3
K613	80		1FK7080-5AF71-1	5-Z	B68	G	H	73.8/162.7
K202	80		1FK7083-5AF71-1	5-Z	B21	G	H	33.2/73.2
K202	80		1FK7083-5AF71-1	5-Z	B22	G	H	33.2/73.2
K302	80		1FK7083-5AF71-1	5-Z	B32	G	H	38.2/84.2
K202	80		1FK7083-5AF71-1	5-Z	B23	G	H	33.2/73.2
K302	80		1FK7083-5AF71-1	5-Z	B33	G	H	38.2/84.2
K302	80		1FK7083-5AF71-1	5-Z	B34	G	H	38.2/84.2
K402	80		1FK7083-5AF71-1	5-Z	B44	G	H	51.7/114.0
K302	80		1FK7083-5AF71-1	5-Z	B35	G	H	38.2/84.2
K513	80		1FK7083-5AF71-1	5-Z	B55	G	H	57.5/126.8
K513	80		1FK7083-5AF71-1	5-Z	B56	G	H	57.5/126.8
K513	80		1FK7083-5AF71-1	5-Z	B57	G	H	57.5/126.8
K613	80		1FK7083-5AF71-1	5-Z	B67	G	H	79/174.2
K513	80		1FK7083-5AF71-1	5-Z	B58	G	H	57.5/126.8
K713	80		1FK7083-5AF71-1	5-Z	B78	G	H	107.3/236.6
K402	80		1FK7083-5AF71-1	5-Z	B46	G	H	51.7/114.0
K402	100		1FK7100-5AF71-1	5-Z	B41	G	H	53.9/118.9
K402	100		1FK7100-5AF71-1	5-Z	B42	G	H	53.9/118.9
K402	100		1FK7100-5AF71-1	5-Z	B43	G	H	53.9/118.9
K402	100		1FK7100-5AF71-1	5-Z	B44	G	H	53.9/118.9
K402	100		1FK7100-5AF71-1	5-Z	B45	G	H	53.9/118.9
K513	100		1FK7100-5AF71-1	5-Z	B55	G	H	59.7/131.6
K513	100		1FK7100-5AF71-1	5-Z	B56	G	H	59.7/131.6
K613	100		1FK7100-5AF71-1	5-Z	B66	G	H	81.2/179.1
K713	100		1FK7100-5AF71-1	5-Z	B77	G	H	109.5/241.5
K713	100		1FK7100-5AF71-1	5-Z	B78	G	H	109.5/241.5

Encoder systems: Motors without DRIVE-CLiQ interface	Incremental encoder sin/cos 1 V _{pp}	A
	Absolute encoder EnDat 2048 pulses/rev. (shaft height 48 and higher)	E
	Absolute encoder EnDat 512 pulses/rev. (only shaft height 36)	H
	Basic abs. encoder EnDat 32 pulses/rev. (shaft height 48 and higher)	G
Encoder systems: Motors with DRIVE-CLiQ interface	Res., multi-pole (pole no. = pole no. motor)	S
	Resolver, 2-pole	T
	Incremental encoder sin/cos 1 V _{pp}	D
	Absolute encoder EnDat 2048 pulses/rev. (shaft height 48 and higher)	F
Encoder systems: Motors with DRIVE-CLiQ interface	Absolute encoder EnDat 512 pulses/rev. (only shaft height 36)	L
	Basic abs. encoder EnDat 32 pulses/rev. (shaft height 48 and higher)	K
	Res., multi-pole (pole no. = pole no. motor)	U
	Resolver, 2-pole	P
Holding brake:	Motor without holding brake	U
	Motor with holding brake	V

Order codes for type, type of construction and mounting position, refer to page 3/86

AC motors

Geared motors

1FK7 geared servomotors Bevel geared motors

Selection and ordering data

Output (S3-60%) P_2 kW/HP	Output speed n_2 rpm	Rated output torque M_2 Nm/lb _f -ft	Max. permissible acceleration torque M_{2max} Nm/lb _f -ft	Nominal ratio i_{nom}	Exact ratio i_{exact}	Cantilever force gearbox shaft extension F_{rperm} N/lb _f	Overload factor f_B
4.72/6.33	750	60.1/44.3	356/262.4	4	4/1	3346/752.21	3.4
	500	90.2/66.5	407/300	6	6/1	3830/861.02	2.6
4.66/6.25	297	152/112	484/356.7	10	1333/132	4556/1024.23	1.8
	177	255/187.9	575/423.8	17	559/33	5414/1217.12	1.3
	186	238/175.4	1000/737	16	26071/1620	6391/1436.76	2.4
4.64/6.22	123	361/266.1	1000/737	24	11687/480	7337/1649.43	1.6
	125	356/262.4	1584/1167.4	24	24583/1024	8687/1952.92	2.6
	87	513/378.1	1600/1179.2	35	35441/1024	9813/2206.06	1.8
4.63/6.21	85	525/386.9	2600/1916.2	35	567/16	13600/3057.42	2.8
	60	739/544.6	2600/1916.2	50	166005/3328	15242/3426.55	2.0
4.67/6.26	46	961/708.3	2600/1916.2	65	33201/512	16635/3739.71	1.6
5.17/6.93	46	969/714.2	4650/3427.1	65	188387/2880	21991/4943.80	2.8
5.20/6.97	625	79/58.2	356/262.4	4	4/1	3346/752.21	2.5
5.19/6.96	417	119/87.7	407/300	6	6/1	3830/861.02	1.9
5.13/6.88	248	200/147.4	484/356.7	10	1333/132	4556/1024.23	1.4
	246	199/146.7	900/663.3	10	203/20	5481/1232.18	2.6
5.16/6.92	155	315/232.2	1000/737	16	26071/1620	6391/1436.76	1.8
	158	310/228.5	1380/1017.1	16	54839/3456	7567/1701.14	2.5
	103	477/351.5	1000/737	24	11687/480	7337/1649.43	1.2
5.12/6.87	104	470/346.4	1584/1167.4	24	24583/1024	8687/1952.92	1.9
	72	678/499.7	1600/1179.2	35	35441/1024	9813/2206.06	1.3
5.09/6.83	71	694/511.5	2600/1916.2	35	567/16	13600/3057.42	2.1
7.93/10.63	50	978/720.8	2600/1916.2	50	166005/3328	15242/3426.55	1.5
7.81/10.47	51	960/707.5	4650/3427.1	49	5487/112	19971/4489.68	2.8
7.80/10.46	39	1271/936.7	2600/1916.2	65	33201/512	16635/3739.71	1.2
7.84/10.51	38	1280/943.4	4650/3427.1	65	188387/2880	21991/4943.80	2.1
	750	101/74.4	356/262.4	4	4/1	3346/752.21	1.9
7.83/10.50	500	151/111.3	407/300	6	6/1	3830/861.02	1.5
	296	252/185.7	900/663.3	10	203/20	5481/1232.18	1.9
7.93/10.63	297	255/187.9	484/356.7	10	1333/132	4556/1024.23	1.0
7.80/10.46	189	394/290.4	1380/1017.1	16	54839/3456	7567/1701.14	1.9
	186	400/294.8	1000/737	16	26071/1620	6391/1436.76	1.4
7.84/10.51	125	597/440	1584/1167.4	24	24583/1024	8687/1952.92	1.4
	119	626/461.4	2600/1916.2	25	64449/2560	12135/2728.07	2.3
7.80/10.46	85	881/649.3	2600/1916.2	35	567/16	3276/736.48	1.6
7.83/10.50	83	898/661.8	4255/3135.9	36	2891/80	18045/4056.70	2.6
	61	1218/897.7	4650/3427.1	49	5487/112	19971/4489.68	2.1
	60	1240/913.9	2600/1916.2	50	166005/3328	15242/3426.55	1.1
7.83/10.50	46	1626/1198.4	4650/3427.1	65	188387/2880	21991/4943.80	1.5

1FK7 geared servomotors Bevel geared motors

Gearbox size	Motor frame size	SH	Bevel geared motors		Order codes			Total weight, approx. kg/lb
			Order No.		Gearbox type	Type	Type of construction mounting position	
K402	100		1FK7101-5AF71-1	5 - Z	B41	G	H	59.5/131.2
K402	100		1FK7101-5AF71-1	5 - Z	B42	G	H	59.5/131.2
K402	100		1FK7101-5AF71-1	5 - Z	B43	G	H	59.5/131.2
K402	100		1FK7101-5AF71-1	5 - Z	B44	G	H	59.5/131.2
K513	100		1FK7101-5AF71-1	5 - Z	B54	G	H	65.3/144.0
K513	100		1FK7101-5AF71-1	5 - Z	B55	G	H	65.3/144.0
K613	100		1FK7101-5AF71-1	5 - Z	B65	G	H	86.8/191.4
K613	100		1FK7101-5AF71-1	5 - Z	B66	G	H	86.8/191.4
K713	100		1FK7101-5AF71-1	5 - Z	B76	G	H	115.1/253.8
K713	100		1FK7101-5AF71-1	5 - Z	B77	G	H	115.1/253.8
K713	100		1FK7101-5AF71-1	5 - Z	B78	G	H	115.1/253.8
K813	100		1FK7101-5AF71-1	5 - Z	B88	G	H	168.5/371.5
K402	100		1FK7103-5AF71-1	5 - Z	B41	G	H	66.1/145.8
K402	100		1FK7103-5AF71-1	5 - Z	B42	G	H	66.1/145.8
K402	100		1FK7103-5AF71-1	5 - Z	B43	G	H	66.1/145.8
K513	100		1FK7103-5AF71-1	5 - Z	B53	G	H	71.9/158.5
K513	100		1FK7103-5AF71-1	5 - Z	B54	G	H	71.9/158.5
K613	100		1FK7103-5AF71-1	5 - Z	B64	G	H	93.4/206.0
K513	100		1FK7103-5AF71-1	5 - Z	B55	G	H	71.9/158.5
K613	100		1FK7103-5AF71-1	5 - Z	B65	G	H	93.4/206.0
K613	100		1FK7103-5AF71-1	5 - Z	B66	G	H	93.4/206.0
K713	100		1FK7103-5AF71-1	5 - Z	B76	G	H	121.7/268.4
K713	100		1FK7103-5AF71-1	5 - Z	B77	G	H	121.7/268.4
K813	100		1FK7103-5AF71-1	5 - Z	B87	G	H	175.1/386.1
K713	100		1FK7103-5AF71-1	5 - Z	B78	G	H	121.7/268.4
K813	100		1FK7103-5AF71-1	5 - Z	B88	G	H	175.1/386.1
K402	100		1FK7105-5AF71-1	5 - Z	B41	G	H	76.1/167.8
K402	100		1FK7105-5AF71-1	5 - Z	B42	G	H	76.1/167.8
K513	100		1FK7105-5AF71-1	5 - Z	B53	G	H	82/180.8
K402	100		1FK7105-5AF71-1	5 - Z	B43	G	H	76.1/167.8
K613	100		1FK7105-5AF71-1	5 - Z	B64	G	H	103/227.1
K513	100		1FK7105-5AF71-1	5 - Z	B54	G	H	82/180.8
K613	100		1FK7105-5AF71-1	5 - Z	B65	G	H	103/227.1
K713	100		1FK7105-5AF71-1	5 - Z	B75	G	H	132/291.1
K713	100		1FK7105-5AF71-1	5 - Z	B76	G	H	132/291.1
K713	100		1FK7105-5AF71-1	5 - Z	B77	G	H	132/291.1
K813	100		1FK7105-5AF71-1	5 - Z	B86	G	H	185/407.9
K813	100		1FK7105-5AF71-1	5 - Z	B87	G	H	185/407.9
K713	100		1FK7105-5AF71-1	5 - Z	B77	G	H	132/291.1
K813	100		1FK7105-5AF71-1	5 - Z	B88	G	H	185/407.9
Encoder systems:	Incremental encoder sin/cos 1 V _{pp}	A						
	Absolute encoder EnDat 2048 pulses/rev. (shaft height 48 and higher)	E						
Motors without DRIVE-CLiQ interface	Absolute encoder EnDat 512 pulses/rev. (only shaft height 36)	H						
	Basic abs. encoder EnDat 32 pulses/rev. (shaft height 48 and higher)	G						
	Res., multi-pole (pole no. = pole no. motor)	S						
	Resolver, 2-pole	T						
Encoder systems:	Incremental encoder sin/cos 1 V _{pp}	D						
	Absolute encoder EnDat 2048 pulses/rev. (shaft height 48 and higher)	F						
Motors with DRIVE-CLiQ interface	Absolute encoder EnDat 512 pulses/rev. (only shaft height 36)	L						
	Basic abs. encoder EnDat 32 pulses/rev. (shaft height 48 and higher)	K						
	Res., multi-pole (pole no. = pole no. motor)	U						
	Resolver, 2-pole	P						
Holding brake:	Motor without holding brake	U						
	Motor with holding brake	V						

Order codes for type, type of construction and mounting position, refer to page 3/86

AC motors

Geared motors

1FK7 geared servomotors Worm geared motors

Selection and ordering data

Output (S3-60%)	Output speed	Rated output torque	Max. permissible acceleration torque	Nominal ratio	Exact ratio	Cantilever force gearbox shaft extension	Overload factor
P_2 kW/HP	n_2 rpm	M_2 Nm/lb _f -ft	M_{2max} Nm/lb _f -ft	i_{nom}	i_{exact}	F_{rperm} N/lb _f	f_B
0.28/0.38	312	8.5/6.3	43/31.7	9.6	1107/115	1689/379.70	4.1
	172	15.3/11.3	73/53.8	17.5	297/17	1938/435.68	3.9
0.27/0.36	128	20.2/14.9	82/60.4	23	117/5	2271/510.54	3.3
	86	30/22.1	125/92.1	35	873/25	2441/548.76	3.4
0.24/0.32	51	45.6/33.6	88/64.9	59	117/2	3082/692.86	1.6
	52	45.8/33.8	172/126.8	58	405/7	2889/649.48	3.1
	40	57.7/42.5	96/70.8	75	747/10	3343/751.54	1.4
	43	54.8/40.4	184/135.6	70	279/4	3075/691.29	2.7
0.38/0.51	172	21.2/15.6	110/81.1	17.5	297/17	1938/435.68	4.4
	86	41.6/30.7	150/110.6	35	873/25	2441/548.76	3.0
0.35/0.47	52	63.4/46.7	172/126.8	58	405/7	2889/649.48	2.3
	43	75.9/55.9	184/135.6	70	279/4	3075/691.29	2.0
0.73/0.98	172	40.8/30.1	110/81.1	17.5	297/17	1938/435.68	2.3
	130	53.6/39.5	132/97.3	23	162/7	2128/478.40	2.1
0.72/0.97	86	80.1/59	150/110.6	35	873/25	2441/548.76	1.6
	86	79.9/58.9	252/185.7	35	243/7	3411/766.83	2.7
0.66/0.89	52	122/89.9	172/126.8	58	405/7	2889/649.48	1.2
0.69/0.93	52	126/92.9	302/222.6	58	1863/32	4053/911.15	2.1
0.66/0.89	43	146/107.6	184/135.6	70	279/4	3075/691.29	1.1
0.68/0.91	43	151/111.3	324/238.8	70	351/5	4314/969.83	1.9
1.35/1.81	326	39.5/29.1	74/54.5	9.2	46/5	1565/351.83	1.5
1.33/1.78	172	73.7/54.3	110/81.1	17.5	297/17	1938/435.68	1.2
	171	74.4/54.8	217/159.9	17.5	351/20	2717/610.81	2.3
1.31/1.76	129	97.9/72.2	259/190.9	23	1863/80	2986/671.28	2.1
	86	144/106.1	310/228.5	35	243/7	3411/766.83	1.7
	86	146/107.6	498/367	35	2268/65	4881/1097.30	2.7
1.24/1.66	52	227/167.3	302/222.6	58	1863/32	4053/911.15	1.0
	51	232/171	561/413.5	59	117/2	5799/1303.67	1.9
	43	275/202.7	609/448.8	70	2241/32	6157/1384.16	1.7
	43	277/204.1	791/583	70	279/4	7994/1797.13	2.2

1FK7 geared servomotors Worm geared motors

Gearbox size	Motor frame size	Worm geared motors Order No.	Order codes			Total weight, approx. kg/lb
			Gearbox type	Type	Type of construction mounting position	
	SH					
S002 S102	36 36	1FK7032-5AK71-1 ■ ■ ■ 5-Z 1FK7032-5AK71-1 ■ ■ ■ 5-Z	E03 E14	G ■ ■ G ■ ■	H ■ ■ H ■ ■	6.6/14.6 12.9/28.4
S002 S102	36 36	1FK7032-5AK71-1 ■ ■ ■ 5-Z 1FK7032-5AK71-1 ■ ■ ■ 5-Z	E05 E16	G ■ ■ G ■ ■	H ■ ■ H ■ ■	6.6/14.6 12.9/28.4
S002 S102	36 36	1FK7032-5AK71-1 ■ ■ ■ 5-Z 1FK7032-5AK71-1 ■ ■ ■ 5-Z	E07 E17	G ■ ■ G ■ ■	H ■ ■ H ■ ■	6.6/14.6 12.9/28.4
S002 S102	36 36	1FK7032-5AK71-1 ■ ■ ■ 5-Z 1FK7032-5AK71-1 ■ ■ ■ 5-Z	E08 E18	G ■ ■ G ■ ■	H ■ ■ H ■ ■	6.6/14.6 12.9/28.4
S102 S102	48 48	1FK7040-5AK71-1 ■ ■ ■ 5-Z 1FK7040-5AK71-1 ■ ■ ■ 5-Z	E14 E16	G ■ ■ G ■ ■	H ■ ■ H ■ ■	13.7/30.2 13.7/30.2
S102 S102	48 48	1FK7040-5AK71-1 ■ ■ ■ 5-Z 1FK7040-5AK71-1 ■ ■ ■ 5-Z	E17 E18	G ■ ■ G ■ ■	H ■ ■ H ■ ■	13.7/30.2 13.7/30.2
S102 S102	48 48	1FK7042-5AF71-1 ■ ■ ■ 5-Z 1FK7042-5AF71-1 ■ ■ ■ 5-Z	E14 E15	G ■ ■ G ■ ■	H ■ ■ H ■ ■	15/33.1 15/33.1
S102 S202	48 48	1FK7042-5AF71-1 ■ ■ ■ 5-Z 1FK7042-5AF71-1 ■ ■ ■ 5-Z	E16 E26	G ■ ■ G ■ ■	H ■ ■ H ■ ■	15/33.1 22.5/49.6
S102	48	1FK7042-5AF71-1 ■ ■ ■ 5-Z	E17	G ■ ■	H ■ ■	15/33.1
S202	48	1FK7042-5AF71-1 ■ ■ ■ 5-Z	E27	G ■ ■	H ■ ■	22.5/49.6
S102	48	1FK7042-5AF71-1 ■ ■ ■ 5-Z	E18	G ■ ■	H ■ ■	15/33.1
S202	48	1FK7042-5AF71-1 ■ ■ ■ 5-Z	E28	G ■ ■	H ■ ■	22.5/49.6
S102	63	1FK7060-5AF71-1 ■ ■ ■ 5-Z	E13	G ■ ■	H ■ ■	17.7/39.0
S102 S202	63 63	1FK7060-5AF71-1 ■ ■ ■ 5-Z 1FK7060-5AF71-1 ■ ■ ■ 5-Z	E14 E24	G ■ ■ G ■ ■	H ■ ■ H ■ ■	17.7/39.0 25.2/55.6
S202 S202 S302	63 63 63	1FK7060-5AF71-1 ■ ■ ■ 5-Z 1FK7060-5AF71-1 ■ ■ ■ 5-Z 1FK7060-5AF71-1 ■ ■ ■ 5-Z	E25 E26 E36	G ■ ■ G ■ ■ G ■ ■	H ■ ■ H ■ ■ H ■ ■	25.2/55.6 25.2/55.6 34.4/75.9
S202 S302	63 63	1FK7060-5AF71-1 ■ ■ ■ 5-Z 1FK7060-5AF71-1 ■ ■ ■ 5-Z	E27 E37	G ■ ■ G ■ ■	H ■ ■ H ■ ■	25.2/55.6 34.4/75.9
S302 S402	63 63	1FK7060-5AF71-1 ■ ■ ■ 5-Z 1FK7060-5AF71-1 ■ ■ ■ 5-Z	E38 E48	G ■ ■ G ■ ■	H ■ ■ H ■ ■	34.4/75.9 43.6/96.1
Encoder systems:	Incremental encoder sin/cos 1 V _{pp} Absolute encoder EnDat 2048 pulses/rev. (shaft height 48 and higher) Absolute encoder EnDat 512 pulses/rev. (only shaft height 36) Basic abs. encoder EnDat 32 pulses/rev. (shaft height 48 and higher) Res., multi-pole (pole no. = pole no. motor) Resolver, 2-pole	A E H G S T				
Encoder systems:	Incremental encoder sin/cos 1 V _{pp} Absolute encoder EnDat 2048 pulses/rev. (shaft height 48 and higher) Absolute encoder EnDat 512 pulses/rev. (only shaft height 36) Basic abs. encoder EnDat 32 pulses/rev. (shaft height 48 and higher) Res., multi-pole (pole no. = pole no. motor) Resolver, 2-pole	D F L K U P				
Holding brake:	Motor without holding brake Motor with holding brake	U V				
Order codes for type, type of construction and mounting position, refer to page 3/86						. . .

AC motors

Geared motors

1FK7 geared servomotors Worm geared motors

Selection and ordering data

Output (S3-60%)	Output speed	Rated output torque	Max. permissible acceleration torque	Nominal ratio	Exact ratio	Cantilever force gearbox shaft extension	Overload factor
P_2 kW/HP	n_2 rpm	M_2 Nm/lb _f -ft	M_{2max} Nm/lb _f -ft	i_{nom}	i_{exact}	F_{Tperm} N/lb _f	f_B
2.11/2.83	325	61.9/45.6	126/92.9	9.2	1431/155	2194/493.23	1.4
2.08/2.79	171	116/85.5	217/159.9	17.5	351/20	2717/610.81	1.2
2.05/2.75	129 86	152/112 227/167.3	259/190.9 498/367	23 35	1863/80 2268/65	2986/671.28 4881/1097.30	1.1 1.5
1.92/2.57	51	360/265.3	561/413.5	59	117/2	5799/1303.67	1.0
1.94/2.60	43	430/316.9	791/583	70	279/4	7994/1797.13	1.2
1.93/2.59	171	108/79.6	217/159.9	17.5	351/20	2717/610.81	1.7
	173 129	107/78.9 142/104.7	373/274.9 259/190.9	17.5 23	1998/115 1863/80	3869/869.49 2986/671.28	3.0 1.6
	128 86	144/106.1 213/157	458/337.5 720/530.6	23 35	117/5 873/25	4273/960.61 6347/1426.87	2.7 2.9
1.79/2.40	51 43	335/246.9 399/294.1	561/413.5 609/448.8	59 70	117/2 2241/32	5799/1303.67 6157/1384.16	1.4 1.3
3.05/4.09	322	90.5/66.7	216/159.2	9.3	270/29	3143/706.58	1.6
3.01/4.04	173	166/122.3	373/274.9	17.5	1998/115	3869/869.79	1.5
3.03/4.06	172	168/123.8	557/410.5	17.5	612/35	5040/1133.04	2.2
2.98/4.00	128 128	222/163.6 222/163.6	458/337.5 685/504.8	23 23	117/5 117/5	4273/960.61 5554/1248.59	1.4 2.0
2.95/3.96	86	328/241.7	720/530.6	35	873/25	6347/1426.87	1.4
3.47/4.65	259	128/94.3	371/274.9	11.5	81/7	4392/987.37	1.9
3.44/4.61	172	191/140.8	557/410.5	17.5	612/35	5040/1133.04	1.9
4.50/6.03	259	166/122.3	371/273.4	11.5	81/7	4392/987.37	1.3
4.45/5.97	172	247/182	557/410.5	17.5	612/35	5040/1133.04	1.3

1FK7 geared servomotors Worm geared motors

Gearbox size	Motor frame size	Worm geared motors Order No.	Order codes			Total weight, approx. kg/lb
			Gearbox type	Type	Type of construction mounting position	
S202	63	1FK7063-5AF71-1 ■ ■ 5 - Z	E23	G ■ ■	H ■ ■	28.9/63.7
S202	63	1FK7063-5AF71-1 ■ ■ 5 - Z	E24	G ■ ■	H ■ ■	28.9/63.7
S202	63	1FK7063-5AF71-1 ■ ■ 5 - Z	E25	G ■ ■	H ■ ■	28.9/63.7
S302	63	1FK7063-5AF71-1 ■ ■ 5 - Z	E36	G ■ ■	H ■ ■	38.1/84.0
S302	63	1FK7063-5AF71-1 ■ ■ 5 - Z	E37	G ■ ■	H ■ ■	38.1/84.0
S402	63	1FK7063-5AF71-1 ■ ■ 5 - Z	E48	G ■ ■	H ■ ■	47.3/104.3
S202	80	1FK7080-5AF71-1 ■ ■ 5 - Z	E24	G ■ ■	H ■ ■	28.6/63.1
S302	80	1FK7080-5AF71-1 ■ ■ 5 - Z	E34	G ■ ■	H ■ ■	37.8/83.4
S202	80	1FK7080-5AF71-1 ■ ■ 5 - Z	E25	G ■ ■	H ■ ■	28.6/63.1
S302	80	1FK7080-5AF71-1 ■ ■ 5 - Z	E35	G ■ ■	H ■ ■	37.8/83.4
S402	80	1FK7080-5AF71-1 ■ ■ 5 - Z	E46	G ■ ■	H ■ ■	47/103.6
S302	80	1FK7080-5AF71-1 ■ ■ 5 - Z	E37	G ■ ■	H ■ ■	37.8/83.4
S302	80	1FK7080-5AF71-1 ■ ■ 5 - Z	E38	G ■ ■	H ■ ■	37.8/83.4
S302	80	1FK7083-5AF71-1 ■ ■ 5 - Z	E33	G ■ ■	H ■ ■	43/94.8
S302	80	1FK7083-5AF71-1 ■ ■ 5 - Z	E34	G ■ ■	H ■ ■	43/94.8
S402	80	1FK7083-5AF71-1 ■ ■ 5 - Z	E44	G ■ ■	H ■ ■	52.2/115.1
S302	80	1FK7083-5AF71-1 ■ ■ 5 - Z	E35	G ■ ■	H ■ ■	43/94.8
S402	80	1FK7083-5AF71-1 ■ ■ 5 - Z	E45	G ■ ■	H ■ ■	52.2/115.1
S402	80	1FK7083-5AF71-1 ■ ■ 5 - Z	E46	G ■ ■	H ■ ■	52.2/115.1
S402	100	1FK7100-5AF71-1 ■ ■ 5 - Z	E43	G ■ ■	H ■ ■	54.4/120.2
S402	100	1FK7100-5AF71-1 ■ ■ 5 - Z	E44	G ■ ■	H ■ ■	54.4/120.2
S402	100	1FK7101-5AF71-1 ■ ■ 5 - Z	E43	G ■ ■	H ■ ■	60/132.3
S402	100	1FK7101-5AF71-1 ■ ■ 5 - Z	E44	G ■ ■	H ■ ■	60/132.3
Encoder systems: Motors without DRIVE-CLiQ interface	Incremental encoder sin/cos 1 V _{pp} Absolute encoder EnDat 2048 pulses/rev. (shaft height 48 and higher) Absolute encoder EnDat 512 pulses/rev. (only shaft height 36) Basic abs. encoder EnDat 32 pulses/rev. (shaft height 48 and higher) Res., multi-pole (pole no. = pole no. motor) Resolver, 2-pole	A E H G S T				
Encoder systems: Motors with DRIVE-CLiQ interface	Incremental encoder sin/cos 1 V _{pp} Absolute encoder EnDat 2048 pulses/rev. (shaft height 48 and higher) Absolute encoder EnDat 512 pulses/rev. (only shaft height 36) Basic abs. encoder EnDat 32 pulses/rev. (shaft height 48 and higher) Res., multi-pole (pole no. = pole no. motor) Resolver, 2-pole	D F L K U P				
Holding brake:	Motor without holding brake Motor with holding brake	U V				

Order codes for type, type of construction and mounting position, refer to page 3/86

AC motors

Geared motors

1FK7 geared servomotors

Selection and ordering data

Order codes for 1FK7 geared servomotors

Order no. for geared motor + order codes

1FK7...-5A.71-1..5-Z □ □ □ G □ □ H □ □

1st order code, Gear type

- Bevel gear unit K 102 to K 813
- Offset shaft gear unit F 202 to F 602
- Helical gear unit C 002 to C 812
- Worm gear unit S 002 to S 402

For complete order code for gear type, see selection and ordering data on pages 3/64 to 3/85

B
C
D
E

G 1
G 2
G 3
G 5
G 6

H 1
H 2
H 3
H 4
H 5
H 6
H 7
H 8

2nd order code, 1st and 2nd positions: Type

- Foot-mounted
- Tapped hole group
- Flange (round)
- Foot-mounted and flange (round)
- Foot-mounted and tapped hole group

G 1
G 2
G 3
G 5
G 6

2nd order code, 3rd position: Gear unit shaft end

- | | | | |
|-------------------------------|---|---|---|
| Helical gear unit: | Offset shaft gear unit: | For bevel and worm gearboxes: | |
| • Solid shaft with fitted key | • Solid shaft with fitted key, gearbox side 5 | • Solid shaft with fitted key, gearbox side 4 | 1 |
| | • Hollow shaft with keyway, insertion gearbox side 5 | • Hollow shaft with keyway, insertion gearbox side 4 | 3 |
| | • Hollow shaft with tensioning element, shrink disk, side 6, insertion gearbox side 5 | • Hollow shaft with tensioning element, shrink disk, side 4, insertion gearbox side 3 | 4 |
| | | • Solid shaft with fitted key, gearbox side 3 | 5 |
| | | • Hollow shaft with keyway, insertion gearbox side 3 | 7 |
| | | • Hollow shaft with tensioning element, shrink disk, side 3, insertion gearbox side 4 | 8 |

3rd order code, 1st and 2nd positions: Type of construction/mounting position

Type of construction for

- Helical gear unit:
- IM B3 / IM B5 / IM B14 / IM B34 / IM B35
 - IM B7
 - IM B8
 - IM B6
 - IM V1
 - IM V3 / IM V6 / IM V19
 - IM V5
 - IM V18

Mounting position for

- Offset shaft, bevel and worm gearboxes:
- EL 1
 - EL 2
 - EL 3
 - EL 4
 - EL 5
 - EL 6
 -
 -

H 1
H 2
H 3
H 4
H 5
H 6
H 7
H 8

3rd order code, 3rd position: Connector attachment position

- Connector position on gearbox side 2
- Connector position on gearbox side 4
- Connector position on gearbox side 1
- Connector position on gearbox side 3

1
2
3
4

3

Selection and ordering data

Order codes for 1FK7 geared servomotors

Order no. geared motor + order codes

4th order code, torque bracket for bevel (K) and worm gear units (S)			Q	□	□	and	G	2	or	□ ¹⁾	G	2	□ ¹⁾
Torque bracket position			Gear unit type and size										
Torque bracket	Side 1, eye side 4	K 102, S 102	Q	1	2	G	2	3	G	2	8		
	Side 1, eye side 3	K 102, S 102	Q	1	3	G	2	7	G	2	4		
	Side 5, eye side 4	K 102, S 102	Q	1	4	G	2	3	G	2	8		
	Side 5, eye side 3	K 102, S 102	Q	1	5	G	2	7	G	2	4		
	Side 2, eye side 4	K 102	Q	1	6	G	2	3	G	2	8		
	Side 2, eye side 3	K 102	Q	1	7	G	2	7	G	2	4		
Torque bracket	Side 1, eye side 4	K 202, S 202	Q	2	2	G	2	3	G	2	8		
	Side 1, eye side 3	K 202, S 202	Q	2	3	G	2	7	G	2	4		
	Side 5, eye side 4	K 202, S 202	Q	2	4	G	2	3	G	2	8		
	Side 5, eye side 3	K 202, S 202	Q	2	5	G	2	7	G	2	4		
Torque bracket	Side 1, eye side 4	K 302, S 302	Q	3	2	G	2	3	G	2	8		
	Side 1, eye side 3	K 302, S 302	Q	3	3	G	2	7	G	2	4		
	Side 5, eye side 4	K 302, S 302	Q	3	4	G	2	3	G	2	8		
	Side 5, eye side 3	K 302, S 302	Q	3	5	G	2	7	G	2	4		
Torque bracket	Side 1, eye side 4	K 402, S 402	Q	4	2	G	2	3	G	2	8		
	Side 1, eye side 3	K 402, S 402	Q	4	3	G	2	7	G	2	4		
	Side 5, eye side 4	K 402, S 402	Q	4	4	G	2	3	G	2	8		
	Side 5, eye side 3	K 402, S 402	Q	4	5	G	2	7	G	2	4		
Torque bracket	Side 1, eye side 4	K 513	Q	5	2	G	2	3	G	2	8		
	Side 1, eye side 3	K 513	Q	5	3	G	2	7	G	2	4		
	Side 5, eye side 4	K 513	Q	5	4	G	2	3	G	2	8		
	Side 5, eye side 3	K 513	Q	5	5	G	2	7	G	2	4		
Torque bracket	Side 1, eye side 4	K 613	Q	6	2	G	2	3	G	2	8		
	Side 1, eye side 3	K 613	Q	6	3	G	2	7	G	2	4		
	Side 5, eye side 4	K 613	Q	6	4	G	2	3	G	2	8		
	Side 5, eye side 3	K 613	Q	6	5	G	2	7	G	2	4		
Torque bracket	Side 1, eye side 4	K 713	Q	7	2	G	2	3	G	2	8		
	Side 1, eye side 3	K 713	Q	7	3	G	2	7	G	2	4		
	Side 5, eye side 4	K 713	Q	7	4	G	2	3	G	2	8		
	Side 5, eye side 3	K 713	Q	7	5	G	2	7	G	2	4		
Torque bracket	Side 1, eye side 4	K 813	Q	8	2	G	2	3	G	2	8		
	Side 1, eye side 3	K 813	Q	8	3	G	2	7	G	2	4		
	Side 5, eye side 4	K 813	Q	8	4	G	2	3	G	2	8		
	Side 5, eye side 3	K 813	Q	8	5	G	2	7	G	2	4		

1) Options **Q12** to **Q85** can be combined only with the following order codes:
B.. or **E..** with **G23** or **G24** or **G27** or **G28**



AC motors

Geared motors

1FK7 geared servomotors

Selection and ordering data

5th order code, other options

- Paint finish, matt black RAL 9005
- Paint finish, cream white RAL 9001
- Paint finish, reseda green RAL 6011
- Paint finish, pebble gray RAL 7032
- Paint finish, sky blue RAL 5015
- Paint finish, light ivory RAL 1015
- Paint finish, ash gray RAL 7000
- Paint finish, white aluminum RAL 9006
- Paint finish, gentian blue RAL 5010
- Paint finish, pure orange RAL 2004
- Food-grade gear oil (1FK7... - 5A.71 - 1...7 - Z)

X	0	1
X	0	2
X	0	3
X	0	4
X	0	5
X	0	6
X	0	7
X	0	8
X	1	2
X	1	9
Q	9	0

3

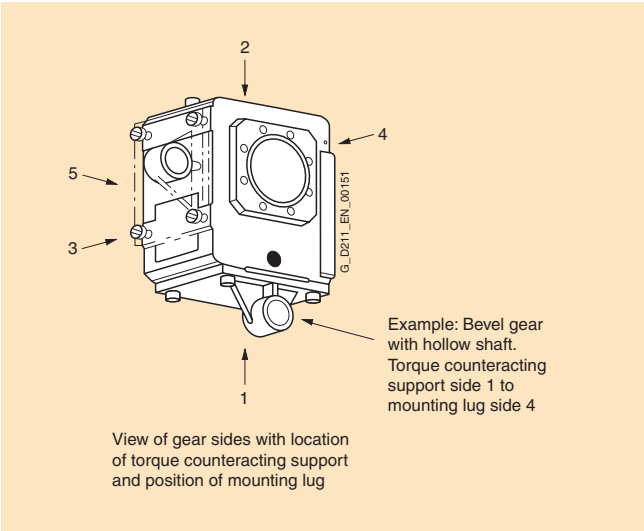

Overview of possible combinations of option Gxx with Hxx and Qxx

Description of options	Gear type				Permissible H options		
	Helical	Offset shaft	Bevel	Worm	Permissible H option for helical	Permissible H option for offset shaft	Permissible H option for bevel and worm
	Order code for option Gxx				Order code for option Hxx		
G11 Foot-mounted, solid shaft with fitted key	✓				H1x to H4x		
G13 Footed-mounted, hollow shaft with keyway (insertion gearbox side 4)							
G14 Footed-mounted, hollow shaft with shrink disk (insertion gearbox side 4)							
G15 Foot-mounted, solid shaft with fitted key (gearbox side 3)							
G17 Footed-mounted, hollow shaft with keyway (insertion gearbox side 3)							
G18 Footed-mounted, hollow shaft with shrink disk (gearbox side 3)							
G21 Tapped hole group, solid shaft with keyway (gearbox side 4 for bevel and worm)	✓		✓	✓ ¹⁾	H1x, H6x, H8x		H1x to H6x
G23 Tapped hole group, solid shaft with keyway (insertion gearbox side 5 for offset shaft, insertion gearbox side 4 for bevel and worm)		✓	✓	✓ ¹⁾		H1x to H6x	H1x to H6x, Qxx
G24 Tapped hole group, hollow shaft with tensioning element (shrink disk on gearbox side 6 and insertion side 5 for offset shaft; shrink disk on gearbox side 4 and insertion side 3 for bevel and worm)		✓	✓	✓ ¹⁾			
G25 Tapped hole group, solid shaft with fitted key (gearbox side 3)			✓	✓ ¹⁾			H1x to H6x
G27 Tapped hole group, hollow shaft with fitted key (insertion gearbox side 3)			✓	✓ ¹⁾			H1x to H6x, Qxx
G28 Tapped hole group, hollow shaft with tensioning element (shrink disk on gearbox side 3 and insertion side 4 for bevel and worm)			✓	✓ ¹⁾			
G31 Flange (round), solid shaft with fitted key (gearbox side 5 for offset shaft; side 4 for bevel and worm)	✓	✓	✓	✓ ¹⁾	H1x, H5x, H6x	H1x to H6x	H1x to H6x
G33 Flange (round), hollow shaft with keyway (insertion gearbox side 4)		✓	✓	✓ ¹⁾			
G34 Flange (round), hollow shaft with tensioning element, shrink disk on gearbox side 6 and insertion side 5 for offset shaft; shrink disk on gearbox side 4 and insertion side 3 for bevel and worm)		✓	✓	✓ ¹⁾			
G35 Flange (round), solid shaft with fitted key (gearbox side 3)			✓	✓ ¹⁾			
G37 Flange (round), hollow shaft with keyway (insertion gearbox side 3)			✓	✓ ¹⁾			
G38 Flange (round), hollow shaft with tensioning element (shrink disk on gearbox side 3 and insertion side 4 for bevel and worm)			✓	✓ ¹⁾			

Qxx: New options, torque bracket
H2x: Construction type IM B7 for helical gearboxes

¹⁾ Not for worm gear size S002 (E0x).

AC motors

Geared motors

1FK7 geared servomotors

Overview of possible combinations of option Gxx with Hxx and Qxx

Description of options	Gear type				Permissible H options		
	Helical	Offset shaft	Bevel	Worm	Permissible H option for helical	Permissible H option for offset shaft	Permissible H option for bevel and worm
G51 Foot-mounted and flange (round), solid shaft with fitted key (gearbox side 4 for bevel and worm)	✓ ¹⁾		✓ ²⁾	✓	H1x, H2x		H1x to H6x
G53 Foot-mounted and flange (round), hollow shaft with keyway (insertion gearbox side 4)			✓	✓			
G54 Foot-mounted and flange (round), hollow shaft with tensioning element (shrink disk on gearbox side 4 and insertion side 4 for bevel and worm)			✓	✓			
G55 Foot-mounted and flange (round), solid shaft with fitted key (gearbox side 3)			✓	✓			
G57 Foot-mounted and flange (round), hollow shaft with keyway (insertion gearbox side 3)			✓	✓			
G58 Foot-mounted and flange (round), hollow shaft with tensioning element (shrink disk on gearbox side 3 and insertion side 4 for bevel and worm)			✓	✓			
G61 Foot-mounted and tapped hole group, solid shaft with fitted key (gearbox side 4 for bevel and worm)	✓		✓	✓	H1x, H2x		H1x to H6x
G63 Foot-mounted and tapped hole group, hollow shaft with keyway (insertion gearbox side 4)			✓	✓			
G64 Foot-mounted and tapped hole group, hollow shaft with tensioning element (shrink disk on gearbox side 4 and insertion side 4 for bevel and worm)			✓	✓			
G65 Foot-mounted and tapped hole group, solid shaft with fitted key (gearbox side 3)			✓	✓			
G67 Foot-mounted and tapped hole group, hollow shaft with keyway (insertion gearbox side 3)			✓	✓			
G68 Foot-mounted and tapped hole group, hollow shaft with tensioning element (shrink disk on gearbox side 3 and insertion side 4 for bevel and worm)			✓	✓			

Qxx: New options, torque bracket
H2x: Construction type IM B7 for helical gearboxes

¹⁾ The flange diameter for helical gearboxes with foot mounting and flange is one diameter grade smaller in each case than the diameter for helical units with flange only (without foot mounting).

²⁾ Only for 1FK706. to 1FK10. with gear unit size K 513 to K 813 (B5x to B8x). These values refer to $n = 2500$ rpm.

Selection and ordering data

Helical geared motors - types of construction

IM B 3

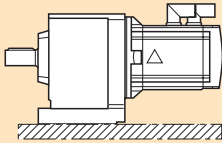

IM B 5

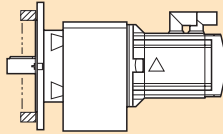

IM B 14

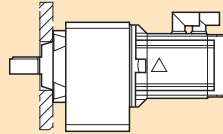

IM B 34

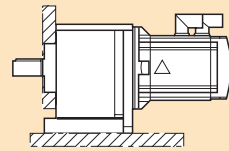

IM B 35

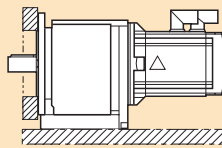

IM B 6

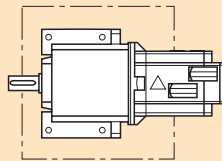

IM B 7

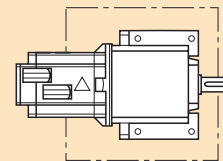

IM B 8

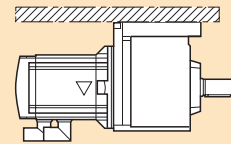

G_DA65_XX_00170

IM V 1

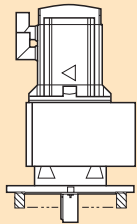

IM V 18

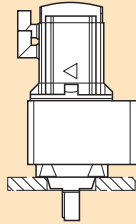

IM V 19

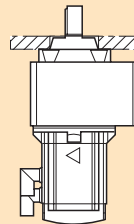

IM V 3

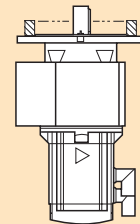

IM V 5

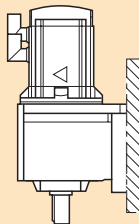

IM V 6

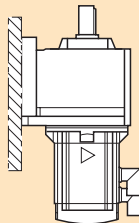

AC motors

Geared motors

1FK7 geared servomotors

Selection and ordering data

Offset shaft geared motors - mounting positions EL 1 to EL 6

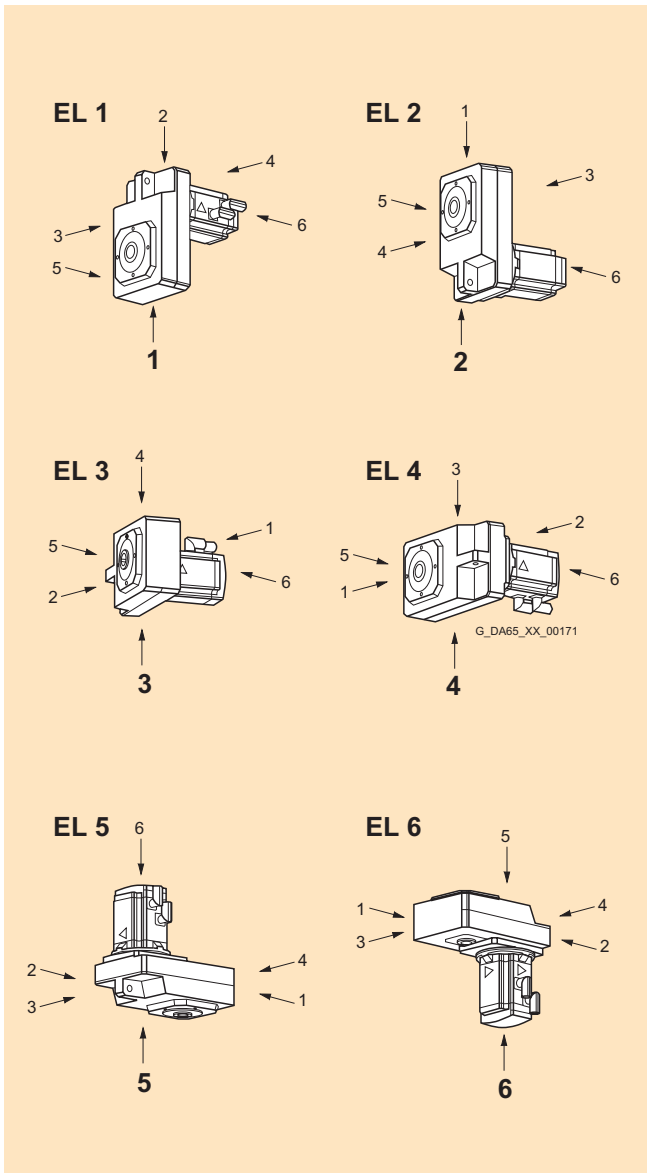

3

Selection and ordering data

Bevel geared motors - mounting positions EL 1 to EL 6

Gearbox sizes K1 to K4

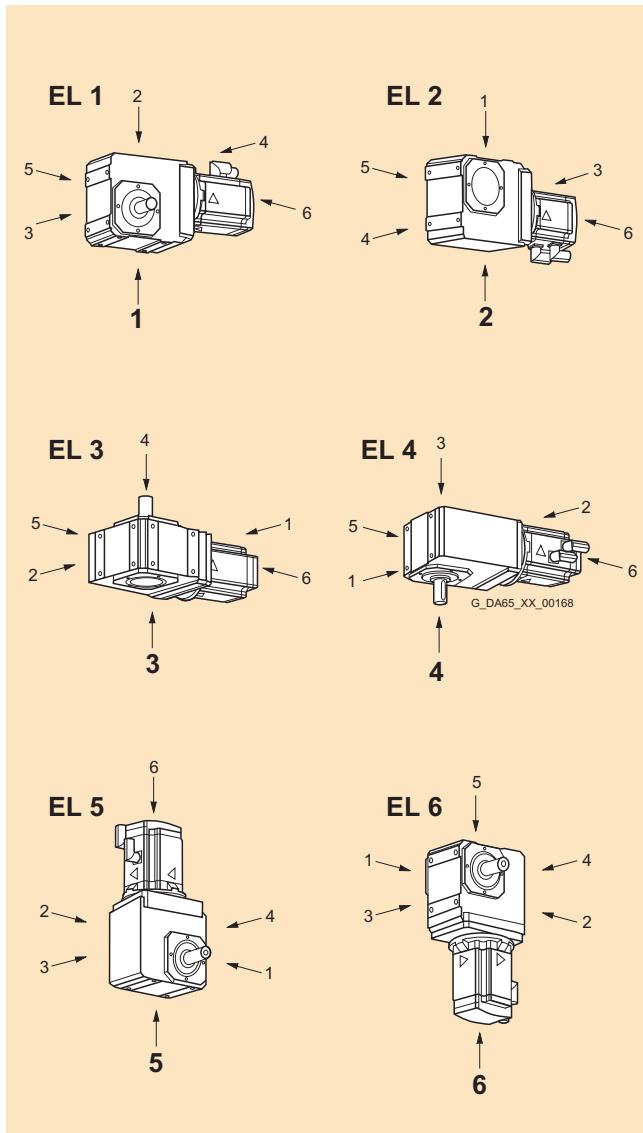

Gearbox sizes K5 to K8

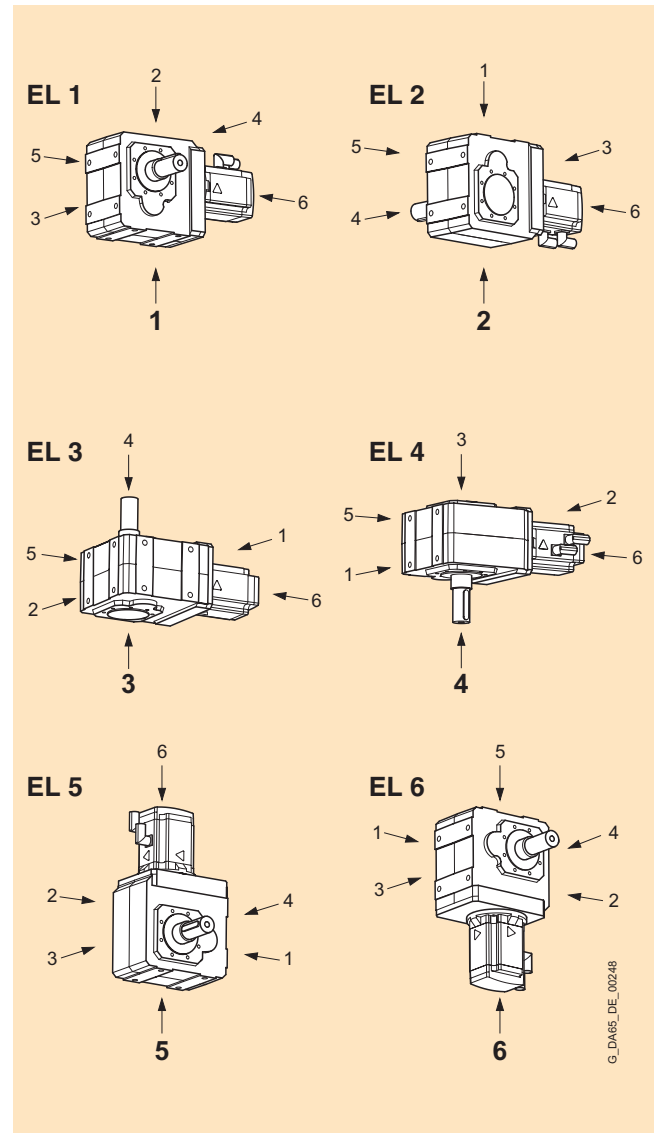

AC motors

Geared motors

1FK7 geared servomotors

Selection and ordering data

Worm geared motors - mounting positions EL 1 to EL 6

Gearbox size S0

Gearbox sizes S1 to S4

3

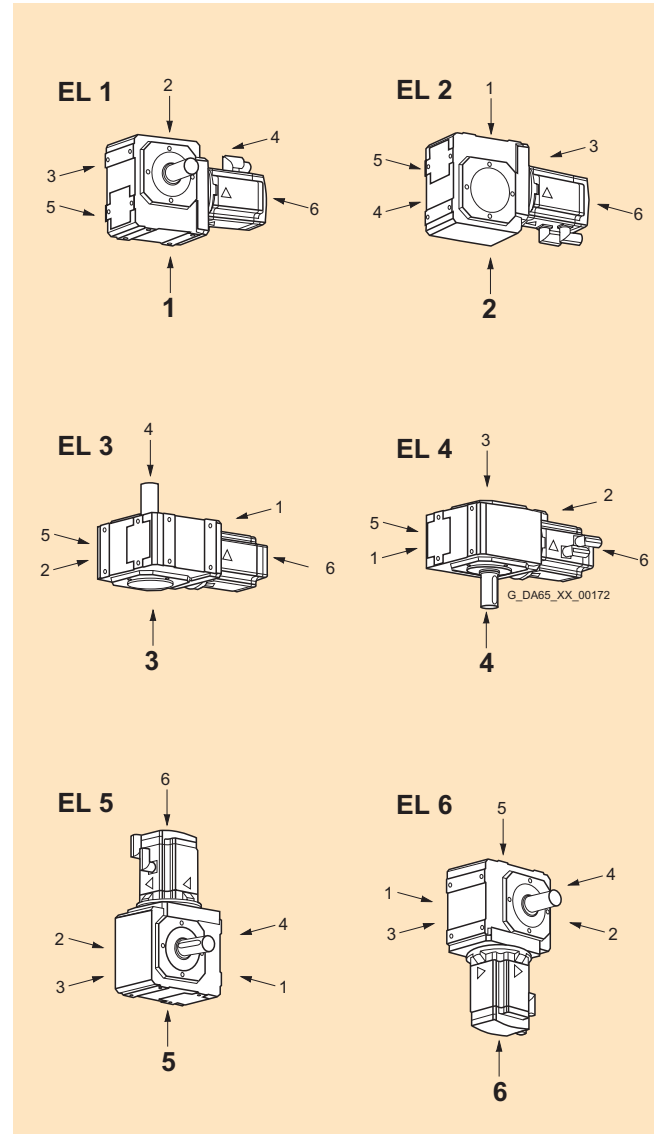
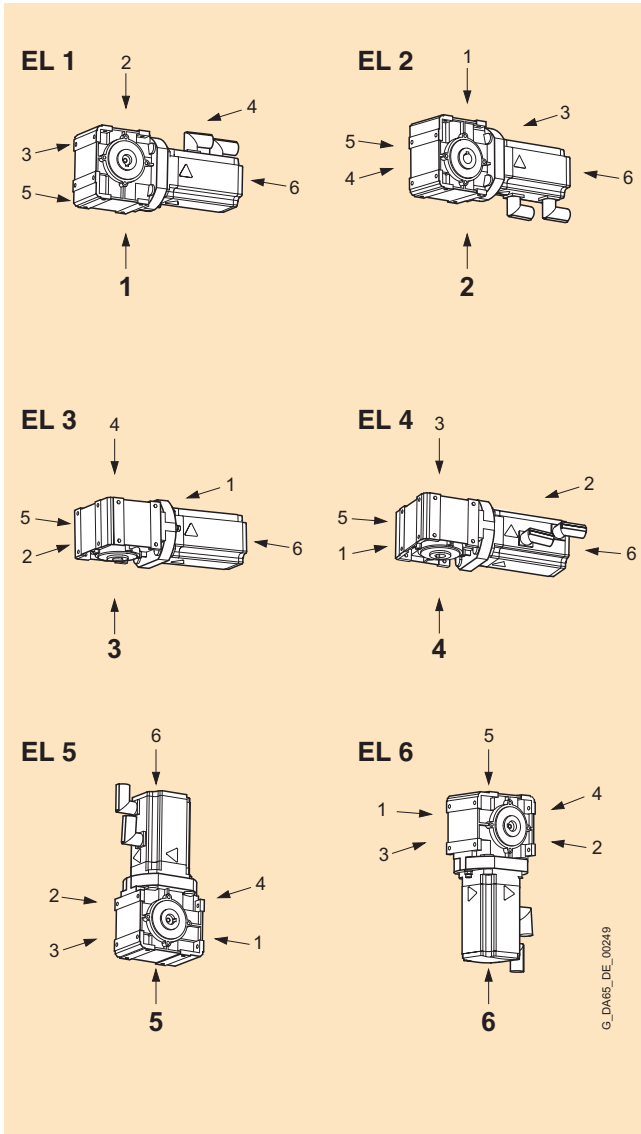

Selection and ordering data

Connector mounting position

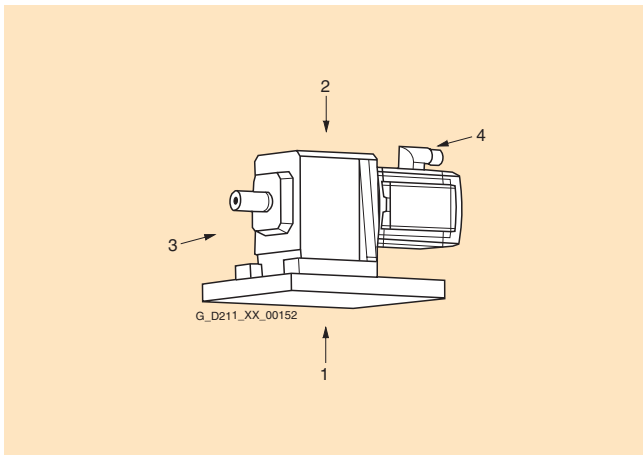

AC motors

Synchronous motors

1FS6 motors, explosion-protected
Natural cooling



Overview



1FS6 explosion-protected synchronous servomotors

1FS6 motors are permanent-magnet synchronous motors for use in Zone 1 hazardous areas.

They are designed in compliance with the EEx de IIC T3 type of protection, certified in accordance with ATEX guidelines 94/9/EG, and also have CSA approval for Class 1, Zone 1, Temperature Class T3 (CAN/CSA-79-1-95 "Flameproof enclosure").

In addition to compliance with the applicable standards and regulations (ATEX) for potentially explosive environments, these motors also conform to the following European guidelines:

- EN 50014
General Conditions for Electrical Equipment for Potentially Explosive Atmospheres
- EN 50018
Standard referring to EEx d type of protection
- EN 50019
Standard referring to EEx e type of protection
- EN 50021
Standard referring to Ex nA type of protection

1FS6 motors can be combined with the SINAMICS S120 drive system to create a powerful, high-performance system. The integrated encoder systems for speed and position control can be selected.

The motors are designed for operation without external cooling as the heat is dissipated through the motor surface.

Benefits

- Winding insulation for Thermal Class H
- High cantilever force loading
- Naturally cooled motors with terminal box for power connection
- Additional terminal box for connection of encoder system and temperature sensors
- Monitoring of motor temperature with KTY 84-130 and PTC thermistor (triggering device must be certified according to test mark PTB 3x PTC-01 ATEX 3218, e.g. SIMIREL 3RN10 thermistor-motor protection)

Applications

1FS6 motors with explosion protection are suitable for operation in Zone 1 hazardous areas in any industrial sector or machine type, including,

- Flexographic printing and platen-printing machines
- Filling plants with potentially explosive vapors
- Film coating plants



Technical data

Type of motor	AC servomotor (permanent-magnet synchronous motor)
Magnet material	Rare-earth magnet material
Insulation of the stator winding in accordance with EN 60034-1 (IEC 60034-1)	Thermal Class H for a winding temperature rise of $\Delta T = 100$ K at an ambient temperature of 40 °C ($+104$ °F).
Type in accordance with EN 60034-7 (IEC 60034-7)	IM B5 (1FS6074 and 1FS6096) IM B35 (1FS6115 and 1FS6134)
Degree of protection in accordance with EN 60034-5 (IEC 60034-5)	IP64
Cooling	Natural cooling
Temperature monitoring	3 PTC thermistors + KTY 84 temperature sensor in stator winding
Paint finish	Anthracite RAL 7016
Shaft end on the drive end in accordance with DIN 748-3 (IEC 60072-1)	Plain shaft
Radial eccentricity, concentricity and axial eccentricity in accordance with DIN 42955 (IEC 60072-1)	Tolerance N (normal)
Vibration severity in accordance with EN 60034-14 (IEC 60034-14)	Grade N (normal)
Bearings	Permanently lubricated deep-groove ball bearings
Built-in encoder systems	<ul style="list-style-type: none"> • Incremental encoder sin/cos 1 V_{pp} 2048 S/R • Absolute encoder EnDat 2048 S/R ¹⁾
Connection	2 terminal boxes
Options	<ul style="list-style-type: none"> • Shaft extension with fitted key and keyway (half-key balancing) • Rotational accuracy, concentricity and axial eccentricity Tolerance R • IP65 degree of protection with radial shaft seal

Notice

A PTC thermistor triggering device, such as SIMIREL 3RN10 thermistor motor protection, is mandatory for operating these machines in potentially explosive environments. The connection cables must be able to withstand temperatures of at least $+100$ °C ($+212$ °F).

The motors can be connected to SINAMICS S120 converters only by way of a terminal box. It is not permissible to use connector plugs in Zone 1 areas. Encoders must be connected by means of an SMC20 Sensor Module Cabinet-Mounted.

Characteristics

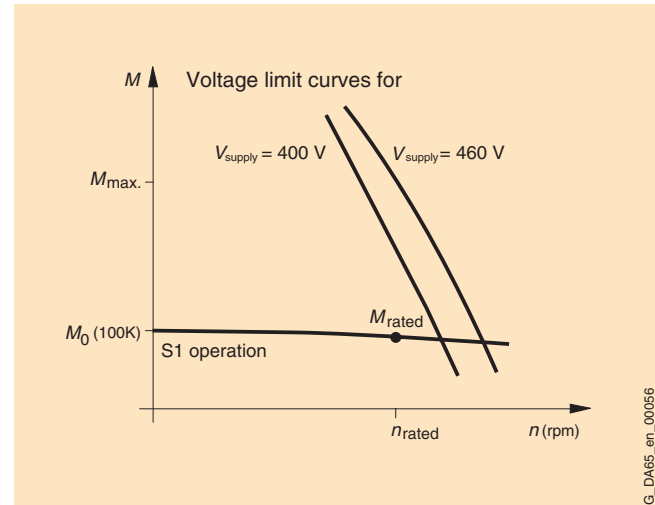

Speed-torque characteristic

G_DAE5_en_00056

¹⁾ If the absolute encoder is used, M_{rated} is reduced by 10%.

AC motors

Synchronous motors

1FS6 motors, explosion-protected
Natural cooling



Selection and ordering data

Rated speed	Shaft height	Rated power	Rated torque ¹⁾	Rated current	Static torque	1FS6 synchronous motors Explosion-proof Natural cooling	Number of pole pairs	Rotor moment of inertia (without brake)	Weight (without brake)
n_{rated}		P_{rated} at $\Delta T=100\text{ K}$	M_{rated} at $\Delta T=100\text{ K}$	I_{rated} at $\Delta T=100\text{ K}$	M_0 at $\Delta T=100\text{ K}$	Order No. Core type		J	
rpm	SH	kW/HP	Nm/lb _f -ft	A	Nm/lb _f -ft			$10^{-4}\text{ kgm}^2/\text{lb}_f\text{-in-s}^2$	kg/lb
1500	112	5.8/7.8	37/27.3	13	40/29.5	1FS6115-8AB73-■■■■■	4	168/0.1487	87/191.84
	132	10.7/14.4	68/50.1	22	76/56	1FS6134-6AB73-■■■■■	3	547/0.4841	149/328.55
2000	71	1.5/2.0	7.2/5.3	3.4	7.6/5.6	1FS6074-6AC71-■■■■■	3	13/0.0115	29/63.95
	90	4.2/5.6	20/14.7	9.8	22/16.2	1FS6096-8AC71-■■■■■	4	66.5/0.0589	55/121.28
	112	7.1/9.5	34/25.1	16	40/29.5	1FS6115-8AC73-■■■■■	4	168/0.1487	87/191.84
	132	12.4/16.6	59/43.5	24	76/56	1FS6134-6AC73-■■■■■	3	547/0.4841	149/328.55
	3000	71	2/2.7	6.3/4.6	4.4	7.6/5.6	1FS6074-6AF71-■■■■■	3	13/0.0115
3000	90	5.3/7.1	17/12.5	12	22/16.2	1FS6096-8AF71-■■■■■	4	66.5/0.0589	55/121.28
	112	8.8/11.8	28/20.6	20	40/29.5	1FS6115-8AF73-■■■■■	4	168/0.1487	87/191.84
	4500	71	2.1/2.8	4.5/3.3	5	7.6/5.6	1FS6074-6AH71-■■■■■	3	13/0.0115
4500	90	5.2/7.0	11/8.1	11.5	22/16.2	1FS6096-8AH71-■■■■■	4	66.5/0.0589	55/121.28
6000	71	1.2/1.6	1.9/1.4	3.2	7.6/5.6	1FS6074-6AK71-■■■■■	3	13/0.0115	29/63.95

Type:	IM B5 (only for 1FS607 and 1FS609) IM B35 (only for 1FS611 and 1FS613)	1 3
Terminal box for power and encoder connection:	Cable entry transverse right Cable entry transverse left Cable entry axial NDE Cable entry axial DE	5 6 7 8
Encoder system without DRIVE-CLiQ interface:	Incremental encoder sin/cos 1 V_{pp} , 2048 pulses/rev. Absolute encoder EnDat 2048 pulses/rev. ¹⁾	A E
Shaft extension: Plain shaft with fitted key and keyway Plain shaft with fitted key and keyway	Radial eccentricity tolerance: N N R R	G A K D
Vibration severity grade: N N	Degree of protection: IP64 IP65 with radial shaft seal	0 1

3



Selection and ordering data

Motor type (continued)	Static current I_0 at $\Delta T=100\text{ K}$ A	SINAMICS Motor Module Rated current		Power cable with complete shield Motor connection via terminal box	
		I_{rated} A	Order No. For complete Order No., see "SINAMICS S120"	Cable cross section Motor ²⁾ mm ²	Order no. Pre-assembled cable No connector, prepared wire ends
1FS6115-8AB73-....	13	18	6SL312 ■-■TE21-8 AA .	4 x 1.5	6FX5002-5XA00-....
1FS6134-6AB73-....	22	30	6SL312 ■-1TE23-0 AA .	4 x 4	6FX5002-5XA20-....
1FS6074-6AC71-....	3.4	5	6SL312 ■-■TE15-0 AA .	4 x 1.5	6FX5002-5XA00-....
1FS6096-8AC71-....	9.2	18	6SL312 ■-■TE21-8 AA .	4 x 1.5	6FX5002-5XA00-....
1FS6115-8AC73-....	18	18	6SL312 ■-■TE21-8 AA .	4 x 2.5	6FX5002-5XA10-....
1FS6134-6AC73-....	29	30	6SL312 ■-1TE23-0 AA .	4 x 4	6FX5002-5XA20-....
1FS6074-6AF71-....	4.8	5	6SL312 ■-■TE15-0 AA .	4 x 1.5	6FX5002-5XA00-....
1FS6096-8AF71-....	14	18	6SL312 ■-■TE21-8 AA .	4 x 1.5	6FX5002-5XA00-....
1FS6115-8AF73-....	26	30	6SL312 ■-1TE23-0 AA .	4 x 4	6FX5002-5XA20-....
1FS6074-6AH71-....	7.2	5	6SL312 ■-■TE15-0 AA .	4 x 1.5	6FX5002-5XA00-....
1FS6096-8AH71-....	19	18	6SL312 ■-■TE21-8 AA .	4 x 1.5	6FX5002-5XA00-....
1FS6074-6AK71-....	9.6	5	6SL312 ■-■TE15-0 AA .	4 x 1.5	6FX5002-5XA00-....

Cooling:

Internal air cooling
External air cooling

0
1

Motor Module:

Single Motor Module
Double Motor Module

1
2

For length code as well as power and signal cables, see "MOTION-CONNECT cables and connections".

Ordering data for signal cables

Pre-assembled signal cable with complete shield	Order No.
• Incremental encoder sin/cos 1 V_{pp}	6FX5002-2XA00-....
• EnDat absolute encoder	6FX5002-2XQ10-....
• PTC thermistor (for connection to 3RN10 triggering device)	6FX5002-1XA04-....

¹⁾ If the absolute encoder is used, M_{rated} is reduced by 10%.

²⁾ The current carrying capacity of the power cables corresponds to IEC 60204-1 for type of routing C under continuous operating conditions with an ambient air temperature of +40 °C (+104 °F), designed for I_{rated} (100 K), PVC/PUR-insulated cable.

AC motors

Synchronous motors

1FW3 torque motors Water cooling

Overview

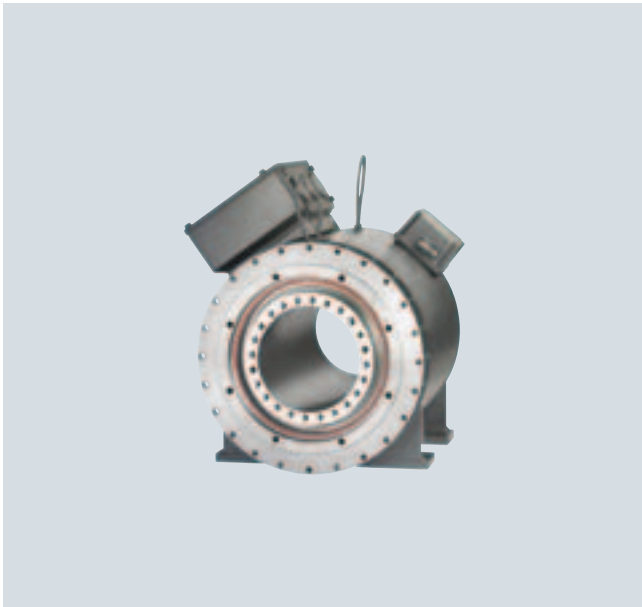

1FW3 torque motors

1FW3 torque motors are liquid-cooled, high-pole (slow running) permanent-magnet synchronous motors with hollow-shaft rotor. The operating characteristics are similar to those of regular synchronous motors.

1FW3 torque motors are supplied as fully assembled units. The range includes 3 outer diameters with various shaft lengths. The stator and the rotor in shaft heights 150 and 200 have a flange with centering surfaces and tapped holes per construction type IM B14 at the drive end (A end) allowing them to be integrated into the customer's machine. In shaft height 280, the flange is designed with centering surfaces and through-holes per construction type IM B35.

1FW3 torque motors can be combined with the SINAMICS S120 drive system to create a powerful, high-performance system. The integrated encoder systems for speed and position control can be selected.

Benefits

- High torque for a compact design and small size
- High overload capability
- No elasticity in the drive train
- No torsional backlash
- High availability, since there are no mechanical transmission elements subject to wear in the drive train
- Low moment of inertia
- Direct coupling to the machine using flanges
- Hollow-shaft rotor design allows for flexible installation concepts
- Energy savings through reduction in mechanical losses

Applications

The 1FW3 series was developed as a direct drive. This is a compact drive unit where the mechanical motor power is transferred directly to the driven machine without any mechanical transmission elements.

- Extruder main drives
- Worm drives for injection molding machines
- Pull-roll drives for foil-stretching machines
- Stretch and calender rollers, continuous casting and rolling, chill roller stands
- Dynamic positioning tasks, e.g. rotary tables, cyclic conveyor belts
- Substitute for hydraulic motors
- Roller drives in paper machines
- Cross-cutter drives for continuous material webs, e.g. paper, textiles, sheet metal, etc.
- Wire-drawing machines
- Choppers

Technical data

Type of motor	Permanent-magnet synchronous motor
Magnet material	Rare-earth magnet material
Insulation of the stator winding in accordance with EN 60034-1 (IEC 60034-1)	Thermal Class F for a winding temperature rise of $\Delta T = 100$ K at a coolant (water) inlet temperature of +25 °C (104 °F)
Type in accordance with EN 60034-7 (IEC 60034-7)	Shaft height 150: IM B14, IM V14 Shaft height 200: IM B14, IM V14 Shaft height 280: IM B35
Degree of protection in accordance with EN 60034-5 (IEC 60034-5)	IP54
Cooling in accordance with EN 60034-6 (IEC 60034-6)	Water cooling
Thermal motor protection in accordance with EN 60034-11 (IEC 60034-11)	KTY 84 temperature sensor in stator winding
Paint finish	Anthracite (RAL 7016)
2nd rating plate	Enclosed separately
Shaft extension in accordance with DIN 748-3 (IEC 60072-1)	Hollow shaft Inside diameter for SH 150: $d_i = 152$ mm (5.98 in) Inside diameter for SH 200: $d_i = 152$ mm (5.98 in) Inside diameter for SH 280: $d_i = 250$ mm (9.84 in)
Radial eccentricity, concentricity, and axial eccentricity in accordance with DIN 42955 (IEC 60072-1)	Tolerance N (normal)
Vibration severity in accordance with EN 60034-14 (IEC 60034-14)	Grade N (normal)
Sound pressure level in accordance with DIN EN ISO 1680	70 dB(A) + 3 dB(A) tolerance with 4 kHz rated pulse frequency 73 dB(A) + 3 dB(A) tolerance with 2 kHz rated pulse frequency
Flange accuracy	Grade N (normal)
Shock stressing	Maximum permissible radial acceleration 50 m/s ² (164.05 ft/s ²) (not in operational state)
Bearings	Roller bearings with permanent grease lubrication (lubrication over the bearing lifetime = 20000 h)
Built-in encoder systems	<ul style="list-style-type: none"> • 8-pole resolver, belt-mounted • Incremental encoder sin/cos 1 V_{pp}, 2048 pulses/rev., belt-mounted • Multiturn absolute encoder EnDat, 2048 pulses/rev., belt-mounted or coaxially mounted at NDE • Singleturn absolute encoder EnDat, 2048 pulses/rev., coaxially mounted at NDE
Connection	Terminal box for power cable Connector for encoder signals and KTY 84
Options	<ul style="list-style-type: none"> • Motor protection through PTC thermistor with 3 embedded temperature sensors for tripping • Shaft cover at NDE • Regreasing device • Non-standard paint finish • Non-standard rated speeds (enquiry necessary)

Options

Order code	Option description
A11	Motor protection by PTC thermistors
X01	Paint finish, jet black, RAL 9005
X02	Paint finish, cream white, RAL 9001
X03	Paint finish, reseda green, RAL 6011
X04	Paint finish, pebble gray, RAL 7032
X05	Paint finish, sky blue, RAL 5015
X06	Paint finish, light ivory, RAL 1015
K40	Re-lubrication devices at DE and NDE
T20	Shaft cover at NDE (not required with coaxially mounted encoder)

AC motors

Synchronous motors

1FW3 torque motors Water cooling

Selection and ordering data

Rated speed	Shaft height	Rated power	Rated torque	Rated current	Static torque	1FW3 torque motors Water cooling	Number of pole pairs	Rotor moment of inertia	Weight, approx.
n_{rated}	SH	P_{rated} at $\Delta T=100\text{ K}$	M_{rated} at $\Delta T=100\text{ K}$	I_{rated} at $\Delta T=100\text{ K}$	M_0 at $\Delta T=100\text{ K}$	Order No.		J	m
rpm		kW/HP	Nm/lb _f -ft	A	Nm/lb _f -ft			kgm ² / lb _f -in-s ²	kg/lb

Line voltage 400 V 3 AC Active Line Module ²⁾

Rated speed	Shaft height	Rated power	Rated torque	Rated current	Static torque	Order No.	Number of pole pairs	Rotor moment of inertia	Weight, approx.
150	200	4.7/6.3	300/221.1	13	315/232.2	1FW3201-1 ■ E ■ 2 - ■ AA 0	14	0.22/ 1.947	127/ 280.04
		7.9/10.6	500/368.5	21	525/386.9	1FW3202-1 ■ E ■ 2 - ■ AA 0	14	0.36/ 3.186	156/ 343.98
		11.8/15.8	750/552.8	30	790/582.2	1FW3203-1 ■ E ■ 2 - ■ AA 0	14	0.49/ 4.337	182/ 401.31
		15.7/21.1	1000/737	40	1050/773.9	1FW3204-1 ■ E ■ 2 - ■ AA 0	14	0.70/ 6.196	223/ 491.72
		23.6/31.7	1500/1105.5	65	1575/1160.8	1FW3206-1 ■ E ■ 2 - ■ AA 0	14	0.97/ 8.585	279/ 615.20
		31.4/42.1	2000/1474	84	2100/1547.7	1FW3208-1 ■ E ■ 2 - ■ AA 0	14	1.31/ 11.594	348/ 767.34
	280	39.3/52.7	2500/1842.5	108	2625/1934.6	1FW3281-1 ■ E ■ 3 - ■ AA 0	17	4.10/ 36.288	628/ 1384.74
		55.0/73.8	3500/2579.5	150	3675/2708.5	1FW3283-1 ■ E ■ 3 - ■ AA 0	17	5.10/ 45.139	731/ 1611.86
		78.5/105.3	5000/3685	207	5250/3869.3	1FW3285-1 ■ E ■ 3 - ■ AA 0	17	6.60/ 58.415	885/ 1951.43
		109.9/147.4	7000/5159	292	7350/5417	1FW3288-1 ■ E ■ 3 - ■ AA 0	17	8.60/ 76.116	1087/ 2396.84

Encoder systems for motors without DRIVE-CLiQ interface:	Incremental encoder sin/cos 1 V _{pp}	belt-mounting	A	7
	Absolute encoder multturn EnDat 2048 p./r.	coaxial mounting	E	6
	Absolute encoder multturn EnDat 2048 p./r.	belt-mounting	E	7
	Multi-pole resolver	belt-mounting	S	7
	Absolute encoder Singleturn EnDat 2048 p./r.	coaxial mounting	N	6
Encoder systems for motors with DRIVE-CLiQ interface:	Incremental encoder sin/cos 1 V _{pp}	belt-mounting	D	7
	Absolute encoder multturn EnDat 2048 p./r.	coaxial mounting	F	6
	Absolute encoder multturn EnDat 2048 p./r.	belt-mounting	F	7
	Multi-pole resolver	belt-mounting	U	7
	Absolute encoder singleturn EnDat 2048 p./r.	coaxial mounting	P	6
Type:	IM B14 (for shaft height 150/200)			2
	IM B35 (for shaft height 280)			3
Terminal box top:	Cable outlet transverse right			5
	Cable outlet transverse left			6
	Cable outlet NDE			7
	Cable outlet DE			8

Other rated speeds on request.

Selection and ordering data

Motor type (continued)	Static current I_0 at $\Delta T=100\text{ K}$ A	SINAMICS Motor Module		Power cable with complete shield		
		Rated output current I_{rated} A	Order No. For complete Order No., see "SINAMICS S120".	Motor connection via terminal box		
				Terminal box type cable entry	Cable cross section Motor ¹⁾ Max. possible cross section mm ²	Order No. Power cable By the meter

Line voltage 400 V 3 AC Active Line Module ²⁾

1FW3201-1 . E . 2-....	13	18	6SL3 1 2 - 1 T E 2 1 -8AA.	gk 230 2 x M32 x 1.5	4 x 1.5 2 x 4 x 16	6FX 008-1BB11-.... 6FX 008-1BB61-....
1FW3202-1 . E . 2-....	22	30	6SL3 1 2 - 1 T E 2 3 -0AA.	gk 230 2 x M32 x 1.5	4 x 2.5 2 x 4 x 16	6FX 008-1BB21-.... 6FX 008-1BB61-....
1FW3203-1 . E . 2-....	32	30	6SL3 1 2 - 1 T E 2 3 -0AA.	gk 230 2 x M32 x 1.5	4 x 6 2 x 4 x 16	6FX 008-1BB41-.... 6FX 5 008-1BB61-....
1FW3204-1 . E . 2-....	42	45	6SL3 1 2 - 1 T E 2 4 -5AA.	gk 230 1 x M32 x 1.5	4 x 10 2 x 4 x 16	6FX 008-1BB51-.... 6FX 008-1BB61-....
1FW3206-1 . E . 2-....	68	85	6SL3 1 2 - 1 T E 2 8 -5AA.	gk 420 2 x M40 x 1.5	4 x 16 2 x 4 x 35	6FX 008-1BB61-.... 6FX 008-1BB35-....
1FW3208-1 . E . 2-....	88	85	6SL3 1 2 - 1 T E 2 8 -5AA.	gk 420 2 x M40 x 1.5	4 x 25 2 x 4 x 35	6FX 008-1BB25-.... 6FX 008-1BB35-....
1FW3281-1 . E . 2-....	113	132	6SL3 1 2 - 1 T E 3 1 -3AA.	1XB7 700 3 x M75 x 1.5	4 x 50 3 x 4 x 120	6FX 008-1BB50-.... 6FX 008-1BB12-....
1FW3283-1 . E . 2-....	158	200	6SL3 1 2 - 1 T E 3 2 -0AA.	1XB7 700 3 x M75 x 1.5	4 x 70 3 x 4 x 120	6FX 008-1BB70-.... 6FX 008-1BB12-....
1FW3285-1 . E . 2-....	217	210	6SL3 3 2 0 - 1 T E 3 2 -1AA0	1XB7 700 3 x M75 x 1.5	4 x 120 3 x 4 x 120	6FX 008-1BB12-.... 6FX 008-1BB12-....
1FW3288-1 . E . 2-....	306	310	6SL3 3 2 0 - 1 T E 3 3 -1AA0	1XB7 700 3 x M75 x 1.5	2 x 4 x 95 3 x 4 x 120	6FX 008-1BB05-.... 6FX 008-1BB12-....

Type:	
Booksize	1
Chassis	3

Cooling:	
Internal air cooling	0
External air cooling	1

Motor Module:	
Single Motor Module	1
Double Motor Module	2

Power cable model:	
MOTION-CONNECT 800	5
MOTION-CONNECT 500	8

For length code for power and signal cables, see "MOTION-CONNECT cables and connections"

¹⁾ The current carrying capacity of the power cables corresponds to IEC 60204-1 for **type of routing C** under continuous operating conditions with an ambient air temperature of +40 °C (+104 °F), designed for I_{rated} (100 K), PVC/PUR-insulated cable. The second line specifies the maximum possible cable cross sections if other ambient conditions or routing types apply. Alternative ambient conditions can be configured with the SIZER tool.

²⁾ The rated data for Smart Line/Basic Line/Power Module can be found in the data sheets in Planning Manual 1FW3 SINAMICS.

AC motors

Synchronous motors

1FW3 torque motors Water cooling

Selection and ordering data

Rated speed	Shaft height	Rated power	Rated torque	Rated current	Static torque	1FW3 torque motors Water cooling	Number of pole pairs	Rotor moment of inertia	Weight, approx.
n_{rated}	SH	P_{rated} at $\Delta T=100$ K	M_{rated} at $\Delta T=100$ K	I_{rated} at $\Delta T=100$ K	M_0 at $\Delta T=100$ K	Order No.		J	m
rpm		kW/HP	Nm/lb _f -ft	A	Nm/lb _f -ft			kgm ² / lb _f -in ⁻²	kg/lb
Line voltage 400 V 3 AC Active Line Module 2)									
250	280	62.8/84.2	2400/1768.8	153	2652/1934.6	1FW3281-1 ■ G ■ 3 - ■ AA 0	17	4.10/ 36.288	628/ 1384.74
		89/119.4	3400/2505.8	222	3675/2708.5	1FW3283-1 ■ G ■ 3 - ■ AA 0	17	5.10/ 45.139	731/ 1611.86
		125.6/168.4	4800/3537.6	306	5250/3869.3	1FW3285-1 ■ G ■ 3 - ■ AA 0	17	6.6/ 58.415	885/ 1951.43
		175.3/235.1	6700/4937.9	435	7350/5417	1FW3288-1 ■ G ■ 3 - ■ AA 0	17	10.70/ 76.116	1087/ 2396.84
300	150	3.1/4.2	100/73.7	7.2	105/77.4	1FW3150-1 ■ H ■ 2 - ■ AA 0	7	0.12/ 1.062	87/ 191.84
		6.3/8.5	200/147.4	14	210/154.8	1FW3152-1 ■ H ■ 2 - ■ AA 0	7	0.16/ 1.416	108/ 238.14
		9.4/12.6	300/221.1	20.5	315/232.2	1FW3154-1 ■ H ■ 2 - ■ AA 0	7	0.20/ 1.770	129/ 284.45
		12.6/16.9	400/294.8	28	420/309.5	1FW3155-1 ■ H ■ 2 - ■ AA 0	7	0.24/ 2.124	150/ 330.75
		15.7/21.1	500/368.5	34	525/386.9	1FW3156-1 ■ H ■ 2 - ■ AA 0	7	0.28/ 2.478	171/ 377.06
	200	9.4/12.6	300/221.1	23	315/232.2	1FW3201-1 ■ H ■ 2 - ■ AA 0	14	0.22/ 1.947	127/ 280.04
		15.7/21.1	500/368.5	37	525/386.9	1FW3202-1 ■ H ■ 2 - ■ AA 0	14	0.36/ 3.186	156/ 343.98
		23.6/31.7	750/552.8	59	790/582.2	1FW3203-1 ■ H ■ 2 - ■ AA 0	14	0.49/ 4.337	182/ 401.31
		31.4/42.1	1000/737	74	1050/773.9	1FW3204-1 ■ H ■ 2 - ■ AA 0	14	0.70/ 6.196	223/ 491.72
		47.1/63.2	1500/1105.5	118	1575/1160.8	1FW3206-1 ■ H ■ 2 - ■ AA 0	14	0.97/ 8.585	279/ 615.20
		62.8/84.2	2000/1474	153	2100/1547.7	1FW3208-1 ■ H ■ 2 - ■ AA 0	14	1.31/ 11.594	348/ 767.34
		Encoder systems for motors without DRIVE-CLiQ interface:		Incremental encoder sin/cos 1 V_{pp} Absolute encoder multturn EnDat 2048 r./p. Absolute encoder multturn EnDat 2048 r./p. Multi-pole resolver Absolute encoder singleturn EnDat 2048 r./p.			belt-mounting coaxial mounting belt-mounting belt-mounting coaxial mounting		A 7 E 6 S 7 N 6
Encoder systems for motors with DRIVE-CLiQ interface:		Incremental encoder sin/cos 1 V_{pp} Absolute encoder multturn EnDat 2048 r./p. Absolute encoder multturn EnDat 2048 r./p. Multi-pole resolver Absolute encoder singleturn EnDat 2048 r./p.			belt-mounting coaxial mounting belt-mounting belt-mounting coaxial mounting		D 7 F 6 F 7 U 7 P 6		
Type:		IM B14 (for shaft height 150/200) IM B35 (for shaft height 280)					2 3		
Terminal box top:		Cable outlet transverse right Cable outlet transverse left Cable outlet NDE Cable outlet DE					5 6 7 8		

Other rated speeds on request.

Selection and ordering data

Motor type (continued)	Static current I_0 at $\Delta T=100\text{ K}$ A	SINAMICS Motor Module Rated output current		Power cable with complete shield Motor connection via terminal box		
		I_{rated} A	Order No. For complete Order No., see "SINAMICS S120".	Terminal box type cable entry	Cable cross section Motor ¹⁾ Max. possible cross section mm ²	Order No. Power cable By the meter

Line voltage 400 V 3 AC Active Line Module ²⁾

1FW3281-1.G.3-....	167	200	6SL3 1 2 - 1 T E 3 2 -0AA.	1XB7 700 3 x M75 x 1.5	4 x 95 3 x 4 x 120	6FX 008-1BB05-.... 6FX 008-1BB12-....
1FW3283-1.G.3-....	239	260	6SL3 3 2 0 - 1 T E 3 2 -6AA0	1XB7 700 3 x M75 x 1.5	4 x 120 3 x 4 x 120	6FX 008-1BB12-.... 6FX 008-1BB12-....
1FW3285-1.G.3-....	332	310	6SL3 3 2 0 - 1 T E 3 3 -1AA0	1XB7 700 3 x M75 x 1.5	2 x 4 x 95 3 x 4 x 120	6FX 008-1BB05-.... 6FX 008-1BB12-....
1FW3288-1.G.3-....	474	490	6SL3 3 2 0 - 1 T E 3 5 -0AA0	1XB7 700 3 x M75 x 1.5	3 x 4 x 120 3 x 4 x 120	6FX 008-1BB12-.... 6FX 008-1BB12-....
1FW3150-1.H.2-....	7.3	9	6SL3 1 2 - - T E 2 1 -0AA.	gk 230 2 x M32 x 1.5	4 x 1.5 2 x 4 x 16	6FX 008-1BB11-.... 6FX 008-1BB61-....
1FW3152-1.H.2-....	15	18	6SL3 1 2 - - T E 2 1 -8AA.	gk 230 2 x M32 x 1.5	4 x 1.5 2 x 4 x 16	6FX 008-1BB11-.... 6FX 008-1BB61-....
1FW3154-1.H.2-....	21.5	30	6SL3 1 2 - 1 T E 2 3 -0AA.	gk 230 2 x M32 x 1.5	4 x 4 2 x 4 x 16	6FX 008-1BB31-.... 6FX 008-1BB61-....
1FW3155-1.H.2-....	29	30	6SL3 1 2 - 1 T E 2 3 -0AA.	gk 230 2 x M32 x 1.5	4 x 6 2 x 4 x 16	6FX 008-1BB41-.... 6FX 008-1BB61-....
1FW3156-1.H.2-....	35	45	6SL3 1 2 - 1 T E 2 4 -5AA.	gk 230 2 x M32 x 1.5	4 x 6 2 x 4 x 16	6FX 008-1BB41-.... 6FX 008-1BB61-....
1FW3201-1.H.2-....	24	30	6SL3 1 2 - 1 T E 2 3 -0AA.	gk 230 2 x M32 x 1.5	4 x 4 2 x 4 x 16	6FX 008-1BB31-.... 6FX 008-1BB61-....
1FW3202-1.H.2-....	39	45	6SL3 1 2 - 1 T E 2 4 -5AA.	gk 230 2 x M32 x 1.5	4 x 10 2 x 4 x 16	6FX 008-1BB51-.... 6FX 008-1BB61-....
1FW3203-1.H.2-....	62	60	6SL3 1 2 - 1 T E 2 6 -0AA.	gk 420 2 x M40 x 1.5	4 x 16 2 x 4 x 35	6FX 008-1BB61-.... 6FX 008-1BB35-....
1FW3204-1.H.2-....	77	85	6SL3 1 2 - 1 T E 2 8 -5AA.	gk 420 2 x M40 x 1.5	4 x 25 2 x 4 x 35	6FX 008-1BB25-.... 6FX 008-1BB35-....
1FW3206-1.H.2-....	121	132	6SL3 1 2 - 1 T E 3 1 -3AA.	gk 630 2 x M50 x 1.5	4 x 50 2 x 4 x 50	6FX 008-1BB50-.... 6FX 008-1BB50-....
1FW3208-1.E.2-....	160	200	6SL3 1 2 - 1 T E 3 2 -0AA.	gk 630 2 x M50 x 1.5	2 x 4 x 35 2 x 4 x 50	6FX 008-1BB35-.... 6FX 008-1BB50-....

Type:	
Booksize	1
Chassis	3
Cooling:	
Internal air cooling	0
External air cooling	1
Motor Module:	
Single Motor Module	1
Double Motor Module	2
Power cable model:	
MOTION-CONNECT 800	5
MOTION-CONNECT 500	8

For length code for power and signal cables, see "MOTION-CONNECT cables and connections"

¹⁾ The current carrying capacity of the power cables corresponds to IEC 60204-1 for **type of routing C** under continuous operating conditions with an ambient air temperature of +40 °C (+104 °F), designed for I_{rated} (100 K), PVC/PUR-insulated cable. The second line specifies the maximum possible cable cross sections if other ambient conditions or routing types apply. Alternative ambient conditions can be configured with the SIZER tool.

²⁾ The rated data for Smart Line/Basic Line/Power Module can be found in the data sheets in Planning Manual 1FW3 SINAMICS.

AC motors

Synchronous motors

1FW3 torque motors Water cooling

Selection and ordering data

Rated speed	Shaft height	Rated power	Rated torque	Rated current	Static torque	1FW3 torque motors Water cooling	Number of pole pairs	Rotor moment of inertia	Weight, approx.	
n_{rated}	SH	P_{rated} at $\Delta T=100\text{ K}$	M_{rated} at $\Delta T=100\text{ K}$	I_{rated} at $\Delta T=100\text{ K}$	M_0 at $\Delta T=100\text{ K}$	Order No.		J	m	
rpm		kW/HP	Nm/lb _f -ft	A	Nm/lb _f -ft			kgm ² / lb _f -in ² -s ²	kg/lb	
Line voltage 400 V 3 AC Active Line Module²⁾										
500	150	5.2/7.0	100/73.7	11.0	105/77.4	1FW3150-1 ■ L ■ 2 - ■ AA 0	7	0.12/ 1.062	87/ 191.84	
		10.5/14.1	200/147.4	22.0	210/154.8	1FW3152-1 ■ L ■ 2 - ■ AA 0	7	0.16/ 1.416	108/ 238.14	
		15.7/21.1	300/221.1	32.0	315/232.2	1FW3154-1 ■ L ■ 2 - ■ AA 0	7	0.20 1.770	129/ 284.45	
		20.9/28.0	400/294.8	43.0	420/309.5	1FW3155-1 ■ L ■ 2 - ■ AA 0	7	0.24 2.124	150/ 330.75	
		26.2/35.1	500/368.5	53.0	525/386.9	1FW3156-1 ■ L ■ 2 - ■ AA 0	14	0.28 2.478	171/ 377.06	
	200	15.7/21.1	300/221.1	37.0	315/232.2	1FW3201-1 ■ L ■ 2 - ■ AA 0	14	0.22 1.947	127/ 280.04	
		26.2/35.1	500/368.5	59.0	525/386.9	1FW3202-1 ■ L ■ 3 - ■ AA 0	14	0.36 3.186	156/ 343.98	
		39.3/52.7	750/552.8	92.0	790/582.2	1FW3203-1 ■ L ■ 3 - ■ AA 0	14	0.49 4.337	182/ 401.31	
		52.3/70.1	1000/737	118.0	1050/773.9	1FW3204-1 ■ L ■ 3 - ■ AA 0	14	0.70 6.196	223/ 491.72	
		73.3/98.3	1400/1031.8	169.0	1575/1160.8	1FW3206-1 ■ L ■ 3 - ■ AA 0	14	0.97 8.585	279/ 615.20	
		96.8/129.8	1850/1363.5	226.0	2100/1547.7	1FW3208-1 ■ L ■ 2 - ■ AA 0	14	1.31 11.594	348/ 767.34	
	800	150	8.4/11.3	100/73.7	17.0	105/77.4	1FW3150-1 ■ P ■ 2 - ■ AA 0	7	0.12/ 1.062	87/ 191.84
			16.7/22.4	210/154.8	32.5	210/154.8	1FW3152-1 ■ P ■ 2 - ■ AA 0	7	0.16/ 1.416	108/ 238.14
			25.1/33.7	300/221.1	47.5	315/232.2	1FW3154-1 ■ P ■ 2 - ■ AA 0	7	0.20 1.770	129/ 284.45
33.5/44.9			400/294.8	64.0	420/309.5	1FW3155-1 ■ P ■ 2 - ■ AA 0	7	0.24 2.124	150/ 330.75	
41.9/56.2			500/368.5	76.0	525/386.9	1FW3156-1 ■ P ■ 2 - ■ AA 0	7	0.28 2.478	171/ 377.06	
Encoder systems for motors without DRIVE-CLiQ interface:	Incremental encoder sin/cos 1 V _{pp}		belt-mounting		A	7				
	Absolute encoder Multiturn EnDat 2048 r./p.		coaxial mounting		E	6				
	Absolute encoder Multiturn EnDat 2048 r./p.		belt-mounting		E	7				
	Multi-pole resolver		belt-mounting		S	7				
Encoder systems for motors with DRIVE-CLiQ interface:	Absolute encoder Singleturn EnDat 2048 r./p.		coaxial mounting		N	6				
	Incremental encoder sin/cos 1 V _{pp}		belt-mounting		D	7				
	Absolute encoder Multiturn EnDat 2048 r./p.		coaxial mounting		F	6				
	Absolute encoder Multiturn EnDat 2048 r./p.		belt-mounting		F	7				
Multi-pole resolver	belt-mounting		belt-mounting		U	7				
	belt-mounting		coaxial mounting		P	6				
	coaxial mounting									
Type:	IM B14 (for shaft height 150/200)					2				
	IM B35 (for shaft height 280)					3				
Terminal box top:	Cable outlet transverse right					5				
	Cable outlet transverse left					6				
	Cable outlet NDE					7				
	Cable outlet DE					8				

Other rated speeds on request.

Selection and ordering data

Motor type (continued)	Static current I_0 at $\Delta T=100\text{ K}$ A	SINAMICS Motor Module Rated output current		Power cable with complete shield Motor connection via terminal box		
		I_{rated} A	Order No. For complete Order No., see "SINAMICS S120".	Terminal box type cable entry	Cable cross section Motor ¹⁾ Max. possible cross section mm ²	Order No. Power cable By the meter

Line voltage 400 V 3 AC Active Line Module ²⁾

1FW3150-1.L.2-....	11.5	18	6SL3 1 2 - - T E 2 1 -8AA.	gk 230 2 x M32 x 1.5	4 x 1.5 2 x 4 x 16	6FX 008-1BB11-.... 6FX 008-1BB61-....
1FW3152-1.L.2-....	22.5	30	6SL3 3 2 - - 1 T E 2 3 -0AA.	gk 230 2 x M32 x 1.5	4 x 4 2 x 4 x 16	6FX 008-1BB31-.... 6FX 008-1BB61-....
1FW3154-1.L.2-....	33	45	6SL3 3 2 - - 1 T E 2 4 -5AA.	gk 230 2 x M32 x 1.5	4 x 6 2 x 4 x 16	6FX 008-1BB41-.... 6FX 008-1BB61-....
1FW3155-1.L.2-....	45	60	6SL3 3 2 - - 1 T E 2 6 -0AA.	gk 230 2 x M32 x 1.5	4 x 10 2 x 4 x 16	6FX 008-1BB51-.... 6FX 008-1BB61-....
1FW3156-1.L.2-....	55	60	6SL3 1 2 - - 1 T E 2 6 -0AA.	gk 420 2 x M40 x 1.5	4 x 16 2 x 4 x 35	6FX 008-1BB61-.... 6FX 008-1BB35-....
1FW3201-1.L.2-....	38	45	6SL3 1 2 - - 1 T E 2 4 -5AA.	gk 230 2 x M32 x 1.5	4 x 10 2 x 4 x 16	6FX 008-1BB51-.... 6FX 008-1BB35-....
1FW3202-1.L.2-....	62	60	6SL3 1 2 - - 1 T E 2 6 -0AA.	gk 420 2 x M40 x 1.5	4 x 16 2 x 4 x 35	6FX 008-1BB61-.... 6FX 008-1BB35-....
1FW3203-1.L.2-....	100	132	6SL3 1 2 - - 1 T E 3 1 -3AA.	gk 420 2 x M40 x 1.5	4 x 35 2 x 4 x 35	6FX 008-1BB35-.... 6FX 008-1BB35-....
1FW3204-1.L.2-....	129	132	6SL3 1 2 - - 1 T E 3 1 -3AA.	gk 630 2 x M50 x 1.5	2 x 4 x 50 2 x 4 x 50	6FX 008-1BB50-.... 6FX 008-1BB50-....
1FW3206-1.L.2-....	189	200	6SL3 1 2 - - 1 T E 3 2 -0AA.	gk 630 2 x M50 x 1.5	2 x 4 x 35 2 x 4 x 50	6FX 008-1BB35-.... 6FX 008-1BB50-....
1FW3208-1.L.2-....	256	260	6SL3 3 2 0 - 1 T E 3 2 -6AA.	gk 630 2 x M50 x 1.5	2 x 4 x 50 2 x 4 x 50	6FX 008-1BB50-.... 6FX 008-1BB50-....
1FW3150-1.P.2-....	17.5	18	6SL3 1 2 - - T E 2 1 -8AA.	gk 230 2 x M32 x 1.5	4 x 2.5 2 x 4 x 16	6FX 008-1BB25-.... 6FX 008-1BB61-....
1FW3152-1.P.2-....	33.5	45	6SL3 1 2 - - 1 T E 2 4 -5AA.	gk 230 2 x M32 x 1.5	4 x 6 2 x 4 x 16	6FX 008-1BB41-.... 6FX 008-1BB61-....
1FW3154-1.P.2-....	49	60	6SL3 1 2 - - 1 T E 2 6 -0AA.	gk 230 2 x M32 x 1.5	4 x 10 2 x 4 x 16	6FX 008-1BB51-.... 6FX 008-1BB61-....
1FW3155-1.P.2-....	67	85	6SL3 1 2 - - 1 T E 2 8 -5AA.	gk 420 2 x M40 x 1.5	4 x 25 2 x 4 x 35	6FX 008-1BB25-.... 6FX 008-1BB35-....
1FW3156-1.P.2-....	80	85	6SL3 1 2 - - 1 T E 2 8 -5AA.	gk 420 2 x M40 x 1.5	4 x 25 2 x 4 x 35	6FX 008-1BB25-.... 6FX 008-1BB35-....

Type:	
Booksize	1
Chassis	3
Cooling:	
Internal air cooling	0
External air cooling	1
Motor Module:	
Single Motor Module	1
Double Motor Module	2
Power cable model:	
MOTION-CONNECT 800	5
MOTION-CONNECT 500	8

For length code for power and signal cables, see "MOTION-CONNECT cables and connections"

¹⁾ The current carrying capacity of the power cables corresponds to IEC 60204-1 for **type of routing C** under continuous operating conditions with an ambient air temperature of +40 °C (+104 °F), designed for I_{rated} (100 K), PVC/PUR-insulated cable. The second line specifies the maximum possible cable cross sections if other ambient conditions or routing types apply. Alternative ambient conditions can be configured with the SIZER tool.

²⁾ The rated data for Smart Line/Basic Line/Power Module can be found in the data sheets in Planning Manual 1FW3 SINAMICS.

AC motors

Synchronous motors

Selection guides

Built-in holding brakes

Many drives need a holding brake with an emergency stop function for industrial or safety-related reasons.

Built-in holding brakes for 1FK7 and 1FT6 motors

The permanent-magnet or spring-loaded, single-face brakes used for these motor ranges function according to the closed-circuit current principle. The magnetic field of the permanent magnet exerts a tension on the brake armature plate, i.e. in a condition of zero current, the brake is closed and the motor shaft thereby stopped. When the rated voltage of 24 V DC is applied to the brake, current flows through the coil and produces a counter-field that cancels the pull of the permanent magnet, causing the brake to release.

The spring-loaded, single-face brake operates by the force of pressure exerted by the spring instead of a permanent magnet.

In the event of an emergency stop or power failure, approximately 2000 braking operations can be performed with the maximum switched energy without causing excessive wear on the holding brake (condition: maximum external moment of inertia = moment of inertia of motor and n_{max} , type-specific).

The holding brake is not an operational brake.







In order to avoid opening switching overvoltages and any related effects on the plant environment, the brake cables must be connected externally with a varistor. The connection is made via the power connector or the terminal box.

Technical data for built-in holding brakes (brake supply voltage 24 V DC $\pm 10\%$)

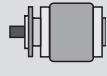
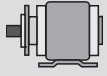
Frame size	Motor type	Brake type	Holding torque ¹⁾	Direct current	Opening time with varistor	Closing time with varistor	Moment of inertia	Maximum switched energy per brake operation from $n = 3000$ rpm
			Nm/lb _f -ft	A	ms	ms	10^{-4} kgm ² / lb _f -in-s ²	J
for 1FK7 Compact motors								
20	1FK7 01.-	HT03P	0.4/0.3	0.3	30	20	0.019/0.00002	2
28	1FK7 022	EBD 0.11 BN	1.0/0.7	0.3	30	20	0.07/0.00006	8
36	1FK7 032	EBD 0.13 BN	1.3/1	0.4	50	30	0.08/0.00007	17
48	1FK7 04.	EBD 0.3 BV	3.2/2.4	0.6	70	30	0.72/0.0006	74
63	1FK7 06.	EBD 0.8 BK	13/9.6	0.8	100	50	2.25/0.002	400
80	1FK7 080	EBD 1.5 BN	10/7.4	0.7	100	50	3.1/0.0027	400
80	1FK7 083	EBD 2 BY	22/16.2	0.9	200	60	8.6/0.0076	1400
100	1FK7 100	EBD 2 BY	22/16.2	0.9	200	60	8.6/0.0076	1400
100	1FK7 101/103/105	EBD 3.5 BV	41/30.2	1.0	300	70	13.5/0.0119	3000
for 1FK7 High Dynamic motors								
36	1FK7 03.	1EB 14-30	1.3/1	0.5	100	40	0.12/0.0001	14
48	1FK7 04.	1EB 20-40	4/2.9	0.6	150	50	0.13/0.0001	96
63	1FK7 06.	1EB 28-60	12/8.8	0.8	150	50	0.34/0.0003	230
80	1FK7 08.	1EB 35-80	22/16.2	1.2	200	60	2.0/0.0018	700
for 1FT6 motors								
28	1FT6 02.	EBD 0.11 B	1.0/0.7	0.3	20	10	0.07/0.00006	9
36	1FT6 03.	EBD 0.15 B	2/1.5	0.4	30	15	0.12/0.0001	27
48	1FT6 04.	EBD 0.4 BA	5/3.7	0.8	30	15	1.06/0.0009	125
63	1FT6 06.	EBD 1.5 B	15/11.1	0.8	130	30	3.2/0.0027	320
80	1FT6 081/082	EBD 1.2 B	15/11.1	0.8	70	35	3.2/0.0027	750
80	1FT6 084/086	EBD 3.5 BN	28/20.6	0.9	180	35	13.5/0.0119	1600
100	1FT6 10.	EBD 4 B	70/51.6	1.4	180	40	32/0.0283	2100
132	1FT6 13.	EBD 8 B	140/103.2	1.7	260	90	76/0.0673	9860

¹⁾ Minimum torque of brake in static state (stationary motor)

Type of construction/Mounting position

Type of construction/ mounting position	Designation	Type of construction/ mounting position	Designation	Type of construction/ mounting position	Designation
	IM B3		IM B5 IM B14		IM B35
	IM V5		IM V1 IM V18		IM V15
	IM V6		IM V3 IM V19		IM V36

Degree of protection

The degree of protection designation in accordance with EN 60034-5 and IEC 60034-5 consists of the letters "IP" and two digits (e.g. IP64). The second digit in the degree of protection designation represents protection against water, the first digit protection against penetration of foreign matter.

Since coolants are used for machine tools and transfer machines that contain oil, are able to creep, and may also be corrosive, protection against water alone is insufficient. The designation for the degree of protection should only be considered here as a guideline. Our sealing systems are based on many years of practical experience, exceed the IEC specifications by far, and are appropriate to the requirements of machine tools.

The table can serve as a decision aid for selecting the proper degree of protection for motors. With the IM V3/IM V19 construction types, permanent liquid on the flange is only permissible with IP67/IP68.

Liquids / Effect	General workshop environment	Water general coolant (95% water, 5% oil) Oil	Creep oil; petroleum; aggressive coolants
Dry	IP64	–	
Water-enriched environment	–	IP64	IP67
Mist		IP65	IP67
Spray	–	IP65	IP68
Jet	–	IP67	IP68
Splash, brief immersion; constant immersion	–	IP67	IP68

AC motors

Selection guides

Selection guides

Options

Options

Order code	Option description	Explanation
M03	Version for Zone 2 hazardous areas (in accordance with IEC EN 60079-15)	<p>Combustible or explosive gases or vapors occur only rarely or briefly in Zone 2 areas. The type of protection designation is Eex nA II ("non sparking").</p> <p>The special conditions for operating 1FK7 motors in Zone 2 areas, in particular the reduction in permissible operating speeds, are described in detail in Appendix 610.40063.01 to the EC Declaration of Conformity 664.20025.21.</p> <p>The special conditions for operating 1FT6 motors in Zone 2 areas, in particular the reduction in permissible operating speeds, are described in detail in Appendix 610.40061.01 to the EC Declaration of Conformity 664.20023.21.</p> <p>Only for:</p> <ul style="list-style-type: none"> – Natural cooling up to SH 100 – Water cooling SH 63 to 100
M39	Version for Zone 22 hazardous areas (in accordance with EN 50281)	<p>Combustible or explosive dust (non-conductive dust) occurs only rarely or briefly in Zone 22 areas. The type of protection designation is Ex 3D T 150 °C (302 °F).</p> <p>The special conditions for operating 1FK7 motors in Zone 22 areas are described in detail in Appendix 610.40071.01 to the EC Declaration of Conformity 664.20031.21.</p> <p>The special conditions for operating 1FT6 motors in Zone 22 areas are described in detail in Appendix 610.40070.01 to the EC Declaration of Conformity 664.20030.21.</p> <p>Only for:</p> <ul style="list-style-type: none"> – Natural cooling up to SH 100 – Water cooling SH 63 to 100
N05	Non-standard shaft extension (dimensions as for 1FT5 motors)	<p>1FK7 and 1FT6 motors are shipped with the following shaft dimensions that are compatible with 1FT5 motors:</p> <ul style="list-style-type: none"> – SH 36: 11 x 23 mm (0.43 x 0.91 in) – SH 48: 14 x 30 mm (0.55 x 1.18 in) – SH 63: 19 x 40 mm (0.75 x 1.57 in) – SH 80: 24 x 50 mm (0.94 x 1.97 in) – SH 100: 32 x 58 mm (1.26 x 2.28 in) <p>Comment:</p> <p>1FK7 and 1FT6 motors of SH 63 with option N05 do <u>not</u> have a compatible flange with 1FT5 motors of SH 63.</p> <p>For natural cooling, forced ventilation and water cooling</p>
N40	Variant for food processing industry	<p>1FT6 motors in shaft heights 63 to 100 (naturally or water cooled) are designed with the following features:</p> <ul style="list-style-type: none"> – Stainless steel shaft and fitted key – Bearing sealed with special grease and shaft seal with stainless steel annular spring – Degree of protection IP68 – Must be connected by plug (zinc die-cast), terminal box connection is not possible – Paint finish: Primer plus light top coat (white aluminum RAL 9006)
Q90	Food-grade gear oil	Only for 1FK7 Compact with helical and bevel gears

Overview

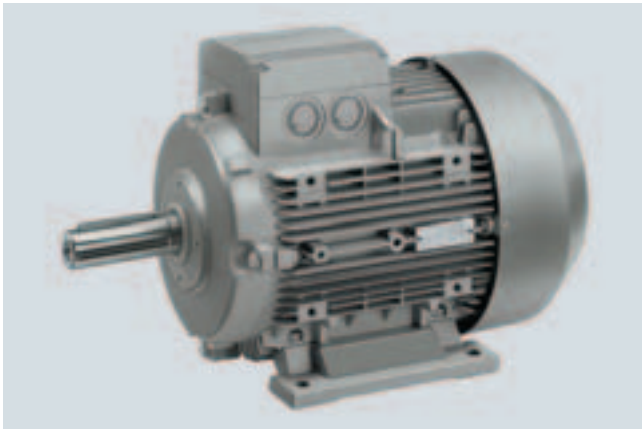

1LA and 1LG motors



1LA8 motors

Asynchronous motors

1PH7, 1PL6 and 1PH4 motors

The full capability of the SINAMICS S120 Vector Control can be utilized when the drive system is combined with motors of this type. The Control Unit evaluates the electronic rating plate as well as the motor-integrated encoder signals via the DRIVE-CLiQ interface. This means that motor and encoder data do not need to be parameterized when the system is commissioned or serviced. 1PH7, 1PL6 and 1PH4 motors are designed for converter operation and are characterized by their high power density and wide speed range. These motors are available in a variety of construction types and models for a wide range of drive applications.

1LA, 1LG, 1MA and 1MJ motors

These motors are designed for direct connection to a three-phase supply system, and they can also operate with the SINAMICS drive system. For technical data and engineering information, please refer to Catalog D 81.1.

1PQ motors

As these motors use forced ventilation, no derating or only relatively minor derating (depending on their speed range) is required for constant-torque applications and wide speed ranges.

Synchronous motors

1FU8 motors

1FU8 permanent-magnet SIEMOSYN synchronous motors can be operated in the "V/f control" mode. These motors are used as stand-alone or sectional drives for applications demanding high speeds, excellent speed accuracy and absolute synchronous operation. They are used primarily in the man-made fiber industry. For detailed motor selection, refer to Catalog DA 48.

Non-Siemens motors

Standard asynchronous motors supplied by other manufacturers can operate on the SINAMICS S120 drive system provided they are designed for converter operation with high-speed IGBT power unit.

AC motors

Asynchronous motors

1PH7 motors

Overview



1PH7 AC motors, shaft heights 100 to 160



1PH7 AC motors, shaft heights 180 and 225



1PH7 AC motors, shaft height 280

The 1PH7 AC motors are compact, force-ventilated squirrel-cage asynchronous motors with degree of protection IP55. The motors are ventilated using a built-on separately-driven fan unit.

The motor can be ordered either with the air flow from the motor drive end (DE) to the motor non-drive end (NDE) - or vice versa.

These motors have been designed specifically for use in conjunction with converters. Depending on the control requirements, the appropriate encoder systems are available for the motors. These encoders are used to sense the motor speed and indirect position.

Benefits

- High power density with small motor dimensions
- High degree of protection
- Wide speed control ranges
- Speed down to zero without reducing the torque
- Robustness
- Essentially maintenance-free
- High cantilever force loading
- High rotational accuracy, even at the lowest speeds
- Integrated encoder system to sense the motor speed, connected using a connector or DRIVE-CLiQ
- Terminal box to connect up power cables
- Motor temperature monitoring with KTY 84
- Variable cooling versions
- Basic external cooling using a pipe connection
- Optional bearing designs with re-lubrication device and insulated bearings (NDE)

Applications

Installation in dry inside areas (no corrosive atmosphere).

Crane systems:

- Hoisting and closing gears for cranes
- Hoisting and traversing gears for high-bay racking vehicles

Printing industry:

- Single and main drives for printing machines

Rubber, plastic, wire, and glass manufacturing:

- Drives for extruders, calendars, rubber injection machines, foil machines, fleece plants
- Wire-drawing machines, cable stranding machines, etc.

General applications such as coiler and winder drives.

Technical data

Insulation of the stator winding in accordance with EN 60034-1 (IEC 60034-1)	Thermal Class F for a coolant temperature of up to +40 °C (+104 °F)
Fan supply voltage (see selection guides for technical data)	400 V 3 AC, 50Hz/60 Hz 480 V 3 AC, 60 Hz
Type in accordance with EN 60034-7 (IEC 60034-7)	IM B3
Degree of protection in accordance with EN 60034-5 (IEC 60034-5)	IP55 (fan IP54)
Cooling in accordance with EN 60034-6 (IEC 60034-6)	Forced ventilation SH 100 to 225: Fan mounted axially at NDE SH 280: Fan mounted radially at NDE
Temperature monitoring	KTY84 temperature sensor in the stator winding for SH 280: Additional KTY 84 as reserve
Paint finish	SH 100 to 160: without finish, Standard finish anthracite RAL 7016 SH 180 to 280: Primed, standard finish anthracite RAL 7016
Shaft extension on the drive end in accordance with DIN 748-3 (IEC 60072-1)	with fitted key, half-key balancing
Shaft and flange accuracy in accordance with DIN 42955 (IEC 60072-1)	SH 100 to 160: Tolerance R (reduced) SH 180 to 280: Tolerance N (normal)
Vibration severity grade in accordance with EN 60034-14 (IEC 60034-14)	SH 100 to 225: Grade R (reduced) SH 280: Grade N (normal)
Sound pressure level in accordance with EN ISO 1680 tolerance +3 dB	Sound pressure level as a function of air-flow direction see selection guides
Bearing versions and maximum speeds	see selection guides
Encoder system, built-in for motors with/without DRIVE-CLiQ interface	<ul style="list-style-type: none"> Incremental encoder HTL 1024 S/R Incremental encoder sin/cos 1 V_{pp} 2048 S/R Absolute encoder EnDat 2048 S/R 2-pole resolver
Connection	Connector for signals (mating connector not supplied) Terminal box for power SH 160 to 225: Terminal box at top SH 280: Terminal box NDE right
Options	Refer to options and Selection and ordering data

Characteristics

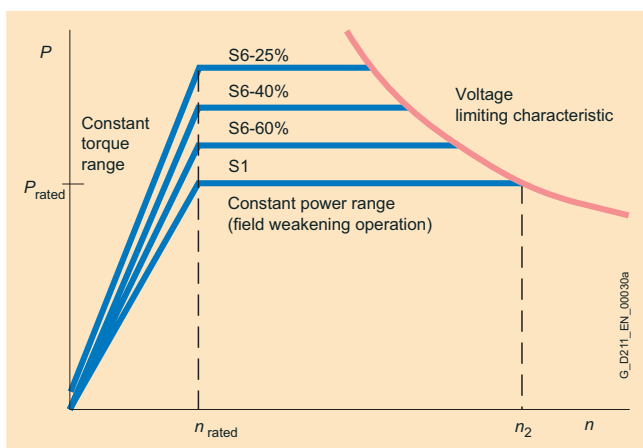

Power/speed characteristic

Options

Order Option description code	For use with 1PH7 asynchronous motors with shaft height		
	SH 100 to 160	SH 180 SH 225	SH 280
Standard finish in another color, RAL ...	● ¹⁾	■ ²⁾	■ ²⁾
Special finish in another color, RAL ...	●	■ ³⁾	■ ³⁾
C30 Winding version 690 V	-	-	■
G14 Fan unit with air filter	-	●	■
G80 POG10 pulse encoder, mounting prepared	-	-	■
K08 Encoder connector mounted opposite	-	-	■
K16 Second standard shaft extension (only possible without encoder)	-	-	■
K31 2nd rating plate supplied separately in terminal box	✓	■	■
K40 Re-lubrication devices, DE and NDE	-	■ ⁴⁾	✓
K45 230 V anti-condensation heating	-	-	■
K55 Cable entry plate, terminal box, customer-specific (plain text is required)	-	■	■
K83 Terminal box rotated through +90 degrees	-	-	■
K84 Terminal box rotated through -90 degrees	-	-	■
K85 Terminal box rotated through 180 degrees	-	-	■
L27 NDE bearing, insulated version	-	■	✓
M03 ⁵⁾ Version for Zone 2 hazardous areas (in accordance with IEC EN 60079-15)	■	-	-
M39 ⁵⁾ Version for Zone 22 hazardous areas (in accordance with EN 50281)	■	■	■
M83 Additional thread for a setting screw on motor feet	-	-	■
Y55 Non-standard shaft extension DE	●	●	●
Y80 Different rating plate data (plain text is required)	●	●	●
Y82 Extra rating plate with customer data	●	●	●

■ Option available

● On request

- Not available

✓ Standard

1) Order using a short code (without plain text), e.g.:

- X01:** RAL 9005 (jet black)
- X02:** RAL 9001 (cream)
- X03:** RAL 6011 (reseda green)
- X04:** RAL 7032 (pebble gray)
- X05:** RAL 5015 (sky blue)
- X06:** RAL 1015 (light ivory)

2) Order using a short code **R1Y** (RAL color must be specified in plain text).

3) Order using a short code **R2Y** (RAL color must be specified in plain text).

4) Not compatible with bearing for increased maximum speed.

5) The general conditions and information in the declarations of conformity must be taken into account. Declarations of conformity are available on request from your local Siemens sales office.

AC motors

Asynchronous motors

1PH7 motors

Selection and ordering data

Rated speed n_{rated} rpm	Shaft height SH	Rated power P_{rated} kW/HP	Rated torque M_{rated} Nm/lb _f -ft	Rated current I_{rated} A	Rated voltage V_{rated} V	Speed during field weakening ¹⁾ n_2 rpm	Max. permissible continuous speed ²⁾ n_{S1} rpm	Max. speed ³⁾ n_{max} rpm	1PH7 asynchronous motor Order No.
400 V 3 AC line voltage, Servo Control									
400	160	9.5/12.7	227/167.3	30	274	1940	3700 ⁹⁾	6500 ⁹⁾	1PH7163-■ ■ B ■ ■ - ■ ...
		13/17.4	310/228.5	37	294	1540	3700 ⁹⁾	6500 ⁹⁾	1PH7167-■ ■ B ■ ■ - ■ ...
1000	100	3.7/5.0	35/25.8	10	343	2250	5500 ⁹⁾	9000 ⁹⁾	1PH7103-■ ■ D ■ ■ - ■ ...
		6.3/8.5	60/44.2	17.5	319	3560	5500 ⁹⁾	9000 ⁹⁾	1PH7107-■ ■ D ■ ■ - ■ ...
	132	12/16.1	115/84.8	30	336	2500	4500	8000 ⁹⁾	1PH7133-■ ■ D ■ ■ - ■ ...
		17/22.8	162/119.4	43	322	3390	4500	8000 ⁹⁾	1PH7137-■ ■ D ■ ■ - ■ ...
1500	160	22/29.5	210/154.8	55	315	2750	3700	6500 ⁹⁾	1PH7163-■ ■ D ■ ■ - ■ ...
		28/37.6	267/196.8	71	312	4090	3700	6500 ⁹⁾	1PH7167-■ ■ D ■ ■ - ■ ...
	100	3.7/5.0	24/17.7	10	350	5360	5500	9000 ⁹⁾	1PH7101-■ ■ F ■ ■ - ■ ...
		5.5/7.4	35/25.8	13	350	3000	5500	9000 ⁹⁾	1PH7103-■ ■ F ■ ■ - ■ ...
		7.0/9.4	45/33.2	17.5	346	5110	5500	9000 ⁹⁾	1PH7105-■ ■ F ■ ■ - ■ ...
		9.0/12.1	57/42	23.5	336	3500	5500	9000 ⁹⁾	1PH7107-■ ■ F ■ ■ - ■ ...
	132	11/14.8	70/51.6	24	350	4310	4500	8000 ⁹⁾	1PH7131-■ ■ F ■ ■ - ■ ...
		15/20.1	96/70.8	34	346	4400	4500	8000 ⁹⁾	1PH7133-■ ■ F ■ ■ - ■ ...
		18.5/24.8	118/87	42	350	4920	4500	8000 ⁹⁾	1PH7135-■ ■ F ■ ■ - ■ ...
		22/29.5	140/103.2	57	308	3750	4500	8000 ⁹⁾	1PH7137-■ ■ F ■ ■ - ■ ...
	160	30/40.2	191/140.8	72	319	4000	3700	6500	1PH7163-■ ■ F ■ ■ - ■ ...
		37/49.6	236/173.9	82	350	2750	3700	6500	1PH7167-■ ■ F ■ ■ - ■ ...
2000	100	7/9.4	33/24.3	17.5	343	4630	5500	9000	1PH7103-■ ■ G ■ ■ - ■ ...
		10.5/14.1	50/36.9	26	350	4000	5500	9000	1PH7107-■ ■ G ■ ■ - ■ ...
	132	20/26.8	96/70.8	45	350	4000	4500	8000	1PH7133-■ ■ G ■ ■ - ■ ...
		28/37.6	134/98.8	60	350	3750	4500	8000	1PH7137-■ ■ G ■ ■ - ■ ...
	160	36/48.3	172/126.8	85	333	3000	3700	6500	1PH7163-■ ■ G ■ ■ - ■ ...
		41/55.0	196/144.5	89	350	2750	3700	6500	1PH7167-■ ■ G ■ ■ - ■ ...
Fan:		External fan unit, heavy-gauge threaded cable entry in terminal box Without external fan unit, for pipe connection, heavy-gauge threaded cable entry in terminal box External fan unit, metric cable entry in terminal box Without external fan unit, for pipe connection, metric cable entry in terminal box							2 6 7 8
Encoder systems for motors without DRIVE-CLiQ interface:		Without encoder Absolute encoder EnDat 2048 pulses/revolution Incremental encoder HTL 1024 pulses/revolution Incremental encoder HTL 2048 pulses/revolution Incremental encoder sin/cos 1 V _{pp} with C and D tracks Incremental encoder sin/cos 1 V _{pp} without C and D tracks 2-pole resolver							A E H J M N R
Encoder systems for motors with DRIVE-CLiQ interface:		Absolute encoder EnDat 2048 pulses/revolution Incremental encoder sin/cos 1 V _{pp} with C and D tracks Incremental encoder sin/cos 1 V _{pp} without C and D tracks 2-pole resolver							F D Q P
Terminal box/cable entry (view onto DE):		Top/from right Top/from NDE Top/from left							0 2 3
Type:		IM B3 (IM V5, IM V6) IM B5 (IM V1, IM V3) available only for shaft heights 100 and 132 IM B35 (IM V15, IM V36)							0 2 3
Holding brake with emergency stop function⁴⁾:		Without brake							0
		Brake supply voltage 230 V 1 AC, 50/60 Hz	With brake With brake (includes microswitch) With brake (includes manual release) With brake (includes manual release and microswitch)						1 2 3 4
		Brake supply voltage 24 V DC	With brake With brake (includes microswitch) With brake (includes manual release) With brake (includes manual release and microswitch)						5 6 7 8

Selection and ordering data

Power factor $\cos \varphi$	Magnetizing current I_{μ} A	Efficiency η_{rated}	Rated frequency f_{rated} Hz	Moment of inertia of J kgm ² / lb _r -in-s ²	Weight, approx. kg/lb	1PH7 asynchronous motor		SINAMICS S120 Motor Module	
						Order No.	I_{rated} A	Rated output current	Order No.
400 V 3 AC line voltage, Servo Control									
0.88	11.5	0.809	14.3	0.185/1.637	175/385.9	1PH7163-.. B ■■■■	30	6SL3120- 1 TE23-0AA 1	
0.88	14.0	0.814	14.3	0.228/2.018	210/463	1PH7167-.. B ■■■■	45	6SL3120- 1 TE24-5AA 1	
0.82	4.8	0.794	35.6	0.017/0.15	40/88.2	1PH7103-.. D ■■■■	9 ⁸⁾	6SL3120- ■ TE21-0AA ■	
0.81	9	0.822	35.3	0.029/0.257	65/143.33	1PH7107-.. D ■■■■	18	6SL3120- ■ TE21-8AA ■	
0.86	13	0.865	34.8	0.076/0.673	90/198.5	1PH7133-.. D ■■■■	30	6SL3120- 1 TE23-0AA 1	
0.86	19	0.878	34.6	0.109/0.965	150/330.8	1PH7137-.. D ■■■■	45	6SL3120- 1 TE24-5AA 1	
0.85	24	0.899	34.2	0.185/1.637	175/385.9	1PH7163-.. D ■■■■	60	6SL3120- 1 TE26-0AA 1	
0.84	33	0.903	34.2	0.228/2.018	210/463	1PH7167-.. D ■■■■	85	6SL3120- 1 TE28-5AA 1	
0.74	5.9	0.847	51.6	0.017/0.15	40/88.2	1PH7101-.. F ■■■■	9 ⁸⁾	6SL3120- ■ TE21-0AA ■	
0.84	5.4	0.832	52.7	0.017/0.15	40/88.2	1PH7103-.. F ■■■■	18	6SL3120- ■ TE21-8AA ■	
0.78	9.4	0.866	51.7	0.029/0.257	65/143.33	1PH7105-.. F ■■■■	18	6SL3120- ■ TE21-8AA ■	
0.80	11.0	0.859	52.0	0.029/0.257	65/143.33	1PH7107-.. F ■■■■	30	6SL3120- 1 TE23-0AA 1	
0.88	8.4	0.896	51.3	0.076/0.673	90/198.5	1PH7131-.. F ■■■■	30	6SL3120- 1 TE23-0AA 1	
0.85	14	0.895	51.3	0.076/0.673	90/198.5	1PH7133-.. F ■■■■	45	6SL3120- 1 TE24-5AA 1	
0.85	17	0.902	51.1	0.109/0.965	150/330.8	1PH7135-.. F ■■■■	45	6SL3120- 1 TE24-5AA 1	
0.85	23	0.900	51.2	0.109/0.965	150/330.8	1PH7137-.. F ■■■■	60	6SL3120- 1 TE26-0AA 1	
0.85	30	0.912	50.9	0.185/1.637	175/385.9	1PH7163-.. F ■■■■	85	6SL3120- 1 TE28-5AA 1	
0.86	32	0.916	50.8	0.228/2.018	210/463	1PH7167-.. F ■■■■	85	6SL3120- 1 TE28-5AA 1	
0.80	8.3	0.857	68.9	0.017/0.15	40/88.2	1PH7103-.. G ■■■■	18	6SL3120- ■ TE21-8AA ■	
0.80	12	0.869	68.6	0.029/0.257	65/143.33	1PH7107-.. G ■■■■	30	6SL3120- 1 TE23-0AA 1	
0.86	18	0.898	68.0	0.076/0.673	90/198.5	1PH7133-.. G ■■■■	45	6SL3120- 1 TE24-5AA 1	
0.88	21	0.903	68.0	0.109/0.965	150/330.8	1PH7137-.. G ■■■■	60	6SL3120- 1 TE26-0AA 1	
0.84	37	0.906	67.5	0.185/1.637	175/385.9	1PH7163-.. G ■■■■	85	6SL3120- 1 TE28-5AA 1	
0.84	40	0.907	67.4	0.228/2.018	210/463	1PH7167-.. G ■■■■	85 ⁸⁾	6SL3120- 1 TE28-5AA 1	
Output type:		Vibration severity grade:		Shaft and flange accuracy:					
Coupling/belt		R		R		B C D K L			
Coupling/belt		S		R					
Coupling/belt		SR		R					
Coupling/belt		N		N (with brake mounting)					
Increased max. speed ⁵⁾		SR		R					
Shaft extension (DE):		Balancing:		Direction of air flow (fan):					
Fitted key		Half-key		DE → NDE		A B C D J K			
Fitted key		Half-key		NDE → DE ⁷⁾					
Fitted key		Full-key		DE → NDE					
Fitted key		Full-key		NDE → DE ⁷⁾					
Plain shaft		-		DE → NDE					
Plain shaft		-		NDE → DE ⁷⁾					
Seal:		Paint finish:							
-		None				0 2 3 5 6 8			
Flange + shaft sealing ring ⁶⁾		None							
-		Anthracite (RAL 7016), standard paint finish							
Flange + shaft sealing ring ⁶⁾		Anthracite (RAL 7016), standard paint finish							
-		Anthracite (RAL 7016), special paint finish				-Z			
Flange + shaft sealing ring ⁶⁾		Anthracite (RAL 7016), special paint finish							
Special versions:		Specify supplementary order code and plain text if applicable (see Options).							
Motor Module:		Single Motor Module						1	
		Double Motor Module						2	
								0	

- n_2 : Max. permissible thermal speed at constant output or speed, which is at the voltage limit when $P = P_{\text{rated}}$.
- n_{S1} : Max. permissible speed that is continuously permitted without speed duty cycles.
- n_{max} : Maximum speed which must not be exceeded.
- Model with brake possible if: 12. Position "2" or "3", 14th position "K", 15th position "A", "B", "J" or "K", 16th position "0", "3" or "6".
- Max. possible speed (see also selection guides): SH 100: 12000 rpm, SH 132: 10000 rpm, SH 160: 8000 rpm, with keyless shaft only (15th position "J" or "K" and 16th position "0", "3" or "6").

- Only appropriate if oil spray/mist occasionally gets onto the sealing ring. A sealing ring is not possible for type IM B3 (IM V5, IM V6), or version with increased maximum speed.
- Preferred air-flow direction in polluted environment.
- The rated output current of the Motor Module is lower than the motor rated current.
- Speed is limited to lower values in some cases. The following restriction applies: Max. output frequency < 5 × motor rated frequency.

AC motors

Asynchronous motors

1PH7 motors

Selection and ordering data

Rated speed n_{rated} rpm	Shaft height SH	Rated power P_{rated} kW/HP	Rated torque M_{rated} Nm/lb _r -ft	Rated current I_{rated} A	Rated voltage V_{rated} V	Speed during field weakening n_2 rpm	Max. permissible continuous speed ²⁾ n_{S1} rpm	Max. speed ³⁾ n_{max} rpm	1PH7 asynchronous motor Order No.	
400 V 3 AC line voltage, Servo Control										
400	180	16.3/21.9	390/287.4	51	271	2100 ¹⁰⁾	3500 ⁴⁾¹⁰⁾	5000 ¹⁰⁾	1PH7184-■ ■ B ■ ■ - ■ ...	
		21.2/28.4	505/372.2	67	268	2400 ¹⁰⁾	3500 ⁴⁾¹⁰⁾	5000 ¹⁰⁾	1PH7186-■ ■ B ■ ■ - ■ ...	
	225	30.4/40.8	725/534.3	88	268	1900	3100 ⁴⁾¹⁰⁾	4500 ¹⁰⁾	1PH7224-■ ■ B ■ ■ - ■ ...	
		39.2/52.6	935/689.1	114	264	2200 ¹⁰⁾	3100 ⁴⁾¹⁰⁾	4500 ¹⁰⁾	1PH7226-■ ■ B ■ ■ - ■ ...	
1000	180	48/64.4	1145/843.9	136	272	2200 ¹⁰⁾	3100 ⁴⁾¹⁰⁾	4500 ⁴⁾¹⁰⁾	1PH7228-■ ■ B ■ ■ - ■ ...	
		39/52.3	372/274.2	90	335	3300	3500 ⁴⁾	5000	1PH7184-■ ■ D ■ ■ - ■ ...	
	225	51/68.4	485/357.4	116	340	3700	3500 ⁴⁾	5000	1PH7186-■ ■ D ■ ■ - ■ ...	
		71/95.2	678/499.7	161	335	2900	3100 ⁴⁾	4500	1PH7224-■ ■ D ■ ■ - ■ ...	
92/123.4		880/649.1	198	340	2900	3100 ⁴⁾	4500	1PH7226-■ ■ D ■ ■ - ■ ...		
1500	180	113/151.5	1080/796	240	340	2900	3100 ⁴⁾	4500 ⁴⁾	1PH7228-■ ■ D ■ ■ - ■ ...	
		51/68.4	325/239.5	120	335	5000	3500 ⁴⁾	5000	1PH7184-■ ■ F ■ ■ - ■ ...	
	225	74/99.2	471/347.1	170	330	5000	3500 ⁴⁾	5000	1PH7186-■ ■ F ■ ■ - ■ ...	
		95/127.4	605/445.9	204	340	2900	3100 ⁴⁾	4500	1PH7224-■ ■ U ■ ■ - ■ ...	
130/174.3		828/610.2	278	340	2900	3100 ⁴⁾	4500	1PH7226-■ ■ F ■ ■ - ■ ...		
2500	180	160/214.6	1019/751	350	340	2900	3100 ⁴⁾	4500 ⁴⁾	1PH7228-■ ■ F ■ ■ - ■ ...	
		78/104.6	298/219.6	171	340	5000	3500 ⁴⁾	5000	1PH7184-■ ■ L ■ ■ - ■ ...	
	225	106/142.2	405/298.5	235	335	5000	3500 ⁴⁾	5000	1PH7186-■ ■ L ■ ■ - ■ ...	
		142/190.4	542/399.5	298	340	3500	3100 ⁴⁾	4500	1PH7224-■ ■ L ■ ■ - ■ ...	
168/225.3		642/473.2	362	335	3500	3100 ⁴⁾	4500	1PH7226-■ ■ L ■ ■ - ■ ...		
		205/274.9	783/577.1	433	340	3500	3100 ⁴⁾	4500 ⁴⁾	1PH7228-■ ■ L ■ ■ - ■ ...	
Fan:	External fan unit, heavy-gauge threaded cable entry in terminal box Without external fan unit, for pipe connection, heavy-gauge threaded cable entry in terminal box External fan unit, metric cable entry in terminal box Without external fan unit, for pipe connection, metric cable entry in terminal box								2 6 7 8	
Encoder systems for motors without DRIVE-CLiQ interface:	Without encoder Absolute encoder EnDat 2048 pulses/revolution Incremental encoder HTL 1024 pulses/revolution Incremental encoder HTL 2048 pulses/revolution Incremental encoder sin/cos 1 V _{pp} with C and D tracks ¹¹⁾ Incremental encoder sin/cos 1 V _{pp} without C and D tracks ¹¹⁾ 2-pole resolver								A E H J M N R	
Encoder systems for motors with DRIVE-CLiQ interface:	Absolute encoder EnDat 2048 pulses/revolution Incremental encoder sin/cos 1 V _{pp} with C and D tracks ¹¹⁾ Incremental encoder sin/cos 1 V _{pp} without C and D tracks ¹¹⁾ 2-pole resolver								F D Q P	
Terminal box/cable entry (view onto DE):	Top/from right top/from DE top/from NDE top/from left								0 1 2 3	
Type:	IM B3 IM B5 IM B35 (only for 1PH7184 with flange A400/1PH7186 with flange A450/1PH7 with flange A550) IM B35 (only for 1PH7184 with flange A450) IM B35 (only for 1PH7184 with flange A450/1PH7186 with flange A450/1PH7 with flange A550) IM B35 (only for 1PH7184 with flange A450)								Hoisting concept for other construction types (IM 6, IM B7, IM B8, IM V5, IM V6) Hoisting concept for other construction types (IM V15, IM V35) Hoisting concept for other construction types (IM V15, IM V35)	0 1 3 4 5 6
Holding brake with emergency stop function suitable for coupling output in construction type IM B3)⁵⁾:	Without brake With brake With brake (includes emergency release screws and microswitch) (includes manual release and microswitch)								0 2 4	

Selection and ordering data

Power factor $\cos \varphi$	Magnetizing current I_{μ} A	Efficiency η_{rated}	Rated frequency f_{rated} Hz	Moment of inertia J kgm ² / lb _f -in ²	Weight, approx. kg/lb	1PH7 asynchronous motor	SINAMICS S120 Motor Module	
						Order No.	Rated output current I_{rated} A	Order No.
400 V 3 AC line voltage, Servo Control								
0.84	26	0.830	14.2	0.503/4.452	370/815.85	1PH7184- . . B . . . ■■■■	60	6SL3120- 1 TE26-0AA 1
0.81	38.5	0.845	14.0	0.666/5.895	440/970.2	1PH7186- . . B . . . ■■■■	85	6SL3120- 1 TE28-5AA 1
0.87	36.5	0.864	14.0	1.479/13.09	630/1389.2	1PH7224- . . B . . . ■■■■	85 ⁹⁾	6SL3120- 1 TE28-5AA 1
0.86	49	0.880	14.0	1.930/17.082	750/1653.8	1PH7226- . . B . . . ■■■■	132	6SL3120- 1 TE31-3AA 0
0.85	60.5	0.888	13.9	2.326/19.79	860/1896.3	1PH7228- . . B . . . ■■■■	132 ⁹⁾	6SL3120- 1 TE31-3AA 0
0.83	44	0.913	34.2	0.503/4.452	370/815.85	1PH7184- . . D . . . ■■■■	85 ⁹⁾	6SL3120- 1 TE28-5AA 1
0.81	58	0.918	34.1	0.666/5.895	440/970.2	1PH7186- . . D . . . ■■■■	132	6SL3120- 1 TE31-3AA 0
0.81	78.5	0.934	33.9	1.479/13.09	630/1389.2	1PH7224- . . D . . . ■■■■	200	6SL3120- 1 TE32-0AA 0
0.84	87.5	0.935	33.9	1.930/17.082	750/1653.8	1PH7226- . . D . . . ■■■■	200	6SL3120- 1 TE32-0AA 0
0.85	98	0.938	33.9	2.326/20.587	860/1896.3	1PH7228- . . D . . . ■■■■	260	6SL3120- 1 TE32-1AA 0
0.78	64	0.930	50.7	0.503/4.452	370/815.85	1PH7184- . . F . . . ■■■■	132	6SL3120- 1 TE31-3AA 0
0.81	84	0.937	50.7	0.666/5.895	440/970.2	1PH7186- . . F . . . ■■■■	200	6SL3120- 1 TE32-0AA 0
0.84	88.5	0.944	50.6	1.479/13.09	630/1389.2	1PH7224- . . U . . . ■■■■	200 ⁹⁾	6SL3120- 1 TE32-0AA 0
0.84	120	0.945	50.6	1.930/17.082	750/1653.8	1PH7226- . . F . . . ■■■■	310	6SL3320- 1 TE33-1AA 0
0.82	169	0.949	50.5	2.326/19.79	860/1896.3	1PH7228- . . F . . . ■■■■	380	6SL3320- 1 TE33-8AA 0
0.82	77	0.937	84.1	0.503/4.452	370/815.85	1PH7184- . . L . . . ■■■■	200	6SL3120- 1 TE32-0AA 0
0.82	108	0.942	84.1	0.666/5.895	440/970.2	1PH7186- . . L . . . ■■■■	260	6SL3320- 1 TE32-1AA 0
0.84	115	0.948	84.0	1.479/13.09	630/1389.2	1PH7224- . . L . . . ■■■■	310	6SL3320- 1 TE33-1AA 0
0.84	154	0.950	84.0	1.930/17.082	750/1653.8	1PH7226- . . L . . . ■■■■	380	6SL3320- 1 TE33-8AA 0
0.84	185	0.950	83.9	2.326/19.798	860/1896.3	1PH7228- . . L . . . ■■■■	490	6SL3320- 1 TE35-0AA 0
Output type:	Vibration severity grade:	Shaft and flange accuracy:						
Coupling	R	N		A B C D E F G H J				
Coupling	R	R						
Coupling	S	R						
Coupling	SR	R						
Belt	R	N						
Belt	R	R						
Incr. cantilever forces	R	N						
Incr. cantilever forces	R	R						
Incr. max. speed ⁶⁾	S	R						
Shaft extension (DE):	Balancing:	Direction of air flow (fan):						
Fitted key	Half-key	DE → NDE		A B C D J K				
Fitted key	Half-key	NDE → DE ⁸⁾						
Fitted key	Full-key	DE → NDE						
Fitted key	Full-key	NDE → DE ⁸⁾						
Plain shaft	–	DE → NDE						
Plain shaft	–	NDE → DE ⁸⁾						
Seal:	Paint finish:							
–	Primed			0				
Flange and shaft sealing ring ⁷⁾	Primed			2				
–	Anthracite (RAL 7016), standard paint finish			3				
Flange and shaft sealing ring ⁷⁾	Anthracite (RAL 7016), standard paint finish			5				
–	Anthracite (RAL 7016), special paint finish			6				
Flange and shaft sealing ring ⁷⁾	Anthracite (RAL 7016), special paint finish			8				
Special versions:	Specify supplementary order code and plain text if applicable (see Options).						–Z	

1) n_2 : Max. permissible thermal speed at constant output or speed, which is at the voltage limit when $P = P_{\text{rated}}$.

2) n_{S1} : Max. permissible speed that is continuously permitted without speed duty cycles.

3) n_{max} : Maximum speed which must not be exceeded.

4) Speed is reduced at higher cantilever forces, see selection guides.

5) Model with brake:
12th position "0",
14th position "A",
15th position "A" or "B",
16th position "0", "3" or "6".

6) For shaft height 180 $n_{\text{max}} = 7000$ rpm, 1PH7224: $n_{\text{max}} = 5500$ rpm coupling output only and 16th position "0", "3" or "6".

7) Only appropriate if oil spray/mist occasionally gets onto the sealing ring. A sealing ring is not possible for type IM B3 (IM V5, IM V6), version with increased maximum speed, version with belt drive or increased cantilever forces.

8) Preferred air-flow direction in polluted environment.

9) The rated output current of the Motor Module is lower than the motor rated current.

10) Speed is limited to lower values in some cases. The following restriction applies: Max. output frequency < 5 × motor rated frequency.

11) When ordering option **L27**, please also select option **M84** (insulated version of encoder).

AC motors

Asynchronous motors

1PH7 motors

Selection and ordering data

Rated speed n_{rated} rpm	Shaft height SH	Rated power P_{rated} kW/HP	Rated torque M_{rated} Nm/lb _r -ft	Rated current I_{rated} A	Rated voltage V_{rated} V	Speed during field weakening ¹⁾⁹⁾ n_2 rpm	Max. permissible continuous speed ²⁾ n_{S1} rpm	Max. speed ³⁾ n_{max} rpm	1PH7 asynchronous motor Order No.
400 V 3 AC line voltage, Vector Control									
400	160	9.5/12.7	227/167.3	30	274	2630 ⁹⁾	3700 ⁹⁾	6500 ⁹⁾	1PH7163-■ ■ B ■ ■ -■ ...
		13.0/17.4	310/228.5	37	294	2140 ⁹⁾	3700 ⁹⁾	6500 ⁹⁾	1PH7167-■ ■ B ■ ■ -■ ...
1150	100	4.3/5.8	36/26.5	10	391	2400	5500	9000 ⁹⁾	1PH7103-■ ■ D ■ ■ -■ ...
		7.2/9.7	60/44.2	17.5	360	4170	5500	9000 ⁹⁾	1PH7107-■ ■ D ■ ■ -■ ...
	132	13.5/18.1	112/82.5	29	381	3000	4500	8000 ⁹⁾	1PH7133-■ ■ D ■ ■ -■ ...
		19.5/26.2	162/119.4	43	367	3930	4500	8000 ⁹⁾	1PH7137-■ ■ D ■ ■ -■ ...
	160	25/33.5	208/153.3	55	364	3500	3700	6500 ⁹⁾	1PH7163-■ ■ D ■ ■ -■ ...
		31/41.6	257/189.4	70	357	4840	3700	6500 ⁹⁾	1PH7167-■ ■ D ■ ■ -■ ...
Fan:		External fan unit, heavy-gauge threaded cable entry in terminal box Without external fan unit, for pipe connection, heavy-gauge threaded cable entry in terminal box External fan unit, metric cable entry in terminal box Without external fan unit, for pipe connection, metric cable entry in terminal box							2 6 7 8
Encoder systems for motors without DRIVE-CLiQ interface:		Without encoder Absolute encoder EnDat 2048 pulses/revolution Incremental encoder HTL 1024 pulses/revolution Incremental encoder HTL 2048 pulses/revolution Incremental encoder sin/cos 1 V _{pp} with C and D tracks Incremental encoder sin/cos 1 V _{pp} without C and D tracks 2-pole resolver							A E H J M N R
Encoder systems for motors with DRIVE-CLiQ interface:		Absolute encoder EnDat 2048 pulses/revolution Incremental encoder sin/cos 1 V _{pp} with C and D tracks Incremental encoder sin/cos 1 V _{pp} without C and D tracks 2-pole resolver							F D Q P
Terminal box/cable entry (view onto DE):		Top/from right Top/from NDE Top/from left							0 2 3
Type:		IM B3 (IM V5, IM V6) IM B5 (IM V1, IM V3) available only for shaft heights 100 and 132 IM B35 (IM V15, IM V36)							0 2 3
Holding brake with emergency stop function⁴⁾:		Without brake							0
		Brake supply voltage 230 V 1 AC, 50/60 Hz	With brake With brake (includes microswitch) With brake (includes manual release) With brake (includes manual release and microswitch)						1 2 3 4
		Brake supply voltage 24 V DC	With brake With brake (includes microswitch) With brake (includes manual release) With brake (includes manual release and microswitch)						5 6 7 8

Selection and ordering data

Power factor $\cos \varphi$	Magnetizing current I_{μ} A	Efficiency η_{rated}	Rated frequency f_{rated} Hz	Moment of inertia J kgm ² / lb _r -in ²	Weight, approx. kg/lb	1PH7 asynchronous motor		SINAMICS S120 Motor Module	
						Order No.	Rated output current I_{rated} A	Order No.	
400 V 3 AC line voltage, Vector Control									
0.88	11.5	0.809	14.3	0.185/1.637	175/385.88	1PH7163- . . B . . . ■■■■	30	6SL3120- 1 TE23-0AA 1	
0.88	14.0	0.814	14.3	0.228/2.018	210/463.05	1PH7167- . . B . . . ■■■■	45	6SL3120- 1 TE24-5AA 1	
0.81	5.0	0.813	40.6	0.017/0.15	40/88.2	1PH7103- . . D . . . ■■■■	9 ⁸⁾	6SL3120- ■ TE21-0AA ■	
0.81	8.8	0.838	40.3	0.029/0.257	65/143.33	1PH7107- . . D . . . ■■■■	18	6SL3120- ■ TE21-8AA ■	
0.85	13	0.877	39.7	0.076/0.673	90/198.45	1PH7133- . . D . . . ■■■■	30	6SL3120- 1 TE23-0AA 1	
0.86	19	0.887	39.6	0.109/0.965	150/330.75	1PH7137- . . D . . . ■■■■	45	6SL3120- 1 TE24-5AA 1	
0.84	25	0.904	39.2	0.185/1.637	175/385.88	1PH7163- . . D . . . ■■■■	60	6SL3120- 1 TE26-0AA 1	
0.83	34	0.909	39.1	0.228/2.018	210/463.05	1PH7167- . . D . . . ■■■■	85	6SL3120- 1 TE28-5AA 1	
Output type:		Vibration severity grade:		Shaft and flange accuracy:					
Coupling/belt		R		R		B C D K L			
Coupling/belt		S		R					
Coupling/belt		SR		R					
Coupling/belt		N		N (with brake mounting)					
Increased max. speed ⁵⁾		SR		R					
Shaft extension (DE):		Balancing:		Direction of air flow (fan):					
Fitted key		Half-key		DE → NDE		A B C D J K			
Fitted key		Half-key		NDE → DE ⁷⁾					
Fitted key		Full-key		DE → NDE					
Fitted key		Full-key		NDE → DE ⁷⁾					
Plain shaft		-		DE → NDE					
Plain shaft		-		NDE → DE ⁷⁾					
Seal:		Paint finish:							
-		Without				0			
Flange and shaft sealing ring ⁶⁾		Without				2			
-		Anthracite (RAL 7016), standard paint finish				3			
Flange and shaft sealing ring ⁶⁾		Anthracite (RAL 7016), standard paint finish				5			
-		Anthracite (RAL 7016), special paint finish				6			
Flange and shaft sealing ring ⁶⁾		Anthracite (RAL 7016), special paint finish				8			
Special versions:		Specify supplementary order code and plain text if applicable (see Options).						-Z	
Motor Module:		Single Motor Module						1	
		Double Motor Module						2	
								1	
								0	

- n_2 : Max. permissible thermal speed at constant output or speed, which is at the voltage limit when $P = P_{\text{rated}}$.
- n_{S1} : Max. permissible speed that is continuously permitted without speed duty cycles.
- n_{max} : Maximum speed which must not be exceeded.
- Model with brake possible if:
12th position "2" or "3",
14th position "K",
15th position "A", "B", "J" or "K",
16th position "0", "3" or "6".
- Max. possible speed (see also selection guides):
SH 100: 12000 rpm, SH 132: 10000 rpm, SH 160: 8000 rpm,
with keyless shaft only (15th position "J" or "K" and 16th position "0", "3" or "6").

- Only appropriate if oil spray/mist occasionally gets onto the sealing ring. A sealing ring is not possible for type IM B3 (IM V5, IM V6), or version with increased maximum speed.
- Preferred air-flow direction in polluted environment.
- The rated output current of the Motor Module is lower than the motor rated current.
- Speed is limited to lower values in some cases. The following restriction applies: Max. output frequency < 5 × motor rated frequency.

AC motors

Asynchronous motors

1PH7 motors

Selection and ordering data

Rated speed n_{rated} rpm	Shaft height SH	Rated power P_{rated} kW/HP	Rated torque M_{rated} Nm/lb _r -ft	Rated current I_{rated} A	Rated voltage V_{rated} V	Speed during field weakening ¹⁾ n_2 rpm	Max. permissible continuous speed ²⁾ n_{S1} rpm	Max. speed ³⁾ n_{max} rpm	1PH7 asynchronous motor Order No.	
400 V 3 AC line voltage, Vector Control										
1750	100	4.3/5.8	24/17.7	10	398	6130	5500	9000 ⁹⁾	1PH7101-■ ■ F ■ ■ -■ ...	
		6.3/8.5	34/25.1	13	398	3500	5500	9000 ⁹⁾	1PH7103-■ ■ F ■ ■ -■ ...	
		8/10.7	44/32.4	17.5	398	5940	5500	9000 ⁹⁾	1PH7105-■ ■ F ■ ■ -■ ...	
		10/13.4	55/40.5	23	381	4500	5500	8750	1PH7107-■ ■ F ■ ■ -■ ...	
	132	13/17.4	71/52.3	24	398	4830	4500	8000	1PH7131-■ ■ F ■ ■ -■ ...	
		17.5/23.5	96/70.8	34	398	4990	4500	8000	1PH7133-■ ■ F ■ ■ -■ ...	
		21.5/28.8	117/86.2	42	398	5570	4500	8000	1PH7135-■ ■ F ■ ■ -■ ...	
	160	25/33.5	136/100.2	56	357	4000	4500	8000	1PH7137-■ ■ F ■ ■ -■ ...	
		34/45.6	186/137.1	72	364	4000	3700	6500	1PH7163-■ ■ F ■ ■ -■ ...	
			41/55.0	224/165.1	79	398	2750	3700	6500	1PH7167-■ ■ F ■ ■ -■ ...
2300		100	7.5/10.1	31/22.8	17	388	6000	5500	9000	1PH7103-■ ■ G ■ ■ -■ ...
	12/16.1		50/36.9	26	400	6000	5500	9000	1PH7107-■ ■ G ■ ■ -■ ...	
	132	22.5/30.2	93/68.5	45	398	4000	4500	8000	1PH7133-■ ■ G ■ ■ -■ ...	
		29/38.9	120/88.4	56	398	4000	4500	8000	1PH7137-■ ■ G ■ ■ -■ ...	
	160	38/51.0	158/116.4	82	398	3000	3700	6500	1PH7163-■ ■ G ■ ■ -■ ...	
		44/59.0	183/134.9	85	398	3000	3700	6500	1PH7167-■ ■ G ■ ■ -■ ...	
Fan:		External fan unit, heavy-gauge threaded cable entry in terminal box Without external fan unit, for pipe connection, heavy-gauge threaded cable entry in terminal box External fan unit, metric cable entry in terminal box Without external fan unit, for pipe connection, metric cable entry in terminal box							2 6 7 8	
Encoder systems for motors without DRIVE-CLiQ interface:		Without encoder Absolute encoder EnDat 2048 pulses/revolution Incremental encoder HTL 1024 pulses/revolution Incremental encoder HTL 2048 pulses/revolution Incremental encoder sin/cos 1 V _{pp} with C and D tracks Incremental encoder sin/cos 1 V _{pp} without C and D tracks 2-pole resolver							A E H J M N R	
Encoder systems for motors with DRIVE-CLiQ interface:		Absolute encoder EnDat 2048 pulses/revolution Incremental encoder sin/cos 1 V _{pp} with C and D tracks Incremental encoder sin/cos 1 V _{pp} without C and D tracks 2-pole resolver							F D Q P	
Terminal box/cable entry (view onto DE):		Top/from right Top/from NDE Top/from left							0 2 3	
Type:		IM B3 (IM V5, IM V6) IM B5 (IM V1, IM V3) available only for shaft heights 100 and 132 IM B35 (IM V15, IM V36)							0 2 3	
Holding brake with emergency stop function⁴⁾:		Without brake Brake supply voltage 230 V 1 AC, 50/60 Hz With brake With brake (includes microswitch) With brake (includes manual release) With brake (includes manual release and microswitch) Brake supply voltage 24 V DC With brake With brake (includes microswitch) With brake (includes manual release) With brake (includes manual release and microswitch)							0 1 2 3 4 5 6 7 8	



Selection and ordering data

Power factor $\cos \varphi$	Magnetizing current I_{μ} A	Efficiency η_{rated}	Rated frequency f_{rated} Hz	Moment of inertia of J kgm ² / lb _f -in-s ²	Weight, approx. kg/lb	1PH7 asynchronous motor		SINAMICS S120 Motor Module		
						Order No.	I_{rated} A	Rated output current	Order No.	
400 V 3 AC line voltage, Vector Control										
0.75	5.7	0.855	60.0	0.017/0.15	40/88.2	1PH7101- . . . F . . . ■■■■	9 ⁸⁾	6SL3120- ■ TE21-0AA ■		
0.84	5.3	0.849	61.0	0.017/0.15	40/88.2	1PH7103- . . . F . . . ■■■■	18	6SL3120- ■ TE21-8AA ■		
0.77	9.3	0.875	60.0	0.029/0.257	65/143.33	1PH7105- . . . F . . . ■■■■	18	6SL3120- ■ TE21-8AA ■		
0.80	10.6	0.870	60.3	0.029/0.257	65/143.33	1PH7107- . . . F . . . ■■■■	30	6SL3120- 1 TE23-0AA 1		
0.88	8.1	0.902	59.7	0.076/0.673	90/198.45	1PH7131- . . . F . . . ■■■■	30	6SL3120- 1 TE23-0AA 1		
0.85	14	0.900	59.7	0.076/0.673	90/198.45	1PH7133- . . . F . . . ■■■■	45	6SL3120- 1 TE24-5AA 1		
0.86	16	0.906	59.5	0.109/0.965	150/330.8	1PH7135- . . . F . . . ■■■■	45	6SL3120- 1 TE24-5AA 1		
0.85	23	0.902	59.5	0.109/0.965	150/330.8	1PH7137- . . . F . . . ■■■■	60	6SL3120- 1 TE26-0AA 1		
0.86	28	0.915	59.2	0.185/1.637	175/385.9	1PH7163- . . . F . . . ■■■■	85	6SL3120- 1 TE28-5AA 1		
0.86	30	0.920	59.2	0.228/2.018	210/463.1	1PH7167- . . . F . . . ■■■■	85	6SL3120- 1 TE28-5AA 1		
0.79	8.2	0.866	78.8	0.017/0.15	40/88.2	1PH7103- . . . G . . . ■■■■	18	6SL3120- ■ TE21-8AA ■		
0.80	12	0.878	78.7	0.029/0.257	65/143.33	1PH7107- . . . G . . . ■■■■	30	6SL3120- 1 TE23-0AA 1		
0.86	17	0.900	78.0	0.076/0.673	90/198.45	1PH7133- . . . G . . . ■■■■	45	6SL3120- 1 TE24-5AA 1		
0.87	21	0.903	77.8	0.109/0.965	150/330.8	1PH7137- . . . G . . . ■■■■	60	6SL3120- 1 TE26-0AA 1		
0.83	43	0.900	77.3	0.185/1.637	175/385.9	1PH7163- . . . G . . . ■■■■	85	6SL3120- 1 TE28-5AA 1		
0.84	40	0.911	77.4	0.228/2.018	210/463.1	1PH7167- . . . G . . . ■■■■	85	6SL3120- 1 TE28-5AA 1		
Output type:		Vibration severity grade:		Shaft and flange accuracy:						
Coupling/belt		R		R		B				
Coupling/belt		S		R		C				
Coupling/belt		SR		R		D				
Coupling/belt		N		N (with brake mounting)		K				
Increased max. speed ⁵⁾		SR		R		L				
Shaft extension (DE):		Balancing:		Direction of air flow (fan):						
Fitted key		Half-key		DE → NDE		A				
Fitted key		Half-key		NDE → DE ⁷⁾		B				
Fitted key		Full-key		DE → NDE		C				
Fitted key		Full-key		NDE → DE ⁷⁾		D				
Plain shaft		-		DE → NDE		J				
Plain shaft		-		NDE → DE ⁷⁾		K				
Seal:		Paint finish:								
-		Without				0				
Flange and shaft sealing ring ⁶⁾		Without				2				
-		Anthracite (RAL 7016), standard paint finish				3				
Flange and shaft sealing ring ⁶⁾		Anthracite (RAL 7016), standard paint finish				5				
-		Anthracite (RAL 7016), special paint finish				6				
Flange and shaft sealing ring ⁶⁾		Anthracite (RAL 7016), special paint finish				8				
Special versions:		Specify supplementary order code and plain text if applicable (see Options).					-Z			
Motor Module:		Single Motor Module					1			
		Double Motor Module					2 0			

- n_2 : Max. permissible thermal speed at constant output or speed, which is at the voltage limit when $P = P_{\text{rated}}$.
- n_{S1} : Max. permissible speed that is continuously permitted without speed duty cycles.
- n_{max} : Maximum speed which must not be exceeded.
- Model with brake possible if:
12th position "2" or "3",
14th position "K",
15th position "A", "B", "J" or "K",
16th position "0", "3" or "6".
- Max. possible speed (see also selection guides):
SH 100: 12000 rpm, SH 132: 10000 rpm, SH 160: 8000 rpm,
with keyless shaft only (15th position "J" or "K" and 16th position "0", "3" or "6").

- Only appropriate if oil spray/mist occasionally gets onto the sealing ring. A sealing ring is not possible for type IM B3 (IM V5, IM V6), or version with increased maximum speed.
- Preferred air-flow direction in polluted environment.
- The rated output current of the Motor Module is lower than the motor rated current.
- Speed is limited to lower values in some cases. The following restriction applies: Max. output frequency < 5 × motor rated frequency.

AC motors

Asynchronous motors

1PH7 motors

Selection and ordering data

Rated speed	Shaft height SH	Rated power	Rated torque	Rated current	Rated voltage	Speed during field weakening ¹⁾	Max. perm. continuous speed ²⁾	Max. speed ³⁾	1PH7 asynchronous motor
n_{rated} rpm		P_{rated} kW/HP	M_{rated} Nm/lb _r -ft	I_{rated} A	V_{rated} V	n_2 rpm	n_{S1} rpm	n_{max} rpm	Order No.
400 V 3 AC line voltage, Vector Control									
400	180	16.3/21.9	390/287.4	51	271	2900 ¹¹⁾	3500 ⁴⁾¹¹⁾	5000 ¹¹⁾	1PH7184-■ ■ B ■ ■ -■ ...
		21.2/28.4	505/372.2	67	268	3300 ¹¹⁾	3500 ⁴⁾¹¹⁾	5000 ¹¹⁾	1PH7186-■ ■ B ■ ■ -■ ...
	225	30.4/40.8	725/534.3	88	268	2700 ¹¹⁾	3100 ⁴⁾¹¹⁾	4500 ¹¹⁾	1PH7224-■ ■ B ■ ■ -■ ...
		39.2/52.6	935/689.1	114	264	2900 ¹¹⁾	3100 ⁴⁾¹¹⁾	4500 ¹¹⁾	1PH7226-■ ■ B ■ ■ -■ ...
		48/64.4	1145/843.9	136	272	2900 ¹¹⁾	3100 ⁴⁾¹¹⁾	4500 ⁴⁾¹¹⁾	1PH7228-■ ■ B ■ ■ -■ ...
1150	180	44/6	366/269.7	89	383	4200	3500 ⁴⁾	5000	1PH7184-■ ■ D ■ ■ -■ ...
		58/77.8	482/355.2	116	390	4400	3500 ⁴⁾	5000	1PH7186-■ ■ D ■ ■ -■ ...
	225	81/108.6	670/493.8	160	385	2900	3100 ⁴⁾	4500	1PH7224-■ ■ D ■ ■ -■ ...
		105/140.8	870/641.2	197	390	2900	3100 ⁴⁾	4500	1PH7226-■ ■ D ■ ■ -■ ...
		129/173.0	1070/788.6	238	390	2900	3100 ⁴⁾	4500 ⁴⁾	1PH7228-■ ■ D ■ ■ -■ ...
Fan:	External fan unit, PG cable entry in terminal box Without external fan unit, for pipe connection, PG cable entry in terminal box External fan unit, metric cable entry in terminal box Without external fan unit, for pipe connection, metric cable entry in terminal box								2 6 7 8
Encoder systems for motors without DRIVE-CLiQ interface:	Without encoder Absolute encoder EnDat 2048 pulses/revolution Incremental encoder HTL 1024 pulses/revolution Incremental encoder HTL 2048 pulses/revolution Incremental encoder sin/cos 1 V_{pp} with C and D tracks ¹⁰⁾ Incremental encoder sin/cos 1 V_{pp} without C and D tracks ¹⁰⁾ 2-pole resolver								A E H J M N R
Encoder systems for motors with DRIVE-CLiQ interface:	Absolute encoder EnDat 2048 pulses/revolution Incremental encoder sin/cos 1 V_{pp} with C and D tracks ¹⁰⁾ Incremental encoder sin/cos 1 V_{pp} without C and D tracks ¹⁰⁾ 2-pole resolver								F D Q P
Terminal box/cable entry (view onto DE):	top/from right top/from DE top/from NDE top/from left								0 1 2 3
Type:	IM B3 IM B3 Hoisting system for different construction types (IM B6, IM B7, IM B8, IM V5, IM V6) IM B35 (only for 1PH7184 with flange A 400, 1PH7186 with flange A 450, 1PH722. with flange A 550) IM B35 (only for 1PH7184 with flange A 450) IM B35 (only for 1PH7184 with flange A 400, 1PH7186 with flange A 450, 1PH722. with flange A 550) IM B35 (only for 1PH7184 with flange A 450) Hoisting system for different construction types (IM V15, IM V36) IM B35 (only for 1PH7184 with flange A 450) Hoisting system for different construction types (IM V15, IM V36)								0 1 3 4 5 6
Holding brake with emergency stop function (suitable for coupling output in construction type IM B3) ⁵⁾:	Without brake With brake (includes emergency release screws and microswitch) With brake (includes manual release and microswitch)								0 2 4

Selection and ordering data

Power factor $\cos \varphi$	Magnetizing current I_M A	Efficiency η_{rated}	Rated frequency f_{rated} Hz	Moment of inertia of J kgm ² / lb _r -in-s ²	Weight, approx. kg/lb	1PH7 asynchronous motor	SINAMICS S120 Motor Module Rated output current	
						Order No.	I_{rated} A	Order No.
400 V 3 AC line voltage, Vector Control								
0.84	26	0.830	14.2	0.503/4.452	370/815.9	1PH7184- . . B ■■■■	60	6SL3120-1TE26-0AA1
0.81	38.5	0.845	14.0	0.666/5.895	440/970.2	1PH7186- . . B ■■■■	85	6SL3120-1TE28-5AA1
0.87	36.5	0.864	14.0	1.479/13.09	630/1389.2	1PH7224- . . B ■■■■	85 ⁹⁾	6SL3120-1TE28-5AA1
0.86	49	0.880	14.0	1.930/17.08	750/1653.8	1PH7226- . . B ■■■■	132	6SL3120-1TE31-3AA0
0.85	60.5	0.888	13.9	2.326/19.79	860/1896.3	1PH7228- . . B ■■■■	132 ⁹⁾	6SL3120-1TE31-3AA0
0.82	42	0.920	39.2	0.503/4.452	370/815.9	1PH7184- . . D ■■■■	85 ⁹⁾	6SL3120-1TE28-5AA1
0.81	58	0.925	39.1	0.666/5.895	440/970.2	1PH7186- . . D ■■■■	132	6SL3120-1TE31-3AA0
0.81	79	0.938	38.9	1.479/13.09	630/1389.2	1PH7224- . . D ■■■■	200	6SL3120-1TE32-0AA0
0.84	87.5	0.941	38.9	1.930/17.08	750/1653.8	1PH7226- . . D ■■■■	200	6SL3120-1TE32-0AA0
0.85	98	0.943	38.9	2.326/19.79	860/1896.3	1PH7228- . . D ■■■■	260	6SL3320-1TE32-6AA0
Output type:		Vibration severity grade:		Shaft and flange accuracy:				
Coupling		R		N		A		
Coupling		R		R		B		
Coupling		S		R		C		
Coupling		SR		R		D		
Belt		R		N		E		
Belt		R		R		F		
Incr. cantilever forces		R		N		G		
Incr. cantilever forces		R		R		H		
Increased max. speed ⁶⁾		S		R		J		
Shaft extension (DE):		Balancing:		Direction of air flow (fan):				
Fitted key		Half-key		DE → NDE		A		
Fitted key		Half-key		NDE → DE ⁸⁾		B		
Fitted key		Full-key		DE → NDE		C		
Fitted key		Full-key		NDE → DE ⁸⁾		D		
Plain shaft		–		DE → NDE		J		
Plain shaft		–		NDE → DE ⁸⁾		K		
Seal:		Paint finish:						
–		Primed				0		
Flange and shaft sealing ring ⁷⁾		Primed				2		
–		Anthracite (RAL 7016), standard paint finish				3		
Flange and shaft sealing ring ⁷⁾		Anthracite (RAL 7016), standard paint finish				5		
–		Anthracite (RAL 7016), special paint finish				6		
Flange and shaft sealing ring ⁷⁾		Anthracite (RAL 7016), special paint finish				8		
Special versions:		Specify supplementary order code and plain text if applicable (see Options).						–Z

- n_2 : Max. permissible thermal speed at constant output or speed, which is at the voltage limit when $P = P_{rated}$.
- n_{S1} : Max. permissible speed that is continuously permitted without speed duty cycles.
- n_{max} : Maximum speed which must not be exceeded.
- Speed is reduced with increased cantilever forces; see selection guides.
- Model with brake: 12th position "0", 14th position "A", 15th position "A" or "B", 16th position "0", "3" or "6".
- For shaft height 180 $n_{max} = 7000$ rpm, 1PH7 224 $n_{max} = 5500$ rpm, only coupling output possible and 16th position "0", "3" or "6".

- Only appropriate if oil spray/mist occasionally gets onto the sealing ring. A sealing ring is not possible for type IM B3 (IM V5, IM V6), version with increased maximum speed, version for belt output or increased cantilever forces.
- Preferred air-flow direction in polluted environment.
- The rated output current of the Motor Module is lower than the motor rated current.
- When ordering option **L27**, please also select option **M84** (insulated version of encoder).
- Speed is limited to lower values in some cases. The following restriction applies: Max. output frequency < 5 × motor rated frequency.

AC motors

Asynchronous motors

1PH7 motors

Selection and ordering data

Rated speed	Shaft height SH	Rated power	Rated torque	Rated current	Rated voltage	Speed during field weakening ¹⁾	Max. perm. continuous speed ²⁾	Max. speed ³⁾	1PH7 asynchronous motor
n_{rated} rpm		P_{rated} kW/HP	M_{rated} Nm/lb _f -ft	I_{rated} A	V_{rated} V	n_2 rpm	n_{S1} rpm	n_{max} rpm	Order No.
400 V 3 AC line voltage, Vector Control									
1750	180	60/80.5	327/241	120	388	5000	3500 ⁴⁾	5000	1PH7184-■ ■ F ■ ■ -■ ...
		85/114.0	465/342.7	169	385	5000	3500 ⁴⁾	5000	1PH7186-■ ■ F ■ ■ -■ ...
	225	110/147.5	600/442.2	203	395	2900	3100 ⁴⁾	4500	1PH7224-■ ■ U ■ ■ -■ ...
		135/181.0	737/543.2	254	395	2900	3100 ⁴⁾	4500	1PH7226-■ ■ F ■ ■ -■ ...
		179/240.0	975/718.6	342	395	2900	3100 ⁴⁾	4500 ⁴⁾	1PH7228-■ ■ F ■ ■ -■ ...
2900	180	81/108.6	265/193.5	158	395	5000	3500 ⁴⁾	5000	1PH7184-■ ■ L ■ ■ -■ ...
		101/135.4	333/245.4	206	385	5000	3500 ⁴⁾	5000	1PH7186-■ ■ L ■ ■ -■ ...
	225	149/199.8	490/361.1	274	395	3500	3100 ⁴⁾	4500	1PH7224-■ ■ L ■ ■ -■ ...
		185/248.1	610/449.6	348	390	3500	3100 ⁴⁾	4500	1PH7226-■ ■ L ■ ■ -■ ...
		215/288.3	708/521.8	402	395	3500	3100 ⁴⁾	4500 ⁴⁾	1PH7228-■ ■ L ■ ■ -■ ...
Fan:	External fan unit, PG cable entry in terminal box Without external fan unit, for pipe connection, PG cable entry in terminal box External fan unit, metric cable entry in terminal box Without external fan unit, for pipe connection, metric cable entry in terminal box								2 6 7 8
Encoder systems for motors without DRIVE-CLiQ interface:	Without encoder Absolute encoder EnDat 2048 pulses/revolution Incremental encoder HTL 1024 pulses/revolution Incremental encoder HTL 2048 pulses/revolution Incremental encoder sin/cos 1 V_{pp} with C and D tracks ¹⁰⁾ Incremental encoder sin/cos 1 V_{pp} without C and D tracks ¹⁰⁾ 2-pole resolver								A E H J M N R
Encoder systems for motors with DRIVE-CLiQ interface:	Absolute encoder EnDat 2048 pulses/revolution Incremental encoder sin/cos 1 V_{pp} with C and D tracks ¹⁰⁾ Incremental encoder sin/cos 1 V_{pp} without C and D tracks ¹⁰⁾ 2-pole resolver								F D Q P
Terminal box/cable entry (view onto DE):	top/from right top/from DE top/from NDE top/from left								0 1 2 3
Type:	IM B3 IM B3 IM B35 (only for 1PH7184 with flange A 400, 1PH7186 with flange A 450, 1PH722. with flange A 550) IM B35 (only for 1PH7184 with flange A 450) IM B35 (only for 1PH7184 with flange A 400, 1PH7186 with flange A 450, 1PH722. with flange A 550) IM B35 (only for 1PH7184 with flange A 450)								0 1 3 4 5 6
Holding brake with emergency stop function (suitable for coupling output in construction type IM B3) ⁵⁾:	Without brake With brake (includes emergency release screws and microswitch) With brake (includes manual release and microswitch)								0 2 4

Selection and ordering data

Power factor $\cos \varphi$	Magnetizing current I_{μ} A	Efficiency η_{rated}	Rated frequency f_{rated} Hz	Moment of inertia of J kgm ² / lb _r -in-s ²	Weight, approx. kg/lb	1PH7 asynchronous motor		SINAMICS S120 Motor Module	
						Order No.		Rated output current I_{rated} A	Order No.
400 V 3 AC line voltage, Vector Control									
0.78	64	0.934	59.0	0.503/4.452	370/815.85	1PH7184- . . F . . . ■■■		132	6SL3120-1 TE31-3AA0
0.80	84	0.940	59.0	0.666/5.895	440/970.2	1PH7186- . . F . . . ■■■		200	6SL3120-1 TE32-0AA0
0.84	88	0.944	58.9	1.479/13.09	630/1389.2	1PH7224- . . U . . . ■■■		200 ⁹⁾	6SL3120-1 TE32-0AA0
0.82	120	0.947	58.9	1.930/17.082	750/1653.8	1PH7226- . . F . . . ■■■		260	6SL3320-1 TE32-6AA0
0.81	169	0.948	58.8	2.326/19.79	860/1896.3	1PH7228- . . F . . . ■■■		380	6SL3320-1 TE33-8AA0
0.80	77	0.934	97.4	0.503/4.452	370/815.85	1PH7184- . . L . . . ■■■		200	6SL3120-1 TE32-0AA0
0.78	107	0.936	97.3	0.666/5.895	440/970.2	1PH7186- . . L . . . ■■■		200 ⁹⁾	6SL3120-1 TE32-0AA0
0.84	115	0.946	97.3	1.479/13.09	630/1389.2	1PH7224- . . L . . . ■■■		310	6SL3320-1 TE33-1AA0
0.83	154	0.946	97.2	1.930/17.082	750/1653.8	1PH7226- . . L . . . ■■■		380	6SL3320-1 TE33-8AA0
0.82	186	0.946	97.2	2.326/19.79	860/1896.3	1PH7228- . . L . . . ■■■		490	6SL3320-1 TE35-0AA0
Output type:		Vibration severity grade:		Shaft and flange accuracy:					
Coupling		R		N		A B C D E F G H J A B C D J K 0 2 3 5 6 8 -Z			
Coupling		R		R					
Coupling		S		R					
Coupling		SR		R					
Belt		R		N					
Belt		R		R					
Incr. cantilever forces		R		N					
Incr. cantilever forces		R		R					
Increased max. speed ⁶⁾		S		R					
Shaft extension (DE):		Balancing:		Direction of air flow (fan):					
Fitted key		Half-key		DE → NDE					
Fitted key		Half-key		NDE → DE ⁸⁾					
Fitted key		Full-key		DE → NDE					
Fitted key		Full-key		NDE → DE ⁸⁾					
Plain shaft		-		DE → NDE					
Plain shaft		-		NDE → DE ⁸⁾					
Seal:		Paint finish:							
-		Primed							
Flange and shaft sealing ring ⁷⁾		Primed							
-		Anthracite (RAL 7016), standard paint finish							
Flange and shaft sealing ring ⁷⁾		Anthracite (RAL 7016), standard paint finish							
-		Anthracite (RAL 7016), special paint finish							
Flange and shaft sealing ring ⁷⁾		Anthracite (RAL 7016), special paint finish							
Special versions:		Specify supplementary order code and plain text if applicable (see Options).							

- n_2 : Max. permissible thermal speed at constant output or speed, which is at the voltage limit when $P = P_{\text{rated}}$.
- n_{S1} : Max. permissible speed that is continuously permitted without speed duty cycles.
- n_{max} : Maximum speed which must not be exceeded.
- Speed is reduced with increased cantilever forces; see selection guides.
- Model with brake: 12th position "0", 14th position "A", 15th position "A" or "B", 16th position "0", "3" or "6".
- For shaft height 180 $n_{\text{max}} = 7000$ rpm, 1PH7 224 $n_{\text{max}} = 5500$ rpm, only coupling output possible and 16th position "0", "3" or "6".

- Only appropriate if oil spray/mist occasionally gets onto the sealing ring. A sealing ring is not possible for type IM B3 (IM V5, IM V6), version with increased maximum speed, version for belt output or increased cantilever forces.
- Preferred air-flow direction in polluted environment.
- The rated output current of the Motor Module is lower than the motor rated current.
- When ordering option **L27**, please also select option **M84** (insulated version of encoder).

AC motors

Asynchronous motors

1PH7 motors

Selection and ordering data

Rated speed	Shaft height SH	Rated power	Rated torque	Rated current	Rated voltage	Speed during field weakening ¹⁾	Max. permissible continuous speed ²⁾	Max. speed ³⁾	1PH7 asynchronous motor
n_{rated} rpm		P_{rated} kW/HP	M_{rated} Nm/lb _f -ft	I_{rated} A	V_{rated} V	n_2 rpm	n_{S1} rpm	n_{max} rpm	Order No.
400 V 3 AC line voltage, Vector Control									
500	280	80/107.3	1529/1126.9	144	400	1700	2200	3300 ⁷⁾	1PH7 284- ■ ■ B ■ ■ - 0 ...
		100/134.1	1909/1406.9	180	400	1800	2200	3300 ⁷⁾	1PH7 286- ■ ■ B ■ ■ - 0 ...
		130/174.3	2481/1828.5	233	400	1800	2200	3300 ⁷⁾	1PH7 288- ■ ■ B ■ ■ - 0 ...
800	280	125/167.6	1492/1099.6	220	400	2200	2200	3300	1PH7 284- ■ ■ C ■ ■ - 0 ...
		155/207.9	1850/1363.5	285	385	2200	2200	3300	1PH7 286- ■ ■ C ■ ■ - 0 ...
		190/254.8	2268/1671.5	365	370	2200	2200	3300	1PH7 288- ■ ■ C ■ ■ - 0 ...
1150	280	170/228.0	1414/1042.1	314	400	2200	2200	3300	1PH7 284- ■ ■ D ■ ■ - 0 ...
		210/281.6	1745/1286.1	414	380	2200	2200	3300	1PH7 286- ■ ■ D ■ ■ - 0 ...
		260/348.7	2160/1591.9	497	385	2200	2200	3300	1PH7 288- ■ ■ D ■ ■ - 0 ...
1750	280	225/301.7	1228/905	393	400	2200	2200	3300	1PH7 284- ■ ■ F ■ ■ - 0 ...
		270/362.1	1474/1086.3	466	400	2200	2200	3300	1PH7 286- ■ ■ F ■ ■ - 0 ...
		340/455.9	1856/1367.9	586	400	2200	2200	3300	1PH7 288- ■ ■ F ■ ■ - 0 ...
Fans ⁴⁾:	External fan unit, NDE at top, air-flow direction NDE to DE External fan unit, NDE on right, air-flow direction NDE to DE External fan unit, NDE on left, air-flow direction NDE to DE External fan unit, DE at top, air-flow direction DE to NDE External fan unit, DE on right, air-flow direction DE to NDE External fan unit, DE on left, air-flow direction DE to NDE Without external fan unit, for single pipe connection at NDE on right								0 1 2 3 4 5 6
Encoder systems for motors without DRIVE-CLiQ interface:	Without encoder Absolute encoder EnDat 2048 pulses/revolution Incremental encoder HTL 1024 pulses/revolution Incremental encoder HTL 2048 pulses/revolution Incremental encoder sin/cos 1 V _{pp} with C and D tracks ⁶⁾ Incremental encoder sin/cos 1 V _{pp} without C and D tracks ⁶⁾ 2-pole resolver								A E H J M N R
Encoder systems for motors with DRIVE-CLiQ interface:	Absolute encoder EnDat 2048 pulses/revolution Incremental encoder sin/cos 1 V _{pp} with C and D tracks ⁶⁾ Incremental encoder sin/cos 1 V _{pp} without C and D tracks ⁶⁾ 2-pole resolver								F D Q P
Terminal box/cable entry (view onto DE) ⁴⁾:	NDE right/from below/encoder connector DE NDE left/from below/encoder connector DE NDE top/from right/encoder connector DE DE top/from right/encoder connector NDE								0 1 2 5
Type ⁴⁾:	IM B3 IM V5 (can be subsequently modified to IM V6) IM B35 (with flange A 660) IM V15 (with flange A 660, can be subsequently modified to IM V36)								0 1 3 5



Selection and ordering data

Power factor $\cos \varphi$	Magnetizing current I_M A	Efficiency η_{rated}	Rated frequency f_{rated} Hz	Moment of inertia of J kgm ² / lb _f -in-s ²	Weight, approx. kg/lb	1PH7 asynchronous motor	SINAMICS S120 Motor Module Rated output current	
						Order No.	I_{rated} A	Order No.
400 V 3 AC line voltage, Vector Control								
0.87	60	0.922	17	4.2/37.17	1300/2866.5	1PH7284- . . B . . -0 ■■■	200	6SL3120-1 TE32-0AA0
0.86	78	0.930	17	5.2/46.02	1500/3307.5	1PH7286- . . B . . -0 ■■■	200	6SL3120-1 TE32-0AA0
0.87	100	0.933	17	6.3/55.76	1700/3748.5	1PH7288- . . B . . -0 ■■■	260	6SL3320-1 TE32-6AA0
0.86	95	0.944	27	4.2/37.17	1300/2866.5	1PH7284- . . C . . -0 ■■■	260	6SL3320-1 TE32-6AA0
0.85	135	0.948	27	5.2/46.02	1500/3307.5	1PH7286- . . C . . -0 ■■■	310	6SL3320-1 TE33-1AA0
0.84	170	0.951	27	6.3/55.76	1700/3748.5	1PH7288- . . C . . -0 ■■■	380	6SL3320-1 TE33-8AA0
0.82	158	0.956	38.6	4.2/37.17	1300/2866.5	1PH7284- . . D . . -0 ■■■	310 ⁵⁾	6SL3320-1 TE33-1AA0
0.81	218	0.958	38.6	5.2/46.02	1500/3307.5	1PH7286- . . D . . -0 ■■■	490	6SL3320-1 TE35-0AA0
0.82	252	0.960	38.6	6.3/55.76	1700/3748.5	1PH7288- . . D . . -0 ■■■	490 ⁵⁾	6SL3320-1 TE35-0AA0
0.86	163	0.962	58.7	4.2/37.17	1300/2866.5	1PH7284- . . F . . -0 ■■■	490	6SL3320-1 TE35-0AA0
0.87	184	0.963	58.7	5.2/46.02	1500/3307.5	1PH7286- . . F . . -0 ■■■	490	6SL3320-1 TE35-0AA0
0.87	234	0.965	58.7	6.3/55.76	1700/3748.5	1PH7288- . . F . . -0 ■■■	605	6SL3320-1 TE36-1AA0
Output type ⁴⁾:		Vibration severity grade:		Shaft and flange accuracy:				
Coupling		N		N		A B E F		
Coupling		R		R				
Belt/incr. cantilever forces		N		N				
Belt/incr. cantilever forces		R		R				
Shaft extension (DE):		Balancing:				A C J		
Fitted key		Half-key						
Fitted key		Full-key						
Plain shaft		-				0 3 6		
Paint finish:								
Primed								
Anthracite (RAL 7016), standard paint finish						-Z		
Anthracite (RAL 7016), special paint finish								
Special versions:		Specify supplementary order code and plain text if applicable (see Options).						

1) n_2 : Max. permissible thermal speed at constant output or speed, which is at the voltage limit when $P = P_{rated}$.

2) n_{S1} : Max. permissible speed that is continuously permitted without speed duty cycles.

3) n_{max} : Maximum speed which must not be exceeded.

4) See Table "Permissible combinations of mechanical designs".

5) The rated output current of the Motor Module is lower than the motor rated current.

6) When ordering option **L27**, please also select option **M84** (insulated version of encoder).

7) Speed is limited to lower values in some cases. The following restriction applies: Max. output frequency < 5 × motor rated frequency.

AC motors

Asynchronous motors

1PH7 motors

Selection and ordering data

Rated speed n_{rated} rpm	Shaft height SH	Rated power P_{rated} kW/HP	Rated torque M_{rated} Nm/lb _f -ft	Rated current I_{rated} A	Rated voltage V_{rated} V	Speed during field weakening ¹⁾ n_2 rpm	Max. permissible continuous speed ²⁾ n_{S1} rpm	Max. speed ³⁾ n_{max} rpm	1PH7 asynchronous motor Order No.
480 V 3 AC line voltage, Servo/Vector Control									
500	160	12/16.1	230/169.5	30	340	2840 ⁸⁾	3700 ⁸⁾	6500 ⁸⁾	1PH7163-■ ■ B ■ ■ -■ ...
		16/21.5	306/225.5	35	350	2380 ⁸⁾	3700 ⁸⁾	6500 ⁸⁾	1PH7167-■ ■ B ■ ■ -■ ...
1350	100	4.7/6.3	33/24.3	9.5	433	3500	5500	9000 ⁸⁾	1PH7103-■ ■ D ■ ■ -■ ...
		8/10.7	57/42	17	405	5160	5500	9000 ⁸⁾	1PH7107-■ ■ D ■ ■ -■ ...
	132	15/20.1	106/78.1	30	433	3500	4500	8000 ⁸⁾	1PH7133-■ ■ D ■ ■ -■ ...
		22/29.5	156/115	42	416	4750	4500	8000 ⁸⁾	1PH7137-■ ■ D ■ ■ -■ ...
	160	28/37.6	198/145.9	53	413	4000	3700	6500	1PH7163-■ ■ D ■ ■ -■ ...
		34/45.6	241/177.6	67	400	5900	3700	6500	1PH7167-■ ■ D ■ ■ -■ ...
Fans:		External fan unit, heavy-gauge threaded cable entry in terminal box Without external fan unit, for pipe connection, heavy-gauge threaded cable entry in terminal box External fan unit, metric cable entry in terminal box Without external fan unit, for pipe connection, metric cable entry in terminal box							2 6 7 8
Encoder systems for motors without DRIVE-CLiQ interface:		Without encoder Absolute encoder EnDat 2048 pulses/revolution Incremental encoder HTL 1024 pulses/revolution Incremental encoder HTL 2048 pulses/revolution Incremental encoder sin/cos 1 V _{pp} with C and D tracks Incremental encoder sin/cos 1 V _{pp} without C and D tracks 2-pole resolver							A E H J M N R
Encoder systems for motors with DRIVE-CLiQ interface:		Absolute encoder EnDat 2048 pulses/revolution Incremental encoder sin/cos 1 V _{pp} with C and D tracks Incremental encoder sin/cos 1 V _{pp} without C and D tracks 2-pole resolver							F D Q P
Terminal box/cable entry (view onto DE):		Top/from right Top/from NDE Top/from left							0 2 3
Type:		IM B3 (IM V5, IM V6) IM B5 (IM V1, IM V3) available only for shaft heights 100 and 132 IM B35 (IM V15, IM V36)							0 2 3
Holding brake with emergency stop function ⁴⁾:		Without brake							0
		Brake supply voltage 230 V 1 AC, 50/60 Hz		With brake With brake (includes microswitch) With brake (includes manual release) With brake (includes manual release and microswitch)				1 2 3 4	
		Brake supply voltage 24 V DC V		With brake With brake (includes microswitch) With brake (includes manual release) With brake (includes manual release and microswitch)				5 6 7 8	

Selection and ordering data

Power factor $\cos \varphi$	Magnetizing current I_{μ} A	Efficiency η_{rated}	Rated frequency f_{rated} Hz	Moment of inertia of J kgm ² /lb _f -in-s ²	Weight, approx. kg/lb	1PH7 asynchronous motor		SINAMICS S120 Motor Module Rated output current	
						Order No.	I_{rated} A	Order No.	
Netzspannung 3 AC 480 V, Servo/Vector Control									
0.86	13	0.841	17.6	0.185/1.637	175/385.9	1PH7163- . . B . . . ■■■■	30	6SL3120- 1 TE23-0AA 1	
0.89	13	0.836	17.7	0.228/2.018	210/463.05	1PH7167- . . B . . . ■■■■	45	6SL3120- 1 TE24-5AA 1	
0.81	4.5	0.830	47.1	0.017/0.15	40/88.2	1PH7103- . . D . . . ■■■■	18	6SL3120- ■ TE21-8AA ■	
0.80	8.1	0.853	47.0	0.029/0.257	65/143.33	1PH7107- . . D . . . ■■■■	18	6SL3120- ■ TE21-8AA ■	
0.84	12	0.887	46.4	0.076/0.673	90/198.45	1PH7133- . . D . . . ■■■■	30	6SL3120- 1 TE23-0AA 1	
0.85	17	0.895	46.3	0.109/0.965	150/330.75	1PH7137- . . D . . . ■■■■	45	6SL3120- 1 TE24-5AA 1	
0.83	24	0.911	45.8	0.185/1.637	175/385.9	1PH7163- . . D . . . ■■■■	60	6SL3120- 1 TE26-0AA 1	
0.83	34	0.910	45.8	0.228/2.018	210/463.05	1PH7167- . . D . . . ■■■■	85	6SL3120- 1 TE28-5AA 1	
Output type:		Vibration severity grade:		Shaft and flange accuracy:					
Coupling/belt		R		R		B C D K L			
Coupling/belt		S		R					
Coupling/belt		SR		R					
Coupling/belt		N		N (with brake mounting)					
Increased maximum speed ⁵⁾		SR		R					
Shaft extension (DE):		Balancing:		Direction of air flow (fan):					
Fitted key		Half-key		DE → NDE		A B C D J K			
Fitted key		Half-key		NDE → DE ⁷⁾					
Fitted key		Full-key		DE → NDE					
Fitted key		Full-key		NDE → DE ⁷⁾					
Plain shaft		–		DE → NDE					
Plain shaft		–		NDE → DE ⁷⁾					
Seal:		Paint finish:							
–		None				0 2 3 5 6 8			
Flange and shaft sealing ring ⁶⁾		None							
–		Anthracite (RAL 7016), standard paint finish							
Flange and shaft sealing ring ⁶⁾		Anthracite (RAL 7016), standard paint finish							
–		Anthracite (RAL 7016), special paint finish							
Flange and shaft sealing ring ⁶⁾		Anthracite (RAL 7016), special paint finish							
Special versions:		Specify supplementary order code and plain text if applicable (see Options).						–Z	
Motor Module:		Single Motor Module						1	
		Double Motor Module						2	
								1	
								0	

1) n_2 : Max. permissible thermal speed at constant output or speed, which is at the voltage limit when $P = P_{\text{rated}}$.

2) n_{S1} : Max. permissible speed that is continuously permitted without speed duty cycles.

3) n_{max} : Maximum speed which must not be exceeded.

4) Model with brake possible if:
12th position "2" or "3",
14th position "K",
15th position "A", "B", "J" or "K",
16th position "0", "3" or "6".

5) Max. possible speed (see also selection guides):
SH 100: 12000 rpm, SH 132: 10000 rpm, SH 160: 8000 rpm,
with keyless shaft only (15th position "J" or "K" and 16th position "0",
"3" or "6").

6) Only appropriate if oil spray/mist occasionally gets onto the sealing ring. A sealing ring is not possible for type IM B3 (IM V5, IM V6), or version with increased maximum speed.

7) Preferred air-flow direction in polluted environment.

8) Speed is limited to lower values in some cases. The following restriction applies: Max. output frequency < 5 × motor rated frequency.

AC motors

Asynchronous motors

1PH7 motors

Selection and ordering data

Rated speed n_{rated} rpm	Shaft height SH	Rated power P_{rated} kW/HP	Rated torque M_{rated} Nm/lb _r -ft	Rated current I_{rated} A	Rated voltage V_{rated} V	Speed during field weakening ¹⁾ n_2 rpm	Max. permissible continuous speed ²⁾ n_{S1} rpm	Max. speed ³⁾ n_{max} rpm	1PH7 asynchronous motor Order No.
480 V 3 AC line voltage, Servo/Vector Control									
2000	100	4.7/6	22/16.2	10	459	7580	5500	9000	1PH7101-■ ■ F ■ ■ -■ ...
		7/9.4	33/24.3	13	459	4100	5500	9000	1PH7103-■ ■ F ■ ■ -■ ...
		9/12.1	43/31.7	17.5	450	7160	5500	9000	1PH7105-■ ■ F ■ ■ -■ ...
		11/14.8	53/39.1	23	433	5500	5500	9000	1PH7107-■ ■ F ■ ■ -■ ...
	132	15/20.1	72/53.1	25	459	5660	4500	8000	1PH7131-■ ■ F ■ ■ -■ ...
		20/26.8	96/70.8	34	459	5910	4500	8000	1PH7133-■ ■ F ■ ■ -■ ...
		24/32.2	115/84.8	42	459	6730	4500	8000	1PH7135-■ ■ F ■ ■ -■ ...
		28/37.6	134/98.8	55	402	4000	4500	8000	1PH7137-■ ■ F ■ ■ -■ ...
	160	37/49.6	177/130.4	70	412	4000	3700	6500	1PH7163-■ ■ F ■ ■ -■ ...
		45/60.4	215/158.5	76	459	3250	3700	6500	1PH7167-■ ■ F ■ ■ -■ ...
2650	100	8/10.7	29/21.4	16.5	440	7500	5500	9000	1PH7103-■ ■ G ■ ■ -■ ...
		13/17.4	47/34.6	24.5	459	7500	5500	9000	1PH7107-■ ■ G ■ ■ -■ ...
	132	24/32.2	87/64.1	42	450	4000	4500	8000	1PH7133-■ ■ G ■ ■ -■ ...
		30/40.2	108/79.6	52	450	4250	4500	8000	1PH7137-■ ■ G ■ ■ -■ ...
	160	40/53.6	144/106.1	76	433	3500	3700	6500	1PH7163-■ ■ G ■ ■ -■ ...
		44/6	159/117.2	77	459	3250	3700	6500	1PH7167-■ ■ G ■ ■ -■ ...
Fans:		External fan unit, heavy-gauge threaded cable entry in terminal box Without external fan unit, for pipe connection, heavy-gauge threaded cable entry in terminal box External fan unit, metric cable entry in terminal box Without external fan unit, for pipe connection, metric cable entry in terminal box							2 6 7 8
Encoder systems for motors without DRIVE-CLiQ interface:		Without encoder Absolute encoder EnDat 2048 pulses/revolution Incremental encoder HTL 1024 pulses/revolution Incremental encoder HTL 2048 pulses/revolution Incremental encoder sin/cos 1 V _{pp} with C and D tracks Incremental encoder sin/cos 1 V _{pp} without C and D tracks 2-pole resolver							A E H J M N R
Encoder systems for motors with DRIVE-CLiQ interface:		Absolute encoder EnDat 2048 pulses/revolution Incremental encoder sin/cos 1 V _{pp} with C and D tracks Incremental encoder sin/cos 1 V _{pp} without C and D tracks 2-pole resolver							F D Q P
Terminal box/cable entry (view onto DE):		Top/from right Top/from NDE Top/from left							0 2 3
Type:		IM B3 (IM V5, IM V6) IM B5 (IM V1, IM V3) available only for shaft heights 100 and 132 IM B35 (IM V15, IM V36)							0 2 3
Holding brake with emergency stop function ⁴⁾:		Without brake							0
		Brake supply voltage 230 V 1 AC, 50/60 Hz	With brake With brake (includes microswitch) With brake (includes manual release) With brake (includes manual release and microswitch)					1 2 3 4	
		Brake supply voltage 24 V DC	With brake With brake (includes microswitch) With brake (includes manual release) With brake (includes manual release and microswitch)					5 6 7 8	

Selection and ordering data

Power factor $\cos \varphi$	Magnetizing current I_{μ} A	Efficiency η_{rated}	Rated frequency f_{rated} Hz	Moment of inertia of J kgm ² /lb _f -in-s ²	Weight, approx. kg/lb	1PH7 asynchronous motor		SINAMICS S120 Motor Module Rated output current	
						Order No.	I_{rated} A	Order No.	
480 V 3 AC line voltage, Servo/Vector Control									
0.72	6.0	0.862	68.2	0.017/0.15	40/88.2	1PH7101- . . F . . . ■■■■	18	6SL3120- ■ TE21-8AA ■	
0.82	5.6	0.860	69.1	0.017/0.15	40/88.2	1PH7103- . . F . . . ■■■■	18	6SL3120- ■ TE21-8AA ■	
0.78	9.3	0.878	68.3	0.029/0.257	65/143.33	1PH7105- . . F . . . ■■■■	18	6SL3120- ■ TE21-8AA ■	
0.79	10.8	0.876	68.6	0.029/0.257	65/143.33	1PH7107- . . F . . . ■■■■	30	6SL3120- 1 TE23-0AA 1	
0.88	8.5	0.903	68.0	0.076/0.673	90/198.45	1PH7131- . . F . . . ■■■■	30	6SL3120- 1 TE23-0AA 1	
0.84	15	0.900	68.0	0.076/0.673	90/198.45	1PH7133- . . F . . . ■■■■	45	6SL3120- 1 TE24-5AA 1	
0.85	17	0.905	67.8	0.109/0.965	150/330.75	1PH7135- . . F . . . ■■■■	45	6SL3120- 1 TE24-5AA 1	
0.85	23	0.900	67.9	0.109/0.965	150/330.75	1PH7137- . . F . . . ■■■■	60	6SL3120- 1 TE26-0AA 1	
0.85	29	0.912	67.5	0.185/1.637	175/385.88	1PH7163- . . F . . . ■■■■	85	6SL3120- 1 TE28-5AA 1	
0.84	32	0.916	67.4	0.228/2.018	210/463.05	1PH7167- . . F . . . ■■■■	85	6SL3120- 1 TE28-5AA 1	
0.78	8.2	0.871	90.3	0.017/0.15	40/88.2	1PH7103- . . G . . . ■■■■	18	6SL3120- ■ TE21-8AA ■	
0.78	12	0.887	90.2	0.029/0.257	65/143.33	1PH7107- . . G . . . ■■■■	30	6SL3120- 1 TE23-0AA 1	
0.85	17	0.898	89.6	0.076/0.673	90/198.45	1PH7133- . . G . . . ■■■■	45	6SL3120- 1 TE24-5AA 1	
0.84	21	0.894	89.4	0.109/0.965	150/330.75	1PH7137- . . G . . . ■■■■	60	6SL3120- 1 TE26-0AA 1	
0.82	37	0.895	89.0	0.185/1.637	175/385.88	1PH7163- . . G . . . ■■■■	85	6SL3120- 1 TE28-5AA 1	
0.80	40	0.911	89.0	0.228/2.018	210/463.05	1PH7167- . . G . . . ■■■■	85	6SL3120- 1 TE28-5AA 1	
Output type:		Vibration severity grade:		Shaft and flange accuracy:					
Coupling/belt		R		R		B C D K L			
Coupling/belt		S		R					
Coupling/belt		SR		R					
Coupling/belt		N		N (with brake mounting)					
Increased max. speed ⁵⁾		SR		R					
Shaft extension (DE):		Balancing:		Direction of air flow (fan):		A B C D J K			
Fitted key		Half-key		DE → NDE					
Fitted key		Half-key		NDE → DE ⁷⁾					
Fitted key		Full-key		DE → NDE					
Fitted key		Full-key		NDE → DE ⁷⁾					
Plain shaft		–		DE → NDE					
Plain shaft		–		NDE → DE ⁷⁾					
Seal:		Paint finish:				0 2 3 5 6 8			
–		None							
Flange and shaft sealing ring ⁶⁾		None							
–		Anthracite (RAL 7016), standard paint finish							
Flange and shaft sealing ring ⁶⁾		Anthracite (RAL 7016), standard paint finish							
–		Anthracite (RAL 7016), special paint finish							
Flange and shaft sealing ring ⁶⁾		Anthracite (RAL 7016), special paint finish							
Special versions:		Specify supplementary order code and plain text if applicable (see Options).						–Z	
Motor Module:		Single Motor Module						1	
		Double Motor Module						2	
								1	
								0	

1) n_2 : Max. permissible thermal speed at constant output or speed, which is at the voltage limit when $P = P_{\text{rated}}$.

2) n_{S1} : Max. permissible speed that is continuously permitted without speed duty cycles.

3) n_{max} : Maximum speed which must not be exceeded.

4) Model with brake possible if:
12th position "2" or "3",
14th position "K",
15th position "A", "B", "J" or "K",
16th position "0", "3" or "6".

5) Max. possible speed (see also selection guides):
SH 100: 12000 rpm, SH 132: 10000 rpm, SH 160: 8000 rpm,
with keyless shaft only (15th position "J" or "K" and 16th position "0",
"3" or "6").

6) Only appropriate if oil spray/mist occasionally gets onto the sealing ring. A sealing ring is not possible for type IM B3 (IM V5, IM V6), or version with increased maximum speed.

7) Preferred air-flow direction in polluted environment.

AC motors

Asynchronous motors

1PH7 motors

Selection and ordering data

Rated speed n_{rated} rpm	Shaft height SH	Rated power P_{rated} kW/HP	Rated torque M_{rated} Nm/lb _r -ft	Rated current I_{rated} A	Rated voltage V_{rated} V	Speed during field weakening ¹⁾ n_2 rpm	Max. permissible continuous speed ²⁾ n_{S1} rpm	Max. speed ³⁾ n_{max} rpm	1PH7 asynchronous motor Order No.
480 V 3 AC line voltage, Servo/Vector Control									
500	180	20.5/27.5	392/288.9	51	335	3200 ¹¹⁾	3500 ⁴⁾¹¹⁾	5000 ¹¹⁾	1PH7184-■ ■ B ■ ■ -■ ...
		26.5/35.5	506/372.9	67	335	3600 ¹¹⁾	3500 ⁴⁾¹¹⁾	5000 ¹¹⁾	1PH7186-■ ■ B ■ ■ -■ ...
	225	38/51.0	725/534.3	86	335	2900 ¹¹⁾	3100 ⁴⁾¹¹⁾	4500 ¹¹⁾	1PH7224-■ ■ B ■ ■ -■ ...
		49/65.7	935/689.1	112	330	3200 ¹¹⁾	3100 ⁴⁾¹¹⁾	4500 ¹¹⁾	1PH7226-■ ■ B ■ ■ -■ ...
1350	180	60/80.5	1145/843.9	135	340	3200 ¹¹⁾	3100 ⁴⁾¹¹⁾	4500 ⁴⁾¹¹⁾	1PH7228-■ ■ B ■ ■ -■ ...
		50/67.1	355/261.6	86	450	5000	3500 ⁴⁾	5000	1PH7184-■ ■ D ■ ■ -■ ...
	225	67/89.9	475/350.1	114	460	5000	3500 ⁴⁾	5000	1PH7186-■ ■ D ■ ■ -■ ...
		92/123.4	650/479.1	156	450	2900	3100 ⁴⁾	4500	1PH7224-■ ■ D ■ ■ -■ ...
		120/160.9	847/624.2	193	460	2900	3100 ⁴⁾	4500	1PH7226-■ ■ D ■ ■ -■ ...
2000	180	147/197.1	1043/768.7	232	460	2900	3100 ⁴⁾	4500 ⁴⁾	1PH7228-■ ■ D ■ ■ -■ ...
		68/91.2	325/239.5	120	450	5000	3500 ⁴⁾	5000	1PH7184-■ ■ F ■ ■ -■ ...
	225	94/126.1	450/331.7	165	445	5000	3500 ⁴⁾	5000	1PH7186-■ ■ F ■ ■ -■ ...
		124/166.3	590/434.8	200	460	2900	3100 ⁴⁾	4500	1PH7224-■ ■ U ■ ■ -■ ...
2900	180	153/205.2	730/538	254	450	2900	3100 ⁴⁾	4500	1PH7226-■ ■ F ■ ■ -■ ...
		196/262.8	936/689.8	332	450	3000	3100 ⁴⁾	4500 ⁴⁾	1PH7228-■ ■ F ■ ■ -■ ...
	225	81/108.6	267/196.8	158	395	5000	3500 ⁴⁾	5000	1PH7184-■ ■ L ■ ■ -■ ...
		101/135.4	333/245.4	206	385	5000	3500 ⁴⁾	5000	1PH7186-■ ■ L ■ ■ -■ ...
3500	180	149/199.8	490/361.1	274	395	3500	3100 ⁴⁾	4500	1PH7224-■ ■ L ■ ■ -■ ...
		185/248.1	610/449.6	348	390	3500	3100 ⁴⁾	4500	1PH7226-■ ■ L ■ ■ -■ ...
	215/288.3	708/521.8	402	395	3500	3100 ⁴⁾	4500 ⁴⁾	1PH7228-■ ■ L ■ ■ -■ ...	
Fans:	External fan unit, heavy-gauge threaded cable entry in terminal box Without external fan unit, for pipe connection, heavy-gauge threaded cable entry in terminal box External fan unit, metric cable entry in terminal box Without external fan unit, for pipe connection, metric cable entry in terminal box								2 6 7 8
Encoder systems for motors without DRIVE-CLIQ interface:	Without encoder Absolute encoder EnDat 2048 pulses/revolution Incremental encoder HTL 1024 pulses/revolution Incremental encoder HTL 2048 pulses/revolution Incremental encoder sin/cos 1 V _{pp} with C and D tracks ¹⁰⁾ Incremental encoder sin/cos 1 V _{pp} without C and D tracks ¹⁰⁾ 2-pole resolver								A E H J M N R
Encoder systems for motors with DRIVE-CLIQ interface:	Absolute encoder EnDat 2048 pulses/revolution Incremental encoder sin/cos 1 V _{pp} with C and D tracks ¹⁰⁾ Incremental encoder sin/cos 1 V _{pp} without C and D tracks ¹⁰⁾ 2-pole resolver								F D Q P
Terminal box/cable entry (view onto DE):	Top/from right Top/from DE Top/from NDE Top/from left								0 1 2 3
Type:	IM B3 IM B3 IM B35 (only for 1PH7184 with flange A 400, 1PH7186 with flange A 450, 1PH722. with flange A 550) IM B35 (only for 1PH7184 with flange A 450) IM B35 (only for 1PH7184 with flange A 400, 1PH7186 with flange A 450, 1PH722. with flange A 550) IM B35 (only for 1PH7184 with flange A 450)								0 1 3 4 5 6
Holding brake with emergency stop function (suitable for coupling output in construction type IM B3) ⁵⁾:	Without brake With brake (includes emergency release screws and microswitch) With brake (includes manual release and microswitch)								0 2 4

Selection and ordering data

Power factor $\cos \varphi$	Magnetizing current I_{μ} A	Efficiency η_{rated}	Rated frequency f_{rated} Hz	Moment of inertia of J kgm ² / lb _f -in-s ²	Weight, approx. kg/lb	1PH7 asynchronous motor	SINAMICS S120 Motor Module Rated output current	
						Order No.	I_{rated} A	Order No.
480 V 3 AC line voltage, Servo/Vector Control								
0.83	26	0.858	17.5	0.503/4.452	370/815.85	1PH7184- . . B ■■■■	60	6SL3120-1 TE26-0AA1
0.79	39.5	0.870	17.3	0.666/5.895	440/970.2	1PH7186- . . B ■■■■	85	6SL3120-1 TE28-5AA1
0.85	37.5	0.888	17.3	1.479/13.09	630/1389.2	1PH7224- . . B ■■■■	85 ⁹⁾	6SL3120-1 TE28-5AA1
0.85	50	0.900	17.3	1.930/17.082	750/1653.8	1PH7226- . . B ■■■■	132	6SL3120-1 TE31-3AA0
0.84	61.5	0.907	17.2	2.326/20.587	860/1896.3	1PH7228- . . B ■■■■	132 ⁹⁾	6SL3120-1 TE31-3AA0
0.81	42	0.928	45.8	0.503/4.452	370/815.85	1PH7184- . . D ■■■■	85 ⁹⁾	6SL3120-1 TE28-5AA1
0.79	59.5	0.930	45.7	0.666/5.895	440/970.2	1PH7186- . . D ■■■■	132	6SL3120-1 TE31-3AA0
0.80	78.5	0.942	45.6	1.479/13.09	630/1389.2	1PH7224- . . D ■■■■	200	6SL3120-1 TE32-0AA0
0.82	88.5	0.945	45.6	1.930/17.082	750/1653.8	1PH7226- . . D ■■■■	200	6SL3120-1 TE32-0AA0
0.84	99.5	0.947	45.6	2.326/20.587	860/1896.3	1PH7228- . . D ■■■■	260	6SL3320-1 TE32-6AA0
0.78	66	0.935	67.3	0.503/4.452	370/815.85	1PH7184- . . F ■■■■	132	6SL3120-1 TE31-3AA0
0.78	87	0.941	67.3	0.666/5.895	440/970.2	1PH7186- . . F ■■■■	200	6SL3120-1 TE32-0AA0
0.82	91	0.944	67.2	1.479/13.09	630/1389.2	1PH7224- . . U ■■■■	200	6SL3120-1 TE32-0AA0
0.82	119	0.948	67.2	1.930/17.082	750/1653.8	1PH7226- . . F ■■■■	260	6SL3320-1 TE32-6AA0
0.79	168	0.950	67.1	2.326/20.587	860/1896.3	1PH7228- . . F ■■■■	380	6SL3320-1 TE33-8AA0
0.80	77	0.934	97.4	0.503/4.452	370/815.85	1PH7184- . . L ■■■■	200	6SL3120-1 TE32-0AA0
0.78	107	0.936	97.3	0.666/5.895	440/970.2	1PH7186- . . L ■■■■	210	6SL3320-1 TE32-1AA0
0.84	115	0.946	97.3	1.479/13.09	630/1389.2	1PH7224- . . L ■■■■	310	6SL3320-1 TE33-1AA0
0.83	154	0.946	97.2	1.930/17.082	750/1653.8	1PH7226- . . L ■■■■	380	6SL3320-1 TE33-8AA0
0.82	188	0.954	97.2	2.326/20.587	860/1896.3	1PH7228- . . L ■■■■	490	6SL3320-1 TE35-0AA0
Output type:	Vibration severity grade:	Shaft and flange accuracy:						
Coupling	R	N						
Coupling	R	R						
Coupling	S	R						
Coupling	SR	R						
Belt	R	N						
Belt	R	R						
Incr. cantilever forces	R	N						
Incr. cantilever forces	R	R						
Increased max. speed ⁶⁾	S	R						
Shaft extension (DE):	Balancing:	Direction of air flow (fan):						
Fitted key	Half-key	DE → NDE						
Fitted key	Half-key	NDE → DE ⁸⁾						
Fitted key	Full-key	DE → NDE						
Fitted key	Full-key	NDE → DE ⁸⁾						
Plain shaft	–	DE → NDE						
Plain shaft	–	NDE → DE ⁸⁾						
Seal:	Paint finish:							
–	Primed							
Flange and shaft sealing ring ⁷⁾	Primed							
–	Anthracite (RAL 7016), standard paint finish							
Flange and shaft sealing ring ⁷⁾	Anthracite (RAL 7016), standard paint finish							
–	Anthracite (RAL 7016), special paint finish							
Flange and shaft sealing ring ⁷⁾	Anthracite (RAL 7016), special paint finish							
Special versions:	Specify supplementary order code and plain text if applicable (see Options).							

- n_2 : Max. permissible thermal speed at constant output or speed, which is at the voltage limit when $P = P_{\text{rated}}$.
- n_{S1} : Max. permissible speed that is continuously permitted without speed duty cycles.
- n_{max} : Maximum speed which must not be exceeded.
- Speed is reduced with increased cantilever forces, see selection guides.
- Model with brake: 12th position "0", 14th position "A", 15th position "A" or "B", 16th position "0", "3" or "6".
- For shaft height 180 $n_{\text{max}} = 7000$ rpm, 1PH7 224 $n_{\text{max}} = 5500$ rpm, only coupling output possible and 16th position "0", "3" or "6".

- Only appropriate if oil spray/mist occasionally gets onto the sealing ring. A sealing ring is not possible for type IM B3 (IM V5, IM V6), version with increased maximum speed, version for belt output or increased cantilever forces.
- Preferred air-flow direction in polluted environment.
- The rated output current of the Motor Module is lower than the motor rated current.
- When ordering option **L27**, please also select option **M84** (insulated version of encoder).
- Speed is limited to lower values in some cases. The following restriction applies: Max. output frequency < 5 × motor rated frequency.

AC motors

Asynchronous motors

1PH7 motors

Selection and ordering data

Rated speed	Shaft height SH	Rated power	Rated torque	Rated current	Rated voltage	Speed during field weakening ¹⁾	Max. permissible continuous speed ²⁾	Max. speed ³⁾	1PH7 asynchronous motor
n_{rated} rpm		P_{rated} kW/HP	M_{rated} Nm/lb _f -ft	I_{rated} A	V_{rated} V	n_2 rpm	n_{S1} rpm	n_{max} rpm	Order No.
480 V 3 AC line voltage, Servo/Vector Control									
600	280	95/127.4	1519/1119.5	144	480	2200	2200	3300 ⁷⁾	1PH7284-■ ■ B ■ ■ -0 ...
		120/160.9	1916/1412.1	180	480	2200	2200	3300 ⁷⁾	1PH7286-■ ■ B ■ ■ -0 ...
		155/207.9	2467/1818.2	233	480	2200	2200	3300 ⁷⁾	1PH7288-■ ■ B ■ ■ -0 ...
1000	280	150/201.2	1433/1056.1	220	480	2200	2200	3300	1PH7284-■ ■ C ■ ■ -0 ...
		185/248.1	1767/1302.3	285	480	2200	2200	3300	1PH7286-■ ■ C ■ ■ -0 ...
		230/308.4	2197/1619.2	365	460	2200	2200	3300	1PH7288-■ ■ C ■ ■ -0 ...
1350	280	200/268.2	1416/1043.6	314	470	2200	2200	3300	1PH7284-■ ■ D ■ ■ -0 ...
		245/328.6	1733/1277.2	414	445	2200	2200	3300	1PH7286-■ ■ D ■ ■ -0 ...
		305/409.0	2158/1590.4	497	450	2200	2200	3300	1PH7288-■ ■ D ■ ■ -0 ...
2000	280	255/342.0	1218/897.7	393	455	2200	2200	3300	1PH7284-■ ■ F ■ ■ -0 ...
		310/415.7	1481/1091.5	466	455	2200	2200	3300	1PH7286-■ ■ F ■ ■ -0 ...
		385/516.3	1838/1354.6	586	455	2200	2200	3300	1PH7288-■ ■ F ■ ■ -0 ...
Fans ⁴⁾:	External fan unit, NDE at top, air-flow direction NDE to DE External fan unit, NDE on right, air-flow direction NDE to DE External fan unit, NDE on left, air-flow direction NDE to DE External fan unit, DE at top, air-flow direction DE to NDE External fan unit, DE on right, air-flow direction DE to NDE External fan unit, DE on left, air-flow direction DE to NDE Without external fan unit, for single pipe connection at NDE on right								0 1 2 3 4 5 6
Encoder systems for motors without DRIVE-CLiQ interface:	Without encoder Absolute encoder EnDat 2048 pulses/revolution Incremental encoder HTL 1024 pulses/revolution Incremental encoder HTL 2048 pulses/revolution Incremental encoder sin/cos 1 V_{pp} with C and D tracks ⁶⁾ Incremental encoder sin/cos 1 V_{pp} without C and D tracks ⁶⁾ 2-pole resolver								A E H J M N R
Encoder systems for motors with DRIVE-CLiQ interface:	Absolute encoder EnDat 2048 pulses/revolution Incremental encoder sin/cos 1 V_{pp} with C and D tracks ⁶⁾ Incremental encoder sin/cos 1 V_{pp} without C and D tracks ⁶⁾ 2-pole resolver								F D Q P
Terminal box/cable entry (view onto DE) ⁴⁾:	NDE right/from below/encoder connector DE NDE left/from below/encoder connector DE NDE top/from right/encoder connector DE DE top/from right/encoder connector NDE								0 1 2 5
Type ⁴⁾:	IM B3 IM V5 (can be subsequently modified to IM V6) IM B35 (with flange A660) IM V15 (with flange A 660; can be subsequently modified to IM V36)								0 1 3 5



Selection and ordering data

Power factor $\cos \varphi$	Magnetizing current I_{μ} A	Efficiency η_{rated}	Rated frequency f_{rated} Hz	Moment of inertia of J kgm ² /lb _r -in-s ²	Weight, approx. kg/lb	1PH7 asynchronous motor	SINAMICS S120 Motor Module Rated output current	
						Order No.	I_{rated} A	Order No.
480 V 3 AC line voltage, Servo/Vector Control								
0.86	61	0.932	20.3	4.2/37.173	1300/2866.5	1PH7284- . . B . . -0 ■■■	200	6SL3120-1TE32-0AA0
0.86	80	0.939	20.3	5.2/46.02	1500/3307.5	1PH7286- . . B . . -0 ■■■	200	6SL3120-1TE32-0AA0
0.86	102	0.941	20.3	6.3/55.76	1700/3748.5	1PH7288- . . B . . -0 ■■■	260	6SL3320-1TE32-6AA0
0.86	90	0.950	34	4.2/37.173	1300/2866.5	1PH7284- . . C . . -0 ■■■	260	6SL3320-1TE32-6AA0
0.84	135	0.954	34	5.2/46.02	1500/3307.5	1PH7286- . . C . . -0 ■■■	310	6SL3320-1TE33-1AA0
0.84	170	0.956	34	6.3/55.76	1700/3748.5	1PH7288- . . C . . -0 ■■■	380	6SL3320-1TE33-8AA0
0.82	159	0.958	45.3	4.2/37.173	1300/2866.5	1PH7284- . . D . . -0 ■■■	310 ⁵⁾	6SL3320-1TE33-1AA0
0.80	217	0.960	45.3	5.2/46.02	1500/3307.5	1PH7286- . . D . . -0 ■■■	490	6SL3320-1TE35-0AA0
0.82	250	0.962	45.3	6.3/55.76	1700/3748.5	1PH7288- . . D . . -0 ■■■	490 ⁵⁾	6SL3320-1TE35-0AA0
0.86	162	0.962	67	4.2/37.173	1300/2866.5	1PH7284- . . F . . -0 ■■■	490	6SL3320-1TE35-0AA0
0.87	182	0.964	67	5.2/46.02	1500/3307.5	1PH7286- . . F . . -0 ■■■	490	6SL3320-1TE35-0AA0
0.87	232	0.965	67	6.3/55.76	1700/3748.5	1PH7288- . . F . . -0 ■■■	605	6SL3320-1TE36-1AA0
Output type⁴⁾:		Vibration severity grade:		Shaft and flange accuracy:				
Coupling		N		N		A		
Coupling		R		R		B		
Belt/increased cantilever forces		N		N		E		
Belt/increased cantilever forces		R		R		F		
Shaft extension (DE):		Balancing:				A		
Fitted key		Half-key				C		
Fitted key		Full-key				J		
Plain shaft		-						
Paint finish:						0		
Primed						3		
Anthracite (RAL 7016), standard paint finish						6		
Anthracite (RAL 7016), special paint finish								
Special versions: Specify supplementary order code and plain text if applicable (see Options).						-Z		

1) n_2 : Max. permissible thermal speed at constant output or speed, which is at the voltage limit when $P = P_{\text{rated}}$.

2) n_{S1} : Max. permissible speed that is continuously permitted without speed duty cycles.

3) n_{max} : Maximum speed which must not be exceeded.

4) See Table "Permissible combinations of mechanical designs".

5) The rated output current of the Motor Module is lower than the motor rated current.

6) Only in conjunction with option **M84** (insulated version of encoder).

7) Speed is limited to lower values in some cases. The following restriction applies: Max. output frequency < 5 × motor rated frequency.

AC motors

Asynchronous motors

1PH7 motors

Selection and ordering data

Rated speed n_{rated} rpm	Shaft height SH	Rated power P_{rated} kW/HP	Rated torque M_{rated} Nm/lb _r -ft	Rated current I_{rated} A	Rated voltage V_{rated} V	Speed during field weakening ¹⁾ n_2 rpm	Max. permissible continuous speed ²⁾ n_{S1} rpm	Max. speed ³⁾ n_{max} rpm	Asynchronous motor 1PH7 Order No.
690 V 3 AC line voltage, Servo/Vector Control									
500	280	77/103.3	1471/1084.1	80	690	1700	2200	3300 ⁷⁾	1PH7284-■ ■ B ■ ■ -0 ...
		96/128.7	1834/1351.7	101	690	1800	2200	3300 ⁷⁾	1PH7286-■ ■ B ■ ■ -0 ...
		125/167.6	2388/1760	130	690	1900	2200	3300 ⁷⁾	1PH7288-■ ■ B ■ ■ -0 ...
800	280	115/154.2	1373/1011.9	120	690	2200	2200	3300	1PH7284-■ ■ C ■ ■ -0 ...
		145/194.5	1731/1275.7	160	665	2200	2200	3300	1PH7286-■ ■ C ■ ■ -0 ...
		185/248.1	2208/1627.3	210	640	2200	2200	3300	1PH7288-■ ■ C ■ ■ -0 ...
1150	280	164/219.9	1362/1003.8	176	690	2200	2200	3300	1PH7284-■ ■ D ■ ■ -0 ...
		203/272.2	1686/1242.6	233	655	2200	2200	3300	1PH7286-■ ■ D ■ ■ -0 ...
		251/336.6	2084/1535.9	280	665	2200	2200	3300	1PH7288-■ ■ D ■ ■ -0 ...
1750	280	217/291.0	1184/872.6	221	690	2200	2200	3300	1PH7284-■ ■ F ■ ■ -0 ...
		261/350.0	1424/1049.5	262	690	2200	2200	3300	1PH7286-■ ■ F ■ ■ -0 ...
		329/441.2	1795/1322.9	330	690	2200	2200	3300	1PH7288-■ ■ F ■ ■ -0 ...
Fans ⁴⁾:	External fan unit, NDE at top, air-flow direction NDE to DE External fan unit, NDE on right, air-flow direction NDE to DE External fan unit, NDE on left, air-flow direction NDE to DE External fan unit, DE at top, air-flow direction DE to NDE External fan unit, DE on right, air-flow direction DE to NDE External fan unit, DE on left, air-flow direction DE to NDE Without external fan unit, for single pipe connection at NDE on right								0 1 2 3 4 5 6
Encoder systems for motors without DRIVE-CLiQ interface:	Without encoder Absolute encoder EnDat 2048 pulses/revolution Incremental encoder HTL 1024 pulses/revolution Incremental encoder HTL 2048 pulses/revolution Incremental encoder sin/cos 1 V _{pp} with C and D tracks ⁶⁾ Incremental encoder sin/cos 1 V _{pp} without C and D tracks ⁶⁾ 2-pole resolver								A E H J M N R
Encoder systems for motors with DRIVE-CLiQ interface:	Absolute encoder EnDat 2048 pulses/revolution Incremental encoder sin/cos 1 V _{pp} with C and D tracks ⁶⁾ Incremental encoder sin/cos 1 V _{pp} without C and D tracks ⁶⁾ 2-pole resolver								F D Q P
Terminal box/cable entry (view onto DE) ⁴⁾:	NDE on right/from below/encoder connector DE NDE on left/from below/encoder connector DE NDE at top/from right/encoder connector DE DE at top/from right/encoder connector NDE								0 1 2 5
Type ⁴⁾:	IM B3 IM V5 (can be subsequently modified to IM V6) IM B35 (with flange A660) IM V15 (with flange A 660; can be subsequently modified to IM V36)								0 1 3 5

Selection and ordering data

Power factor $\cos \varphi$	Magnetizing current I_{μ} A	Efficiency η_{rated}	Rated frequency f_{rated} Hz	Moment of inertia of J kgm ² / lb _r -in ²	Weight, approx. kg/lb	1PH7 asynchronous motor	SINAMICS S120 Motor Module Rated output current	
						Order No.	I_{rated} A	Order No.
690 V 3 AC line voltage, Servo/Vector Control								
0.87	34	0.923	17	4.2/37.173	1300/2866.5	1PH7284- . . B . . -0 ■■■	85	6SL3320-1 TH28-5AA0
0.86	45	0.927	17	5.2/46.02	1500/3307.5	1PH7286- . . B . . -0 ■■■	100 ⁵⁾	6SL3320-1 TH31-0AA0
0.86	57	0.930	17	6.3/55.76	1700/3748.5	1PH7288- . . B . . -0 ■■■	150	6SL3320-1 TH31-5AA0
0.85	55	0.943	27	4.2/37.173	1300/2866.5	1PH7284- . . C . . -0 ■■■	120	6SL3320-1 TH31-2AA0
0.84	80	0.947	27	5.2/46.02	1500/3307.5	1PH7286- . . C . . -0 ■■■	175	6SL3320-1 TH31-8AA0
0.84	100	0.950	27	6.3/55.76	1700/3748.5	1PH7288- . . C . . -0 ■■■	215	6SL3320-1 TH32-2AA0
0.81	91	0.955	38.6	4.2/37.173	1300/2866.5	1PH7284- . . D . . -0 ■■■	175 ⁵⁾	6SL3320-1 TH31-8AA0
0.80	125	0.957	38.6	5.2/46.02	1500/3307.5	1PH7286- . . D . . -0 ■■■	260	6SL3320-1 TH32-6AA0
0.81	145	0.959	38.6	6.3/55.76	1700/3748.5	1PH7288- . . D . . -0 ■■■	330	6SL3320-1 TH33-3AA0
0.86	94	0.961	58.7	4.2/37.173	1300/2866.5	1PH7284- . . F . . -0 ■■■	260	6SL3320-1 TH32-6AA0
0.87	105	0.963	58.7	5.2/46.02	1500/3307.5	1PH7286- . . F . . -0 ■■■	260 ⁵⁾	6SL3320-1 TH32-6AA0
0.86	134	0.964	58.7	6.3/55.76	1700/3748.5	1PH7288- . . F . . -0 ■■■	330	6SL3320-1 TH33-3AA0
Output type⁴⁾:		Vibration severity grade:		Shaft and flange accuracy:				
Coupling		N		N		A B E F		
Coupling		R		R				
Belt/incr. cantilever forces		N		N				
Belt/incr. cantilever forces		R		R				
Shaft extension:		Balancing:				A C J		
Fitted key		Half-key						
Fitted key		Full-key						
Plain shaft		-						
Paint finish:						0 3 6		
Primed								
Anthracite (RAL 7016), standard paint finish								
Anthracite (RAL 7016), special paint finish								
Special versions:		Specify supplementary order code and plain text if applicable (see Options).				-Z		
		C30 absolutely essential						

1) n_2 : Max. permissible thermal speed at constant output or speed, which is at the voltage limit when $P = P_{\text{rated}}$.

2) n_{S1} : Max. permissible speed that is continuously permitted without speed duty cycles.

3) n_{max} : Maximum speed which must not be exceeded.

4) See Table "Permissible combinations of mechanical designs".

5) The rated output current is lower than the motor rated current.

6) Only in conjunction with option **M84** (insulated version of encoder).

7) Speed is limited to lower values in some cases. The following restriction applies: Max. output frequency < 5 × motor rated frequency.

AC motors

Asynchronous motors

Permissible combinations of mechanical designs for 1PH7 motors, shaft height 280

Selection and ordering data

Permissible combinations of mechanical designs

1PH7 28 . motors
Shaft height 280

Position in order No. 8. 9. 10. 11. 12. 13. 14. 15. 16.
1PH728 . - ■ . . . ■ - . . . ■ . . .

Permissible combinations of mechanical designs

External fan unit
8th position in order no.
1PH728 . - ■

Order No. supplement

0	1	2	3	4	5	6
NDE at top NDE → DE	NDE on right NDE → DE	NDE on left NDE → DE	DE at top DE → NDE	DE on right DE → NDE	DE on left DE → NDE	Single pipe connection NDE on right (can be modified subsequently to NDE left)

1PH728 0 - Type of construction IM B3

1PH728 1 - Type of construction IM V5
(can be modified subsequently to IM V6)

1PH728 3 - Type of construction IM B35

1PH728 5 - Type construction IM V15
(can be modified subsequently to IM V 36)

Order codes for options

R1Y Standard finish RAL ...						
R2Y Special finish RAL ...						
G14 With air filter						
K08 Encoder connector mounted opposite						
K55 Cable entry plate, terminal box, customer-specific ¹⁾						
K83 Terminal box rotated through +90 degrees						
K84 Terminal box rotated through -90 degrees						
K85 Terminal box rotated through 180 degrees						
K16 Second standard shaft extension (possible only for encoderless systems)						
K31 Second rating plate						
K45 230 V anti-condensation heating						
C30 690 V version						
Y55 Non-standard shaft extension DE						
Y80 Different rating plate data ¹⁾						
Y82 Extra rating plate with customer data ¹⁾						
M83 Additional thread for a setting screw on motor feet						

Standard design
Released supplementary versions

¹⁾ Plain text is necessary

Permissible combinations of mechanical designs
for 1PH7 motors, shaft height 280

Terminal box 11th position in order no. 1PH728 ■				Construction type 12th position in order no. 1PH728 ■				Drive type 14th position in order no. 1PH728 ■			
Order No. supplement				Order No. supplement				Order No. supplement			
0	1	2	5	0	1	3	5	A	B	E	F
NDE on right Cable entry at bottom, encoder connector DE	NDE on left Cable entry at bottom, encoder connector DE	NDE at top Cable entry on right, encoder connector DE	DE at top Cable entry on right, encoder connector NDE	Construc- tion type IM B3	Construc- tion type IM V5 (IM V6)	Construc- tion type IM B35	Construc- tion type IM V15 (IM V36)	Coupling N/N	Coupling R/R	Belt/ increased cantilever forces N/N	Belt/ increased cantilever forces R/R

AC motors

Asynchronous motors

1PL6 motors

Overview



1PL6 AC motors, shaft heights 180 to 225



1PL6 AC motors, shaft height 280

The 1PL6 AC motors are compact, force-ventilated or enclosed-ventilated squirrel-cage asynchronous motors with degree of protection IP23. The motors are ventilated using a built-on separately-driven fan unit.

The motor can be ordered either with the air flow from the motor drive end (DE) to the motor non-drive end (NDE) - or vice versa.

Depending on the control requirements, the appropriate encoder systems are available for the motors. These encoders are used to sense the motor speed and indirect position.

The motors comply with DIN standards and have degree of protection IP23 in accordance with EN 60034-5 (or IEC 60034-5). With this degree of protection, the motors are not suitable for operation in corrosive atmospheres or for installation outdoors.

Benefits

- Extremely high power density with compact dimensions (50 to 60% higher output as compared to 1PH7 in degree of protection IP55)
- Speed down to zero without reducing the torque
- Robustness
- Essentially maintenance-free
- High cantilever force loading
- High rotational accuracy, even at the lowest speeds
- Integrated encoder system to sense the motor speed, connected using a connector or DRIVE-CLiQ
- Terminal box to connect up power cables
- Motor temperature monitoring with KTY 84
- Variable versions of cooling system
- Basic external cooling using a pipe connection
- Optional bearing designs with re-lubrication device and insulated bearings (NDE)

Applications

Installation in dry inside areas (no corrosive atmosphere).

Crane systems:

- Hoisting and closing gears for cranes

Printing industry:

- Main drives for printing machines

Manufacture of rubber, plastic and wire:

- Drives for extruders, calenders, rubber injection machines, foil machines, fleece plants
- Wire-drawing machines, cable-stranding machines, etc.

General applications such as coiler and winder drives

Technical data

Insulation of the stator winding in accordance with EN 60034-1 (IEC 60034-1)	Thermal Class F for a coolant temperature of up to +40 °C (+104 °F)
Fan supply voltage (see selection guides for data)	400 V 3 AC 50 Hz/60 Hz 480 V 3 AC 60 Hz
Type in accordance with EN 60034-7 (IEC 60034-7)	IM B3
Degree of protection in accordance with EN 60034-5 (IEC 60034-5)	IP23
Cooling in accordance with EN 60034-6 (IEC 60034-6)	SH 180 and 225: Forced ventilation and enclosed ventilation Fan mounted axially at NDE, air-flow direction from NDE to DE SH 225 and 280 Forced ventilation, fan is mounted radially at NDE, air-flow direction from NDE to DE
Temperature monitoring	KTY 84 temperature sensor in the stator winding SH 280: Additional KTY 84 as reserve
Paint finish	Primed, Standard paint finish, anthracite RAL 7016
Shaft extension on the drive end in accordance with DIN 748-3 (IEC 60072-1)	with fitted key, half-key balancing
Shaft and flange accuracy in accordance with DIN 42955 (IEC 60072-1)	Tolerance N (normal)
Vibration severity grade in accordance with EN 60034-14 (IEC 60034-14)	Shaft heights 180 and 225: Grade R (reduced) SH 280: Grade N (normal)
Sound pressure level in accordance with DIN EN ISO 1680 tolerance +3 dB	Sound pressure level as a function of air-flow direction see selection guides
Bearing versions and maximum speeds	see selection guides
Encoder system, built-in for motors with/without DRIVE-CLiQ interface	<ul style="list-style-type: none"> • Incremental encoder HTL 1024 p./r. • Incremental encoder sin/cos 1 V_{pp} 2048 pulses/revolution • Absolute encoder EnDat 2048 p./r. • 2-pole resolver
Connection	Connector for signals (mating connector not supplied) Terminal box for power SH 180 and 225: Terminal box at top SH 280: Terminal box NDE right
Options	Refer to Options and Selection and ordering data

Options

Order code	Option description	For use with 1PL6 asynchronous motors with shaft height		
		SH 180 SH 225 Axial ventilation	SH 225 Radial ventilation	SH 280
R1Y	Normal paint finish in another color, RAL ... (plain text description required)	■	■	■
R2Y	Special paint finish in another color, RAL ... (plain text description required)	■	■	■
C30	Winding version 690 V	–	–	■
G14	Fan unit with air filter	●	■	■
G00	External fan unit, radial NDE left	–	■	pages 3/156 and 3/157
G02	External fan unit, radial NDE right	–	■	pages 3/156 and 3/157
G04	External fan unit, radial NDE top	–	■	pages 3/156 and 3/157
G80	POG10 pulse encoder, mounting prepared	–	■	■
K08	Encoder connector mounted opposite	–	■	■
K09	Terminal box arrangement, NDE right	–	■	pages 3/156 and 3/157
K10	Terminal box arrangement, NDE left	–	■	pages 3/156 and 3/157
K11	Terminal box arrangement, NDE top	–	■	pages 3/156 and 3/157
K16	Second standard shaft extension (possible only for encoderless systems)	–	●	■
K31	2nd rating plate supplied separately in terminal box	■	■	■
K40	Re-lubrication devices, DE and NDE	■	■	✓
K45	230 V standstill heating	–	●	■
K55	Cable entry plate, terminal box, customer-specific (plain text is required)	■	■	■
K83	Rotation of terminal box through +90 °	–	■	■
K84	Rotation of terminal box through –90 °	–	■	■
K85	Rotation of terminal box through +180 °	–	■	■
L27	NDE bearing, insulated version	■	■	✓
M83	Additional thread for a setting screw on motor feet	–	–	■
Y55	Non-standard shaft extension DE	●	●	●
Y80	Different rating plate data (plain text is required)	●	●	●
Y82	Extra rating plate with customer data	●	●	●

■ Option available – Not available
● On request ✓ Standard

Characteristics

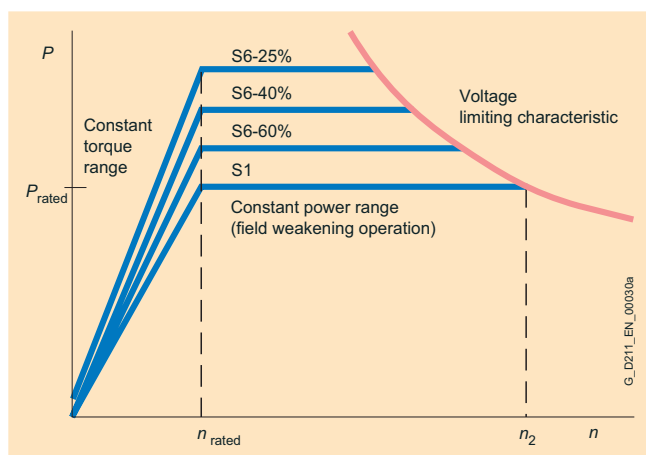

Power/speed characteristic

AC motors

Asynchronous motors

1PL6 motors

Selection and ordering data

Rated speed n_{rated} rpm	Shaft height SH	Rated power P_{rated} kW/HP	Rated torque M_{rated} Nm/lb _f -ft	Rated current I_{rated} A	Rated voltage V_{rated} V	Speed during field weakening ¹⁾ n_2 rpm	Max. permissible continuous speed ²⁾ n_{S1} rpm	Max. speed ³⁾ n_{max} rpm	1PL6 asynchronous motor Order No.
400 V 3 AC line voltage, Servo Control									
400	180	20.5/27.5	489/360.4	58	290	1500	3500 ⁴⁾⁷⁾	5000 ⁷⁾	1PL6184-■ ■ B ■ ■ - 0 ...
		30.5/40.9	728/536.5	87	290	1600	3500 ⁴⁾⁷⁾	5000 ⁷⁾	1PL6186-■ ■ B ■ ■ - 0 ...
	225	40/53.6	955/703.8	105	296	1400	3100 ⁴⁾⁷⁾	4500 ⁷⁾	1PL6224-■ ■ B ■ ■ - 0 ...
		57/76.4	1361/1003.1	145	305	1400	3100 ⁴⁾⁷⁾	4500 ⁷⁾	1PL6226-■ ■ B ■ ■ - 0 ...
		72/96.6	1719/1266.9	181	305	1300	3100 ⁴⁾⁷⁾	4500 ⁴⁾⁷⁾	1PL6228-■ ■ B ■ ■ - 0 ...
1000	180	57/76.4	544/400.9	122	345	2100	3500 ⁴⁾	5000	1PL6184-■ ■ D ■ ■ - 0 ...
		74/99.2	707/521.1	157	345	2400	3500 ⁴⁾	5000	1PL6186-■ ■ D ■ ■ - 0 ...
	225	105/140.8	1003/739.2	220	345	2500	3100 ⁴⁾	4500	1PL6224-■ ■ D ■ ■ - 0 ...
		135/181.0	1289/950	278	345	2200	3100 ⁴⁾	4500	1PL6226-■ ■ D ■ ■ - 0 ...
		165/221.3	1576/1161.5	331	348	2200	3100 ⁴⁾	4500 ⁴⁾	1PL6228-■ ■ D ■ ■ - 0 ...
1500	180	76/101.9	484/356.7	165	345	4000	3500 ⁴⁾	5000	1PL6184-■ ■ F ■ ■ - 0 ...
		108/144.8	688/507.1	233	340	4000	3500 ⁴⁾	5000	1PL6186-■ ■ F ■ ■ - 0 ...
	225	142/190.4	904/666.2	292	345	2900	3100 ⁴⁾	4500	1PL6224-■ ■ F ■ ■ - 0 ...
		175/234.7	1114/821	356	345	2900	3100 ⁴⁾	4500	1PL6226-■ ■ F ■ ■ - 0 ...
		230/308.4	1465/1079.7	468	345	2900	3100 ⁴⁾	4500 ⁴⁾	1PL6228-■ ■ F ■ ■ - 0 ...
2500	180	100/134.1	382/281.5	208	345	5000	3500 ⁴⁾	5000	1PL6184-■ ■ L ■ ■ - 0 ...
		130/174.3	497/366.3	275	340	5000	3500 ⁴⁾	5000	1PL6186-■ ■ L ■ ■ - 0 ...
	225	178/238.7	680/501.2	358	345	3500	3100 ⁴⁾	4500	1PL6224-■ ■ L ■ ■ - 0 ...
		235/315.1	698/514.4	476	340	3500	3100 ⁴⁾	4500	1PL6226-■ ■ L ■ ■ - 0 ...
		265/355.4	1013/746.6	535	345	3500	3100 ⁴⁾	4500 ⁴⁾	1PL6228-■ ■ L ■ ■ - 0 ...
Fans:	External fan unit, heavy-gauge threaded cable entry in terminal box Without external fan unit, for pipe connection, heavy-gauge threaded cable entry in terminal box External fan unit, metric cable entry in terminal box Without external fan unit, for pipe connection, metric cable entry in terminal box								4 6 7 8
Encoder systems for motors without DRIVE-CLiQ interface:	Without encoder Absolute encoder EnDat 2048 pulses/revolution Incremental encoder HTL 1024 pulses/revolution Incremental encoder HTL 2048 pulses/revolution Incremental encoder sin/cos 1 V_{pp} with C and D tracks ⁷⁾ Incremental encoder sin/cos 1 V_{pp} without C and D tracks ⁷⁾ 2-pole resolver								A E H J M N R
Encoder systems for motors with DRIVE-CLiQ interface:	Absolute encoder EnDat 2048 pulses/revolution Incremental encoder sin/cos 1 V_{pp} with C and D tracks ⁷⁾ Incremental encoder sin/cos 1 V_{pp} without C and D tracks ⁷⁾ 2-pole resolver								F D Q P
Terminal box/cable entry (view onto DE):	Top/from right Top/from DE Top/from NDE Top/from left Radial ventilation for SH 225 ⁸⁾								0 1 2 3 5
Type:	IM B3 IM B3 IM B35 (SH 180: with flange A 450, SH 225: with flange A 550) IM B35 (SH 180: with flange A 450, SH 225: with flange A 550)								0 1 3 5
	Hoisting system for different construction types (IM B6, IM B7, IM B8, IM V5, IM V6)								
	Hoisting system for different construction types (IM V15, IM V36)								

Selection and ordering data

Power factor $\cos \varphi$	Magnetizing current I_{μ} A	Efficiency η_{rated}	Rated frequency f_{rated} Hz	Moment of inertia of J kgm ² / lb _f -in ²	Weight, approx. kg/lb	1PL6 asynchronous motor	SINAMICS S120 Motor Module Rated output current	
						Order No.	I_{rated} A	Order No.
400 V 3 AC line voltage, Servo Control								
0.84	33.4	0.820	14.2	0.503/4.452	370/815.85	1PL6184- . . B . . - 0 ■■■■	60	6SL3120-1 TE26-0AA1
0.84	48.6	0.828	14.1	0.666/5.895	440/970.2	1PL6186- . . B . . - 0 ■■■■	85 ⁹⁾	6SL3120-1 TE28-5AA1
0.86	45.8	0.864	14	1.479/13.09	630/1389.2	1PL6224- . . B . . - 0 ■■■■	132	6SL3120-1 TE31-3AA0
0.85	67	0.868	14	1.930/17.082	750/1653.8	1PL6226- . . B . . - 0 ■■■■	200	6SL3120-1 TE32-0AA0
0.86	77	0.871	14.1	2.326/20.587	860/1896.3	1PL6228- . . B . . - 0 ■■■■	200	6SL3120-1 TE32-0AA0
0.87	45	0.897	34.4	0.503/4.452	370/815.85	1PL6184- . . D . . - 0 ■■■■	132	6SL3120-1 TE31-3AA0
0.86	61	0.907	34.3	0.666/5.895	440/970.2	1PL6186- . . D . . - 0 ■■■■	200	6SL3120-1 TE32-0AA0
0.86	86	0.927	34.5	1.479/13.09	630/1389.2	1PL6224- . . D . . - 0 ■■■■	210 ⁹⁾	6SL3320-1 TE32-1AA0
0.88	90	0.927	31.1	1.930/17.082	750/1653.8	1PL6226- . . D . . - 0 ■■■■	310	6SL3320-1 TE33-1AA0
0.89	103	0.928	34.2	2.326/20.587	860/1896.3	1PL6228- . . D . . - 0 ■■■■	380	6SL3320-1 TE33-8AA0
0.84	70	0.924	50.9	0.503/4.452	370/815.85	1PL6184- . . F . . - 0 ■■■■	200	6SL3120-1 TE32-0AA0
0.85	91	0.930	50.9	0.666/5.895	460/	1PL6186- . . F . . - 0 ■■■■	260	6SL3320-1 TE32-1AA0
0.87	91	0.940	50.9	1.479/13.09	640/	1PL6224- . . F . . - 0 ■■■■	310	6SL3320-1 TE33-1AA0
0.87	125	0.944	50.7	1.930/17.082	760/	1PL6226- . . F . . - 0 ■■■■	380	6SL3320-1 TE33-8AA0
0.86	177	0.947	50.7	2.326/20.587	870/	1PL6228- . . F . . - 0 ■■■■	490	6SL3320-1 TE35-0AA0
0.86	80	0.936	84.2	0.503/4.452	390/	1PL6184- . . L . . - 0 ■■■■	210	6SL3320-1 TE32-1AA0
0.85	113	0.943	84.1	0.666/5.895	470/	1PL6186- . . L . . - 0 ■■■■	310	6SL3320-1 TE33-1AA0
0.87	119	0.950	84.1	1.479/13.09	640/	1PL6224- . . L . . - 0 ■■■■	380	6SL3320-1 TE33-8AA0
0.88	157	0.953	84	1.930/17.082	760/	1PL6226- . . L . . - 0 ■■■■	490	6SL3320-1 TE35-0AA0
0.87	189	0.952	84	2.326/20.587	870/	1PL6228- . . L . . - 0 ■■■■	605	6SL3320-1 TE36-1AA0
Output type:		Vibration severity grade:		Shaft and flange accuracy:				
Coupling		R		N		A B C D E F G H A B C D J K 0 3 6 -Z		
Coupling		R		R				
Coupling		S		R				
Coupling		SR		R				
Belt		R		N				
Belt		R		R				
Incr. cantilever forces		R		N				
Incr. cantilever forces		R		R				
Shaft extension (DE):		Balancing:		Direction of air flow (fan):				
Fitted key		Half-key		DE → NDE				
Fitted key		Half-key		NDE → DE ⁵⁾				
Fitted key		Full-key		DE → NDE				
Fitted key		Full-key		NDE → DE ⁵⁾				
Plain shaft		-		DE → NDE				
Plain shaft		-		NDE → DE ⁵⁾				
Paint finish:								
Primed								
Anthracite (RAL 7016), standard paint finish								
Anthracite (RAL 7016), special paint finish								
Special versions:		Specify supplementary order code and plain text if applicable (see Options).						

1) n_2 : Max. permissible thermal speed at constant output or speed, which is at the voltage limit when $P = P_{\text{rated}}$.

2) n_{S1} : Max. permissible speed that is continuously permitted without speed duty cycles.

3) n_{max} : Maximum speed which must not be exceeded.

4) Speed is reduced with increased cantilever forces, see selection guides.

5) Preferred air-flow direction in polluted environment.

6) The rated output current of the Motor Module is lower than the motor rated current.

7) When ordering option **L27**, please also select option **M84** (insulated version of encoder).

8) Digit "5" for SH 225: radial ventilation; for possible designs, see table "Permissible combinations of mechanical designs on page 3/154 et seq."

9) Speed is limited to lower values in some cases. The following restriction applies: Max. output frequency < 5 × motor rated frequency.

AC motors

Asynchronous motors

1PL6 motors

Selection and ordering data

Rated speed n_{rated} rpm	Shaft height SH	Rated power P_{rated} kW/HP	Rated torque M_{rated} Nm/lb _f -ft	Rated current I_{rated} A	Rated voltage V_{rated} V	Speed during field weakening ¹⁾ n_2 rpm	Max. permissible continuous speed ²⁾ n_{S1} rpm	Max. speed ³⁾ n_{max} rpm	1PL6 asynchronous motor Order No.
400 V 3 AC line voltage, Vector Control									
400	180	24.5/32.9	585/431.1	69	300	1700	3500 ⁴⁾⁹⁾	5000 ⁹⁾	1PL6184-■ ■ B ■ ■ - 0 ...
		31.5/42.2	752/554.2	90	290	1900	3500 ⁴⁾⁹⁾	5000 ⁹⁾	1PL6186-■ ■ B ■ ■ - 0 ...
	225	45/60.4	1074/791.5	117	300	1600	3100 ⁴⁾⁹⁾	4500 ⁹⁾	1PL6224-■ ■ B ■ ■ - 0 ...
		57/76.4	1361/1003.1	145	305	1800	3100 ⁴⁾⁹⁾	4500 ⁹⁾	1PL6226-■ ■ B ■ ■ - 0 ...
		72/96.6	1719/1266.9	181	305	1800	3100 ⁴⁾⁹⁾	4500 ⁴⁾⁹⁾	1PL6228-■ ■ B ■ ■ - 0 ...
1150	180	65/87.2	540/398	121	400	2500	3500 ⁴⁾	5000	1PL6184-■ ■ D ■ ■ - 0 ...
		85/114.0	706/520.3	158	400	2700	3500 ⁴⁾	5000	1PL6186-■ ■ D ■ ■ - 0 ...
	225	120/160.9	997/734.8	218	400	2800	3100 ⁴⁾	4500	1PL6224-■ ■ D ■ ■ - 0 ...
		155/207.9	1287/948.5	275	400	2600	3100 ⁴⁾	4500	1PL6226-■ ■ D ■ ■ - 0 ...
		190/254.8	1578/1163	334	400	2500	3100 ⁴⁾	4500 ⁴⁾	1PL6228-■ ■ D ■ ■ - 0 ...
1750	180	89/119.4	486/358.2	166	400	4500	3500 ⁴⁾	5000	1PL6184-■ ■ F ■ ■ - 0 ...
		125/167.6	682/502.6	231	400	4500	3500 ⁴⁾	5000	1PL6186-■ ■ F ■ ■ - 0 ...
	225	165/221.3	900/663.3	292	400	2900	3100 ⁴⁾	4500	1PL6224-■ ■ F ■ ■ - 0 ...
		200/268.2	1091/1003.1	350	400	2900	3100 ⁴⁾	4500	1PL6226-■ ■ F ■ ■ - 0 ...
		265/355.4	1446/1065.7	470	400	2900	3100 ⁴⁾	4500 ⁴⁾	1PL6228-■ ■ F ■ ■ - 0 ...
2900	180	113/151.5	372/274.2	209	400	5000	3500 ⁴⁾	5000	1PL6184-■ ■ L ■ ■ - 0 ...
		150/201.2	494/364.1	280	390	5000	3500 ⁴⁾	5000	1PL6186-■ ■ L ■ ■ - 0 ...
	225	205/274.9	675/497.5	365	400	3500	3100 ⁴⁾	4500	1PL6224-■ ■ L ■ ■ - 0 ...
		270/362.1	889/655.2	470	400	3500	3100 ⁴⁾	4500	1PL6226-■ ■ L ■ ■ - 0 ...
		300/402.3	988/728.2	530	400	3500	3100 ⁴⁾	4500 ⁴⁾	1PL6228-■ ■ L ■ ■ - 0 ...
Fans:	External fan unit, heavy-gauge threaded cable entry in terminal box Without external fan unit, for pipe connection, heavy-gauge threaded cable entry in terminal box External fan unit, metric cable entry in terminal box Without external fan unit, for pipe connection, metric cable entry in terminal box								4 6 7 8
Encoder systems for motors without DRIVE-CLiQ interface:	Without encoder Absolute encoder EnDat 2048 pulses/revolution Incremental encoder HTL 1024 pulses/revolution Incremental encoder HTL 2048 pulses/revolution Incremental encoder sin/cos 1 V _{pp} with C and D tracks ⁷⁾ Incremental encoder sin/cos 1 V _{pp} without C and D tracks ⁷⁾ 2-pole resolver								A E H J M N R
Encoder systems for motors with DRIVE-CLiQ interface:	Absolute encoder EnDat 2048 pulses/revolution Incremental encoder sin/cos 1 V _{pp} with C and D tracks ⁷⁾ Incremental encoder sin/cos 1 V _{pp} without C and D tracks ⁷⁾ 2-pole resolver								F D Q P
Terminal box/cable entry (view onto DE):	Top/from right Top/from DE Top/from NDE Top/from left Radial ventilation for SH 225 ⁸⁾								0 1 2 3 5
Type:	IM B3 IM B3 IM B35 (SH 180: with flange A 450, SH 225: with flange A 550) IM B35 (SH 180: with flange A 450, SH 225: with flange A 550)								0 1 3 5
	Hoisting system for different construction types (IM B6, IM B7, IM B8, IM V5, IM V6)								
	Hoisting system for different construction types (IM V15, IM V36)								

Selection and ordering data

Power factor $\cos \varphi$	Magnetizing current I_{μ} A	Efficiency η_{rated}	Rated frequency f_{rated} Hz	Moment of inertia of J kgm ² / lb _f -in-s ²	Weight, approx. kg/lb	1PL6 asynchronous motor		SINAMICS S120 Motor Module	
						Order No.		Rated output current I_{rated} A	Order No.
400 V 3 AC line voltage, Vector Control									
0.86	33	0.800	14.4	0.503/4.452	370/815.85	1PL6184- . . B . . - 0 ■■■■		85	6SL3120-1 TE28-5AA1
0.85	47	0.814	14.3	0.666/5.895	440/970.2	1PL6186- . . B . . - 0 ■■■■		85 ⁶⁾	6SL3120-1 TE28-5AA1
0.87	45	0.844	14.2	1.479/13.09	630/1389.2	1PL6224- . . B . . - 0 ■■■■		132	6SL3120-1 TE31-3AA0
0.85	67	0.868	14.0	1.930/17.082	750/1653.8	1PL6226- . . B . . - 0 ■■■■		200	6SL3120-1 TE32-0AA0
0.86	77	0.871	14.0	2.326/20.587	860/1896.3	1PL6228- . . B . . - 0 ■■■■		200	6SL3120-1 TE32-0AA0
0.86	46	0.906	39.4	0.503/4.452	370/815.85	1PL6184- . . D . . - 0 ■■■■		132	6SL3120-1 TE31-3AA0
0.86	62	0.910	39.4	0.666/5.895	440/970.2	1PL6186- . . D . . - 0 ■■■■		200	6SL3120-1 TE32-0AA0
0.85	86	0.930	39.1	1.479/13.09	630/1389.2	1PL6224- . . D . . - 0 ■■■■		260	6SL3320-1 TE32-6AA0
0.87	92	0.930	39.2	1.930/17.082	750/1653.8	1PL6226- . . D . . - 0 ■■■■		310	6SL3320-1 TE33-1AA0
0.88	102	0.931	39.2	2.326/20.587	860/1896.3	1PL6228- . . D . . - 0 ■■■■		380	6SL3320-1 TE33-8AA0
0.84	68	0.921	59.3	0.503/4.452	370/815.85	1PL6184- . . F . . - 0 ■■■■		200	6SL3120-1 TE32-0AA0
0.84	92	0.935	59.3	0.666/5.895	440/970.2	1PL6186- . . F . . - 0 ■■■■		260	6SL3320-1 TE32-6AA0
0.87	90	0.942	59.2	1.479/13.09	630/1389.2	1PL6224- . . F . . - 0 ■■■■		310	6SL3320-1 TE33-1AA0
0.87	122	0.942	59.1	1.930/17.082	750/1653.8	1PL6226- . . F . . - 0 ■■■■		380	6SL3320-1 TE33-8AA0
0.86	174	0.948	59.0	2.326/20.587	860/1896.3	1PL6228- . . F . . - 0 ■■■■		490	6SL3320-1 TE35-0AA0
0.85	79	0.938	97.6	0.503/4.452	370/815.85	1PL6184- . . L . . - 0 ■■■■		210	6SL3320-1 TE32-1AA0
0.84	110	0.943	97.5	0.666/5.895	440/970.2	1PL6186- . . L . . - 0 ■■■■		310	6SL3320-1 TE33-1AA0
0.86	118	0.950	97.5	1.479/13.09	630/1389.2	1PL6224- . . L . . - 0 ■■■■		380	6SL3320-1 TE33-8AA0
0.87	160	0.952	97.4	1.930/17.082	750/1653.8	1PL6226- . . L . . - 0 ■■■■		490	6SL3320-1 TE35-0AA0
0.86	188	0.952	97.3	2.326/20.587	860/1896.3	1PL6228- . . L . . - 0 ■■■■		605	6SL3320-1 TE36-1AA0
Output type:		Vibration severity grade:		Shaft and flange accuracy:					
Coupling		R		N		A B C D E F G H			
Coupling		R		R					
Coupling		S		R					
Coupling		SR		R					
Belt		R		N					
Belt		R		R					
Incr. cantilever forces		R		N					
Incr. cantilever forces		R		R					
Shaft extension (DE):		Balancing:		Direction of air flow (fan):					
Fitted key		Half-key		DE → NDE		A B C D J K			
Fitted key		Half-key		NDE → DE ⁵⁾					
Fitted key		Full-key		DE → NDE					
Fitted key		Full-key		NDE → DE ⁵⁾					
Plain shaft		-		DE → NDE					
Plain shaft		-		NDE → DE ⁵⁾					
Paint finish:									
Primed									
Anthracite (RAL 7016), standard paint finish									
Anthracite (RAL 7016), special paint finish									
Special versions: Specify supplementary order code and plain text if applicable (see Options).									
-Z									

- n_2 : Max. permissible thermal speed at constant output or speed, which is at the voltage limit when $P = P_{\text{rated}}$.
- n_{S1} : Max. permissible speed that is continuously permitted without speed duty cycles.
- n_{max} : Maximum speed which must not be exceeded.
- Speed is reduced with increased cantilever forces, see selection guides.
- Preferred air-flow direction in polluted environment.

- The rated output current of the Motor Module is lower than the motor rated current.
- When ordering option **L27**, please also select option **M84** (insulated version of encoder).
- Digit "5" for SH 225: radial ventilation; for possible designs, see table "Permissible combinations of mechanical designs on page 3/154 et seq."
- Speed is limited to lower values in some cases. The following restriction applies: Max. output frequency < 5 × motor rated frequency.

AC motors

Asynchronous motors

1PL6 motors

Selection and ordering data

Rated speed	Shaft height SH	Rated power	Rated torque	Rated current	Rated voltage	Speed during field weakening ¹⁾	Max. permissible continuous speed ²⁾	Max. speed ³⁾	1PL6 asynchronous motor
n_{rated} rpm		P_{rated} kW/HP	M_{rated} Nm/lb _f -ft	I_{rated} A	V_{rated} V	n_2 rpm	n_{S1} rpm	n_{max} rpm	Order No.
400 V 3 AC line voltage, Vector Control									
800	280	195/261.5	2328/1715.7	335	400	1700	2200	3300	1PL6284-■ ■ C ■ ■ - 0 ...
		250/335.3	2984/2199.2	440	385	1900	2200	3300	1PL6286-■ ■ C ■ ■ - 0 ...
		310/415.7	3701/2727.6	570	370	2200	2200	3300	1PL6288-■ ■ C ■ ■ - 0 ...
1150	280	280/375.5	2325/1713.5	478	400	2200	2200	3300	1PL6284-■ ■ D ■ ■ - 0 ...
		355/476.1	2944/2169.7	637	380	2200	2200	3300	1PL6286-■ ■ D ■ ■ - 0 ...
		435/583.3	3607/2658.4	765	385	2200	2200	3300	1PL6288-■ ■ D ■ ■ - 0 ...
1750	280	370/496.2	2019/1488	616	400	2200	2200	3300	1PL6284-■ ■ F ■ ■ - 0 ...
		445/596.8	2429/1790	736	400	2200	2200	3300	1PL6286-■ ■ F ■ ■ - 0 ...
		560/751.0	3055/2251.5	924	400	2200	2200	3300	1PL6288-■ ■ F ■ ■ - 0 ...
Fans ⁴⁾:		External fan unit, NDE at top, air-flow direction NDE to DE External fan unit, NDE on right, air-flow direction NDE to DE External fan unit, NDE on left, air-flow direction NDE to DE External fan unit, DE at top, air-flow direction DE to NDE External fan unit, DE on right, air-flow direction DE to NDE External fan unit, DE on left, air-flow direction DE to NDE Without external fan unit, for single pipe connection at NDE on right							0 1 2 3 4 5 6
Encoder systems for motors without DRIVE-CLiQ interface:		Without encoder Absolute encoder EnDat 2048 pulses/revolution Incremental encoder HTL 1024 pulses/revolution Incremental encoder HTL 2048 pulses/revolution Incremental encoder sin/cos 1 V _{pp} with C and D tracks ⁶⁾ Incremental encoder sin/cos 1 V _{pp} without C and D tracks ⁶⁾ 2-pole resolver							A E H J M N R
Encoder systems for motors with DRIVE-CLiQ interface:		Absolute encoder EnDat 2048 pulses/revolution Incremental encoder sin/cos 1 V _{pp} with C and D tracks ⁶⁾ Incremental encoder sin/cos 1 V _{pp} without C and D tracks ⁶⁾ 2-pole resolver							F D Q P
Terminal box/cable entry (view onto DE) ⁴⁾:		NDE on right/from below/encoder connector DE NDE on left/from below/encoder connector DE NDE at top/from right/encoder connector DE DE at top/from right/encoder connector NDE							0 1 2 5
Type ⁴⁾:		IM B3 IM V5 (can be subsequently modified to IM V6) IM B35 (with flange A 660) IM V15 (with flange A 660; can be subsequently modified to IM V36)							0 1 3 5

Selection and ordering data

Power factor $\cos \varphi$	Magnetizing current I_{μ} A	Efficiency η_{rated}	Rated frequency f_{rated} Hz	Moment of inertia of J kgm ² / lb _r -in-s ²	Weight, approx. kg/lb	1PL6 asynchronous motor		SINAMICS S120 Motor Module	
						Order No.		Rated output current I_{rated} A	Order No.
400 V 3 AC line voltage, Vector Control									
0.90	95	0.929	27.3	4.2/37.2	1300/2866.5	1PL6284- . . C . . - 0 ■■■	380	6SL3320-1TE33-8AA0	
0.90	135	0.934	27.3	5.2/46.0	1500/3307.5	1PL6286- . . C . . - 0 ■■■	490	6SL3320-1TE35-0AA0	
0.90	170	0.939	27.3	6.3/55.8	1700/3748.5	1PL6288- . . C . . - 0 ■■■	605	6SL3320-1TE36-1AA0	
0.89	156	0.950	38.9	4.2/37.2	1300/2866.5	1PL6284- . . D . . - 0 ■■■	490	6SL3320-1TE35-0AA0	
0.89	214	0.953	38.9	5.2/46.0	1500/3307.5	1PL6286- . . D . . - 0 ■■■	745	6SL3320-1TE37-5AA0	
0.89	248	0.955	38.9	6.3/55.8	1700/3748.5	1PL6288- . . D . . - 0 ■■■	840	6SL3320-1TE38-4AA0	
0.90	162	0.959	59.0	4.2/37.2	1300/2866.5	1PL6284- . . F . . - 0 ■■■	605 ⁵⁾	6SL3320-1TE36-1AA0	
0.91	182	0.960	59.0	5.2/46.0	1500/3307.5	1PL6286- . . F . . - 0 ■■■	745	6SL3320-1TE37-5AA0	
0.91	232	0.962	59.0	6.3/55.8	1700/3748.5	1PL6288- . . F . . - 0 ■■■	985	6SL3320-1TE41-0AA0	
Output type⁴⁾:		Vibration severity grade:		Shaft and flange accuracy:					
Coupling		N		N		A			
Coupling		R		R		B			
Belt/incr. cantilever forces		N		N		E			
Belt/incr. cantilever forces		R		R		F			
Shaft extension (DE):		Balancing:				A			
Fitted key		Half-key				C			
Fitted key		Full-key				J			
Plain shaft		-							
Paint finish:						0			
Primed						3			
Anthracite (RAL 7016), standard paint finish						6			
Anthracite (RAL 7016), special paint finish									
Special versions:		Specify supplementary order code and plain text if applicable (see Options).						-Z	

1) n_2 : Max. permissible thermal speed at constant output or speed, which is at the voltage limit when $P = P_{\text{rated}}$.

2) n_{S1} : Max. permissible speed that is continuously permitted without speed duty cycles.

3) n_{max} : Maximum speed which must not be exceeded.

4) See Table "Permissible combinations of mechanical designs".

5) The rated output current of the Motor Module is lower than the motor rated current.

6) Only in conjunction with option **M84** (insulated version of encoder).

AC motors

Asynchronous motors

1PL6 motors

Selection and ordering data

Rated speed n_{rated} rpm	Shaft height SH	Rated power P_{rated} kW/HP	Rated torque M_{rated} Nm/lb _r -ft	Rated current I_{rated} A	Rated voltage V_{rated} V	Speed during field weakening ¹⁾ n_2 rpm	Max. permissible continuous speed ²⁾ n_{S1} rpm	Max. speed ³⁾ n_{max} rpm	1PL6 asynchronous motor Order No.
480 V 3 AC line voltage, Servo/Vector Control									
500	180	30/40.2	573/422.3	66	370	1900	3500 ⁴⁾⁹⁾	5000 ⁹⁾	1PL6184-■ ■ B ■ ■ - 0 ...
		40/53.6	764/563.1	91	355	2000	3500 ⁴⁾⁹⁾	5000 ⁹⁾	1PL6186-■ ■ B ■ ■ - 0 ...
	225	55/73.8	1050/773.9	114	370	1800	3100 ⁴⁾⁹⁾	4500 ⁹⁾	1PL6224-■ ■ B ■ ■ - 0 ...
		72/96.6	1375/1013.4	147	375	2000	3100 ⁴⁾⁹⁾	4500 ⁹⁾	1PL6226-■ ■ B ■ ■ - 0 ...
1350	180	90/120.7	1719/1266.9	180	380	1900	3100 ⁴⁾⁹⁾	4500 ⁴⁾⁹⁾	1PL6228-■ ■ B ■ ■ - 0 ...
		74/99.2	523/385.5	119	460	3000	3500 ⁴⁾	5000	1PL6184-■ ■ D ■ ■ - 0 ...
	225	98/131.4	693/510.7	156	460	3100	3500 ⁴⁾	5000	1PL6186-■ ■ D ■ ■ - 0 ...
		137/183.7	969/714.2	215	460	3300	3100 ⁴⁾	4500	1PL6224-■ ■ D ■ ■ - 0 ...
2000	180	172/230.7	1217/896.9	265	460	3200	3100 ⁴⁾	4500	1PL6226-■ ■ D ■ ■ - 0 ...
		218/292.3	1542/1136.5	332	460	2900	3100 ⁴⁾	4500 ⁴⁾	1PL6228-■ ■ D ■ ■ - 0 ...
	225	98/131.4	468/344.9	161	460	5000	3500 ⁴⁾	5000	1PL6184-■ ■ F ■ ■ - 0 ...
		135/181.0	645/475.4	220	460	5000	3500 ⁴⁾	5000	1PL6186-■ ■ F ■ ■ - 0 ...
2900	180	178/238.7	850/626.5	275	460	2900	3100 ⁴⁾	4500	1PL6224-■ ■ F ■ ■ - 0 ...
		220/131.4	1050/773.9	342	460	2900	3100 ⁴⁾	4500	1PL6226-■ ■ F ■ ■ - 0 ...
	225	288/386.2	1375/1013.4	450	460	2900	3100 ⁴⁾	4500 ⁴⁾	1PL6228-■ ■ F ■ ■ - 0 ...
		113/151.5	372/274.2	209	400	5000	3500 ⁴⁾	5000	1PL6184-■ ■ L ■ ■ - 0 ...
3	180	150/201.2	494/364.1	280	390	5000	3500 ⁴⁾	5000	1PL6186-■ ■ L ■ ■ - 0 ...
		205/274.9	675/497.5	365	400	3500	3100 ⁴⁾	4500	1PL6224-■ ■ L ■ ■ - 0 ...
	225	270/362.1	889/655.2	470	395	3500	3100 ⁴⁾	4500	1PL6226-■ ■ L ■ ■ - 0 ...
		300/402.3	988/728.2	530	400	3500	3100 ⁴⁾	4500 ⁴⁾	1PL6228-■ ■ L ■ ■ - 0 ...
Fans:	External fan unit, heavy-gauge threaded cable entry in terminal box Without external fan unit, for pipe connection, heavy-gauge threaded cable entry in terminal box External fan unit, metric cable entry in terminal box Without external fan unit, for pipe connection, metric cable entry in terminal box								4 6 7 8
Encoder systems for motors without DRIVE-CLiQ interface:	Without encoder Absolute encoder EnDat 2048 pulses/revolution Incremental encoder HTL 1024 pulses/revolution Incremental encoder HTL 2048 pulses/revolution Incremental encoder sin/cos 1 V _{pp} with C and D tracks ⁷⁾ Incremental encoder sin/cos 1 V _{pp} without C and D tracks ⁷⁾ 2-pole resolver								A E H J M N R
Encoder systems for motors with DRIVE-CLiQ interface:	Absolute encoder EnDat 2048 pulses/revolution Incremental encoder sin/cos 1 V _{pp} with C and D tracks ⁷⁾ Incremental encoder sin/cos 1 V _{pp} without C and D tracks ⁷⁾ 2-pole resolver								F D Q P
Terminal box/cable entry (view onto DE):	Top/from right Top/from DE Top/from NDE Top/from left Radial ventilation for SH 225 ⁸⁾								0 1 2 3 5
Type:	IM B3 IM B3 IM B35 (SH 180: with flange A 450, SH 225: with flange A 550) IM B35 (SH 180: with flange A 450, SH 225: with flange A 550)								0 1 3 5

Selection and ordering data

Power factor $\cos \varphi$	Magnetizing current I_{μ} A	Efficiency η_{rated}	Rated frequency f_{rated} Hz	Moment of inertia of J kgm ² / lb _f -in-s ²	Weight, approx. kg/lb	1PL6 asynchronous motor		SINAMICS S120 Motor Module					
						Order No.		Rated output current A	Order No.				
480 V 3 AC line voltage, Servo/Vector Control													
0.84	34	0.844	17.6	0.503/4.452	370/815.85	1PL6184- . . B . . - 0 ■■■■		85	6SL3120-1TE28-5AA1				
0.84	46	0.845	17.6	0.666/5.895	440/970.2	1PL6186- . . B . . - 0 ■■■■		132	6SL3120-1TE31-3AA0				
0.86	46	0.875	17.5	1.479/13.09	630/1389.2	1PL6224- . . B . . - 0 ■■■■		132	6SL3120-1TE31-3AA0				
0.85	66	0.887	17.4	1.930/17.082	750/1653.8	1PL6226- . . B . . - 0 ■■■■		200	6SL3120-1TE32-0AA0				
0.85	79	0.894	17.4	2.326/20.587	860/1896.3	1PL6228- . . B . . - 0 ■■■■		200	6SL3120-1TE32-0AA0				
0.86	44	0.918	46.1	0.503/4.452	370/815.85	1PL6184- . . D . . - 0 ■■■■		132	6SL3120-1TE31-3AA0				
0.85	60	0.920	46.0	0.666/5.895	440/970.2	1PL6186- . . D . . - 0 ■■■■		200	6SL3120-1TE32-0AA0				
0.85	82	0.940	45.8	1.479/13.09	630/1389.2	1PL6224- . . D . . - 0 ■■■■		210 ⁶⁾	6SL3320-1TE32-1AA0				
0.87	88	0.940	45.8	1.930/17.082	750/1653.8	1PL6226- . . D . . - 0 ■■■■		260 ⁶⁾	6SL3320-1TE32-6AA0				
0.88	100	0.938	45.8	2.326/20.587	860/1896.3	1PL6228- . . D . . - 0 ■■■■		380	6SL3320-1TE33-8AA0				
0.83	70	0.934	67.5	0.503/4.452	370/815.85	1PL6184- . . F . . - 0 ■■■■		200	6SL3120-1TE32-0AA0				
0.83	94	0.940	67.5	0.666/5.895	440/970.2	1PL6186- . . F . . - 0 ■■■■		260	6SL3320-1TE32-6AA0				
0.86	91	0.944	67.5	1.479/13.09	630/1389.2	1PL6224- . . F . . - 0 ■■■■		310	6SL3320-1TE33-1AA0				
0.86	124	0.948	67.5	1.930/17.082	750/1653.8	1PL6226- . . F . . - 0 ■■■■		380	6SL3320-1TE33-8AA0				
0.85	176	0.948	67.3	2.326/20.587	860/1896.3	1PL6228- . . F . . - 0 ■■■■		490	6SL3320-1TE35-0AA0				
0.85	79	0.938	97.6	0.503/4.452	370/815.85	1PL6184- . . L . . - 0 ■■■■		210	6SL3320-1TE32-1AA0				
0.84	110	0.943	97.5	0.666/5.895	440/970.2	1PL6186- . . L . . - 0 ■■■■		310	6SL3320-1TE33-1AA0				
0.86	118	0.950	97.5	1.479/13.09	630/1389.2	1PL6224- . . L . . - 0 ■■■■		380	6SL3320-1TE33-8AA0				
0.87	160	0.952	97.4	1.930/17.082	750/1653.8	1PL6226- . . L . . - 0 ■■■■		490	6SL3320-1TE35-0AA0				
0.86	188	0.952	97.3	2.326/20.587	860/1896.3	1PL6228- . . L . . - 0 ■■■■		605	6SL3320-1TE36-1AA0				
Output type:		Vibration severity grade:		Shaft and flange accuracy:									
Coupling		R		N		A B C D E F G H							
Coupling		R		R									
Coupling		S		R									
Coupling		SR		R									
Belt		R		N									
Belt		R		R									
Increased cantilever forces		R		N									
Increased cantilever forces		R		R									
Shaft extension (DE):		Balancing:		Direction of air flow (fan):						A B C D J K			
Fitted key		Half-key		DE → NDE									
Fitted key		Half-key		NDE → DE ⁵⁾									
Fitted key		Full-key		DE → NDE									
Fitted key		Full-key		NDE → DE ⁵⁾									
Plain shaft		–		DE → NDE									
Plain shaft		–		NDE → DE ⁵⁾									
Paint finish:													
Primed		0											
Anthracite (RAL 7016), standard paint finish		3											
Anthracite (RAL 7016), special paint finish		6											
Special versions:		Specify supplementary order code and plain text if applicable. (see Options).							-Z				

1) n_2 : Max. permissible thermal speed at constant output or speed, which is at the voltage limit when $P = P_{\text{rated}}$.

2) n_{S1} : Max. permissible speed that is continuously permitted without speed duty cycles.

3) n_{max} : Maximum speed which must not be exceeded.

4) Speed is reduced with increased cantilever forces, see selection guides.

5) Preferred air-flow direction in polluted environment.

6) The rated output current of the Motor Module is lower than the motor rated current.

7) When ordering option **L27**, please also select option **M84** (insulated version of encoder).

8) Digit "5" for SH 225: radial ventilation; for possible designs, see table "Permissible combinations of mechanical designs on page 3/154 et seq."

9) Speed is limited to lower values in some cases. The following restriction applies: Max. output frequency < 5 × motor rated frequency.

AC motors

Asynchronous motors

1PL6 motors

Selection and ordering data

Rated speed	Shaft height SH	Rated power	Rated torque	Rated current	Rated voltage	Speed during field weakening ¹⁾	Max. permissible continuous speed ²⁾	Max. speed ³⁾	1PL6 asynchronous motor
n_{rated} rpm		P_{rated} kW/HP	M_{rated} Nm/lb _f -ft	I_{rated} A	V_{rated} V	n_2 rpm	n_{S1} rpm	n_{max} rpm	Order No.
480 V 3 AC line voltage, Servo/Vector Control									
1000	280	235/315.1	2244/1653.8	335	480	2200	2200	3300	1PL6284-■ ■ C ■ ■ - 0 ...
		310/415.7	2961/2182.3	440	480	2200	2200	3300	1PL6286-■ ■ C ■ ■ - 0 ...
		385/516.3	3677/2709.9	570	460	2200	2200	3300	1PL6288-■ ■ C ■ ■ - 0 ...
1350	280	325/435.8	2299/1694.4	478	470	2200	2200	3300	1PL6284-■ ■ D ■ ■ - 0 ...
		410/549.8	2901/2138.0	637	445	2200	2200	3300	1PL6286-■ ■ D ■ ■ - 0 ...
		505/677.2	3573/2633.3	765	450	2200	2200	3300	1PL6288-■ ■ D ■ ■ - 0 ...
2000	280	415/556.5	1981/1460.0	616	455	2200	2200	3300	1PL6284-■ ■ F ■ ■ - 0 ...
		500/670.5	2387/1759.2	736	455	2200	2200	3300	1PL6286-■ ■ F ■ ■ - 0 ...
		630/844.8	3009/2217.6	924	455	2200	2200	3300	1PL6288-■ ■ F ■ ■ - 0 ...
Fans ⁴⁾:	External fan unit, NDE at top, air-flow direction NDE to DE External fan unit, NDE on right, air-flow direction NDE to DE External fan unit, NDE on left, air-flow direction NDE to DE External fan unit, DE at top, air-flow direction DE to NDE External fan unit, DE on right, air-flow direction DE to NDE External fan unit, DE on left, air-flow direction DE to NDE Without external fan unit, for single pipe connection at NDE on right								0 1 2 3 4 5 6
Encoder systems for motors without DRIVE-CLiQ interface:	Without encoder Absolute encoder EnDat 2048 pulses/revolution Incremental encoder HTL 1024 pulses/revolution Incremental encoder HTL 2048 pulses/revolution Incremental encoder sin/cos 1 V _{pp} with C and D tracks ⁶⁾ Incremental encoder sin/cos 1 V _{pp} without C and D tracks ⁶⁾ 2-pole resolver								A E H J M N R
Encoder systems for motors with DRIVE-CLiQ interface:	Absolute encoder EnDat 2048 pulses/revolution Incremental encoder sin/cos 1 V _{pp} with C and D tracks ⁶⁾ Incremental encoder sin/cos 1 V _{pp} without C and D tracks ⁶⁾ 2-pole resolver								F D Q P
Terminal box/cable entry (view onto DE) ⁴⁾:	NDE on right/from below/encoder connector DE NDE on left/from below/encoder connector DE NDE at top/from right/encoder connector DE DE at top/from right/encoder connector NDE								0 1 2 5
Type ⁴⁾:	IM B3 IM V5 (can be subsequently modified to IM V6) IM B35 (with flange A 660) IM V15 (with flange A 660; can be subsequently modified to IM V36)								0 1 3 5

Selection and ordering data

Power factor $\cos \varphi$	Magnetizing current I_{μ} A	Efficiency η_{rated}	Rated frequency f_{rated} Hz	Moment of inertia of J kgm ² / lb _f -in-s ²	Weight, approx. kg/lb	1PL6 asynchronous motor		SINAMICS S120 Motor Module	
						Order No.		Rated output current I_{rated} A	Order No.
480 V 3 AC line voltage, Servo/Vector Control									
0.90	90	0.939	34.0	4.2/37.173	1300/2866.5	1PL6284- . . C . . - 0 ■■■	380	6SL3320-1TE33-8AA0	
0.90	135	0.945	34.0	5.2/46.02	1500/3307.5	1PL6286- . . C . . - 0 ■■■	490	6SL3320-1TE35-0AA0	
0.90	170	0.948	34.0	6.3/55.76	1700/3748.5	1PL6288- . . C . . - 0 ■■■	605	6SL3320-1TE36-1AA0	
0.89	157	0.955	45.5	4.2/37.173	1300/2866.5	1PL6284- . . D . . - 0 ■■■	490	6SL3320-1TE35-0AA0	
0.89	215	0.957	45.5	5.2/46.02	1500/3307.5	1PL6286- . . D . . - 0 ■■■	745	6SL3320-1TE37-5AA0	
0.89	248	0.959	45.5	6.3/55.76	1700/3748.5	1PL6288- . . D . . - 0 ■■■	840	6SL3320-1TE38-4AA0	
0.90	161	0.961	67.3	4.2/37.173	1300/2866.5	1PL6284- . . F . . - 0 ■■■	745	6SL3320-1TE37-5AA0	
0.91	181	0.963	67.3	5.2/46.02	1500/3307.5	1PL6286- . . F . . - 0 ■■■	745	6SL3320-1TE37-5AA0	
0.91	231	0.965	67.3	6.3/55.76	1700/3748.5	1PL6288- . . F . . - 0 ■■■	985	6SL3320-1TE41-0AA0	
Output type ⁴⁾:		Vibration severity grade:		Shaft and flange accuracy:					
Coupling		N		N		A			
Coupling		R		R		B			
Belt/increased cantilever forces		N		N		E			
Belt/increased cantilever forces		R		R		F			
Shaft extension (DE):		Balancing:				A			
Fitted key		Half-key				C			
Fitted key		Full-key				J			
Plain shaft		-							
Paint finish:						0			
Primed						3			
Anthracite (RAL 7016), standard paint finish						6			
Anthracite (RAL 7016), special paint finish									
Special versions:		Specify supplementary order code and plain text if applicable (see Options).						-Z	

1) n_2 : Max. permissible thermal speed at constant output or speed, which is at the voltage limit when $P = P_{\text{rated}}$.

2) n_{S1} : Max. permissible speed that is continuously permitted without speed duty cycles.

3) n_{max} : Maximum speed which must not be exceeded.

4) See Table "Permissible combinations of mechanical designs".

5) The rated output current of the Motor Module is lower than the motor rated current.

6) Only in conjunction with option **M84** (insulated version of encoder).

AC motors

Asynchronous motors

1PL6 motors

Selection and ordering data

Rated speed	Shaft height SH	Rated power	Rated torque	Rated current	Rated voltage	Speed during field weakening ¹⁾	Max. permissible continuous speed ²⁾	Max. speed ³⁾	1PL6 asynchronous motor
n_{rated} rpm		P_{rated} kW/HP	M_{rated} Nm/lb _f -ft	I_{rated} A	V_{rated} V	n_2 rpm	n_{S1} rpm	n_{max} rpm	Order No.
690 V 3 AC line voltage, Servo/Vector Control									
800	280	185/248.1	2208/1627.3	185	690	2000	2200	3300	1PL6284-■ ■ C ■ ■ - 0 ...
		240/321.8	2865/2111.5	250	665	2100	2200	3300	1PL6286-■ ■ C ■ ■ - 0 ...
		300/402.3	3581/2639.2	320	640	2200	2200	3300	1PL6288-■ ■ C ■ ■ - 0 ...
1150	280	272/364.8	2259/1664.9	270	690	2200	2200	3300	1PL6284-■ ■ D ■ ■ - 0 ...
		344/461.3	2857/2105.6	359	655	2200	2200	3300	1PL6286-■ ■ D ■ ■ - 0 ...
		422/565.9	3504/2582.4	431	665	2200	2200	3300	1PL6288-■ ■ D ■ ■ - 0 ...
1750	280	359/481.4	1959/1443.8	347	690	2200	2200	3300	1PL6284-■ ■ F ■ ■ - 0 ...
		432/579.3	2357/1737.1	415	690	2200	2200	3300	1PL6286-■ ■ F ■ ■ - 0 ...
		543/728.2	2963/2183.7	520	690	2200	2200	3300	1PL6288-■ ■ F ■ ■ - 0 ...
Fans ⁵⁾:	External fan unit, NDE top, air-flow direction NDE to DE External fan unit, NDE right, air-flow direction NDE to DE External fan unit, NDE left, air-flow direction NDE to DE External fan unit, DE top, air-flow direction DE to NDE External fan unit, DE right, air-flow direction DE to NDE External fan unit, DE left, air-flow direction DE to NDE Without external fan unit, for single pipe connection at NDE right								0 1 2 3 4 5 6
Encoder systems for motors without DRIVE-CLiQ interface:	Without encoder Absolute encoder EnDat 2048 pulses/revolution Incremental encoder HTL 1024 pulses/revolution Incremental encoder HTL 2048 pulses/revolution Incremental encoder sin/cos 1 V _{pp} with C and D tracks ⁶⁾ Incremental encoder sin/cos 1 V _{pp} without C and D tracks ⁶⁾ 2-pole resolver								A E H J M N R
Encoder systems for motors with DRIVE-CLiQ interface:	Absolute encoder EnDat 2048 pulses/revolution Incremental encoder sin/cos 1 V _{pp} with C and D tracks ⁶⁾ Incremental encoder sin/cos 1 V _{pp} without C and D tracks ⁶⁾ 2-pole resolver								F D Q P
Terminal box/cable entry (view onto DE) ⁵⁾:	NDE right/from below/encoder connector DE NDE left/from below/encoder connector DE NDE top/from right/encoder connector DE DE top/from right/encoder connector NDE								0 1 2 5
Type ⁵⁾:	IM B3 IM V5 (can be subsequently modified to IM V6) IM B35 (with flange A 660) IM V15 (with flange A 660, can be subsequently modified to IM V36)								0 1 3 5

Selection and ordering data

Power factor $\cos \varphi$	Magnetizing current I_{μ} A	Efficiency η_{rated}	Rated frequency f_{rated} Hz	Moment of inertia of J kgm ² / lb _r -in-s ²	Weight, approx. kg/lb	1PL6 asynchronous motor		SINAMICS S120 Motor Module Rated output current	
						Order No.	I_{rated} A	Order No.	
690 V 3 AC line voltage, Servo/Vector Control									
0.90	55	0.928	27	4.2/37.173	1300/2866.5	1PL6284- . . C . . - 0 ■■■	215	6SL3320-1T H32-2AA0	
0.90	80	0.934	27	5.2/46.02	1500/3307.5	1PL6286- . . C . . - 0 ■■■	260	6SL3320-1T H32-6AA0	
0.90	100	0.938	27	6.3/55.76	1700/3748.5	1PL6288- . . C . . - 0 ■■■	330	6SL3320-1T H33-3AA0	
0.89	89	0.949	38.9	4.2/37.173	1300/2866.5	1PL6284- . . D . . - 0 ■■■	330	6SL3320-1T H33-3AA0	
0.89	123	0.953	38.9	5.2/46.02	1500/3307.5	1PL6286- . . D . . - 0 ■■■	410	6SL3320-1T H34-1AA0	
0.89	143	0.955	38.9	6.3/55.76	1700/3748.5	1PL6288- . . D . . - 0 ■■■	465	6SL3320-1T H34-7AA0	
0.90	93	0.958	59	4.2/37.173	1300/2866.5	1PL6284- . . F . . - 0 ■■■	410	6SL3320-1T H34-1AA0	
0.91	105	0.960	59	5.2/46.02	1500/3307.5	1PL6286- . . F . . - 0 ■■■	410 ⁴⁾	6SL3320-1T H34-1AA0	
0.91	133	0.962	59	6.3/55.76	1700/3748.5	1PL6288- . . F . . - 0 ■■■	575	6SL3320-1T H35-8AA0	
Output type⁵⁾:		Vibration severity grade:		Shaft and flange accuracy:					
Coupling		N		N		A			
Coupling		R		R		B			
Belt/increased cantilever forces		N		N		E			
Belt/increased cantilever forces		R		R		F			
Shaft extension (DE):		Balancing:				A			
Fitted key		Half-key				C			
Fitted key		Full-key				J			
Plain shaft		-							
Paint finish:						0			
Primed						3			
Anthracite (RAL 7016), standard paint finish						6			
Anthracite (RAL 7016), special paint finish									
Special versions:		Specify supplementary order code and plain text if applicable (see Options).				-Z			
		C30 absolutely essential							

1) n_2 : Max. permissible thermal speed at constant output or speed, which is at the voltage limit when $P = P_{\text{rated}}$.

2) n_{S1} : Max. permissible speed that is continuously permitted without speed duty cycles.

3) n_{max} : Maximum speed which must not be exceeded.

4) The rated output current of the Motor Module is lower than the motor rated current.

5) See Table "Permissible combinations of mechanical designs".

6) Only in conjunction with option **M84** (insulated version of encoder).

AC motors

Asynchronous motors

Permissible combinations of mechanical designs for 1PL6 motors, shaft height 225

Selection and ordering data

Permissible combinations of mechanical designs, radial ventilation

1PL6 2... motors Shaft height 225

Position in order no. 1PL6224 1PL6226 1PL6228	8.	9.	10.	11.	12.	13.	14.	15.	16.	External fan unit, radially -Z			
	External fan unit			Radial ventilation ²⁾	Type of construction (IM B3 and IM B35)			Air-flow direction NDE → DE, shaft end			G04	G02	G00
	-	■	.	.	■	■	-	■	.		NDE at top, air inlet from NDE, air-flow direction NDE → DE	NDE on right, air inlet from NDE, air-flow direction NDE → DE	NDE on left, air inlet from NDE, air-flow direction NDE → DE
with external fan unit	-	4 7	.	.	5	0 3	-	.	B D K	.			
without external fan unit, for pipe connection	-	6 8	.	.	5	0 3	-	.	B D K	.			

Order codes for options

R1Y Standard finish RAL ...			
R2Y Special finish RAL ...			
G14 With air filter			
G80 POG10 pulse encoder, mounting prepared (encoder is supplied)			
K55 Cable entry plate, terminal box, customer-specific ¹⁾			
K16 Second standard shaft end (possible only for encoderless systems)		on request	
K31 Second rating plate			
Y55 Non-standard shaft extension DE			
K40 230 V standstill heating		on request	
L27 NDE bearing in insulated design			
Y80 Different rating plate data ¹⁾		on request	
Y82 Extra rating plate with customer data		on request	

Standard version
 Released supplementary versions

¹⁾ Plain text is necessary

²⁾ Cable entry direction for **K09**: Power DE, encoder connector at top
 Cable entry direction for **K10**: Power DE, encoder connector at top
 Cable entry direction for **K11**: Cable entry on right, encoder connector DE

AC motors

Asynchronous motors

Permissible combinations of mechanical designs
for 1PL6 motors, shaft height 225

Terminal box arrangement -Z

K09	K10	K11
NDE on right (view onto DE)	NDE on left (view onto DE)	NDE at top (view onto DE)

Cable entries -Z

K08	K83	K84	K85
Encoder connector mounted opposite	Rotation of terminal box through +90°	Rotation of terminal box through -90°	Rotation of terminal box through 180°

3

AC motors

Asynchronous motors

Permissible combinations of mechanical designs for 1PL6 motors, shaft height 280

Selection and ordering data

Permissible combinations of mechanical designs

1PL6 28 . motors
Shaft height 280

Position in order no. 8. 9. 10. 11. 12. 13. 14. 15. 16.
1PL628. - ■ . . . ■ ■ - . ■ . .

Permissible combinations of mechanical designs

External fan unit
8th position in order no.
1PL628. - ■

Order No. supplement

0	1	2	3	4	5	6
NDE at top NDE → DE	NDE on right NDE → DE	NDE on left NDE → DE	DE at top DE → NDE	DE on right DE → NDE	DE on left DE → NDE	Single pipe connection NDE on right (can be modified subsequently to NDE left)

1PL628. - 0 - Type of construction IM B3

1PL628. - 1 - Type of construction IM V5
(can be modified subsequently to IM V6)

1PL628. - 3 - Type construction IM B35

1PL628. - 5 - Type construction IM V15
(can be modified subsequently to IM V36)

Order codes for options

- R1Y Standard finish RAL ...
- R2Y Special finish RAL ...
- G14 With air filter
- K08 Encoder connector mounted opposite
- K55 Cable entry plate, terminal box, customer-specific ¹⁾
- K83 Terminal box rotated through +90 degrees
- K84 Terminal box rotated through -90 degrees
- K85 Terminal box rotated through 180 degrees
- K16 Second standard shaft end (possible only for encoderless systems)
- K31 Second rating plate
- K45 230 V standstill heating
- C30 690 V version
- Y55 Non-standard shaft extension DE
- Y80 Different rating plate data ¹⁾
- Y82 Extra rating plate with customer data ¹⁾
- M83 Additional thread for a setting screw on motor feet

Standard version
Released supplementary versions

¹⁾ Plain text is necessary

AC motors

Asynchronous motors

Permissible combinations of mechanical designs
for 1PL6 motors, shaft height 280

Terminal box
11th position in order no.
1PL628 . - . . . ■ . -

Construction type
12th position in order no.
1PL628 . - . . . ■ . -

Drive type
14th position in order no.
1PL628 . - - . ■ . . .

Order No. supplement

Order No. supplement

Order No. supplement

Order No. supplement				Order No. supplement				Order No. supplement			
0	1	2	5	0	1	3	5	A	B	E	F
NDE on right Cable entry at bottom, encoder connector DE	NDE on left Cable entry at bottom, encoder connector DE	NDE at top Cable entry on right, encoder connector DE	DE at top Cable entry on right, encoder connector NDE	Construction type IM B3	Construction type IM V5 (IM V6)	Construction type IM B35	Construction type IM V15 (IM V36)	Coupling N/N	Coupling R/R	Belt/ increased cantilever forces N/N	Belt/ increased cantilever forces R/R

3

AC motors

Asynchronous motors

Selection guides for 1PH7 and 1PL6 motors Ventilation data and sound pressure level

Ventilation data and sound pressure level

Shaft height SH	Fan motor: Current consumption at			Direction of air flow	Sound pressure level L_{pA} Motor + external fan unit Rated load, 50 Hz Tolerance +3 dB 1 dB(A)	Air flow rate at 50 Hz approx. m^3/s
	400 V/50 Hz ($\pm 10\%$)	400 V/60 Hz ($\pm 10\%$)	480 V/60 Hz (+5%, -10%)			
1PH7 motors						
100	0.19	0.13	0.18	NDE → DE	70	0.04
	0.20	0.13	0.20	DE → NDE	70	0.04
132	0.35	0.24	0.32	NDE → DE	70	0.10
	0.37	0.24	0.33	DE → NDE	70	0.10
160	0.29	0.31	0.33	NDE → DE	72	0.15
	0.3	0.33	0.34	DE → NDE	75	0.15
180	0.8	1.1	1.1	NDE → DE, DE → NDE	73	0.19
	1.9	2.2	2.2	NDE → DE	74	0.36
225	2.8	2.8	2.8	DE → NDE	76	0.36
	2.55	2.6	2.6	NDE → DE, DE → NDE	74	0.42
1PL6 motors						
180	0.8	1.1	1.1	NDE → DE, DE → NDE	73 ¹⁾	0.27
225	1.9	2.2	2.2	NDE → DE	74 ¹⁾	0.38
	2.8	2.8	2.8	DE → NDE	76 ¹⁾	0.38
280	2.55	2.6	2.6	NDE → DE, DE → NDE	74 ¹⁾	0.52

¹⁾ Speed range 0 to 2000 rpm.

Bearing design/drive type and maximum speeds

Shaft height/ motor type	Bearing type/ drive type	Bearing arrangement		Max. continuous speed for S1 duty		Max. speed limit ¹⁾	
		Motor end	Bearing designation	n_{s1}	$n_{s1}^{2)}$	$n_{max.}$	$n_{max.}^{2)}$
				rpm	rpm	rpm	rpm
100	Deep-groove ball bearings for coupling or belt output	DE	6308 C4	5500	10000	9000	12000
		NDE	6208 C4				
132	Deep-groove ball bearings for coupling or belt output	DE	6310 C4	4500	8500	8000	10000
		NDE	6210 C4				
160	Deep-groove ball bearings for coupling or belt output	DE	6312 C4	3700	7000	6500	8000
		NDE	6212 C4				
180	Deep-groove ball bearings for coupling output	DE	6214 C3	3500	4500	5000	7000
		NDE	6214 C3				
	Cylindrical roller bearings for belt output	DE	NU22 14E	3500	–	5000	–
		NDE	6214 C3				
	Cylindrical roller bearings for increased cantilever forces	DE	NU22 14E	3000	–	5000	–
		NDE	6214 C3				
225	Deep-groove ball bearings for coupling output	DE	6216 C3	3100	3600 (for 1PH7224)	4500	5500 (for 1PH7224)
		NDE	6216 C3				
	Cylindrical roller bearings for belt output	DE	NU22 16E	3100	–	4500	–
		NDE	6216 C3				
Type 224, 226	Cylindrical roller bearings for increased cantilever forces	DE	NU22 16E	2700	–	4500	–
		NDE	6216 C3				
Type 228	Cylindrical roller bearings for increased cantilever forces	DE	NU22 16E	2500	–	4000	–
		NDE	6216 C3				
280	Deep-groove ball bearings for coupling output	DE	6220 C3	2200	–	3300	–
		NDE	6220 C3				
	Cylindrical roller bearings for belt output	DE	NU22 0E	2200	–	3300	–
		NDE	6220 C3				

Bearing service life

The bearing service life is limited by material fatigue (fatigue service life) or lubrication failure (grease lifetime).

The fatigue service life (static bearing service life L_{10h}) is primarily dependent on the mechanical load. This correlation can be seen in the cantilever force/axial force diagrams. The values are determined according to DIN/ISO 281.

The bearing lifetime is mainly dependent on the bearing size, speed, temperature, as well as the vibrational load.

The bearing lifetime can be extended by especially favorable operating conditions (low average speed, low bearing temperature, cantilever force or vibration load).

A reduction can be expected for difficult operating conditions and when motors are mounted vertically.

Further information can be found in the Planning Guides.

Lubrication for entire service life

For permanent lubrication, the bearing lifetime is coordinated with the bearing service life.

In the basic version, motors up to and including shaft height 225 have lubrication for entire service life.

Regreasing

For motors which can be regreased at defined regreasing intervals, the bearing service life can be extended and/or unfavorable factors such as mounting conditions, speed, bearing size and mechanical load compensated.

A lubricating nipple for regreasing is provided as standard on motors with SH 280.

A lubricating nipple for regreasing can be ordered as an optional extra for motors with SH 180 and 225, order code **K40**.

¹⁾ For continuous operation (with 30% n_{max} , 60% $^{2/3} n_{max}$, 10% standstill) for a duty cycle duration of 10 min.

²⁾ Version for increased maximum speed, see selection and ordering data for 1PH7.

AC motors

Asynchronous motors

Selection guides for 1PH7 and 1PL6 motors

Cantilever force diagrams

Cantilever force diagrams

Permissible cantilever forces 1PH7 motors Shaft height 100

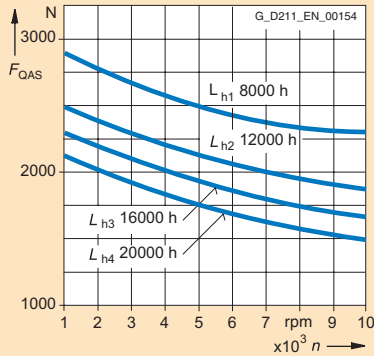
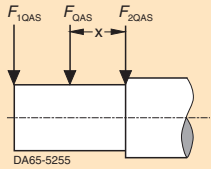

$x = 40 \text{ mm (1.57 in)}$
 $F_{1QAS} = 0.9 F_{QAS}$
 $F_{2QAS} = 1.1 F_{QAS}$
 $L_{h1}, L_{h2}, L_{h3}, L_{h4}$ = lifetime estimate for variable operating conditions ($F_{QAS}; n$)
 q = period of efficiency [%] under constant conditions

$$L_{10hges} = \frac{100}{\frac{q_1}{L_{h1}} + \frac{q_2}{L_{h2}} + \frac{q_3}{L_{h3}} + \frac{q_4}{L_{h4}}}$$

Permissible cantilever forces 1PH7 motors Shaft height 132

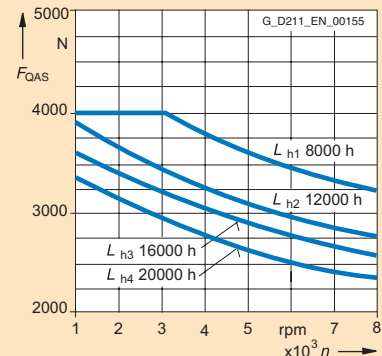
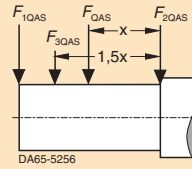

$x = 55 \text{ mm (2.17 in)}$
 $F_{1QAS} = \text{max. } 2000 \text{ N (449.62 lb}_f\text{)}$
 $F_{2QAS} = 1.1 F_{QAS}$
 $F_{3QAS} = \text{max. } 2500 \text{ N (562.03 lb}_f\text{)}$
 $L_{h1}, L_{h2}, L_{h3}, L_{h4}$ = lifetime estimate for variable operating conditions ($F_{QAS}; n$)
 q = period of efficiency [%] under constant conditions

$$L_{10hges} = \frac{100}{\frac{q_1}{L_{h1}} + \frac{q_2}{L_{h2}} + \frac{q_3}{L_{h3}} + \frac{q_4}{L_{h4}}}$$

Permissible cantilever forces 1PH7 motors Shaft height 160

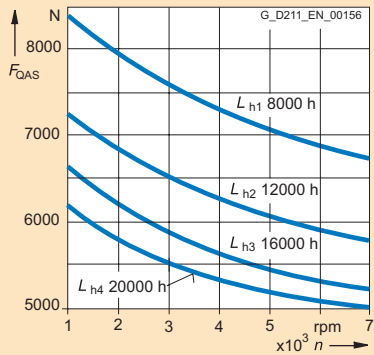
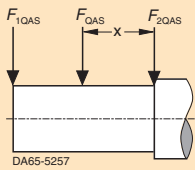

$x = 55 \text{ mm (2.17 in)}$
 $F_{1QAS} = 0.9 F_{QAS}$
 $F_{2QAS} = 1.1 F_{QAS}$
 $L_{h1}, L_{h2}, L_{h3}, L_{h4}$ = lifetime estimate for variable operating conditions ($F_{QAS}; n$)
 q = period of efficiency [%] under constant conditions

$$L_{10hges} = \frac{100}{\frac{q_1}{L_{h1}} + \frac{q_2}{L_{h2}} + \frac{q_3}{L_{h3}} + \frac{q_4}{L_{h4}}}$$

Permissible cantilever forces 1PH718 and 1PL618 motors. Shaft height 180 for coupling output

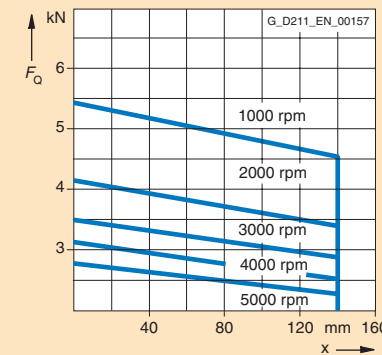
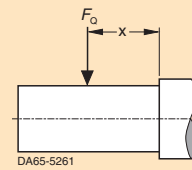

$L_{10h} = 20000 \text{ h}$

Permissible cantilever forces 1PH722 and 1PL622 motors. Shaft height 225 for coupling output

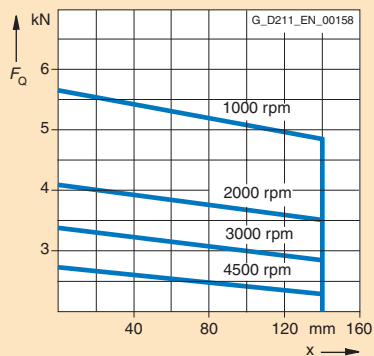
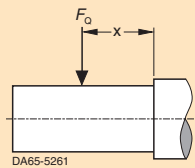

$L_{10h} = 20000 \text{ h}$

Permissible cantilever forces 1PH718 and 1PL618 motors. Shaft height 180 for belt output

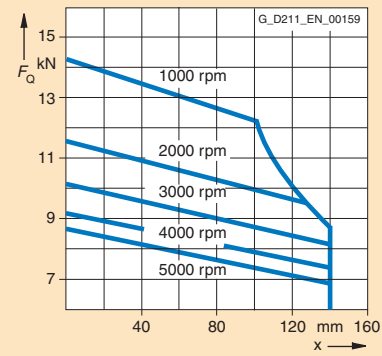
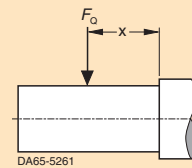

Minimum cantilever force 3 kN

$L_{10h} = 12000 \text{ h}$

The roller bearings used here could sustain damage if they are operated under no load. Observe the specified minimum cantilever forces!

Cantilever force diagrams

Permissible cantilever forces 1PH722 and 1PL622 motors. Shaft height 225 for belt output

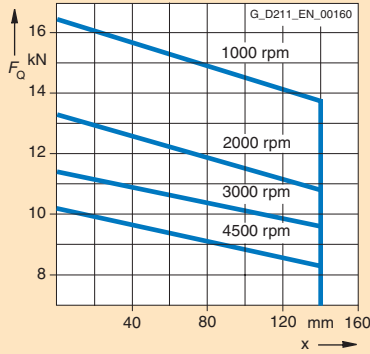
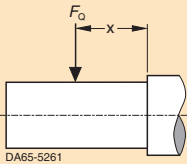

Minimum cantilever force 4 kN $L_{10h} = 12000$ h

Permissible cantilever forces 1PH718 and 1PL618 motors. Shaft height 180 for belt output with incr. cantilever force

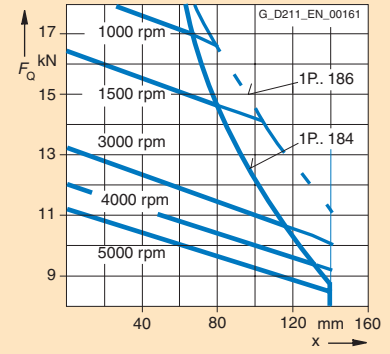
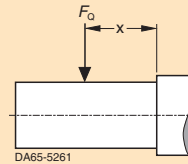

Minimum cantilever force 4 kN $L_{10h} = 12000$ h

Permissible cantilever forces 1PH722 and 1PL622 motors. Shaft height 225 for belt output with incr. cantilever force

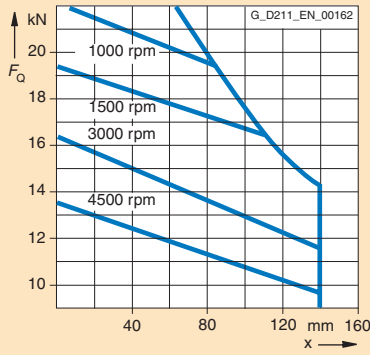
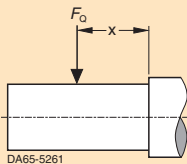

Minimum cantilever force 5 kN $L_{10h} = 12000$ h

Permissible cantilever forces 1PH728 and 1PL628 motors. Shaft height 280 for coupling output

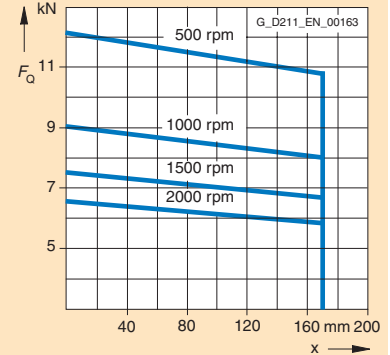
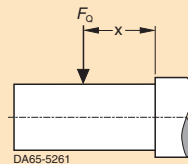

$L_{10h} > 20000$ h when regreased

Permissible cantilever forces 1PH728 and 1PL628 motors. Shaft height 280 for belt output with incr. cantilever force

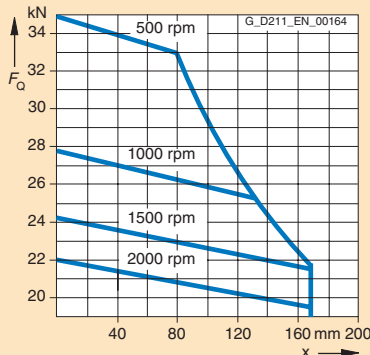
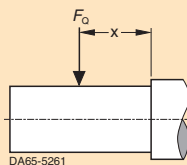

Minimum cantilever force 9 kN $L_{10h} > 12000$ h when regreased

The roller bearings used here could sustain damage if they are operated under no load. Observe the specified minimum cantilever forces!

AC motors

Asynchronous motors

Selection guides for 1PH7 and 1PL6 motors

Mounting position

1PH7 and 1PL6 motors are available in types of construction IM B3 (standard model), IM B5 and IM B35. Other types (IM V15, IM V36, IM B6, IM B7, IM B8 etc.) can also be supplied. Depending on the intended motor mounting position, the motor order (shaft heights 180 and 225) must clearly indicate where the lifting lugs need to be fitted before the motor leaves the factory (12th position in motor order number). In the case of motors of shaft heights 100 to 160, the lifting lug screw fittings can be repositioned later for other hoisting methods.

Note: There are no condensate drain holes in the motors.

3

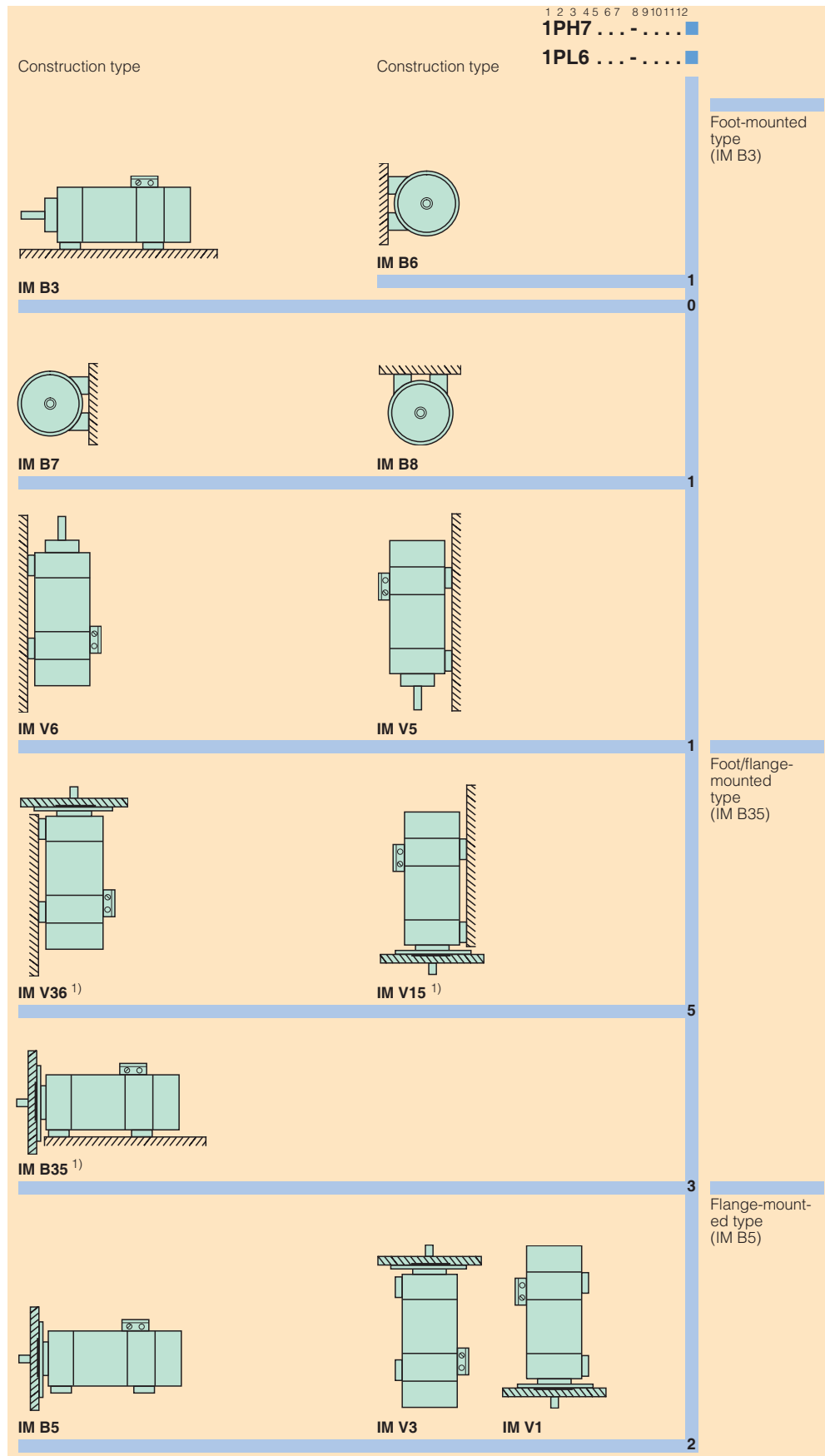

¹⁾ Flange and foot mounting required.

Terminal box assignment, max. connectable cross sections

Shaft height SH	Motor type	Terminal box type	Cable entry	Max. possible outer cable diameter	Cable entry	Max. possible outer cable diameter ²⁾	Number of main terminals	Max. possible cross section per terminal	Max. possible current per terminal ¹⁾
				Valid for the 8th position of order no. "2", "4" or "6" ³⁾	Valid for the 8th position of order no. "7" or "8"	mm ²		A	
1PH7 motors									
100	1PH710-...	Integrated	PG 29	28/1.1	M32 x 1.5	21/0.83	6 x M5	25	84
132	1PH713-...	Integrated	PG 36	34/1.34	M40 x 1.5	28/1.1	6 x M6	35	104
160	1PH716-...	Integrated	PG 42	40/1.57	M50 x 1.5	38/1.5	6 x M6	50	123
180	1PH7184-...	1XB7322	2 x PG 42	40/1.57	2 x M50 x 1.5	38/1.5	3 x M12	2 x 50	191
	1PH7186-... B	1XB7322	2 x PG 42	40/1.57	2 x M50 x 1.5	38/1.5	3 x M12	2 x 50	191
	1PH7186-... D	1XB7322	2 x PG 42	40/1.57	2 x M50 x 1.5	38/1.5	3 x M12	2 x 50	191
	1PH7186-... F	1XB7422	2 x M72 x 2	56/2.2	2 x M63 x 1.5	53/2.09	3 x M12	2 x 70	242
	1PH7186-... L	1XB7422	2 x M72 x 2	56/2.2	2 x M63 x 1.5	53/2.09	3 x M12	2 x 70	242
225	1PH7224-... B	1XB7322	2 x PG 42	40/1.57	2 x M50 x 1.5	38/1.5	3 x M12	2 x 50	191
	1PH7224-... D	1XB7322	2 x PG 42	40/1.57	2 x M50 x 1.5	38/1.5	3 x M12	2 x 50	191
	1PH7224-... U	1XB7422	2 x M72 x 2	56/2.2	2 x M63 x 1.5	53/2.09	3 x M12	2 x 70	242
	1PH7224-... L	1XB7700	3 x M72 x 2	56/2.2	3 x M75 x 1.5	68/2.68	3 x 2 x M12	3 x 150	583
	1PH7226-... B	1XB7322	2 x PG 42	40/1.57	2 x M50 x 1.5	38/1.5	3 x M12	2 x 50	191
	1PH7226-... D	1XB7422	2 x M72 x 2	56/2.2	2 x M63 x 1.5	53/2.09	3 x M12	2 x 70	242
	1PH7226-... F	1XB7700	3 x M72 x 2	56/2.2	3 x M75 x 1.5	68/2.68	3 x 2 x M12	3 x 150	583
	1PH7226-... L	1XB7700	3 x M72 x 2	56/2.2	3 x M75 x 1.5	68/2.68	3 x 2 x M12	3 x 150	583
	1PH7228-... B	1XB7322	2 x PG 42	40/1.57	2 x M50 x 1.5	38/1.5	3 x M12	2 x 50	191
	1PH7228-... D	1XB7700	3 x M72 x 2	56/2.2	3 x M75 x 1.5	68/2.68	3 x 2 x M12	3 x 150	583
	1PH7228-... F	1XB7700	3 x M72 x 2	56/2.2	3 x M75 x 1.5	68/2.68	3 x 2 x M12	3 x 150	583
	1PH7228-... L	1XB7700	3 x M72 x 2	56/2.2	3 x M75 x 1.5	68/2.68	3 x 2 x M12	3 x 150	583
	280	1PH728-... B	1XB7712	3 x M63 x 1.5	53/2.09	-	-	(3+1) ⁴⁾ x 3 x M16	3 x 95
1PH7284-... C									
1PH7284-... D									
1PH7286-... C		1XB7712	3 x M75 x 1.5	68/2.68	-	-	(3+1) ⁴⁾ x 3 x M16	3 x 185/0.287	710
1PH7286-... D									
1PH7288-... C									
1PH7288-... D									
1PH728-... F									

- 1) Current carrying capacity based on IEC 60204-1, routing type C.
- 2) Dependent on the design of the metric cable entry.
- 3) Not for shaft height 280.
- 4) Including grounding terminal.

AC motors

Asynchronous motors

Selection guides for 1PH7 motors Mounted holding brakes

Mounted holding brakes for 1PH7 motors

A brake can be mounted on the drive end of 1PH7 motors with shaft heights 100, 132, 160, 180 and 225.

These brakes are electro-magnetic units for dry-running operation. An electro-magnetic field is used to release the brake which is applied using spring force. It operates according to the closed-circuit principle. When de-energized, the spring-operated brake is applied and holds the drive. When current is flowing, the brake opens and the drive can turn.

When the power fails or an "emergency stop" is issued, the drive is braked from its current speed down to standstill. The holding torques and number of emergency stop operations are shown in the table on page 3/165.

The brakes are intended for connection to alternating voltage 230 V AC, 50 to 60 Hz or to direct voltage 24 V DC (only up to frame size 160), which must be provided by the customer.

The rectifier is built into the terminal box of the brake. The degree of protection is IP55.

In the basic version, the brake has three emergency release screws (only for shaft heights 180 and 225); these are axially accessible from the front. The integrated or built-on microswitch can be incorporated in a higher-level control system as either an NC or an NO contact. The fast switching rectifier is used to over-excite the coil to release the brake and to achieve short release times (release current = 2 x holding current).

All of the relevant technical data - e.g. holding torque, permissible speeds, number of emergency braking operations and brake currents are listed in the table on page 3/165.

The operating instructions for the built-on holding brake are supplied together with the motor-brake unit.

Ordering example: 1PH7 186-2HF00-2AA3

Construction type IM B3, holding brake includes microswitch and emergency-release screw (see also order number code on page 3/165 for further ordering options).

Built-on holding brake for motors, shaft heights 100 to 160

The holding brakes for motors in shaft heights 100, 132, and 160 are brake modules (manufactured by Binder) with their own bearings, flange and shaft extension. The brake module's flange and shaft end dimensions are identical to those of the motor. If a motor is to be fitted with a brake, the motor is made in flange-design and with a plain shaft (without a fitted key). The brake module's shaft is then fitted onto the motor shaft by heat shrinking. It can be removed by using an oil-hydraulic interference fit. The brake module is then screwed onto the motor flange. The brake module's shaft end contains a fitted key (with half-key balancing).

The output can be implemented with either a coupling or belt pulley. The permissible cantilever forces can be found in the appropriate cantilever force diagrams.

1PH7 motors (shaft heights 100, 132) are available with type of construction IM B5; further, motors in shaft heights 100, 132 and 160 are also available with type of construction IM B35 (it is also possible to provide motors with a foot mounting type of construction IM B3).

If required, a manual release can be mounted on the brake, so that the brake can be released manually in the event of a voltage failure or motor shutdown. When the manual release lever is released, it automatically returns to the braking state. It is also possible to install a microswitch, which can then be integrated into a higher-level control system as either an NC or NO contact. The microswitch is connected via a separate cable.

The brake module has degree of protection IP55. Motors with built-on brake modules are only available in the vibration severity grade N, and with the shaft and flange accuracy N.

All of the relevant technical data, e.g. holding torque, max. braking energy, permissible speeds, cantilever forces and brake currents are listed in the table on page 3/165.

Ordering example: 1PH7 137-2HF02-3KB3

Construction type IM B5, holding brake with manual release (see also order number code on page 3/165 for further ordering options).

Built-on holding brake for 1PH7 motors, shaft heights 180 and 225

For these motors, the brake (manufactured by Stromag) is mounted on the DE bearing endshield. The motor shaft is extended using a shrunk-on stub shaft. The torque is transmitted through a fitted key in accordance with DIN 6885/1. The stub shaft can in addition be axially secured using a thrust washer and a central screw (M20). The holding brake does not have its own bearings; the output forces are therefore absorbed by the motor bearings. Due to limitations of space and their high transverse forces, belt pulleys cannot be attached. When selecting the coupling to couple to the motor-brake combination, it should be carefully noted that the shaft end diameter is larger than the diameter of the motor shaft end. REVOLLEX bolt-type couplings 2LF6337 for shaft height 180 and 2LF6338 for shaft height 225 can be used if preferred.

Ordering data and dimensions, refer to Catalog D 81.1.

Mounted holding brakes for 1PH7 motors (continued)

Technical data of built-on holding brakes with emergency stop function (brake supply voltage 230 V AC, 50 ... 60 Hz/DC 24 V +5% -10%)

Shaft height	Motor type	Brake type	Holding torque	Speed	Perm. single switching energy	Service life switching energy	No. emergency stops before lining change from z	Coil current	Flange dimension	Shaft extension dimension	Perm. cantilever force	Moment of inertia of brake	Weight of brake	Opening time	Closing time			
			(tolerance ±20%)	n_{max}	W_E	W_{max}	n_{max} at J	AC DC	DIN 42 948	DIN 748	(3000 rpm, x_{max})	of brake	ms	ms				
			Nm/lb _f -ft	rpm	kJ	MJ	-	A	A	mm/ in	mm/ in	N/ lb _f	kgm ² / lb _f -in-s ²	kg/lb	ms	ms		
For 1PH7 motors with brake supply voltage 230 V AC, 50 ... 60 Hz																		
100	1PH710 . Size 19		60 ... 150/ 44.2 ... 110.6	5500	25	90	8700	0.062/ 0.549	1.0	4.7	A250	38/ 1.5	80/ 3.15	2300/ 517.06	0.005/ 0.044	21/ 46.31	255	60
132	1PH713 . Size 24		140 ... 310/ 103.2 ... 228.5	4500	40	226	9400	0.208/ 1.841	1.3	6.3	A350	42/ 1.65	110/ 4.33	2000/ 449.62	0.015/ 0.133	46/ 101.43	330	95
160	1PH716 . Size 29		280 ... 500/ 206.4 ... 368.5	3700	60	401	11900	0.448/ 3.965	1.35	6.7	A400	55/ 2.17	110/ 4.33	6800/ 1528.71	0.028/ 0.248	66/ 145.53	350	450
180	1PH7184 NFE 60		600/442.2	3500	69	154	2230	1.02/ 9.028	0.9	-	-	90/ 3.54	90/ 3.54	2800/ 629.47	0.027/ 0.239	55/ 121.28	400	160
	1PH7186 NFE 60/80		800/589.6		91	56	620	1.36/ 12.037							0.026/ 0.23			
225	1PH7224 NFE 100		1000/737	3100	158	153	970	3.0/ 26.552	1.3	-	-	100/ 3.94	100/ 3.94	2800/ 629.47	0.041/ 0.363	75/ 165.38	460	200
	1PH7226 NFE 100		1000/737		206	109	530	3.9/ 34.518							0.041/ 0.363			
	1PH7228 NFE 100/140		1400/1031.8		248	32	130	4.7/ 41.598							0.041/ 0.363			

Holding torque in Nm (lb_f-ft): For motors in shaft heights 100 to 160, the holding torque can be continuously set in the specified value range using a setting ring. The dynamic braking torque is approximately 0.7 to 0.8 x holding torque.

Speed n_{max} : Max. permissible speed at which emergency stops are possible.

Perm. single switching energy W_E in kJ: Perm. switching energy during an emergency stop, $W_E = J_{total} \times n^2 / 182.5 \times 10^{-3}$ (J in kgm²(lb_f-in-s²), n in rpm)

Service life switching energy W_{max} in MJ: Max. possible switching energy of the brake (for emergency stop) until the brake linings must be replaced, $W_{max} = W_E \times z$.

No. of emergency stops z: The specified no. of emergency stops refers to the following conditions: Braking from speed n_{max} , $J_{total} = 2 \times J_{mot}$.

A conversion can be made for operation under different conditions:

Number of emergency stops $z = W_{max} / W_E$

Coil current in A: Current in order to maintain the brake in a released condition. The following applies for NFE brakes:

Release current = 2 x holding current.

Perm. cantilever force in N (lb_f): For motors in shaft heights 100 to 160, coupling and belt outputs are possible; for shaft heights 180 and 225, only coupling outputs are permissible.

Opening (release) time in ms: Separating time until the brake opens (the specified values refer to the max. braking torque).

Closing time in ms: Interlocking time until the brake closes (the values refer to the max. braking torque).

Order No. code for 1PH7 shaft heights 100, 132 and 160 for a built-on holding brake with emergency stop function

	1	2	3	4	5	6	7	8	9	10	11	12	13	14	15	16
No brake																
Brake supply voltage: 230 V AC, 50 – 60 Hz																
With brake (brake supply voltage: 230 V AC, 50–60 Hz)																
With brake (brake has microswitch)																
With brake (brake has manual release function)																
With brake (brake has a microswitch and manual release)																
Brake supply voltage: 24 V DC																
With brake (brake supply voltage: 24 V DC)																
With brake (brake has microswitch)																
With brake (brake has manual release function)																
With brake (brake has a microswitch and manual release)																

Brake versions are only possible in the following combination:

- Vibration severity grade N, shaft and flange accuracy N ("K" in 14th position)
- Shaft extension on the brake module with fitted key and half-key balancing (an "A" or "B" at the 15th pos.) or plain shaft end (a "J" or "K" at the 15th pos.)
- Type of construction IM B 5 (only for sizes 100 and 132, a "2" at the 12th position) or IM B 35 (a "3" at the 12th position, can be mounted/installed with foot type of construction IM B 3) and at the 16th position "0", "3" or "6".

Order No. code for 1PH7 shaft heights 180 and 225 for a built-on holding brake with emergency stop function

	1	2	3	4	5	6	7	8	9	10	11	12	13	14	15	16
No brake																
With brake (brake has a microswitch and emergency release screw)																
With brake (brake has a microswitch and manual release)																

Versions 2 and 4 are only available in type of construction IM B 3, i.e.:

- at the 12th position, only "0"
- at the 14th position, only "A"
- at the 15th position, only "A"
- and at the 16th position only "0", "3" or "6".

AC motors

Asynchronous motors

Selection guides for 1PL6 motors

Terminal box assignments/cable cross sections

Terminal box assignment, max. connectable cross sections

Shaft height SH	Motor type	Terminal box type	Cable entry	Max. possible outer cable diameter	Cable entry	Max. possible outer cable diameter ²⁾	Number of main terminals	Max. possible cross section per terminal	Max. possible current per terminal ¹⁾	
				Valid for the 8th position of order no. "2", "4" or "6" ³⁾		Valid for the 8th position of order no. "7" or "8"		mm ²	A	
				mm/in		mm/in				
1PL6 motors										
180	1PL6184-...B	1XB7322	2 x PG 42	40/1.57	2 x M50 x 1.5	38/1.5	3 x M12	2 x 50	191	
	1PL6184-...D	1XB7322	2 x PG 42	40/1.57	2 x M50 x 1.5	38/1.5	3 x M12	2 x 50	191	
	1PL6184-...F	1XB7322	2 x PG 42	40/1.57	2 x M50 x 1.5	38/1.5	3 x M12	2 x 50	191	
	1PL6184-...L	1XB7422	2 x M72 x 2	56/2.2	2 x M63 x 1.5	53/2.09	3 x M12	2 x 70	242	
	1PL6186-...B	1XB7322	2 x PG 42	40/1.57	2 x M50 x 1.5	38/1.5	3 x M12	2 x 50	191	
	1PL6186-...D	1XB7322	2 x PG 42	40/1.57	2 x M50 x 1.5	38/1.5	3 x M12	2 x 50	191	
	1PL6186-...F	1XB7422	2 x M72 x 2	56/2.2	2 x M63 x 1.5	53/2.09	3 x M12	2 x 70	242	
	1PL6186-...L	1XB7700	3 x M72 x 2	56/2.2	3 x M75 x 1.5	68/2.68	3 x 2 x M12	3 x 150	583	
225	1PL6224-...B	1XB7322	2 x PG 42	40/1.57	2 x M50 x 1.5	38/1.5	3 x M12	2 x 50	191	
	1PL6224-...D	1XB7422	2 x M72 x 2	56/2.2	2 x M63 x 1.5	53/2.09	3 x M12	2 x 70	242	
	1PL6224-...F	1XB7700	3 x M72 x 2	56/2.2	3 x M75 x 1.5	68/2.68	3 x 2 x M12	3 x 150	583	
	1PL6224-...L	1XB7700	3 x M72 x 2	56/2.2	3 x M75 x 1.5	68/2.68	3 x 2 x M12	3 x 150	583	
	1PL6226-...B	1XB7322	2 x PG 42	40/1.57	2 x M50 x 1.5	38/1.5	3 x M12	2 x 50	191	
	1PL6226-...D	1XB7700	3 x M72 x 2	56/2.2	3 x M75 x 1.5	68/2.68	3 x 2 x M12	3 x 150	583	
	1PL6226-...F	1XB7700	3 x M72 x 2	56/2.2	3 x M75 x 1.5	68/2.68	3 x 2 x M12	3 x 150	583	
	1PL6226-...L	1XB7700	3 x M72 x 2	56/2.2	3 x M75 x 1.5	68/2.68	3 x 2 x M12	3 x 150	583	
	1PL6228-...B	1XB7322	2 x PG 42	40/1.57	2 x M50 x 1.5	38/1.5	3 x M12	2 x 50	191	
	1PL6228-...D	1XB7700	3 x M72 x 2	56/2.2	3 x M75 x 1.5	68/2.68	3 x 2 x M12	3 x 150	583	
	1PL6228-...F	1XB7700	3 x M72 x 2	56/2.2	3 x M75 x 1.5	68/2.68	3 x 2 x M12	3 x 150	583	
	1PL6228-...L	1XB7700	3 x M72 x 2	56/2.2	3 x M75 x 1.5	68/2.68	3 x 2 x M12	3 x 150	583	
280	1PL628-...	1XB7712	4 x M75 x 1.5	68/2.68	-	-	(3+1) ⁴⁾ x 4 x M16	4 x 185	925	

3



1PH4 AC motors, shaft heights 100 to 160

The AC motors in the 1PH4 series are compact, water-cooled squirrel-cage asynchronous motors with a high degree of protection.

They have been designed specifically for use in conjunction with the SINAMICS S120 drive system, allowing power losses and noise levels to be reduced to a minimum. Depending on the control requirements, the appropriate encoder systems are available for the motors. These encoders are used to sense the motor speed and indirect position.

Benefits

- High power density with small motor dimensions
- High degree of protection (IP65, shaft exit IP55)
- Speed down to zero without reducing the torque
- Low noise level
- High cantilever force loading
- Robustness
- Essentially maintenance-free
- High rotational accuracy
- Integrated encoder system to sense the motor speed, connected using a connector
- Terminal box to connect up power cables
- Motor temperature monitoring with KTY 84
- Maximum permissible water pressure 6 bar

Applications

- All applications in which extreme ambient conditions, such as dust, dirt, or a corrosive atmosphere, do not permit air cooling
- In processes in which the environment must not be heated
- On special machines, when cooling water is an inherent process element

AC motors

Asynchronous motors

1PH4 motors

Water cooling

Technical data

Insulation of the stator winding to EN 60034-1 (IEC 60034-1)	Thermal Class F for a coolant inlet temperature of +30 °C (86 °F)
Construction type according to EN 60034-7 (IEC 60034-7)	IM B35 (IM V15, IM V36)
Degree of protection according to EN 60034-5 (IEC 60034-5)	IP65 (IP55 on shaft exit)
Cooling according to EN 60034-6 (IEC 60034-6)	Water cooling Due to the possible formation of condensation, we recommend a coolant inlet temperature of approximately +30 °C (86 °F). Max. cooling water pressure at inlet: 6 bar Cooling water quantity/connecting thread at NDE: 1PH410: 6 l/min/G ¼ 1PH413: 8 l/min/G 3/8 1PH416: 10 l/min/G ½
Temperature monitoring	KTY 84 temperature sensor in stator winding
Paint finish	Anthracite RAL 7016
Shaft extension on the drive end to DIN 748-3 (IEC 60072-1)	With fitted key, full-key balancing
Shaft and flange accuracy according to DIN 42955 (IEC 60072-1)	Tolerance N (normal)
Vibration severity grade acc. to EN 60034-14 (IEC 60034-14)	Grade R (reduced)
Sound pressure level acc. to DIN EN ISO 1680 tolerance +3 dB	1PH410: 69 dB (A) 1PH413: 69 dB (A) 1PH416: 71 dB (A)
Bearing designs	Duplex bearing at DE for belt output (minimum cantilever force required)
Encoder system, integrated	<ul style="list-style-type: none"> • Incremental encoder HTL 1024 pulses/revolution or 2048 pulses/revolution • Incremental encoder sin/cos 1 V_{pp}, 2048 pulses/revolution • Absolute encoder EnDat 2048 pulses/revolution
Connection	Connector for signals (mating connector not supplied) Terminal box for power; terminal box at top (can be rotated 4 x 90°)
Options	Refer to Options and Selection and ordering data

Characteristics

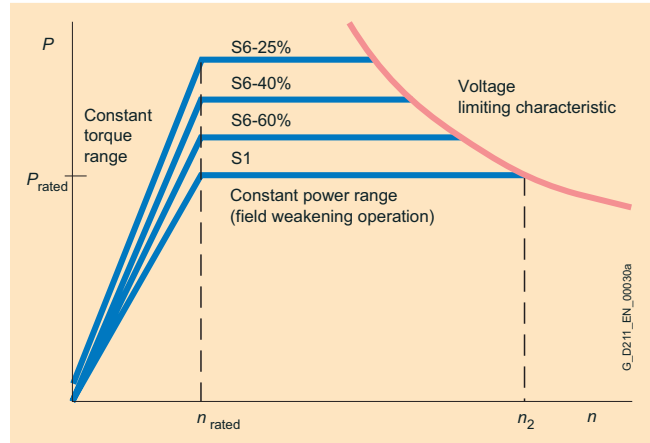

Speed characteristic

Options

Order code	Option description
K00	Bearing arrangement (view onto DE) (default = duplex bearing) <ul style="list-style-type: none"> • Single bearing <ul style="list-style-type: none"> - for coupling ¹⁾ - Planetary gearboxes (e.g. ZF gear-change gearbox 2LG43..., construction types IM B35, IM V15 ¹⁾²⁾) - for low to moderate cantilever forces
K05 K02 K03	Vibration severity in accordance with EN 60034-14 (IEC 60034-14) (standard = vibration severity grade R, duplex bearing) <ul style="list-style-type: none"> - Grade S with duplex bearing arrangement ³⁾ - Grade S with single bearing arrangement ³⁾ - Grade SR with single bearing ³⁾
K04	Shaft and flange accuracy in accordance with DIN 42955 (IEC 60072-1) (standard = tolerance N) <ul style="list-style-type: none"> - Tolerance R ⁴⁾
K42 L69	Shaft extension (DE) (standard = full-key balancing with keyway) <ul style="list-style-type: none"> - Plain shaft - Half-key balancing
K18	Shaft seal (DE) ⁵⁾ - Rotary shaft seal, oil-tight, IP65
G46	Brake ¹⁾ - With holding brake mounted on DE
K09 K10	Terminal box arrangement (view onto DE) (standard = top) <ul style="list-style-type: none"> - Right-hand side - Left-hand side
K83 K84 K85	Terminal box rotation <ul style="list-style-type: none"> - by 90°, cable entry from drive end - by 90°, cable entry from non-drive end - by 180°
L37	Speed ⁶⁾ - Increased maximum speed and half-key balancing
K31	Rating plate - Second rating plate, separately packed
H30	Encoder system - Without encoder

¹⁾ Options mutually exclude each other.

²⁾ Vibration severity grades S/SR are not available for models with built-on gearboxes. Use order code **K00 + G97** for ZF gear unit 2LG42... (for gear selection, see "Gearboxes").

³⁾ Automatically includes version **K04**.

⁴⁾ Increased shaft accuracy.

⁵⁾ Only recommended if the sealing ring is occasionally lubricated with oil spray or mist.

⁶⁾ Version for increased maximum speed includes vibration severity grade SR and half-key balancing. The following options are not possible:

- Prepared for ZF gearbox mounting
- Shaft seal.

AC motors

Asynchronous motors

1PH4 motors Water cooling

Selection and ordering data

Rated speed	Shaft height SH	Rated power	Rated torque	Rated current	Rated voltage	Speed during field weakening ¹⁾	Max. permissible continuous speed ²⁾	Max. speed ³⁾	1PH4 asynchronous motor ⁴⁾
n_{rated} rpm		P_{rated} kW/HP	M_{rated} Nm/lb-ft	I_{rated} A	V_{rated} V	n_2 rpm	n_{S1} rpm	n_{max} rpm	Order No.
400 V 3 AC line voltage, Servo Control									
1500	100	7.5/10.1	48/35.4	20.5	350	3200	5600	7500 ⁶⁾	1PH4103-4 ■ F 5 6
		11/14.8	70/51.6	28	350	2900	5600	7500 ⁶⁾	1PH4105-4 ■ F 5 6
		14/18.8	89/65.6	35.5	350	3150	5600	7500 ⁶⁾	1PH4107-4 ■ F 5 6
	132	15/20.1	95/70	35	350	2200	5200	6700	1PH4133-4 ■ F 5 6
		22/29.5	140/103.2	52	350	2600	5200	6700	1PH4135-4 ■ F 5 6
		27/36.2	172/126.8	62	350	2450	5200	6700	1PH4137-4 ■ F 5 6
	160	37/49.6	236/173.9	89	350	3000	4000	5300	1PH4163-4 ■ F 5 6
		46/61.7	293/215.9	107	350	2850	4000	5300	1PH4167-4 ■ F 5 6
		52/69.7	331/243.9	117	350	2700	4000	5300	1PH4168-4 ■ F 5 6

Encoder systems for motors without DRIVE-CLiQ interface:

Absolute encoder EnDat 2048 pulses/revolution
 Incremental encoder HTL 1024 pulses/revolution
 Incremental encoder HTL 2048 pulses/revolution
 Incremental encoder sin/cos 1 V_{pp} with C and D tracks
 Incremental encoder sin/cos 1 V_{pp} without C and D tracks

E
H
J
M
N

Encoder systems for motors with DRIVE-CLiQ interface:

Absolute encoder EnDat 2048 pulses/revolution
 Incremental encoder sin/cos 1 V_{pp} with C and D tracks
 Incremental encoder sin/cos 1 V_{pp} without C and D tracks

F
D
Q

Selection and ordering data

Power factor $\cos \varphi$	Magnetizing current I_{μ} A	Efficiency η_{rated}	Rated frequency f_{rated} Hz	Moment of inertia of J kgm ² / lb _r -in-s ²	Weight, approx. kg/lb	1PH4 asynchronous motor ⁴⁾	SINAMICS S120 Motor Module Rated output current		
						Order No.	I_{rated} A	Order No.	
400 V 3 AC line voltage, Servo Control									
0.74	12	0.820	52.8	0.017/0.15	52/114.66	1PH4103-4 . F 5 6	18 ⁵⁾	6SL3120-1 T E21-8AA 1	
0.78	13.5	0.836	52.9	0.024/0.212	67/147.74	1PH4105-4 . F 5 6	30	6SL3120-1 T E23-0AA 1	
0.77	18.5	0.851	52.5	0.031/0.274	80/176.4	1PH4107-4 . F 5 6	45	6SL3120-1 T E24-5AA 1	
0.81	13	0.877	51.8	0.046/0.407	90/198.45	1PH4133-4 . F 5 6	45	6SL3120-1 T E24-5AA 1	
0.79	24	0.890	51.4	0.071/0.628	112/246.96	1PH4135-4 . F 5 6	60	6SL3120-1 T E26-0AA 1	
0.81	24	0.895	51.5	0.085/0.752	130/286.65	1PH4137-4 . F 5 6	60 ⁵⁾	6SL3120-1 T E26-0AA 1	
0.77	45	0.905	50.9	0.10/1.505	175/385.88	1PH4163-4 . F 5 6	85 ⁵⁾	6SL3120-1 T E28-5AA 1	
0.79	48	0.910	51.0	0.206/1.823	210/463.05	1PH4167-4 . F 5 6	132	6SL3120-1 T E31-3AA 0	
0.81	48	0.913	51.0	0.220/1.947	240/529.2	1PH4168-4 . F 5 6	132	6SL3120-1 T E31-3AA 0	
Special versions:		Specify supplementary order code and plain text if applicable (see Options).					-Z		
Motor Module:		Single Motor Module						1	
		Double Motor Module						2	1 0

1) n_2 : Max. permissible thermal speed at constant output or speed, which is at the voltage limit when $P = P_{\text{rated}}$.

2) n_{S1} : Max. permissible speed that is continuously permitted without speed duty cycles.

3) n_{max} : Maximum speed which must not be exceeded.

4) Standard design with duplex bearing.

5) The rated output current of the Motor Module is lower than the motor rated current.

6) Speed is limited to lower values in some cases. The following restriction applies: Max. output frequency < 5 × motor rated frequency.

AC motors

Asynchronous motors

1PH4 motors Water cooling

Selection and ordering data

Rated speed	Shaft height SH	Rated power	Rated torque	Rated current	Rated voltage	Speed during field weakening ¹⁾	Max. permissible continuous speed ²⁾	Max. speed ³⁾	1PH4 asynchronous motor ⁴⁾
n_{rated} rpm		P_{rated} kW/HP	M_{rated} Nm/lb _f -ft	I_{rated} A	V_{rated} V	n_2 rpm	n_{S1} rpm	n_{max} rpm	Order No.
400 V 3 AC line voltage, Vector Control									
1750	100	8.8/11.8	48/35.4	20.5	400	3750	5600	7500 ⁶⁾	1PH4103-4 ■ F 5 6
		12.8/17.2	70/51.6	28	400	3450	5600	7500 ⁶⁾	1PH4105-4 ■ F 5 6
		16.3/21.9	89/65.6	35.5	400	3700	5600	7500 ⁶⁾	1PH4107-4 ■ F 5 6
	132	17.5/23.5	96/70.8	35.5	400	2550	5200	6700	1PH4133-4 ■ F 5 6
		25.5/34.2	139/102.4	52	400	3000	5200	6700	1PH4135-4 ■ F 5 6
		31.5/42.2	172/126.8	63	400	2800	5200	6700	1PH4137-4 ■ F 5 6
	160	43/57.7	235/173.2	88	400	3400	4000	5300	1PH4163-4 ■ F 5 6
		54/72.4	295/217.4	107	400	3200	4000	5300	1PH4167-4 ■ F 5 6
		61/81.8	333/245.4	117	400	3050	4000	5300	1PH4168-4 ■ F 5 6

Encoder systems for motors without DRIVE-CLiQ interface:

Absolute encoder EnDat 2048 pulses/revolution
 Incremental encoder HTL 1024 pulses/revolution
 Incremental encoder HTL 2048 pulses/revolution
 Incremental encoder sin/cos 1 V_{pp} with C and D tracks
 Incremental encoder sin/cos 1 V_{pp} without C and D tracks

**E
H
J
M
N**

Encoder systems for motors with DRIVE-CLiQ interface:

Absolute encoder EnDat 2048 pulses/revolution
 Incremental encoder sin/cos 1 V_{pp} with C and D tracks
 Incremental encoder sin/cos 1 V_{pp} without C and D tracks

**F
D
Q**

Selection and ordering data

Power factor $\cos \varphi$	Magnetizing current I_{μ} A	Efficiency η_{rated}	Rated frequency f_{rated} Hz	Moment of inertia of J kgm ² / lb _f -in ² -s ²	Weight, approx. kg/lb	1PH4 asynchronous motor 1PH4 ⁴⁾	SINAMICS S120 Motor Module Rated output current		
						Order No.	I_{rated} A	Order No.	
400 V 3 AC line voltage, Vector Control									
0.75	11.5	0.841	61.2	0.017/0.15	52/114.66	1PH4103-4 . F 5 6	18 ⁵⁾	6SL3120-1 TE21-8AA	
0.78	13.5	0.854	61.3	0.024/0.212	67/147.74	1PH4105-4 . F 5 6	30	6SL3120-1 TE23-0AA 1	
0.78	18	0.867	61.0	0.031/0.274	80/176.4	1PH4107-4 . F 5 6	45	6SL3120-1 TE24-5AA 1	
0.82	12	0.887	60.2	0.046/0.407	90/198.45	1PH4133-4 . F 5 6	45	6SL3120-1 TE24-5AA 1	
0.79	22	0.901	59.8	0.071/0.628	112/246.96	1PH4135-4 . F 5 6	60	6SL3120-1 TE26-0AA 1	
0.81	23	0.905	59.9	0.085/0.752	130/286.65	1PH4137-4 . F 5 6	60 ⁵⁾	6SL3120-1 TE26-0AA 1	
0.78	42	0.914	59.3	0.170/1.505	175/385.88	1PH4163-4 . F 5 6	85 ⁵⁾	6SL3120-1 TE28-5AA 1	
0.80	44	0.920	59.4	0.206/1.823	210/463.05	1PH4167-4 . F 5 6	132	6SL3120-1 TE31-3AA 0	
0.82	43	0.921	59.4	0.220/1.947	240/529.2	1PH4168-4 . F 5 6	132	6SL3120-1 TE31-3AA 0	
Special versions:		Specify supplementary order code and plain text if applicable (see Options).					-Z		
Motor Module:		Single Motor Module Double Motor Module						1 2	1 0

- n_2 : Max. permissible thermal speed at constant output or speed, which is at the voltage limit when $P = P_{\text{rated}}$.
- n_{S1} : Max. permissible speed that is continuously permitted without speed duty cycles.
- n_{max} : Maximum speed which must not be exceeded.

- Standard design with duplex bearing.
- The rated output current of the Motor Module is lower than the motor rated current.
- Speed is limited to lower values in some cases. The following restriction applies: Max. output frequency < 5 × motor rated frequency.

AC motors

Asynchronous motors

1PH4 motors Water cooling

Selection and ordering data

Rated speed	Shaft height SH	Rated power	Rated torque	Rated current	Rated voltage	Speed during field weakening ¹⁾	Max. permissible continuous speed ²⁾	Max. speed ³⁾	1PH4 asynchronous motor ⁴⁾
n_{rated} rpm		P_{rated} kW/HP	M_{rated} Nm/lb _f -ft	I_{rated} A	V_{rated} V	n_2 rpm	n_{S1} rpm	n_{max} rpm	Order No.
480 V 3 AC line voltage, Servo/Vector Control									
2000	100	9.5/12.7	45/33.2	19.5	450	4850	5600	7500 ⁶⁾	1PH4103-4 ■ F 5 6
		14/18.8	67/49.4	26.5	450	4450	5600	7500 ⁶⁾	1PH4105-4 ■ F 5 6
		18/24.1	86/63.4	34.5	450	4700	5600	7500 ⁶⁾	1PH4107-4 ■ F 5 6
	132	19/25.5	91/67.1	33.5	450	3300	5200	6700	1PH4133-4 ■ F 5 6
		28/37.6	134/98.8	50	450	3720	5200	6700	1PH4135-4 ■ F 5 6
		34/45.6	162/119.4	59	450	3600	5200	6700	1PH4137-4 ■ F 5 6
	160	47/63.0	224/165.1	84	450	4300	4000	5300	1PH4163-4 ■ F 5 6
		58/77.8	277/204.1	101	450	3980	4000	5300	1PH4167-4 ■ F 5 6
		65/87.2	310/228.5	110	450	3750	4000	5300	1PH4168-4 ■ F 5 6

Encoder systems for motors without DRIVE-CLiQ interface:

Absolute encoder EnDat 2048 pulses/revolution
 Incremental encoder HTL 1024 pulses/revolution
 Incremental encoder HTL 2048 pulses/revolution
 Incremental encoder sin/cos 1 V_{pp} with C and D tracks
 Incremental encoder sin/cos 1 V_{pp} without C and D tracks

**E
H
J
M
N**

Encoder systems for motors with DRIVE-CLiQ interface:

Absolute encoder EnDat 2048 pulses/revolution
 Incremental encoder sin/cos 1 V_{pp} with C and D tracks
 Incremental encoder sin/cos 1 V_{pp} without C and D tracks

**F
D
Q**

Selection and ordering data

Power factor	Magnetizing current I_{μ} A	Efficiency η_{rated}	Rated frequency f_{rated} Hz	Moment of inertia of J kgm ² /lb _r -in-s ²	Weight, approx. kg/lb	1PH4 asynchronous motor 1PH4 ⁴⁾	SINAMICS S120 Motor Module Rated output current		
						Order No.	I_{rated} A	Order No.	
480 V 3 AC line voltage, Servo/Vector Control									
0.74	11.2	0.856	69.3	0.017/0.15	52/114.66	1PH4 103- 4 . F 5 6	18 ⁵⁾	6SL3120-1 TE21-8AA 1	
0.79	12.9	0.870	69.4	0.024/0.212	67/147.74	1PH4 105- 4 . F 5 6	30	6SL3120-1 TE23-0AA 1	
0.78	17.1	0.879	69.1	0.031/0.274	80/176.4	1PH4 107- 4 . F 5 6	45	6SL3120-1 TE24-5AA 1	
0.83	11.9	0.899	68.4	0.046/0.407	90/198.45	1PH4 133- 4 . F 5 6	45	6SL3120-1 TE24-5AA 1	
0.80	21.5	0.909	68.1	0.071/0.628	112/246.96	1PH4 135- 4 . F 5 6	60	6SL3120-1 TE26-0AA 1	
0.83	22.1	0.914	68.1	0.085/0.752	130/286.65	1PH4 137- 4 . F 5 6	60	6SL3120-1 TE26-0AA 1	
0.79	39.7	0.923	67.6	0.170/1.505	175/385.88	1PH4 163- 4 . F 5 6	85	6SL3120-1 TE28-5AA 1	
0.81	42.6	0.926	67.6	0.206/1.823	210/463.05	1PH4 167- 4 . F 5 6	132	6SL3120-1 TE31-3AA 0	
0.83	41	0.928	67.6	0.220/1.947	240/529.2	1PH4 168- 4 . F 5 6	132	6SL3120-1 TE31-3AA 0	
Special versions:		Specify supplementary order code and plain text if applicable (see Options).					-Z		
Motor Module:		Single Motor Module Double Motor Module						1 2	1 0

1) n_2 : Max. permissible thermal speed at constant output or speed, which is at the voltage limit when $P = P_{\text{rated}}$.

2) n_{S1} : Max. permissible speed that is continuously permitted without speed duty cycles.

3) n_{max} : Maximum speed which must not be exceeded.

4) Standard design with duplex bearing.

5) The rated output current of the Motor Module is lower than the motor rated current.

6) Speed is limited to lower values in some cases. The following restriction applies: Max. output frequency < 5 × motor rated frequency.

AC motors

Dimension drawings - synchronous motors

1FT6 motors with/without DRIVE-CLiQ Natural cooling

For motor		Dimensions in mm (in)													Resolver without brake		with brake	
Shaft height	Type	DIN IEC	a ₁ P	b ₁ N	c ₁ LA	e ₁ M	f AB	f ₁ T	without DRIVE-CLiQ	with DRIVE-CLiQ	h H	i ₂ -	s ₂ S	o ₁	k	o	k	o
									g ₂ -	g ₂ -					LB	-	LB	-
1FT6, type IM B5, natural cooling, with connector, with/without brake																		
28	1FT6021	-	40 (1.57)	9.8 (0.39)	63 (2.48)	55 (2.17)	2.5 (0.10)	64 (2.52)	73.5 (2.89)	28 (1.10)	20 (0.79)	5.8 (0.23)	34.5 (1.36)	193 (7.60)	122 (4.80)	218 (8.58)	147 (5.79)	
	1FT6024													233 (9.17)	162 (6.38)	258 (10.16)	187 (7.36)	
36	1FT6031	92 (3.62)	60 (2.36)	8 (0.31)	75 (2.95)	72 (2.83)	3 (0.12)	76 (2.99)	86 (3.39)	36 (1.42)	30 (1.18)	5.5 (0.22)	-	180 (7.09)	151 (5.94)	200 (7.87)	171 (6.73)	
	1FT6034													220 (8.66)	191 (7.52)	240 (9.45)	211 (8.31)	

Shaft height	Type	DIN IEC	Incremental encoder sin/cos 1 V _{pp} Absolute encoder (EnDat)				DE shaft extension				
			k LB	o -	k LB	o -	d D	d ₆ -	l E	t GA	u F
28	1FT6021		193 (7.60)	122 (4.80)	218 (8.58)	147 (5.79)	9 (0.35)	M8	20 (0.79)	10.2 (0.40)	3 (0.12)
	1FT6024		233 (9.17)	162 (6.38)	258 (10.16)	187 (7.36)					
36	1FT6031		220 (8.66)	151 (5.94)	240 (9.45)	171 (6.73)	14 (0.55)	M5	30 (1.18)	16 (0.63)	5 (0.2)
	1FT6034		260 (10.24)	191 (7.52)	280 (11.02)	211 (8.31)					

1FT602 .

Shaft design
with fitted key

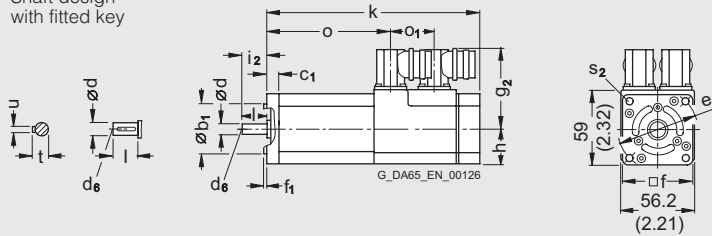

1FT603 .

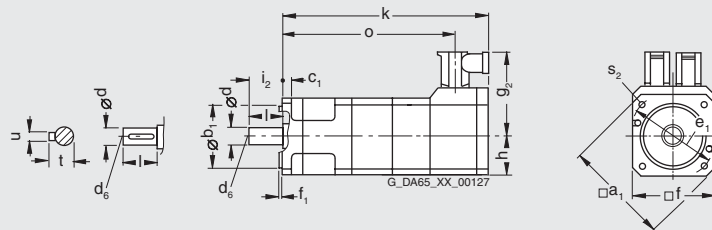

AC motors

Dimension drawings - synchronous motors

1FT6 motors with/without DRIVE-CLiQ Natural cooling

Shaft height	Type	DIN IEC	Dimensions in mm (in)											Resolver				
			a ₁ P	b ₁ N	c ₁ LA	e ₁ M	f AB	f ₁ T	g ₂ -	g ₂ -	h H	i ₂ -	s ₂ ¹⁾ S	s ₂ ²⁾ S	k LB	o -	k LB	o -
1FT6, type IM B5, natural cooling, with connector, with/without brake																		
48	1FT6041		120 (4.72)	80 (3.15)	10 (0.39)	100 (3.94)	96 (3.78)	3 (0.12)	80 (3.15)	90 (3.54)	48 (1.89)	40 (1.57)	7 (0.28)	M6	185 (7.28)	159 (6.26)	220 (8.66)	194 (7.64)
	1FT6044														235 (9.25)	209 (8.23)	270 (10.63)	244 (9.61)
63	1FT6061		146 (5.75)	110 (4.33)	10 (0.39)	130 (5.12)	116 (4.57)	3.5 (0.14)	90 (3.54)	100 (3.94)	58 (2.28)	50 (1.97)	9 (0.35)	M8	198 (7.80)	172 (6.77)	228 (8.98)	202 (7.95)
	1FT6062													223 (8.78)	197 (7.76)	253 (9.96)	227 (8.94)	
	1FT6064													273 (10.75)	247 (9.72)	303 (11.93)	277 (10.91)	

Shaft height	Type	DIN IEC	Incremental encoder sin/cos 1 V _{pp} Absolute encoder (EnDat)				DE shaft extension						
			k LB	o -	k LB	o -	d D	d ₆ -	l E	t GA	u F		
48	1FT6041		228 (8.98)	157 (6.18)	263 (10.35)	192 (7.56)	19 (0.75)	M6	40 (1.57)	21.5 (0.85)	6 (0.24)		
	1FT6044		278 (10.94)	207 (8.15)	313 (12.32)	242 (9.53)							
63	1FT6061		228 (8.98)	172 (6.77)	258 (10.16)	202 (7.95)	24 (0.94)	M8	50 (1.97)	27 (1.06)	8 (0.31)		
	1FT6062		253 (9.96)	197 (7.76)	283 (11.14)	227 (8.94)							
	1FT6064		303 (11.93)	247 (9.72)	333 (13.11)	277 (10.91)							

1FT604 .
1FT606 .

Shaft design
with fitted key

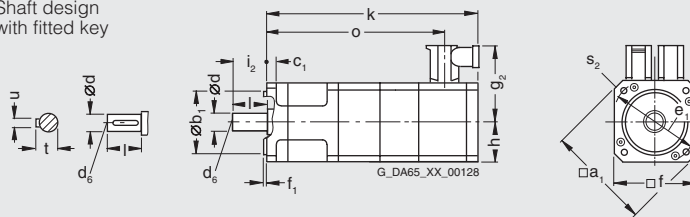

1) IM B5
2) IM B14

AC motors

Dimension drawings - synchronous motors

1FT6 motors with/without DRIVE-CLiQ Natural cooling

For motor		Dimensions in mm (in)														Resolver			
Shaft height	Type	DIN IEC	a ₁ P	b ₁ N	c ₁ LA	e ₁ M	f AB	f ₁ T	g ₂ -	h H	i ₂ -	s ₂ ¹⁾ S	s ₂ ²⁾ S	o ₁ -	without brake		with brake		
															k LB	o -	k LB	o -	
1FT6, type IM B5, natural cooling, with connector, with/without brake																			
80	1FT6081		194 (7.64)	130 (5.12)	12 (0.47)	165 (6.50)	155 (6.10)	3.5 (0.14)	127.5 (5.02)	77.5 (3.05)	58 (2.28)	11 (0.43)	M10	76 (2.99)	221 (8.70)	113 (4.45)	248 (9.76)	140 (5.51)	
	1FT6082														246 (9.69)	138 (5.43)	273 (10.75)	165 (6.50)	
	1FT6084														296 (11.65)	188 (7.40)	342 (13.46)	234 (9.21)	
	1FT6086														346 (13.62)	238 (9.37)	392 (15.43)	284 (11.18)	

		Incremental encoder sin/cos 1 V _{pp}				DE shaft extension					
Shaft height	Type	DIN IEC	without brake		with brake		d D	d ₆ -	l E	t GA	u F
			k LB	o -	k LB	o -					
80	1FT6081		221 (8.70)	113 (4.45)	248 (9.76)	140 (5.51)	32 (1.26)	M12	58 (2.28)	35 (1.38)	10 (0.39)
	1FT6082		246 (9.69)	138 (5.43)	273 (10.75)	165 (6.50)					
	1FT6084		296 (11.65)	188 (7.40)	342 (13.46)	234 (9.21)					
	1FT6086		346 (13.62)	238 (9.37)	392 (15.43)	284 (11.18)					

1FT608 .

Shaft design
with fitted key

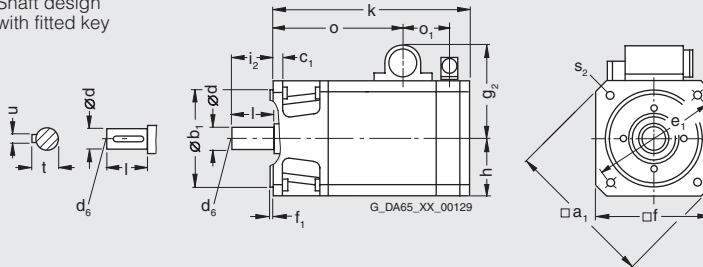

1) IM B5
2) IM B14

AC motors

Dimension drawings - synchronous motors

1FT6 motors with/without DRIVE-CLiQ Natural cooling

For motor		Dimensions in mm (in)													Connector Size		
Shaft height	Type	DIN IEC	a ₁	b ₁	c ₁	e ₁	f	f ₁	g ₂	g ₂	h	i ₂	p	s ₂ ¹⁾	s ₂ ²⁾	o ₁	
			P	N	LA	M	AB	T	-	-	H	-	HD	S _S	S _S	-	
1FT6, type IM B5, natural cooling, with connector, with/without brake																	
100	1FT6102		240 (9.45)	180 (7.09)	13 (0.51)	215 (8.46)	192 (7.56)	4 (0.16)	146 (5.75)	172 (6.77)	96 (3.78)	80 (3.15)	155 (6.10)	14 (0.55)	M12	76 (2.99)	
	1FT6105																
	1FT6108																
132	1FT6132		-	250 (9.84)	18 (0.71)	300 (11.81)	260 (10.24)	5 (0.20)	172.5 (6.79)	198.5 (7.81)	132 (5.20)	82 (3.23)	245 (9.65)	18 (0.71)	-	66 (2.60)	
	1FT6134																
	1FT6136																

Shaft height	Type	DIN IEC	Resolver				Incremental encoder sin/cos 1 V _{pp} Absolute encoder (EnDat)				DE shaft extension				
			without brake		with brake		without brake		with brake		d	d ₆	l	t	u
			k LB	o -	k LB	o -	k LB	o -	k LB	o -	D	-	E	GA	F
100	1FT6102		295 (11.61)	186 (7.32)	341 (13.43)	232 (9.13)	295 (11.61)	186 (7.32)	341 (13.43)	232 (9.13)	38 (1.5)	M12	80 (3.15)	41 (1.61)	10 (0.39)
	1FT6105		370 (14.57)	261 (10.28)	416 (16.38)	307 (12.09)	370 (14.57)	261 (10.28)	416 (16.38)	307 (12.09)					
	1FT6108		470 (18.50)	361 (14.21)	516 (20.31)	407 (16.02)	470 (18.50)	361 (14.21)	516 (20.31)	407 (16.02)					
132	1FT6132		423 (16.65)	288 (11.34)	473 (18.62)	338 (13.31)	423 (16.65)	288 (11.34)	473 (18.62)	338 (13.31)	48 (1.89)	M16	82 (3.23)	52.5 (2.07)	14 (0.55)
	1FT6134		473 (18.62)	338 (13.31)	523 (20.59)	388 (15.28)	473 (18.62)	338 (13.31)	523 (20.59)	388 (15.28)					
	1FT6136		523 (20.59)	388 (15.28)	573 (22.56)	438 (17.24)	523 (20.59)	388 (15.28)	573 (22.56)	438 (17.24)					

1FT610 . Shaft design with fitted key

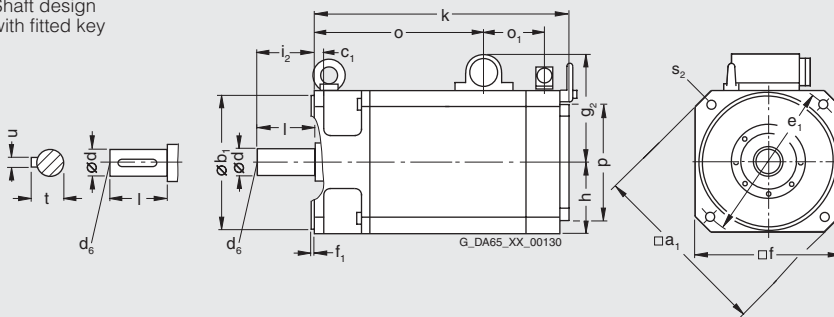

1FT613 .

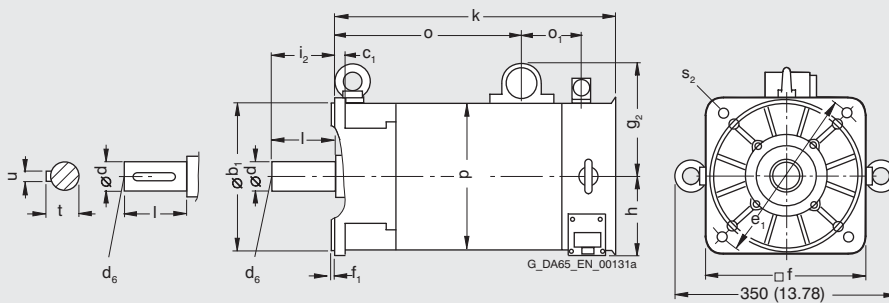

1) IM B5
2) IM B14

AC motors

Dimension drawings - synchronous motors

1FT6 motors without/with DRIVE-CLiQ Natural cooling

Shaft height	Type	Dimensions in mm (in)										Terminal box					
		DIN IEC	a ₁ P	b ₁ N	c ₁ LA	e ₁ M	f AB	f ₁ T	g ₂ -	g ₂ -	h H	i ₂ -	p HD	s ₂ ¹⁾ S ₂	s ₂ ²⁾ S ₂	s ₃ -	o ₁ -
1FT6, type IM B5, natural cooling, with terminal box, with/without brake																	
100	1FT6102 1FT6105 1FT6108		240 (9.45)	180 (7.09)	13 (0.51)	215 (8.46)	192 (7.56)	4 (0.16)	155 (6.10)	160 (6.30)	96 (3.78)	80 (3.15)	155 (6.10)	14 (0.55)	M12	PG 29	76 (2.99)
132	1FT6132 1FT6134 1FT6136		-	250 (9.84)	18 (0.71)	300 (11.81)	260 (10.24)	5 (0.20)	-	194 (7.64)	132 (5.20)	82 (3.23)	245 (9.65)	18 (0.71)	-	PG 29/ PG 36	-

Shaft height	Type	DIN IEC	Resolver				Incremental encoder sin/cos 1 V _{pp} Absolute encoder (EnDat)				DE shaft extension				
			without brake		with brake		without brake		with brake		d D	d ₆ -	l E	t GA	u F
			k LB	o -	k LB	o -	k LB	o -	k LB	o -					
100	1FT6102 1FT6105 1FT6108		295 (11.61)	186 (7.32)	341 (13.43)	232 (9.13)	295 (11.61)	186 (7.32)	341 (13.43)	232 (9.13)	38 (1.5)	M12	80 (3.15)	41 (1.61)	10 (0.39)
132	1FT6132 1FT6134 1FT6136		423 (16.65)	288 (11.34)	473 (18.62)	338 (13.31)	423 (16.65)	288 (11.34)	473 (18.62)	338 (13.31)	48 (1.89)	M16	82 (3.23)	51.5 (2.03)	14 (0.55)

1FT610 .

Shaft design
with fitted key

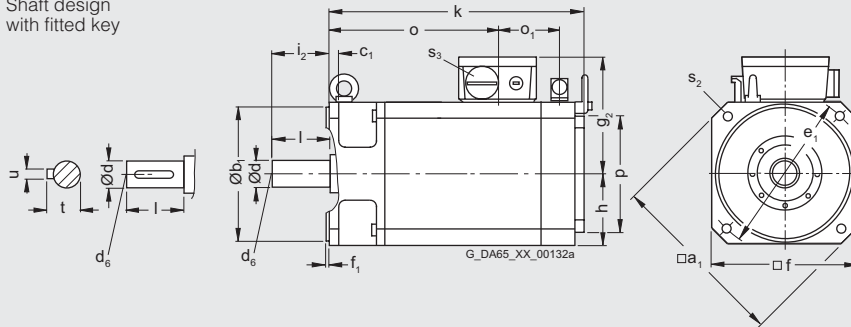

1FT613 .

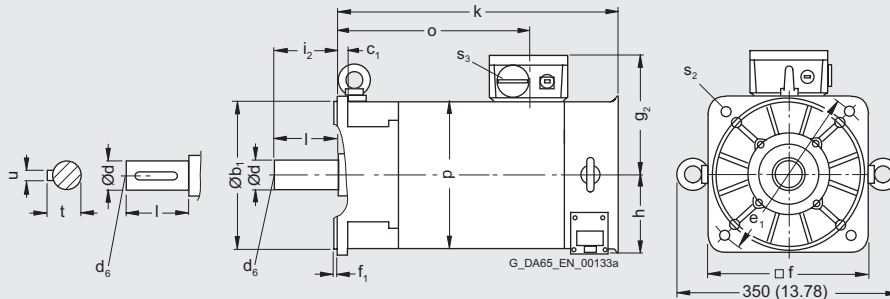

1) IM B5
2) IM B14

AC motors

Dimension drawings - synchronous motors

1FT6 motors without/with DRIVE-CLiQ
Forced ventilation

For motor		Dimensions in mm (in)										Connector					
Shaft height	Type	DIN IEC	a_1	b_1	c_1	e_1	f	f_1	g_2	g_2	h	i_2	p	$s_2^{1)}$	$s_2^{2)}$	o_1	o_2
			P	N	LA	M	AB	T	-	-	H	-	HD	S	S	-	-
1FT6, type IM B5, forced ventilation, with connector, with/without brake																	
80	1FT6084		194 (7.64)	130 (5.12)	12 (0.47)	165 (6.50)	185 (7.28)	3.5 (0.14)	140 (5.51)	154 (6.06)	93 (3.66)	58 (2.28)	175 (6.89)	11 (0.43)	M10	76 (2.99)	169 (6.65)
	1FT6086																
100	1FT6105		240 (9.45)	180 (7.09)	13 (0.51)	215 (8.46)	221 (8.70)	4 (0.16)	158 (6.22)	172 (6.77)	111 (4.37)	80 (3.15)	212 (8.35)	14 (0.55)	M12	76 (2.99)	170 (6.69)
	1FT6108																

Shaft height	Type	DIN IEC	Resolver				DE shaft extension										
			k	o	k	o	d	d ₆	l	t	u						
			Incremental encoder sin/cos 1 V _{pp} Absolute encoder (EnDat)														
			without brake		with brake												
80	1FT6084		399 (15.71)	188 (7.40)	445 (17.52)	234 (9.21)	32 (1.26)	M12	58 (2.28)	35 (1.38)	10 (0.39)						
	1FT6086		449 (17.68)	238 (9.37)	495 (19.49)	284 (11.18)											
100	1FT6105		473 (18.62)	261 (10.28)	519 (20.43)	307 (12.09)	38 (1.5)	M12	80 (3.15)	41 (1.61)	10 (0.39)						
	1FT6108		573 (22.56)	361 (14.21)	619 (24.37)	407 (16.02)											

1FT608 .

Shaft design with fitted key

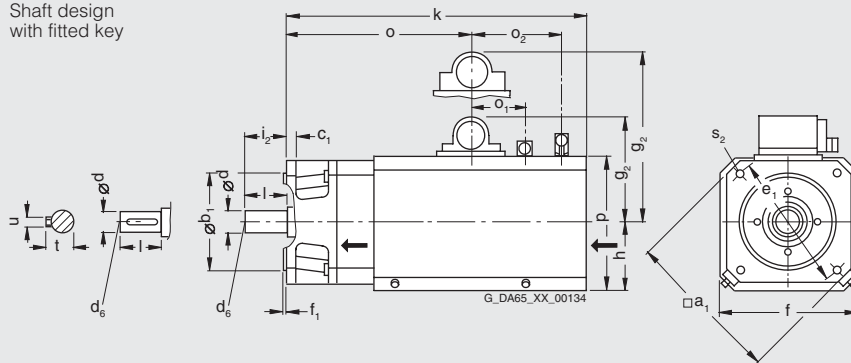

1FT610 .

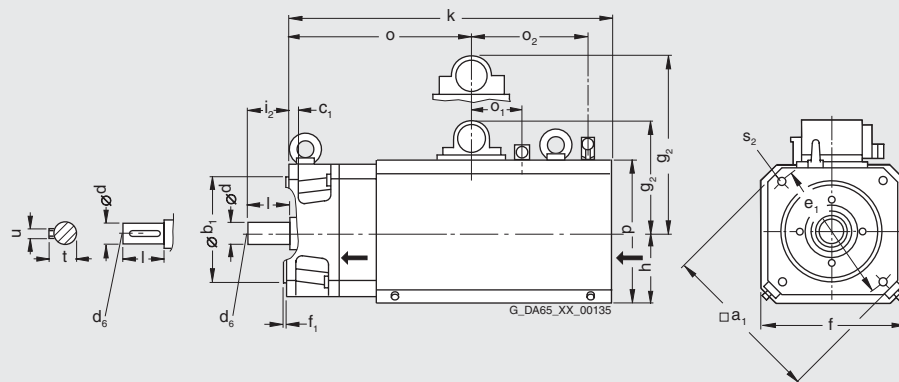

1) IM B5
2) IM B14

AC motors

Dimension drawings - synchronous motors

1FT6 motors without/with DRIVE-CLiQ Forced ventilation

For motor		Dimensions in mm (in)										Connector				
Shaft height	Type	DIN IEC	a_1	b_1	c_1	e_1	f	f_1	g_2	h	i_2	p	$s_2^{1)}$	$s_2^{2)}$	o_1	o_2
			P	N	LA	M	AB	T	-	H	-	HD	S	S	-	-

1FT6, type IM B5, forced ventilation, with connector, with/without brake																
132	1FT6132	-	250	18	300	260	5	198.5	132	82	245	18	-	66	-	
	1FT6134		(9.84)	(0.71)	(11.81)	(10.24)	(0.20)	(7.81)	(5.20)	(3.23)	(9.65)	(0.71)		(2.60)		
	1FT6136															

Shaft height	Type	DIN IEC	Resolver		Incremental encoder sin/cos		1 V _{pp}		Absolute encoder (EnDat)		without brake		with brake		DE shaft extension			
			k	o	k	o	d	d_6	l	t	u	GA	F	E	GA	F		
132	1FT6132		541	288	591	338	48	M16	82	51.5	14							
	1FT6134		(21.30)	(11.34)	(23.27)	(13.31)	(1.89)		(3.23)	(2.03)	(0.55)							
	1FT6136		591	338	641	388												
			(23.27)	(13.31)	(25.24)	(15.28)												
			641	388	691	438												
			(25.24)	(15.28)	(27.20)	(17.24)												

1FT613 .

Shaft design with fitted key

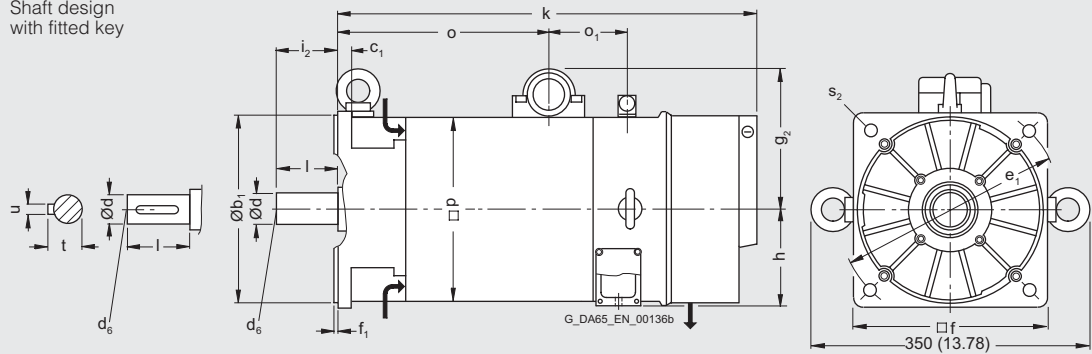

1) IM B5
2) IM B14

AC motors

Dimension drawings - synchronous motors

1FT6 motors without/with DRIVE-CLiQ Forced ventilation

For motor		Dimensions in mm (in)								Terminal box											
Shaft height	Type	DIN IEC	a ₁ P	b ₁ N	c ₁ LA	e ₁ M	f AB	f ₁ T	gk 130			gk 230		gk 420		h H	i ₂ -	p HD	s ₂ ¹⁾ S	s ₂ ²⁾ S	s ₃ -
									g ₂ -	g ₂ -	g ₂ -	g ₂ -	g ₂ -	g ₂ -							
100	1FT6105 1FT6108		240 (9.45)	180 (7.09)	13 (0.51)	215 (8.46)	221 (8.70)	4 (0.16)	167 (6.57)	172 (6.77)	-	111 (4.37)	80 (3.15)	212 (8.35)	14 (0.55)	M12	PG 29				
132	1FT6132 1FT6134 1FT6136		-	250 (9.84)	18 (0.71)	300 (11.81)	260 (10.24)	5 (0.20)	-	186.5 (7.34)	202 (7.95)	132 (5.20)	82 (3.23)	245 (9.65)	18 (0.71)	-	PG 29/ PG 36				

Shaft height	Type	DIN IEC	Resolver Incremental encoder sin/cos 1 V _{pp} Absolute encoder (EnDat) without brake with brake				DE shaft extension						
			o ₁ -	o ₂ -	k LB	o -	k LB	o -	d D	d ₆ -	l E	t GA	u F
100	1FT6105 1FT6108		76 (2.99)	170 (6.69)	473 (18.62) 573 (22.56)	261 (10.28) 361 (14.21)	519 (20.43) 619 (24.37)	307 (12.09) 407 (16.02)	38 (1.50)	M12	80 (3.15)	41 (1.61)	10 (0.39)
132	1FT6132 1FT6134 1FT6136		-	-	541 (21.30) 591 (23.27) 641 (25.24)	288 (11.34) 338 (13.31) 388 (15.28)	591 (23.27) 641 (25.24) 691 (27.20)	338 (13.31) 388 (15.28) 438 (17.24)	48 (1.89)	M16	82 (3.23)	51.5 (2.03)	14 (0.55)

1FT610 .

Shaft design with fitted key

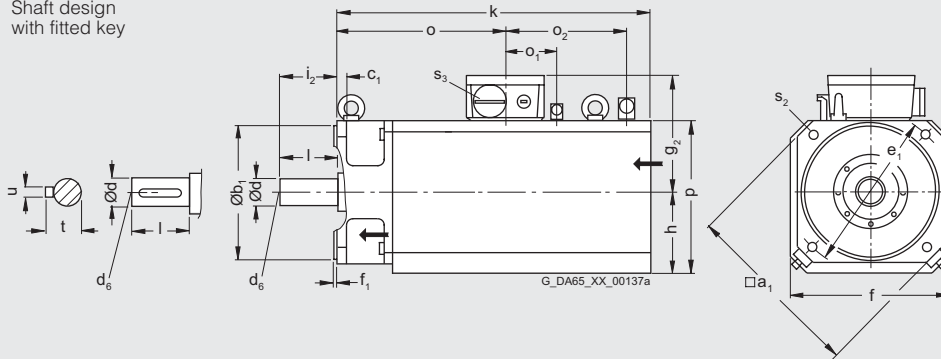

1FT613 .

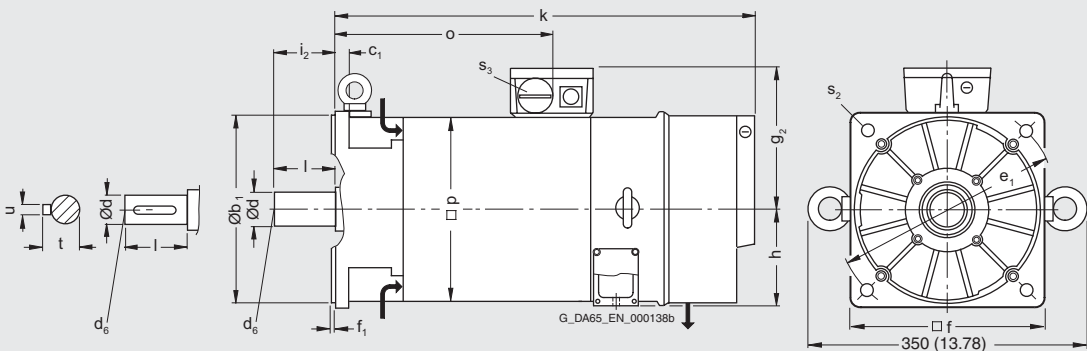

1) IM B5
2) IM B14

AC motors

Dimension drawings - synchronous motors

1FT6 Big Servo motors without/with DRIVE-CLiQ Forced ventilation

For motor Dimensions in mm (in)

Shaft height	Type	DIN IEC	a B	b A	b ₁ N	c LA	e BB	e ₁ M	f AB	f ₁ T	f ₂ AB	h H	i ₂ -	k LB	m BA	m ₁ -	m ₂ S
160	1FT6163		444 (17.48)	254 (10.00)	300 (11.81)	17 (0.67)	493 (19.41)	350 (13.78)	314 (12.36)	5 (0.20)	286 (11.26)	160 (6.30)	110 (4.33)	707 (27.83)	31 (1.22)	65 (2.56)	16 (0.63)
	1FT6168		544 (21.42)				593 (23.35)							807 (31.77)			

DE shaft extension

Shaft height	Type	DIN IEC	n AA	o -	p HD	p ₁ AC	s K	s ₂ S	s ₃ -	w ₁ C	d D	d ₆ -	l E	t GA	u F
160	1FT6163		52 (2.05)	391.5 (15.41)	403.5 (15.89)	294 (11.57)	14 (0.55)	18 (0.71)	M50 x 1.5	70 (2.76)	55 (2.17)	M20	110 (4.33)	59 (2.32)	16 (0.63)
	1FT6168			491.5 (19.35)											

1FT616 .

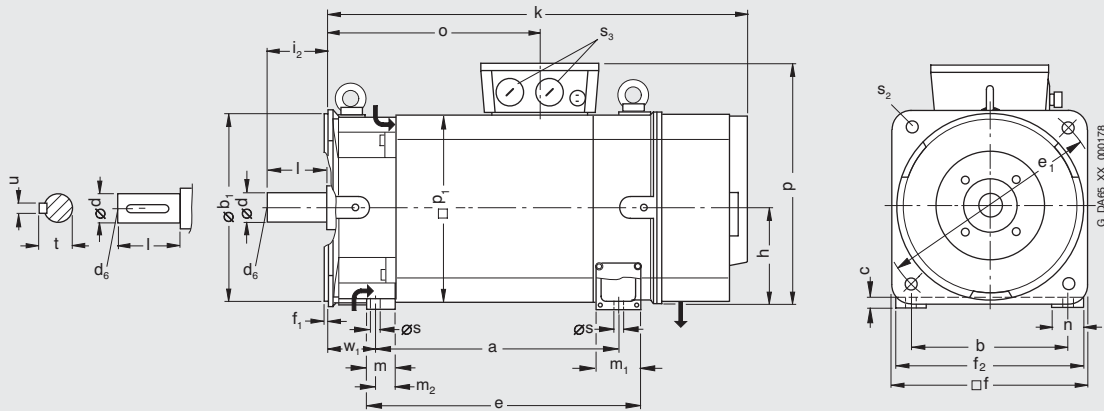

AC motors

Dimension drawings - synchronous motors

1FT6 motors without/with DRIVE-CLiQ Water cooling

Shaft height	Type	DIN IEC	Dimensions in mm (in)							Connector size				h H	i ₂	p HD	s ₂ ¹⁾ S	s ₂ ²⁾ S
			a ₁ P	b ₁ N	c ₁ LA	e ₁ M	f AB	f ₁ T	g ₂	g ₂	g ₂	g ₂	1					
1FT6, type IM B5, water cooling, with connector, with/without brake																		
63	1FT6062 1FT6064		146 (5.75)	110 (4.33)	10 (0.39)	130 (5.12)	116 (4.57)	3.5 (0.14)	100 (3.94)	99 (3.90)	-	-	58 (2.28)	50 (1.97)	-	9 (0.35)	M8	
80	1FT6084 1FT6086		194 (7.64)	130 (5.12)	12 (0.47)	165 (6.50)	155 (6.10)	3.5 (0.14)	-	-	139.5 (5.49)	153.5 (6.04)	77.5 (3.05)	58 (2.28)	-	11 (0.43)	M10	

Shaft height	Type	DIN IEC	Resolver Incremental encoder sin/cos 1 V _{pp} Absolute encoder (EnDat)				Resolver		Incremental encoder sin/cos 1 V _{pp} Absolute encoder (EnDat)		DE shaft extension						
			without brake	with brake	with brake/ without brake	with brake/ without brake	k LB	o ₁	k LB	o ₁	d D	d ₆	l E	t GA	u F		
63	1FT6062 1FT6064		-	-	-	-	-	253 (9.96)	227 (8.91)	283 (11.14)	227 (8.91)	24 (0.94)	M8	50 (1.97)	27 (1.06)	8 (0.31)	
80	1FT6084 1FT6086		76 (2.99)	296 (11.65)	188 (7.40)	342 (13.46)	234 (9.21)	-	-	-	-	-	32 (1.26)	M12	58 (2.28)	35 (1.38)	10 (0.39)

1FT606 .

Shaft design
with fitted key

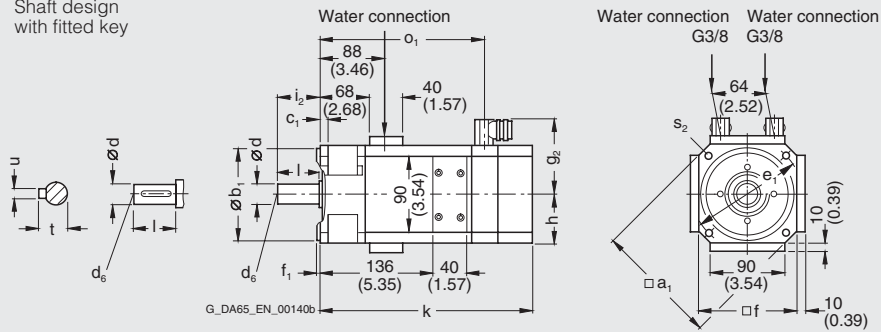

1FT608 .

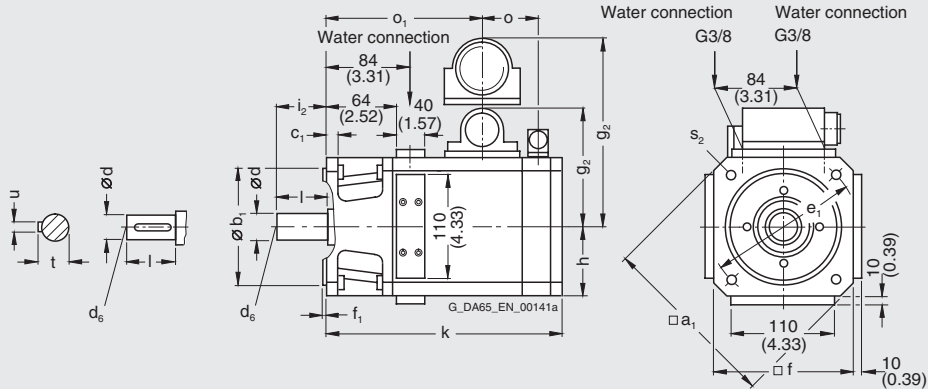

1) IM B5
2) IM B14

AC motors

Dimension drawings - synchronous motors

1FT6 motors without/with DRIVE-CLiQ Water cooling

For motor		Dimensions in mm (in)										Connector size				
Shaft height	Type	DIN IEC	a_1	b_1	c_1	e_1	f	f_1	g_2	g_2	h	i_2	p	$s_2^{1)}$	$s_2^{2)}$	o
			P	N	LA	M	AB	T	-	-	H	-	HD	S	S	-
1FT6, type IM B5, water cooling, with connector, with/without brake																
100	1FT6105		240	180	13	215	192	4	158	172	96	80	155	14	M12	76
	1FT6108		(9.45)	(7.09)	(0.51)	(8.46)	(7.56)	(0.16)	(6.22)	(6.77)	(3.78)	(3.15)	(6.10)	(0.55)		(2.99)

Shaft height	Type	DIN IEC	Resolver/Incremental encoder $\sin/\cos 1 V_{pp}$ Absolute encoder (EnDat)		DE shaft extension		d	d_6	l	t	u
			without brake	with brake	LB	o_1					
100	1FT6105		370	261	416	307	38	M12	80	41	10
	1FT6108		(14.57)	(10.28)	(16.38)	(12.09)	(1.50)		(3.15)	(1.61)	(0.39)
			470	361	516	407					
			(18.50)	(14.21)	(20.31)	(16.02)					

1FT610 .

Shaft design with fitted key

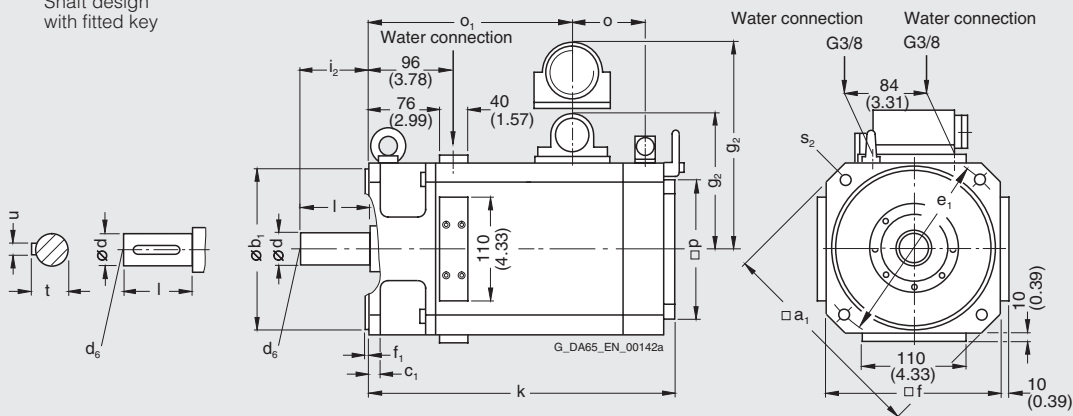

1) IM B5
2) IM B14

AC motors

Dimension drawings - synchronous motors

1FT6 motors without/with DRIVE-CLiQ
Water cooling

For motor		Dimensions in mm (in)																	Resolver/Incremental encoder			
Shaft height	Type	DIN IEC	a ₁	b ₁	c ₁	e ₁	f	f ₁	g ₂	h	i ₂	k	o	k	o	o ₁	p	s ₂	s ₃			
			P	N	LA	M	AB	T	-	H	-	LB	-	LB	-	-	HD	S	-	sin/cos 1 V _{pp} Absolute encoder (EnDat) without brake with brake		
1FT6, type IM B5, water cooling, with terminal box gk230 for n_{rated} ≤ 2000 rpm, with/without brake																						
100	1FT6105		240	180	13	215	192	4	161	96	80	370	261	416	307	76	155	14	PG29			
	1FT6108		(9.45)	(7.09)	(0.51)	(8.46)	(7.56)	(0.16)	(6.34)	(3.78)	(3.15)	(14.57)	(10.28)	(16.38)	(12.09)	(2.99)	(6.10)	(0.55)				
1FT6, type IM B5, water cooling, with terminal box gk420 for n_{rated} = 3000 rpm, with/without brake																						
100	1FT6105		240	180	13	215	192	4	176	96	80	370	261	416	307	-	155	14	PG36			
	1FT6108		(9.45)	(7.09)	(0.51)	(8.46)	(7.56)	(0.16)	(6.93)	(3.78)	(3.15)	(14.57)	(10.28)	(16.38)	(12.09)		(6.10)	(0.55)				

DE shaft extension

Shaft height	Type	DIN IEC	d	d ₆	l	t	u
			D	-	E	GA	F
100	1FT6105		38	M12	80	41	10
	1FT6108		(1.5)		(3.15)	(1.61)	(0.39)
100	1FT6105		38	M12	80	41	10
	1FT6108		(1.50)		(3.15)	(1.61)	(0.39)

1FT610 .
with terminal box
gk320

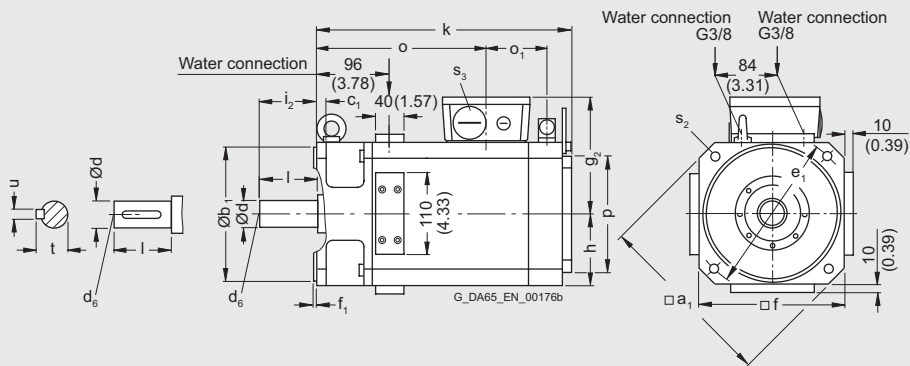

1FT610 .
with terminal box
gk420

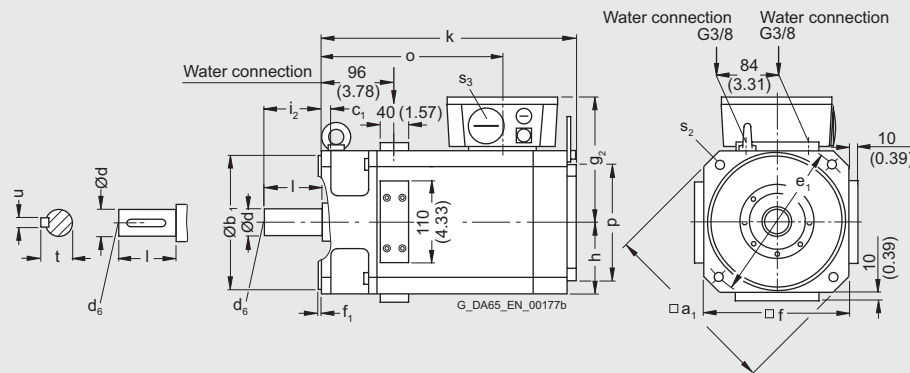

AC motors

Dimension drawings - synchronous motors

1FT6 Big Servo motors without/with DRIVE-CLiQ Water cooling

For motor		Dimensions in mm (in)																	
Shaft height	Type	DIN IEC	a B	b A	b ₁ N	c LA	c ₁ -	e BB	e ₁ M	f AB	f ₁ T	f ₂ -	h H	i ₂ -	k LB	m BA	m ₁ -	m ₂ -	
1FT6 Big Servo, type IM B35, water cooling, with terminal box																			
132	1FT6132		342 (13.46)	216 (8.50)	250 (9.84)	14 (0.55)	16 (0.63)	366 (14.41)	300 (11.81)	260 (10.24)	5 (0.20)	245 (9.65)	132 (5.20)	82 (3.23)	423 (16.65)	36 (1.42)	53 (2.09)	23 (0.91)	
	1FT6134		392 (15.43)					416 (16.38)							473 (18.62)				
	1FT6136		442 (17.40)					466 (18.35)							523 (20.59)				
	1FT6138		517 (20.35)					541 (21.30)							598 (23.54)				

Shaft height	Type	DIN IEC											DE shaft extension				
			n AA	o -	p HD	p ₁ AC	s K	s ₂ K	s ₃ -	s ₃ -	w ₁ C	d D	d ₆ -	l E	t GA	u F	
132	1FT6132		14 (0.55)	255.5 (10.06)	350.5 (13.80)	245 (9.65)	12 (0.47)	18 (0.71)	M32 x 1.5	M40 x 1.5	53 (2.09)	48 (1.89)	M16	82 (3.23)	51.5 (2.03)	14 (0.55)	
	1FT6134			305.5 (12.03)					M40 x 1.5	M50 x 1.5							
	1FT6136			355.5 (14.00)					M50 x 1.5	M50 x 1.5							
	1FT6138			430.5 (16.95)					M50 x 1.5	M50 x 1.5							

1FT613 .

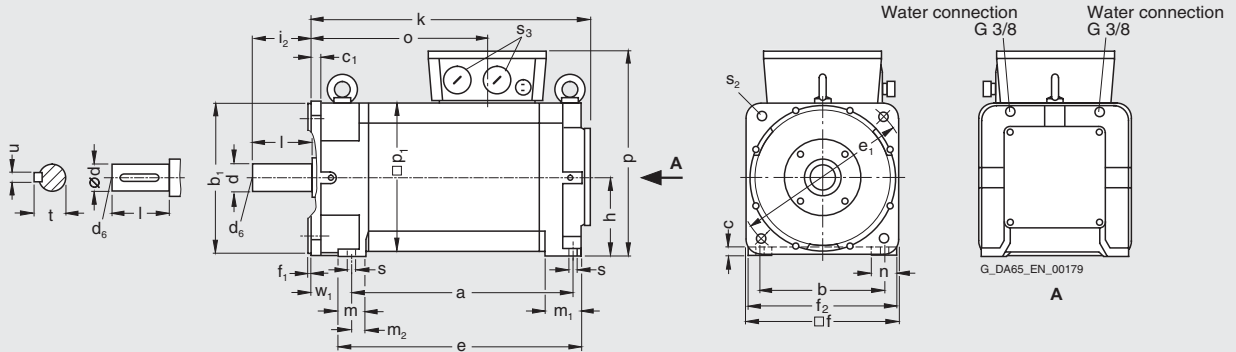

AC motors

Dimension drawings - synchronous motors

1FT6 Big Servo motors without/with DRIVE-CLiQ
Water cooling

For motor		Dimensions in mm (in)																	
Shaft height	Type	DIN IEC	a B	b A	b ₁ N	c LA	c ₁ -	e BB	e ₁ M	f AB	f ₁ T	f ₂ -	h H	i ₂ -	k LB	m BA	m ₁ -	m ₂ -	
1FT6 Big Servo, type IM B35, water cooling																			
132	1FT6132		342 (13.46)	216 (8.50)	250 (9.84)	14 (0.55)	16 (0.63)	366 (14.41)	300 (11.81)	260 (10.24)	5 (0.20)	245 (9.65)	132 (5.20)	82 (3.23)	423 (16.65)	36 (1.42)	53 (2.09)	23 (0.91)	
	1FT6134		392 (15.43)					416 (16.38)							473 (18.62)				
	1FT6136		442 (17.40)					466 (18.35)							523 (20.59)				
	1FT6138		517 (20.35)					541 (21.30)							598 (23.54)				
160	1FT6163		507 (19.96)	254 (10.00)	300 (11.81)	17 (0.67)	17.5 (0.69)	532 (20.94)	350 (13.78)	314 (12.36)	5 (0.20)	294 (11.57)	160 (6.30)	110 (4.33)	590 (23.23)	44 (1.73)	77 (3.03)	30.5 (1.20)	
	1FT6168		607 (23.90)					632 (24.88)							690 (27.17)				

Shaft height	Type	DIN IEC	$n_N = 1500 \text{ rpm}$										$n_N = 2500 \text{ rpm}$					DE shaft extension	
			n AA	o -	p HD	p ₁ AC	s K	s ₂ K	s ₃ -	s ₃ -	w ₁ C	d D	d ₆ -	l E	t GA	u F			
132	1FT6132		14 (0.55)	255.5 (10.06)	350.5 (13.80)	245 (9.65)	12 (0.47)	18 (0.71)	M32 x 1.5	M40 x 1.5	53 (2.09)	48 (1.89)	M16	82 (3.23)	51.5 (2.03)	14 (0.55)			
	1FT6134			305.5 (12.03)					M40 x 1.5	M50 x 1.5									
	1FT6136			355.5 (14.00)					M50 x 1.5	M50 x 1.5									
	1FT6138			430.5 (16.95)					M50 x 1.5	M50 x 1.5									
160	1FT6163		17 (0.67)	391.5 (15.41)	403.5 (15.89)	294 (11.57)	14 (0.55)	18 (0.71)	M50 x 1.5	M50 x 1.5	56 (2.20)	55 (2.17)	M20	110 (4.33)	59 (2.32)	16 (0.63)			
	1FT6168			491.5 (19.35)															

1FT613 .

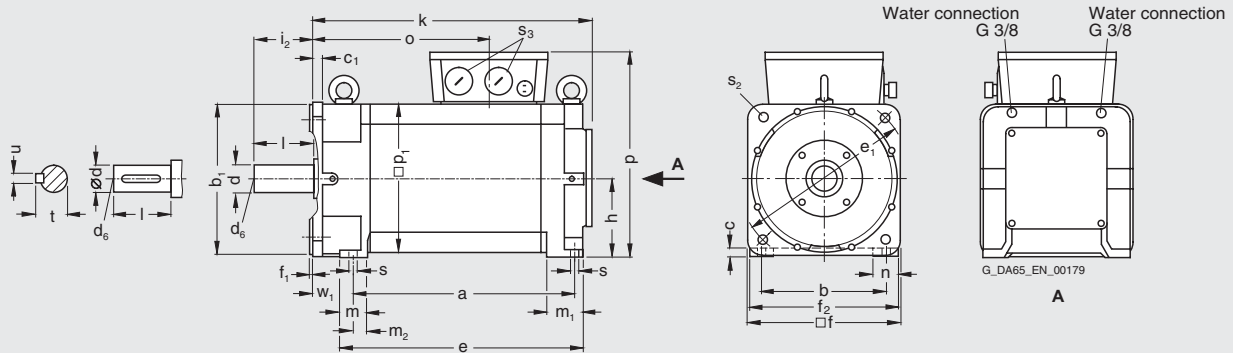

1FT616 .

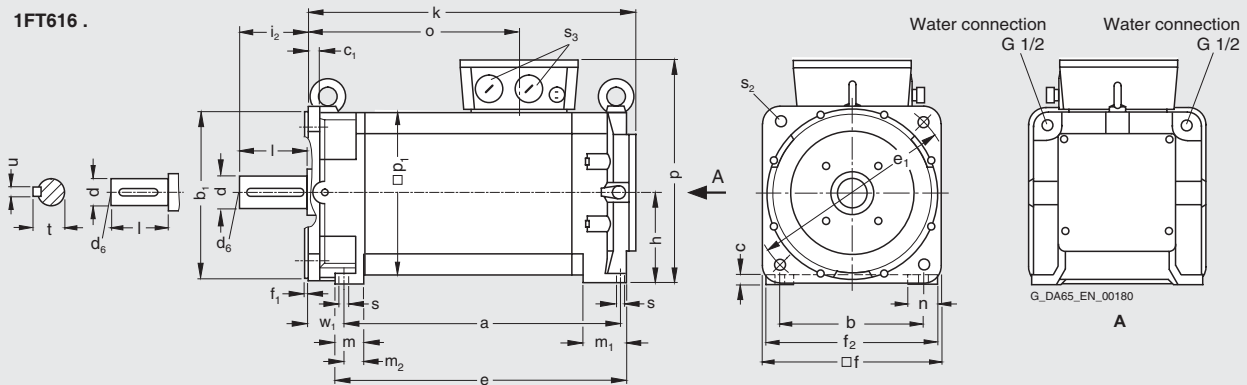

AC motors

Dimension drawings - synchronous motors

1FK7 Compact motors without/with DRIVE-CLIQ Natural cooling

For motor		Dimensions in mm (in)											Resolver					
Shaft height	Type	DIN IEC	a ₁ P	b ₁ N	c ₁ LA	e ₁ M	f AB	f ₁ T	g ₂ -	h H	i ₂ -	s ₂ S	without brake			with brake		
													k LB	o ₁ -	o ₂ -	k LB	o ₁ -	o ₂ -
1FK7 Compact, type IM B5, natural cooling, with connector, with/without brake																		
20	1FK7011-5	-	30 (1.18)	5 (0.20)	46 (1.81)	40 (1.57)	2.5 (0.10)	62.5 (2.46)	22.5 (0.89)	18 (0.71)	4.5 (0.18)	139 (5.47)	90 (3.54)	119 (4.69)	140 (5.51)	89 (3.50)	118 (4.65)	
	1FK7015-5	-	30 (1.18)	5 (0.20)	46 (1.81)	40 (1.57)	2.5 (0.10)	62.5 (2.46)	22.5 (0.89)	18 (0.71)	4.5 (0.18)	164 (6.46)	115 (4.53)	144 (5.67)	165 (6.50)	114 (4.49)	143 (5.63)	
28	1FK7022-5	-	40 (1.57)	10 (0.39)	63 (2.48)	55 (2.17)	2.5 (0.10)	75 (2.95)	27.5 (1.08)	20 (0.79)	5.4 (0.21)	153 (6.02)	95 (3.74)	128 (5.04)	175 (6.89)	95 (3.74)	150 (5.91)	
36	1FK7032-5	92 (3.62)	60 (2.36)	8 (0.31)	75 (2.95)	72 (2.83)	3 (0.12)	81 (3.19)	36 (1.42)	30 (1.18)	6.5 (0.26)	150 (5.91)	90 (3.54)	125 (4.92)	175 (6.89)	90 (3.54)	149 (5.87)	
	1FK7034-5	92 (3.62)	60 (2.36)	8 (0.31)	75 (2.95)	72 (2.83)	3 (0.12)	81 (3.19)	36 (1.42)	30 (1.18)	6.5 (0.26)	175 (6.89)	115 (4.53)	150 (5.91)	200 (7.87)	115 (4.53)	174 (6.85)	
48	1FK7040-5	120 (4.72)	80 (3.15)	10 (0.39)	100 (3.94)	96 (3.78)	3 (0.12)	90 (3.54)	48 (1.89)	40 (1.57)	7 (0.28)	134 (5.28)	73 (2.87)	106 (4.17)	163 (6.42)	73 (2.87)	135 (5.31)	
	1FK7042-5	120 (4.72)	80 (3.15)	10 (0.39)	100 (3.94)	96 (3.78)	3 (0.12)	90 (3.54)	48 (1.89)	40 (1.57)	7 (0.28)	162 (6.38)	101 (3.98)	134 (5.28)	191 (7.52)	101 (3.98)	163 (6.42)	
63	1FK7060-5	155 (6.10)	110 (4.33)	10 (0.39)	130 (5.12)	126 (4.96)	3.5 (0.14)	105 (4.13)	63 (2.48)	50 (1.97)	9 (0.35)	157 (6.18)	94 (3.70)	126 (4.96)	200 (7.87)	94 (3.70)	169 (6.65)	
	1FK7063-5	155 (6.10)	110 (4.33)	10 (0.39)	130 (5.12)	126 (4.96)	3.5 (0.14)	105 (4.13)	63 (2.48)	50 (1.97)	9 (0.35)	202 (7.95)	139 (5.47)	171 (6.73)	245 (9.65)	139 (5.47)	214 (8.43)	

Shaft height	Type	Basic absolute encoder (EnDat) (shaft height 48 and larger), Incremental encoder sin/cos1 V _{pp}						Absolute encoder (EnDat)						d D	d ₆ -	l E	t GA	u F	
		without brake			with brake			without brake			with brake								
		k LB	o ₁ -	o ₂ -	k LB	o ₁ -	o ₂ -	k LB	o ₁ -	o ₂ -	k LB	o ₁ -	o ₂ -						
20	1FK7011-5	-	-	-	-	-	-	-	-	-	-	-	-	-	8 (0.31)	M3	18 (0.71)	8.8 (0.35)	2 (0.08)
	1FK7015-5	-	-	-	-	-	-	-	-	-	-	-	-	-	8 (0.31)	M3	18 (0.71)	8.8 (0.35)	2 (0.08)
28	1FK7022-5	178 (7.01)	95 (3.74)	128 (5.04)	200 (7.87)	95 (3.74)	150 (5.91)	178 (7.01)	95 (3.74)	128 (5.04)	200 (7.87)	95 (3.74)	150 (5.91)	9 (0.35)	M3	20 (0.79)	10.2 (0.40)	3 (0.12)	
36	1FK7032-5	175 (6.89)	90 (3.54)	125 (4.92)	200 (7.87)	90 (3.54)	149 (5.87)	175 (6.89)	90 (3.54)	125 (4.92)	200 (7.87)	90 (3.54)	149 (5.87)	14 (0.55)	M5	30 (1.18)	16 (0.63)	5 (0.20)	
	1FK7034-5	200 (7.87)	115 (4.53)	150 (5.91)	225 (8.86)	115 (4.53)	174 (6.85)	200 (7.87)	115 (4.53)	150 (5.91)	225 (8.86)	115 (4.53)	174 (6.85)	14 (0.55)	M5	30 (1.18)	16 (0.63)	5 (0.20)	
48	1FK7040-5	155 (6.10)	73 (2.87)	106 (4.17)	184 (7.24)	73 (2.87)	135 (5.31)	163 (6.42)	73 (2.87)	106 (4.17)	192 (7.56)	73 (2.87)	135 (5.31)	19 (0.75)	M6	40 (1.57)	21.5 (0.85)	6 (0.24)	
	1FK7042-5	182 (7.17)	101 (3.98)	134 (5.28)	211 (8.31)	101 (3.98)	163 (6.42)	191 (7.52)	101 (3.98)	134 (5.28)	220 (8.66)	101 (3.98)	163 (6.42)	19 (0.75)	M6	40 (1.57)	21.5 (0.85)	6 (0.24)	
63	1FK7060-5	180 (7.09)	94 (3.70)	126 (4.96)	223 (8.78)	94 (3.70)	169 (6.65)	188 (7.40)	94 (3.70)	126 (4.96)	231 (9.09)	94 (3.70)	169 (6.65)	24 (0.94)	M8	50 (1.97)	27 (1.06)	8 (0.31)	
	1FK7063-5	225 (8.86)	139 (5.47)	171 (6.73)	268 (10.55)	139 (5.47)	214 (8.43)	233 (9.17)	139 (5.47)	171 (6.73)	276 (10.87)	139 (5.47)	214 (8.43)	24 (0.94)	M8	50 (1.97)	27 (1.06)	8 (0.31)	

1FK701.-5
1FK702.-5
1FK703.-5
1FK704.-5
1FK706.-5

Shaft design
with fitted key

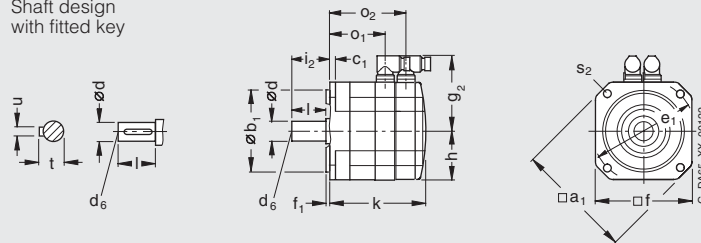

AC motors

Dimension drawings - synchronous motors

1FK7 Compact motors without/with DRIVE-CLiQ Natural cooling

For motor		Dimensions in mm (in)											Resolver					
Shaft height	Type	DIN IEC	a ₁ P	b ₁ N	c ₁ LA	e ₁ M	f AB	f ₁ T	g ₂ -	h H	i ₂ -	s ₂ S	without brake			with brake		
													k LB	o ₁ -	o ₂ -	k LB	o ₁ -	o ₂ -
1FK7 Compact, type IM B5, natural cooling, with connector, with/without brake																		
80	1FK7080-5		186 (7.32)	130 (5.12)	13 (0.51)	165 (6.50)	155 (6.10)	3.5 (0.14)	119.5 (4.70)	77.5 (3.05)	58 (2.28)	11 (0.43)	156 (6.14)	91 (3.58)	124 (4.88)	184 (7.24)	91 (3.58)	151 (5.94)
	1FK7083-5		186 (7.32)	130 (5.12)	13 (0.51)	165 (6.50)	155 (6.10)	3.5 (0.14)	119.5 (4.70)	77.5 (3.05)	58 (2.28)	11 (0.43)	194 (7.64)	129 (5.08)	162 (6.38)	245 (9.65)	129 (5.08)	207 (8.15)
100	1FK7100-5		240 (9.45)	180 (7.09)	13 (0.51)	215 (8.46)	192 (7.56)	4 (0.16)	138 (5.43)	96 (3.78)	80 (3.15)	14 (0.55)	185 (7.28)	113 (4.45)	153 (6.02)	204 (8.03)	113 (4.45)	172 (6.77)
	1FK7101-5		240 (9.45)	180 (7.09)	13 (0.51)	215 (8.46)	192 (7.56)	4 (0.16)	160 (6.30)	96 (3.78)	80 (3.15)	14 (0.55)	211 (8.31)	139 (5.47)	179 (7.05)	240 (9.45)	139 (5.47)	208 (8.19)
	1FK7103-5		240 (9.45)	180 (7.09)	13 (0.51)	215 (8.46)	192 (7.56)	4 (0.16)	160 (6.30)	96 (3.78)	80 (3.15)	14 (0.55)	237 (9.33)	165 (6.50)	205 (8.07)	266 (10.47)	165 (6.50)	234 (9.21)
	1FK7105-5		240 (9.45)	180 (7.09)	13 (0.51)	215 (8.46)	192 (7.56)	4 (0.16)	160 (6.30)	96 (3.78)	80 (3.15)	14 (0.55)	289 (11.38)	217 (8.54)	257 (10.12)	318 (12.52)	217 (8.54)	286 (11.26)

Shaft height	Type	Basic absolute encoder (EnDat) (shaft height 48 and larger), Incremental encoder sin/cos 1 V _{pp}						Absolute encoder (EnDat)										
		without brake			with brake			without brake			with brake			d D	d ₆ -	l E	t GA	u F
		k LB	o ₁ -	o ₂ -	k LB	o ₁ -	o ₂ -	k LB	o ₁ -	o ₂ -	k LB	o ₁ -	o ₂ -					
80	1FK7080-5	179 (7.05)	91 (3.58)	124 (4.88)	206 (8.11)	91 (3.58)	151 (5.94)	187 (7.36)	91 (3.58)	124 (4.88)	215 (8.46)	91 (3.58)	151 (5.94)	32 (1.26)	M12	58 (2.28)	35 (1.38)	10 (0.39)
	1FK7083-5	217 (8.54)	129 (5.08)	162 (6.38)	268 (10.55)	153 (6.02)	213 (8.39)	225 (8.86)	129 (5.08)	162 (6.38)	276 (10.87)	129 (5.08)	207 (8.15)	32 (1.26)	M12	58 (2.28)	35 (1.38)	10 (0.39)
100	1FK7100-5	208 (8.19)	113 (4.45)	153 (6.02)	227 (8.94)	113 (4.45)	172 (6.77)	216 (8.50)	113 (4.45)	153 (6.02)	235 (9.25)	113 (4.45)	172 (6.77)	38 (1.50)	M12	80 (3.15)	41 (1.61)	10 (0.39)
	1FK7101-5	234 (9.21)	139 (5.47)	179 (7.05)	263 (10.35)	139 (5.47)	208 (8.19)	242 (9.53)	139 (5.47)	179 (7.05)	271 (10.67)	139 (5.47)	208 (8.19)	38 (1.50)	M12	80 (3.15)	41 (1.61)	10 (0.39)
	1FK7103-5	260 (10.24)	165 (6.50)	205 (8.07)	289 (11.38)	165 (6.5)	234 (9.21)	268 (10.55)	165 (6.50)	205 (8.07)	297 (11.69)	165 (6.50)	234 (9.21)	38 (1.50)	M12	80 (3.15)	41 (1.61)	10 (0.39)
	1FK7105-5	312 (12.28)	217 (8.54)	257 (10.12)	341 (13.43)	217 (8.54)	286 (11.26)	320 (12.60)	217 (8.54)	257 (10.12)	349 (13.74)	217 (8.54)	286 (11.26)	38 (1.50)	M12	80 (3.15)	41 (1.61)	10 (0.39)

1FK708 . -5

Shaft design with fitted key

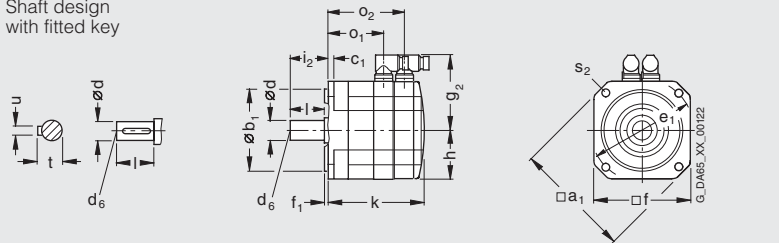

1FK7100-5 1FK7101-5 1FK7103-5 1FK7105-5

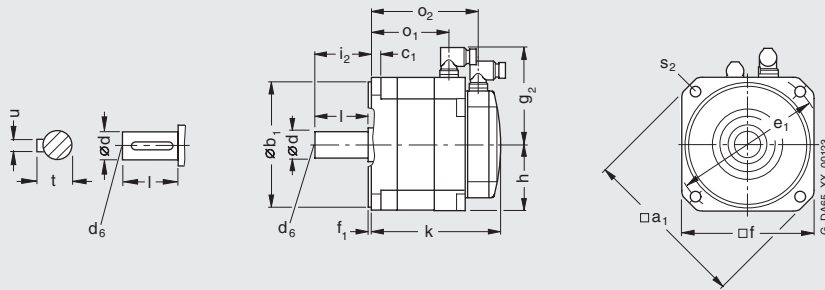

AC motors

Dimension drawings - synchronous motors

1FK7 High Dynamic motors without/with DRIVE-CLiQ, natural cooling

For motor		Dimensions in mm (in)											Resolver		
Shaft height	Type	DIN IEC	a_1	b_1	c_1	e_1	f	f_1	g_2	h	i_2	s_2	without/with brake		
			P	N	LA	M	AB	T	-	H	-	S	k LB	o_1	o_2
1FK7 High Dynamic, type IM B5, natural cooling, with connector, with/without brake															
36	1FK7033-7		92 (3.62)	60 (2.36)	8 (0.31)	75 (2.95)	72 (2.83)	3 (0.12)	78 (3.07)	36 (1.42)	30 (1.18)	6.5 (0.26)	170/195 (6.69/7.68)	108/108 (4.25/4.25)	145/170 (5.71/6.69)
48	1FK7043-7		120 (4.72)	80 (3.15)	10 (0.39)	100 (3.94)	96 (3.78)	3 (0.12)	90 (3.54)	48 (1.89)	40 (1.57)	7 (0.28)	191/220 (7.52/8.66)	130/130 (5.12/5.12)	163/192 (6.42/7.56)
	1FK7044-7											7 (0.28)	216/245 (8.51/9.65)	155/155 (6.10/6.10)	188/217 (7.40/8.54)
63	1FK7061-7		155 (6.10)	110 (4.33)	10 (0.39)	130 (5.12)	126 (4.96)	3.5 (0.14)	105 (4.13)	63 (2.48)	50 (1.97)	9 (0.35)	185/228 (7.28/8.98)	121/121 (4.76/4.76)	153/196 (6.02/7.72)
	1FK7064-7												249/292 (9.80/11.5)	185/185 (7.28/7.28)	217/260 (8.54/10.24)
80	1FK7085-7		186 (7.32)	130 (5.12)	13 (0.51)	165 (6.50)	155 (6.10)	3.5 (0.14)	141.5 (5.57)	77.5 (3.05)	60 (2.36)	11 (0.43)	261/304 (10.28/11.97)	190/191 (7.48/7.52)	229/272 (9.02/10.71)
	1FK7086-7								140.5 (5.53)				261/303 (10.28/11.93)	192/192 (7.56/7.56)	229/272 (9.02/10.71)

Shaft height	Type	DIN IEC	Basic absolute encoder (EnDat) (shaft height 48 and larger), Incremental encoder sin/cos1 V_{pp} without/with brake			Absolute encoder (EnDat) without/with brake			DE shaft extension				
			k LB	o_1	o_2	k LB	o_1	o_2	d D	d_6	l E	t GA	u F
36	1FK7033-7		194/219 (7.64/8.62)	109/109 (4.29/4.29)	144/168 (5.67/6.61)	194/219 (7.64/8.62)	109/109 (4.29/4.29)	144/168 (5.67/6.61)	14 (0.55)	M5	30 (1.18)	16 (0.63)	5 (0.20)
48	1FK7043-7		212/241 (8.35/9.49)	130/130 (5.12/5.12)	163/192 (6.42/7.56)	220/249 (8.66/9.80)	130/130 (5.12/5.12)	163/192 (6.42/7.56)	19 (0.75)	M6	40 (1.57)	21.5 (0.85)	6 (0.24)
	1FK7044-7		237/266 (9.33/10.47)	155/155 (6.10/6.10)	188/217 (7.40/8.54)	245/274 (9.65/10.79)	155/155 (6.10/6.10)	188/217 (7.40/8.54)					
63	1FK7061-7		208/251 (8.19/9.88)	121/121 (4.76/4.76)	154/197 (6.06/7.76)	217/260 (8.54/10.24)	121/121 (4.76/4.76)	154/197 (6.06/7.76)	24 (0.94)	M6	50 (1.97)	27 (1.06)	8 (0.31)
	1FK7064-7		272/315 (10.71/12.40)	185/185 (7.28/7.28)	218/261 (8.58/10.28)	281/324 (11.06/12.76)	185/185 (7.28/7.28)	218/261 (8.58/10.28)					
80	1FK7085-7		283/326 (11.14/12.83)	192/192 (7.56/7.56)	229/272 (9.02/10.71)	292/334 (11.50/13.15)	192/192 (7.56/7.56)	229/272 (9.02/10.71)	32 (1.26)	M12	58 (2.28)	35 (1.38)	10 (0.39)
	1FK7086-7												

Shaft design with fitted key

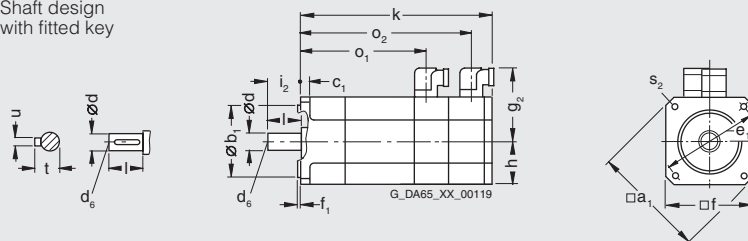

AC motors

Dimension drawings - synchronous motors

**1FT6 motors without/with DRIVE-CLiQ
with SP+ planetary gearbox, single-stage**

For motors		Dimensions in mm (in)											Resolver		Incremental encoder sin/cos 1 V _{pp} , Absolute encoder (EnDat)	
Shaft height	Type	F4	Planetary gearbox Type	D1	D2	D3	D4	L5	L6	L7	L8	without brake	with brake	without brake	with brake	
												K	K	K	K	
1FT6 with SP+ planetary gearbox, single-stage, type IM B5, natural cooling, with connector, without/with brake																
28	1FT6021	62 (2.44)	SP060S-MF1	60 (2.36)	16 (0.63)	5.5 (0.22)	68 (2.68)	138 (5.44)	28 (1.10)	20 (0.79)	6 (0.24)	283 (11.15)	308 (12.14)	283 (11.15)	308 (12.14)	
	1FT6024	62 (2.44)	SP060S-MF1	60 (2.36)	16 (0.63)	5.5 (0.22)	68 (2.68)	138 (5.44)	28 (1.10)	20 (0.79)	6 (0.24)	323 (12.73)	348 (13.71)	323 (12.73)	348 (13.71)	
36	1FT6031	62 (2.44)	SP060S-MF1	60 (2.36)	16 (0.63)	5.5 (0.22)	68 (2.68)	142 (5.59)	28 (1.10)	20 (0.79)	6 (0.24)	274 (10.80)	294 (11.58)	314 (12.37)	334 (13.16)	
	1FT6034	62 (2.44)	SP060S-MF1	60 (2.36)	16 (0.63)	5.5 (0.22)	68 (2.68)	142 (5.59)	28 (1.10)	20 (0.79)	6 (0.24)	314 (12.37)	334 (13.16)	354 (13.95)	374 (14.74)	
	1FT6034	76 (2.99)	SP075S-MF1	70 (2.76)	22 (0.87)	6.6 (0.26)	85 (3.35)	164 (6.46)	36 (1.42)	20 (0.79)	7 (0.28)	328 (12.92)	348 (13.71)	368 (14.50)	388 (15.29)	
48	1FT6041	76 (2.99)	SP075S-MF1	70 (2.76)	22 (0.87)	6.6 (0.26)	85 (3.35)	168 (6.62)	36 (1.42)	20 (0.79)	7 (0.28)	297 (11.70)	332 (13.08)	340 (13.40)	375 (14.78)	
	1FT6044	76 (2.99)	SP075S-MF1	70 (2.76)	22 (0.87)	6.6 (0.26)	85 (3.35)	168 (6.62)	36 (1.42)	20 (0.79)	7 (0.28)	347 (13.67)	382 (15.05)	390 (15.37)	425 (16.75)	
63	1FT6061	101 (3.98)	SP100S-MF1	90 (3.55)	32 (1.26)	9 (0.35)	120 (4.73)	217 (8.55)	58 (2.29)	30 (1.18)	10 (0.39)	327 (12.88)	357 (14.07)	357 (14.07)	387 (15.25)	
	1FT6062	101 (3.98)	SP100S-MF1	90 (3.55)	32 (1.26)	9 (0.35)	120 (4.73)	217 (8.55)	58 (2.29)	30 (1.18)	10 (0.39)	352 (13.87)	382 (15.05)	382 (15.05)	412 (16.23)	
	1FT6064	101 (3.98)	SP100S-MF1	90 (3.55)	32 (1.26)	9 (0.35)	120 (4.73)	217 (8.55)	58 (2.29)	30 (1.18)	10 (0.39)	402 (15.84)	432 (17.02)	432 (17.02)	462 (18.20)	
80	1FT6081	141 (5.56)	SP140S-MF1	130 (5.12)	40 (1.58)	11 (0.43)	165 (6.50)	283 (11.15)	82 (3.23)	30 (1.18)	12 (0.47)	392 (15.44)	419 (16.51)	392 (15.44)	419 (16.51)	
	1FT6082	141 (5.56)	SP140S-MF1	130 (5.12)	40 (1.58)	11 (0.43)	165 (6.50)	283 (11.15)	82 (3.23)	30 (1.18)	12 (0.47)	417 (16.43)	444 (17.49)	417 (16.43)	444 (17.49)	
	1FT6084	141 (5.56)	SP140S-MF1	130 (5.12)	40 (1.58)	11 (0.43)	165 (6.50)	283 (11.15)	82 (3.23)	30 (1.18)	12 (0.47)	467 (18.40)	513 (20.21)	467 (18.40)	513 (20.21)	
	1FT6086	141 (5.56)	SP140S-MF1	130 (5.12)	40 (1.58)	11 (0.43)	165 (6.50)	283 (11.15)	82 (3.23)	30 (1.18)	12 (0.47)	517 (20.37)	563 (22.18)	517 (20.37)	563 (22.18)	
	1FT6086	182 (7.17)	SP180S-MF1	160 (6.30)	55 (2.17)	13.5 (0.53)	215 (8.47)	310 (12.21)	82 (3.23)	30 (1.18)	15 (0.59)	544 (21.43)	590 (23.25)	544 (21.43)	590 (23.25)	

1FT602.
1FT603.
1FT604.
1FT606.
1FT608.

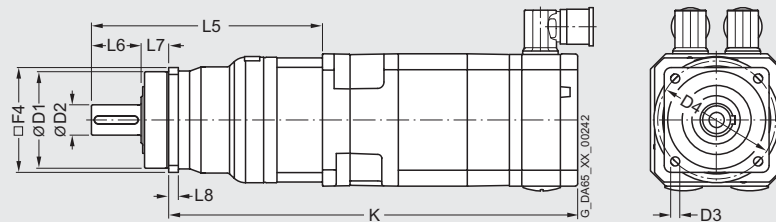

AC motors

Dimension drawings - synchronous motors

1FT6 motors without/with DRIVE-CLiQ with SP+ planetary gearbox, single-stage

For motor		Dimensions in mm (in)										Resolver		Incremental encoder sin/cos 1 V _{pp} , Absolute encoder (EnDat)	
Shaft height	Type	F4	Planetary gearbox Type	D1	D2	D3	D4	L5	L6	L7	L8	without brake K	with brake K	without brake K	with brake K
1FT6 with SP+ planetary gearbox, single-stage, type IM B5, natural cooling, with connector, without/with brake															
100	1FT6102	182 (7.17)	SP180S-MF1	160 (6.30)	55 (2.17)	13.5 (0.53)	215 (8.47)	310 (12.21)	82 (3.23)	30 (1.18)	15 (0.59)	493 (19.42)	539 (21.24)	493 (19.42)	539 (21.24)
	1FT6105	182 (7.17)	SP180S-MF1	160 (6.30)	55 (2.17)	13.5 (0.53)	215 (8.47)	310 (12.21)	82 (3.23)	30 (1.18)	15 (0.59)	568 (22.38)	614 (24.19)	568 (22.38)	614 (24.19)
	1FT6105	212 (8.35)	SP210-MF1	180 (7.09)	75 (2.96)	17 (0.67)	250 (9.85)	350 (13.79)	105 (4.14)	38 (1.50)	17 (0.67)	577 (22.73)	623 (24.55)	577 (22.73)	623 (24.55)
	1FT6108	182 (7.17)	SP180S-MF1	160 (6.30)	55 (2.17)	13.5 (0.53)	215 (8.47)	310 (12.21)	82 (3.23)	30 (1.18)	15 (0.59)	668 (26.32)	714 (28.13)	668 (26.32)	714 (28.13)
	1FT6108	212 (8.35)	SP210-MF1	180 (7.09)	75 (2.96)	17 (0.67)	250 (9.85)	350 (13.79)	105 (4.14)	38 (1.50)	17 (0.67)	677 (26.67)	723 (28.49)	677 (26.67)	723 (28.49)
	132	1FT6132	212 (8.35)	SP210-MF1	180 (7.09)	75 (2.96)	17 (0.67)	250 (9.85)	350 (13.79)	105 (4.14)	38 (1.50)	17 (0.67)	630 (24.82)	680 (26.79)	630 (24.82)
1FT6134		212 (8.35)	SP210-MF1	180 (7.09)	75 (2.96)	17 (0.67)	250 (9.85)	350 (13.79)	105 (4.14)	38 (1.50)	17 (0.67)	680 (26.79)	730 (28.76)	680 (26.79)	730 (28.76)
1FT6134		242 (9.53)	SP240-MF1	200 (7.88)	85 (3.35)	17 (0.67)	290 (11.43)	436 (17.18)	130 (5.12)	40 (1.58)	20 (0.79)	739 (29.12)	789 (31.09)	739 (29.12)	789 (31.09)
1FT6136		212 (8.35)	SP210-MF1	180 (7.09)	75 (2.96)	17 (0.67)	250 (9.85)	350 (13.79)	105 (4.14)	38 (1.50)	17 (0.67)	730 (28.76)	780 (30.73)	730 (28.76)	780 (30.73)
1FT6136		242 (9.53)	SP240-MF1	200 (7.88)	85 (3.35)	17 (0.67)	290 (11.43)	436 (17.18)	130 (5.12)	40 (1.58)	20 (0.79)	789 (31.09)	839 (33.06)	789 (31.09)	839 (33.06)

1FT610.
1FT613.

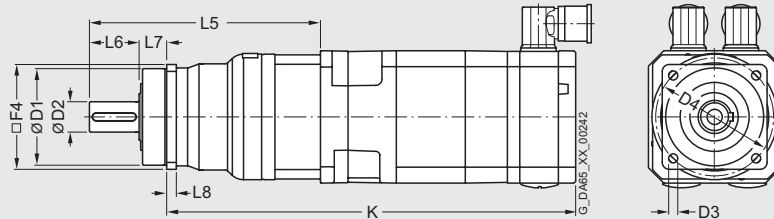

AC motors

Dimension drawings - synchronous motors

1FT6 motors without/with DRIVE-CLiQ with SP+ planetary gearbox, two-stage

For motor		Dimensions in mm (in)										Resolver		Incremental encoder sin/cos 1 V _{pp} Absolute encoder (EnDat)	
Shaft height	Type	F4	Planetary gearbox Type	D1	D2	D3	D4	L5	L6	L7	L8	without brake K	with brake K	without brake K	with brake K
				1FT6 with SP+ planetary gearbox, two-stage, type IM B5, natural cooling, with connector, without/with brake											
28	1FT6021	62 (2.44)	SP060S-MF2	60 (2.36)	16 (0.63)	5.5 (0.22)	68 (2.68)	156 (6.15)	28 (1.10)	20 (0.79)	6 (0.24)	301 (11.86)	326 (12.84)	301 (11.86)	326 (12.84)
	1FT6021	76 (2.99)	SP075S-MF2	70 (2.76)	22 (0.87)	6.6 (0.26)	85 (3.35)	175 (6.90)	36 (1.42)	20 (0.79)	7 (0.28)	312 (12.29)	337 (13.28)	312 (12.29)	337 (13.28)
	1FT6024	62 (2.44)	SP060S-MF2	60 (2.36)	16 (0.63)	5.5 (0.22)	68 (2.68)	156 (6.15)	28 (1.10)	20 (0.79)	6 (0.24)	341 (13.44)	366 (14.42)	341 (13.44)	366 (14.42)
	1FT6024	76 (2.99)	SP075S-MF2	70 (2.76)	22 (0.87)	6.6 (0.26)	85 (3.35)	175 (6.90)	36 (1.42)	20 (0.79)	7 (0.28)	352 (13.87)	377 (14.85)	352 (13.87)	377 (14.85)
	1FT6024	101 (3.98)	SP100S-MF2	90 (3.55)	32 (1.26)	9 (0.35)	120 (4.73)	230 (9.06)	58 (2.29)	30 (1.18)	10 (0.39)	375 (14.78)	400 (15.76)	375 (14.78)	400 (15.76)
	1FT6031	62 (2.44)	SP060S-MF2	60 (2.36)	16 (0.63)	5.5 (0.22)	68 (2.68)	164 (6.46)	28 (1.10)	20 (0.79)	6 (0.24)	296 (11.66)	316 (12.45)	336 (13.24)	356 (14.03)
36	1FT6031	76 (2.99)	SP075S-MF2	70 (2.76)	22 (0.87)	6.6 (0.26)	85 (3.35)	179 (7.05)	36 (1.42)	20 (0.79)	7 (0.28)	303 (11.94)	323 (12.73)	343 (13.51)	363 (14.30)
	1FT6031	101 (3.98)	SP100S-MF2	90 (3.55)	32 (1.26)	9 (0.35)	120 (4.73)	230 (9.06)	58 (2.29)	30 (1.18)	10 (0.39)	322 (12.69)	342 (13.47)	362 (14.26)	382 (15.05)
	1FT6034	76 (2.99)	SP075S-MF2	70 (2.76)	22 (0.87)	6.6 (0.26)	85 (3.35)	179 (7.05)	36 (1.42)	20 (0.79)	7 (0.28)	343 (13.51)	363 (14.30)	383 (15.09)	403 (15.88)
	1FT6034	101 (3.98)	SP100S-MF2	90 (3.55)	32 (1.26)	9 (0.35)	120 (4.73)	230 (9.06)	58 (2.29)	30 (1.18)	10 (0.39)	362 (14.26)	382 (15.05)	402 (15.84)	422 (16.63)
	1FT6034	141 (5.56)	SP140S-MF2	130 (5.12)	40 (1.58)	11 (0.43)	165 (6.50)	298 (11.74)	82 (3.23)	30 (1.18)	12 (0.47)	406 (16.00)	426 (16.78)	446 (17.57)	466 (18.36)
	1FT6041	76 (2.99)	SP075S-MF2	70 (2.76)	22 (0.87)	6.6 (0.26)	85 (3.35)	192 (7.56)	36 (1.42)	20 (0.79)	7 (0.28)	321 (12.65)	356 (14.03)	364 (14.34)	399 (15.72)
48	1FT6041	101 (3.98)	SP100S-MF2	90 (3.55)	32 (1.26)	9 (0.35)	120 (4.73)	234 (9.22)	58 (2.29)	30 (1.18)	10 (0.39)	331 (13.04)	366 (14.42)	374 (14.74)	409 (16.11)
	1FT6041	141 (5.56)	SP140S-MF2	130 (5.12)	40 (1.58)	11 (0.43)	165 (6.50)	298 (11.74)	82 (3.23)	30 (1.18)	12 (0.47)	371 (14.62)	406 (16.00)	414 (16.31)	449 (17.69)
	1FT6044	101 (3.98)	SP100S-MF2	90 (3.55)	32 (1.26)	9 (0.35)	120 (4.73)	234 (9.22)	58 (2.29)	30 (1.18)	10 (0.39)	381 (15.01)	416 (16.39)	424 (16.71)	459 (18.08)
	1FT6044	141 (5.56)	SP140S-MF2	130 (5.12)	40 (1.58)	11 (0.43)	165 (6.50)	298 (11.74)	82 (3.23)	30 (1.18)	12 (0.47)	421 (16.59)	456 (17.97)	464 (18.28)	499 (19.66)
	1FT6044	182 (7.17)	SP180S-MF2	160 (6.30)	55 (2.17)	13.5 (0.53)	215 (8.47)	346 (13.63)	82 (3.23)	30 (1.18)	15 (0.59)	469 (18.48)	504 (19.86)	512 (20.17)	547 (21.55)

**1FT602.
1FT603.
1FT604.**

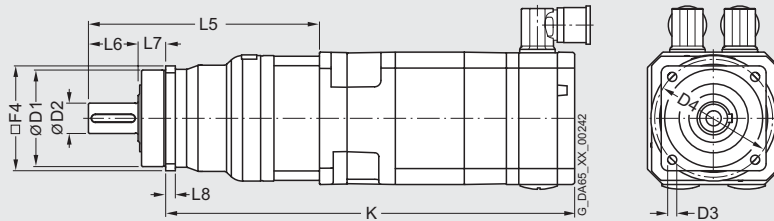

AC motors

Dimension drawings - synchronous motors

**1FT6 motors without/with DRIVE-CLiQ
with SP+ planetary gearbox, two-stage**

For motor		Dimensions in mm (in)										Resolver		Incremental encoder sin/cos 1 V _{pp} , Absolute encoder (EnDat)		
Shaft height	Type	F4	Planetary gearbox Type	D1	D2	D3	D4	L5	L6	L7	L8	without brake	with brake	without brake	with brake	
												K	K	K	K	
1FT6 with SP+ planetary gearbox, two-stage, type IM B5, natural cooling, with connector, without/with brake																
63	1FT6061	101	SP100S-MF2	90	32	9	120	252	58	30	10	362	392	392	422	
		(3.98)		(3.55)	(1.26)	(0.35)	(4.73)	(9.93)	(2.29)	(1.18)	(0.39)	(14.26)	(15.44)	(15.44)	(16.63)	
		1FT6061	141	SP140S-MF2	130	40	11	165	305	82	30	12	391	421	421	451
	(5.56)		(5.12)	(1.58)	(0.43)	(6.50)	(12.02)	(3.23)	(1.18)	(0.47)	(15.41)	(16.59)	(16.59)	(17.77)		
	1FT6061	182	SP180S-MF2	160	55	13.5	215	346	82	30	15	432	462	462	492	
	(7.17)		(6.30)	(2.17)	(0.53)	(8.47)	(13.63)	(3.23)	(1.18)	(0.59)	(17.02)	(18.20)	(18.20)	(19.38)		
	1FT6062	101	SP100S-MF2	90	32	9	120	252	58	30	10	387	417	417	447	
	(3.98)		(3.55)	(1.26)	(0.35)	(4.73)	(9.93)	(2.29)	(1.18)	(0.39)	(15.25)	(16.43)	(16.43)	(17.61)		
	1FT6062	141	SP140S-MF2	130	40	11	165	305	82	30	12	416	446	446	476	
(5.56)		(5.12)	(1.58)	(0.43)	(6.50)	(12.02)	(3.23)	(1.18)	(0.47)	(16.39)	(17.57)	(17.57)	(18.75)			
1FT6064	101	SP100S-MF2	90	32	9	120	252	58	30	10	437	467	467	497		
(3.98)		(3.55)	(1.26)	(0.35)	(4.73)	(9.93)	(2.29)	(1.18)	(0.39)	(17.22)	(18.40)	(18.40)	(19.58)			
1FT6064	141	SP140S-MF2	130	40	11	165	305	82	30	12	466	496	496	526		
(5.56)		(5.12)	(1.58)	(0.43)	(6.50)	(12.02)	(3.23)	(1.18)	(0.47)	(18.36)	(19.54)	(19.54)	(20.72)			
1FT6064	182	SP180S-MF2	160	55	13.5	215	346	82	30	15	507	537	537	567		
(7.17)		(6.30)	(2.17)	(0.53)	(8.47)	(13.63)	(3.23)	(1.18)	(0.59)	(19.98)	(21.16)	(21.16)	(22.34)			
80	1FT6081	141	SP140S-MF2	130	40	11	165	332	82	30	12	441	468	441	468	
	(5.56)		(5.12)	(1.58)	(0.43)	(6.50)	(13.08)	(3.23)	(1.18)	(0.47)	(17.38)	(18.44)	(17.38)	(18.44)		
	1FT6081	182	SP180S-MF2	160	55	13.5	215	355	82	30	15	464	491	464	491	
	(7.17)		(6.30)	(2.17)	(0.53)	(8.47)	(13.99)	(3.23)	(1.18)	(0.59)	(18.28)	(19.35)	(18.28)	(19.35)		
	1FT6081	212	SP210-MF2	180	75	17	250	397	105	38	17	475	502	475	502	
	(8.35)		(7.09)	(2.96)	(0.67)	(9.85)	(15.64)	(4.14)	(1.50)	(0.67)	(18.72)	(19.78)	(18.72)	(19.78)		
	1FT6082	141	SP140S-MF2	130	40	11	165	332	82	30	12	466	493	466	493	
	(5.56)		(5.12)	(1.58)	(0.43)	(6.50)	(13.08)	(3.23)	(1.18)	(0.47)	(18.36)	(19.42)	(18.36)	(19.42)		
	1FT6082	182	SP180S-MF2	160	55	13.5	215	355	82	30	15	489	516	489	516	
	(7.17)		(6.30)	(2.17)	(0.53)	(8.47)	(13.99)	(3.23)	(1.18)	(0.59)	(19.27)	(20.33)	(19.27)	(20.33)		
	1FT6082	212	SP210-MF2	180	75	17	250	397	105	38	17	500	527	500	527	
	(8.35)		(7.09)	(2.96)	(0.67)	(9.85)	(15.64)	(4.14)	(1.50)	(0.67)	(19.70)	(20.76)	(19.70)	(20.76)		
1FT6084	141	SP140S-MF2	130	40	11	165	332	82	30	12	516	562	516	562		
(5.56)		(5.12)	(1.58)	(0.43)	(6.50)	(13.08)	(3.23)	(1.18)	(0.47)	(20.33)	(22.14)	(20.33)	(22.14)			
1FT6084	182	SP180S-MF2	160	55	13.5	215	355	82	30	15	539	585	539	585		
(7.17)		(6.30)	(2.17)	(0.53)	(8.47)	(13.99)	(3.23)	(1.18)	(0.59)	(21.24)	(23.05)	(21.24)	(23.05)			
1FT6084	242	SP240-MF2	200	85	17	290	454	130	40	20	580	626	580	626		
(9.53)		(7.88)	(3.35)	(0.67)	(11.43)	(17.89)	(5.12)	(1.58)	(0.79)	(22.85)	(24.66)	(22.85)	(24.66)			
1FT6086	141	SP140S-MF2	130	40	11	165	332	82	30	12	566	612	566	612		
(5.56)		(5.12)	(1.58)	(0.43)	(6.50)	(13.08)	(3.23)	(1.18)	(0.47)	(22.30)	(24.11)	(22.30)	(24.11)			
1FT6086	182	SP180S-MF2	160	55	13.5	215	355	82	30	15	589	635	589	635		
(7.17)		(6.30)	(2.17)	(0.53)	(8.47)	(13.99)	(3.23)	(1.18)	(0.59)	(23.21)	(25.02)	(23.21)	(25.02)			

**1FT606.
1FT608.**

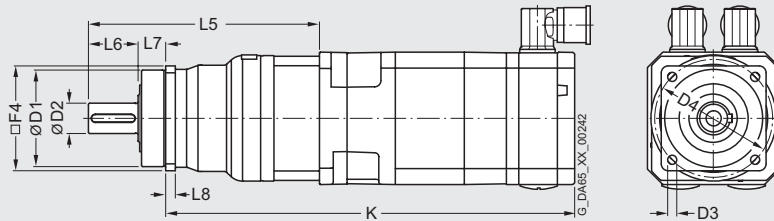

AC motors

Dimension drawings - synchronous motors

1FT6 motors without/with DRIVE-CLiQ with SP+ planetary gearbox, two-stage

For motor		Dimensions in mm (in)										Resolver		Incremental encoder sin/cos 1 V _{pp} , Absolute encoder (EnDat)	
Shaft height	Type	F4	Planetary gearbox Type	D1	D2	D3	D4	L5	L6	L7	L8	without brake	with brake	without brake	with brake
												K	K	K	K
1FT6 with SP+ planetary gearbox, two-stage, type IM B5, natural cooling, with connector, without/with brake															
100	1FT6102	182 (7.17)	SP180S-MF2	160 (6.30)	55 (2.17)	13.5 (0.53)	215 (8.47)	355 (13.99)	82 (3.23)	30 (1.18)	15 (0.59)	538 (21.20)	584 (23.01)	538 (21.20)	584 (23.01)
	1FT6102	242 (9.53)	SP240-MF2	200 (7.88)	85 (3.35)	17 (0.67)	290 (11.43)	454 (17.89)	130 (5.12)	40 (1.58)	20 (0.79)	579 (22.81)	625 (24.63)	579 (22.81)	625 (24.63)
	1FT6105	212 (8.35)	SP210-MF2	180 (7.09)	75 (2.96)	17 (0.67)	250 (9.85)	397 (15.64)	105 (4.14)	38 (1.50)	17 (0.67)	624 (24.59)	670 (26.40)	624 (24.59)	670 (26.40)
	1FT6105	242 (9.53)	SP240-MF2	200 (7.88)	85 (3.35)	17 (0.67)	290 (11.43)	454 (17.89)	130 (5.12)	40 (1.58)	20 (0.79)	654 (25.77)	700 (27.58)	654 (25.77)	700 (27.58)
	1FT6108	242 (9.53)	SP240-MF2	200 (7.88)	85 (3.35)	17 (0.67)	290 (11.43)	454 (17.89)	130 (5.12)	40 (1.58)	20 (0.79)	754 (29.71)	800 (31.52)	754 (29.71)	800 (31.52)
	1FT6132	212 (8.35)	SP210-MF2	180 (7.09)	75 (2.96)	17 (0.67)	250 (9.85)	397 (15.64)	105 (4.14)	38 (1.50)	170 (6.70)	677 (26.67)	727 (28.64)	677 (26.67)	727 (28.64)
132	1FT6134	242 (9.53)	SP240-MF2	200 (7.88)	85 (3.35)	17 (0.67)	290 (11.43)	454 (17.89)	130 (5.12)	40 (1.58)	20 (0.79)	757 (29.83)	807 (31.80)	757 (29.83)	807 (31.80)
	1FT6136	242 (9.53)	SP240-MF2	200 (7.88)	85 (3.35)	17 (0.67)	290 (11.43)	454 (17.89)	130 (5.12)	40 (1.58)	20 (0.79)	807 (31.80)	857 (33.77)	807 (31.80)	857 (33.77)

1FT610.
1FT613.

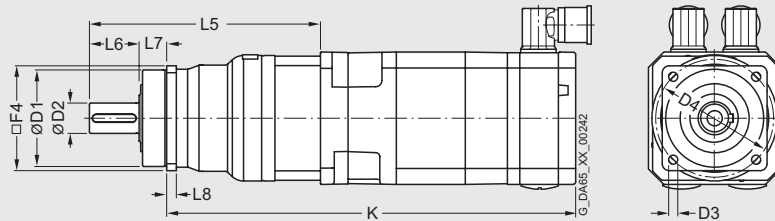

AC motors

Dimension drawings - synchronous motors

1FK7 Compact motors without/with DRIVE-CLiQ with SP+ planetary gearbox, single-stage

For motor		Dimensions in mm (in)										Resolver		Incremental encoder sin/cos 1 V _{pp} , Basic absolute encoder (EnDat) ¹⁾		Absolute encoder (EnDat)		
Shaft height	Type	F4	Planetary gearbox Type	D1	D2	D3	D4	L5	L6	L7	L8	without brake	with brake	without brake	with brake	without brake	with brake	
												K	K	K	K	K	K	
1FK7 Compact with SP+ planetary gearbox, single-stage, type IM B5, natural cooling, with connector, without/with brake																		
28	1FK7022-5	62 (2.44)	SP060S-MF1	60 (2.36)	16 (0.63)	6 (0.24)	68 (2.68)	137 (5.40)	28 (1.10)	20 (0.79)	6 (0.24)	242 (9.53)	264 (10.40)	267 (10.52)	289 (11.39)	267 (10.52)	289 (11.39)	
36	1FK7032-5	62 (2.44)	SP060S-MF1	60 (2.36)	16 (0.63)	6 (0.24)	68 (2.68)	142 (5.59)	28 (1.10)	20 (0.79)	6 (0.24)	244 (9.61)	269 (10.60)	269 (10.60)	294 (11.58)	269 (10.60)	294 (11.58)	
48	1FK7040-5	76 (2.99)	SP075S-MF1	70 (2.76)	22 (0.87)	7 (0.28)	85 (3.35)	168 (6.62)	36 (1.42)	20 (0.79)	7 (0.28)	246 (9.69)	275 (10.84)	267 (10.52)	296 (11.66)	275 (10.84)	304 (11.98)	
	1FK7042-5	76 (2.99)	SP075S-MF1	70 (2.76)	22 (0.87)	7 (0.28)	85 (3.35)	168 (6.62)	36 (1.42)	20 (0.79)	7 (0.28)	274 (10.80)	303 (11.94)	294 (11.58)	323 (12.73)	303 (11.94)	332 (13.08)	
63	1FK7060-5	101 (3.98)	SP100S-MF1	90 (3.55)	32 (1.26)	9 (0.35)	120 (4.73)	217 (8.55)	58 (2.29)	30 (1.18)	10 (0.39)	286 (11.27)	329 (12.96)	309 (12.17)	352 (13.87)	317 (12.49)	360 (14.18)	
	1FK7063-5	101 (3.98)	SP100S-MF1	90 (3.55)	32 (1.26)	9 (0.35)	120 (4.73)	217 (8.55)	58 (2.29)	30 (1.18)	10 (0.39)	331 (13.04)	374 (14.74)	354 (13.95)	397 (15.64)	362 (14.26)	405 (15.96)	
80	1FK7080-5	141 (5.56)	SP140S-MF1	130 (5.12)	40 (1.58)	11 (0.43)	165 (6.50)	283 (11.15)	82 (3.23)	30 (1.18)	12 (0.47)	327 (12.88)	355 (13.99)	350 (13.79)	377 (14.85)	358 (14.11)	386 (15.21)	
	1FK7083-5	141 (5.56)	SP140S-MF1	130 (5.12)	40 (1.58)	11 (0.43)	165 (6.50)	283 (11.15)	82 (3.23)	30 (1.18)	12 (0.47)	365 (14.38)	416 (16.39)	388 (15.29)	439 (17.30)	396 (15.60)	447 (17.61)	
100	1FK7100-5	182 (7.17)	SP180S-MF1	160 (6.30)	55 (2.17)	14 (0.55)	215 (8.47)	310 (12.21)	82 (3.23)	30 (1.18)	15 (0.59)	383 (15.09)	402 (15.84)	406 (16.00)	425 (16.75)	414 (16.31)	433 (17.06)	
	1FK7101-5	182 (7.17)	SP180S-MF1	160 (6.30)	55 (2.17)	14 (0.55)	215 (8.47)	310 (12.21)	82 (3.23)	30 (1.18)	15 (0.59)	409 (16.11)	438 (17.26)	432 (17.02)	461 (18.16)	440 (17.34)	469 (18.48)	
	1FK7103-5	182 (7.17)	SP180S-MF1	160 (6.30)	55 (2.17)	14 (0.55)	215 (8.47)	310 (12.21)	82 (3.23)	30 (1.18)	15 (0.59)	435 (17.14)	464 (18.28)	458 (18.05)	487 (19.19)	466 (18.36)	495 (19.50)	
	1FK7105-5	182 (7.17)	SP180S-MF1	160 (6.30)	55 (2.17)	14 (0.55)	215 (8.47)	310 (12.21)	82 (3.23)	30 (1.18)	15 (0.59)	487 (19.19)	516 (20.33)	510 (20.09)	539 (21.24)	518 (20.41)	547 (21.55)	
	1FK7105-5	212 (8.35)	SP210-MF1	180 (7.09)	75 (2.96)	17 (0.67)	250 (9.85)	350 (13.79)	105 (4.14)	38 (1.50)	17 (0.67)	496 (19.54)	525 (20.69)	519 (20.45)	548 (21.59)	527 (20.76)	556 (21.91)	

1FK702.-5
1FK703.-5
1FK704.-5
1FK706.-5
1FK708.-5
1FK710.-5

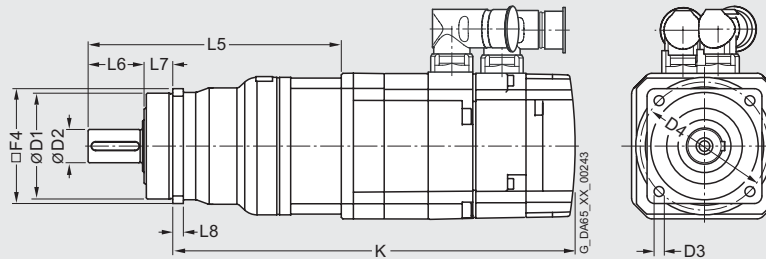

¹⁾ 1FK022 and 1FK7032 motors cannot be supplied with basic absolute encoders.

AC motors

Dimension drawings - synchronous motors

1FK7 High Dynamic motors without/with DRIVE-CLiQ with SP+ planetary gearbox, single-stage

For motor		Dimensions in mm (in)											Resolver		Incremental encoder sin/cos 1 V _{pp} , Basic absolute encoder (EnDat) ¹⁾		Absolute encoder (EnDat)	
Shaft height	Type	F4	Planetary gearbox Type	D1	D2	D3	D4	L5	L6	L7	L8	without brake	with brake	without brake	with brake	without brake	with brake	
												K	K	K	K	K	K	
1FK7 High Dynamic with SP+ planetary gearbox, single-stage, type IM B5, natural cooling, with connector, without/with brake																		
36	1FK7033-7	62 (2.44)	SP060S-MF1	60 (2.36)	16 (0.63)	6 (0.24)	68 (2.68)	142 (5.59)	28 (1.10)	20 (0.79)	6 (0.24)	263 (10.36)	288 (11.35)	288 (11.35)	313 (12.33)	288 (11.35)	313 (12.33)	
48	1FK7043-7	76 (2.99)	SP075S-MF1	70 (2.76)	22 (0.87)	7 (0.28)	85 (3.35)	168 (6.62)	36 (1.42)	20 (0.79)	7 (0.28)	303 (11.94)	332 (13.08)	324 (12.77)	353 (13.91)	332 (13.08)	361 (14.22)	
	1FK7044-7	76 (2.99)	SP075S-MF1	70 (2.76)	22 (0.87)	7 (0.28)	85 (3.35)	168 (6.62)	36 (1.42)	20 (0.79)	7 (0.28)	328 (12.92)	357 (14.07)	349 (13.75)	378 (14.89)	357 (14.07)	386 (15.21)	
63	1FK7061-7	101 (3.98)	SP100S-MF1	90 (3.55)	32 (1.26)	9 (0.35)	120 (4.73)	217 (8.55)	58 (2.29)	30 (1.18)	10 (0.39)	314 (12.37)	357 (14.07)	337 (13.28)	380 (14.97)	346 (13.63)	389 (15.33)	
	1FK7064-7	101 (3.98)	SP100S-MF1	90 (3.55)	32 (1.26)	9 (0.35)	120 (4.73)	217 (8.55)	58 (2.29)	30 (1.18)	10 (0.39)	378 (14.89)	421 (16.59)	401 (15.80)	444 (17.49)	410 (16.15)	453 (17.85)	
80	1FK7085-7	141 (5.56)	SP140S-MF1	130 (5.12)	40 (1.58)	11 (0.43)	165 (6.50)	283 (11.15)	82 (3.23)	30 (1.18)	12 (0.47)	432 (17.02)	474 (18.68)	454 (17.89)	497 (19.58)	463 (18.24)	505 (19.90)	
	1FK7086-7	141 (5.56)	SP140S-MF1	130 (5.12)	40 (1.58)	11 (0.43)	165 (6.50)	283 (11.15)	82 (3.23)	30 (1.18)	12 (0.47)	432 (17.02)	474 (18.68)	454 (17.89)	497 (19.58)	463 (18.24)	505 (19.90)	

**1FK703.-7
1FK704.-7
1FK706.-7
1FK708.-7**

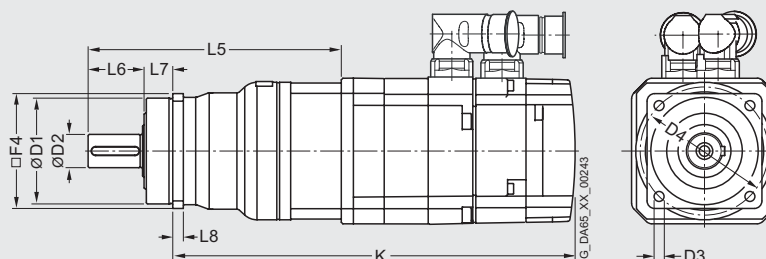

¹⁾ The 1FK7033 motor cannot be supplied with a basic absolute encoder.



AC motors

Dimension drawings - synchronous motors

1FK7 Compact motors without/with DRIVE-CLIQ with SP+ planetary gearbox, two-stage

For motor		Dimensions in mm (in)										Resolver		Incremental encoder sin/cos 1 V _{pp} , Basic absolute encoder (EnDat) ¹⁾		Absolute encoder (EnDat)		
Shaft height	Type	F4	Planetary gearbox Type	D1	D2	D3	D4	L5	L6	L7	L8	without brake	with brake	without brake	with brake	without brake	with brake	
												K	K	K	K	K	K	
1FK7 Compact with SP+ planetary gearbox, two-stage, type IM B5, natural cooling, with connector, without/with brake																		
28	1FK7022-5	62 (2.44)	SP060S-MF2	60 (2.36)	16 (0.63)	5.5 (0.22)	68 (2.68)	156 (6.15)	28 (1.10)	20 (0.79)	6 (0.24)	261 (10.28)	283 (11.15)	286 (11.27)	308 (12.14)	286 (11.27)	308 (12.14)	
	1FK7022-5	76 (2.99)	SP075S-MF2	70 (2.76)	22 (0.87)	6.6 (0.26)	85 (3.35)	175 (6.90)	36 (1.42)	20 (0.79)	7 (0.28)	272 (10.72)	294 (11.58)	297 (11.70)	319 (12.57)	297 (11.70)	319 (12.57)	
	1FK7022-5	101 (3.98)	SP100S-MF2	90 (3.55)	32 (1.26)	9 (0.35)	120 (4.73)	230 (9.06)	58 (2.29)	30 (1.18)	10 (0.39)	295 (11.62)	317 (12.49)	320 (12.61)	342 (13.47)	320 (12.61)	342 (13.47)	
36	1FK7032-5	62 (2.44)	SP060S-MF2	60 (2.36)	16 (0.63)	5.5 (0.22)	68 (2.68)	164 (6.46)	28 (1.10)	20 (0.79)	6 (0.24)	266 (10.48)	291 (11.47)	291 (11.47)	316 (12.45)	291 (11.47)	316 (12.45)	
	1FK7032-5	76 (2.99)	SP075S-MF2	70 (2.76)	22 (0.87)	6.6 (0.26)	85 (3.35)	179 (7.05)	36 (1.42)	20 (0.79)	7 (0.28)	273 (10.76)	298 (11.74)	298 (11.74)	323 (12.73)	298 (11.74)	323 (12.73)	
	1FK7032-5	101 (3.98)	SP100S-MF2	90 (3.55)	32 (1.26)	9 (0.35)	120 (4.73)	230 (9.06)	58 (2.29)	30 (1.18)	10 (0.39)	292 (11.50)	317 (12.49)	317 (12.49)	342 (13.47)	317 (12.49)	342 (13.47)	
48	1FK7040-5	76 (2.99)	SP075S-MF2	70 (2.76)	22 (0.87)	6.6 (0.26)	85 (3.35)	192 (7.56)	36 (1.42)	20 (0.79)	7 (0.28)	270 (10.64)	299 (11.78)	291 (11.47)	320 (12.61)	299 (11.78)	328 (12.92)	
	1FK7040-5	101 (3.98)	SP100S-MF2	90 (3.55)	32 (1.26)	9 (0.35)	120 (4.73)	234 (9.22)	58 (2.29)	30 (1.18)	10 (0.39)	280 (11.03)	309 (12.17)	301 (11.86)	330 (13.00)	309 (12.17)	338 (13.32)	
	1FK7040-5	141 (5.56)	SP140S-MF2	130 (5.12)	40 (1.58)	11 (0.43)	165 (6.50)	298 (11.74)	82 (3.23)	30 (1.18)	12 (0.47)	320 (12.61)	349 (13.75)	341 (13.44)	370 (14.58)	349 (13.75)	378 (14.89)	
	1FK7042-5	76 (2.99)	SP075S-MF2	70 (2.76)	22 (0.87)	6.6 (0.26)	85 (3.35)	192 (7.56)	36 (1.42)	20 (0.79)	7 (0.28)	298 (11.74)	327 (12.88)	298 (11.74)	347 (13.67)	327 (12.88)	356 (14.03)	
	1FK7042-5	101 (3.98)	SP100S-MF2	90 (3.55)	32 (1.26)	9 (0.35)	120 (4.73)	234 (9.22)	58 (2.29)	30 (1.18)	10 (0.39)	308 (12.14)	337 (13.28)	308 (12.14)	357 (14.07)	337 (13.28)	366 (14.42)	
	1FK7042-5	141 (5.56)	SP140S-MF2	130 (5.12)	40 (1.58)	11 (0.43)	165 (6.50)	298 (11.74)	82 (3.23)	30 (1.18)	12 (0.47)	348 (13.71)	377 (14.85)	368 (14.50)	397 (15.64)	377 (14.85)	406 (16.00)	
63	1FK7060-5	101 (3.98)	SP100S-MF2	90 (3.55)	32 (1.26)	9 (0.35)	120 (4.73)	252 (9.93)	58 (2.29)	30 (1.18)	10 (0.39)	321 (12.65)	364 (14.34)	344 (13.55)	387 (15.25)	352 (13.87)	395 (15.56)	
	1FK7060-5	141 (5.56)	SP140S-MF2	130 (5.12)	40 (1.58)	11 (0.43)	165 (6.50)	305 (12.02)	82 (3.23)	30 (1.18)	12 (0.47)	350 (13.79)	393 (15.48)	373 (14.70)	416 (16.39)	381 (15.01)	424 (16.71)	
	1FK7063-5	141 (5.56)	SP140S-MF2	130 (5.12)	40 (1.58)	11 (0.43)	165 (6.50)	305 (12.02)	82 (3.23)	30 (1.18)	12 (0.47)	395 (15.56)	438 (17.26)	418 (16.47)	461 (18.16)	426 (16.78)	469 (18.48)	
	1FK7063-5	182 (7.17)	SP180S-MF2	160 (6.30)	55 (2.17)	13.5 (0.53)	215 (8.47)	346 (13.63)	82 (3.23)	30 (1.18)	15 (0.59)	436 (17.18)	479 (18.87)	459 (18.08)	502 (19.78)	467 (18.40)	510 (20.09)	

1FK702.-5
1FK703.-5
1FK704.-5
1FK706.-5

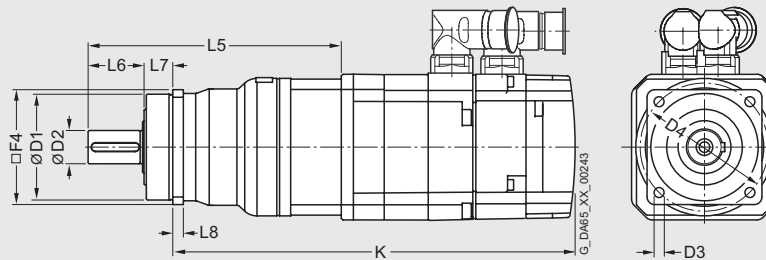

¹⁾ 1FK7022 and 1FK7032 motors cannot be supplied with a basic absolute encoder.

AC motors

Dimension drawings - synchronous motors

1FK7 Compact motors without/with DRIVE-CLiQ with SP+ planetary gearbox, two-stage

For motor		Dimensions in mm (in)										Resolver		Incremental encoder sin/cos 1 V _{pp} , Basic absolute encoder (EnDat) ¹⁾		Absolute encoder (EnDat)	
Shaft height	Type	F4	Planetary gearbox Type	D1	D2	D3	D4	L5	L6	L7	L8	without brake K	with brake K	without brake K	with brake K	without brake K	with brake K
1FK7 Compact with SP+ planetary gearbox, two-stage, type IM B5, natural cooling, with connector, without/with brake																	
80	1FK7080-5	141	SP140S-MF2	130	40	11	165	332	82	30	12	376	404	399	426	407	435
		(5.56)		(5.12)	(1.58)	(0.43)	(6.50)	(13.08)	(3.23)	(1.18)	(0.47)	(14.81)	(15.92)	(15.72)	(16.78)	(16.04)	(17.14)
	1FK7080-5	182	SP180S-MF2	160	55	13.5	215	355	82	30	15	399	427	422	449	430	458
		(7.17)		(6.30)	(2.17)	(0.53)	(8.47)	(13.99)	(3.23)	(1.18)	(0.59)	(15.72)	(16.82)	(16.63)	(17.69)	(16.94)	(18.05)
	1FK7080-5	212	SP210-MF2	180	75	17	250	397	105	38	17	410	438	433	460	441	469
		(8.35)		(7.09)	(2.96)	(0.67)	(9.85)	(15.64)	(4.14)	(1.50)	(0.67)	(16.15)	(17.26)	(17.06)	(18.12)	(17.38)	(18.48)
	1FK7083-5	141	SP140S-MF2	130	40	11	165	332	82	30	12	414	465	437	488	445	496
		(5.56)		(5.12)	(1.58)	(0.43)	(6.50)	(13.08)	(3.23)	(1.18)	(0.47)	(16.31)	(18.32)	(17.22)	(19.23)	(17.53)	(19.54)
	1FK7083-5	182	SP180S-MF2	160	55	13.5	215	355	82	30	15	437	488	460	511	468	519
		(7.17)		(6.30)	(2.17)	(0.53)	(8.47)	(13.99)	(3.23)	(1.18)	(0.59)	(17.22)	(19.23)	(18.12)	(20.13)	(18.44)	(20.45)
	1FK7083-5	212	SP210-MF2	180	75	17	250	397	105	38	17	448	499	471	522	479	530
		(8.35)		(7.09)	(2.96)	(0.67)	(9.85)	(15.64)	(4.14)	(1.50)	(0.67)	(17.65)	(19.66)	(18.56)	(20.57)	(18.87)	(20.88)
100	1FK7100-5	182	SP180S-MF2	160	55	13.5	215	310	82	30	15	383	402	406	425	414	433
		(7.17)		(6.30)	(2.17)	(0.53)	(8.47)	(12.21)	(3.23)	(1.18)	(0.59)	(15.09)	(15.84)	(16.00)	(16.75)	(16.31)	(17.06)
	1FK7100-5	212	SP210-MF2	180	75	17	250	397	105	38	17	439	458	462	481	470	489
		(8.35)		(7.09)	(2.96)	(0.67)	(9.85)	(15.64)	(4.14)	(1.50)	(0.67)	(17.30)	(18.05)	(18.20)	(18.95)	(18.52)	(19.27)
	1FK7101-5	182	SP180S-MF2	160	55	13.5	215	310	82	30	15	409	438	432	461	440	469
		(7.17)		(6.30)	(2.17)	(0.53)	(8.47)	(12.21)	(3.23)	(1.18)	(0.59)	(16.11)	(17.26)	(17.02)	(18.16)	(17.34)	(18.48)
	1FK7101-5	212	SP210-MF2	180	75	17	250	397	105	38	17	465	494	488	517	496	525
		(8.35)		(7.09)	(2.96)	(0.67)	(9.85)	(15.64)	(4.14)	(1.50)	(0.67)	(18.32)	(19.46)	(19.23)	(20.37)	(19.54)	(20.69)
	1FK7101-5	242	SP240-MF2	200	85	17	290	454	130	40	20	495	524	518	547	526	555
		(9.53)		(7.88)	(3.35)	(0.67)	(11.43)	(17.89)	(5.12)	(1.58)	(0.79)	(19.50)	(20.65)	(20.41)	(21.55)	(20.72)	(21.87)
	1FK7103-5	182	SP180S-MF2	160	55	13.5	215	310	82	30	15	435	464	458	487	466	495
		(7.17)		(6.30)	(2.17)	(0.53)	(8.47)	(12.21)	(3.23)	(1.18)	(0.59)	(17.14)	(18.28)	(18.05)	(19.19)	(18.36)	(19.50)
1FK7103-5	212	SP210-MF2	180	75	17	250	397	105	38	17	491	520	514	543	522	551	
	(8.35)		(7.09)	(2.96)	(0.67)	(9.85)	(15.64)	(4.14)	(1.50)	(0.67)	(19.35)	(20.49)	(20.25)	(21.39)	(20.57)	(21.71)	
1FK7103-5	242	SP240-MF2	200	85	17	290	454	130	40	20	521	550	544	573	552	581	
	(9.53)		(7.88)	(3.35)	(0.67)	(11.43)	(17.89)	(5.12)	(1.58)	(0.79)	(20.53)	(21.67)	(21.43)	(22.58)	(21.75)	(22.89)	
1FK7105-5	212	SP210-MF2	180	75	17	250	397	105	38	17	543	572	566	595	574	603	
	(8.35)		(7.09)	(2.96)	(0.67)	(9.85)	(15.64)	(4.14)	(1.50)	(0.67)	(21.39)	(22.54)	(22.30)	(23.44)	(22.62)	(23.76)	
1FK7105-5	242	SP240-MF2	200	85	17	290	454	130	40	20	573	602	596	625	604	633	
	(9.53)		(7.88)	(3.35)	(0.67)	(11.43)	(17.89)	(5.12)	(1.58)	(0.79)	(22.58)	(23.72)	(23.48)	(24.63)	(23.80)	(24.94)	

1FK708.-5
1FK710.-5

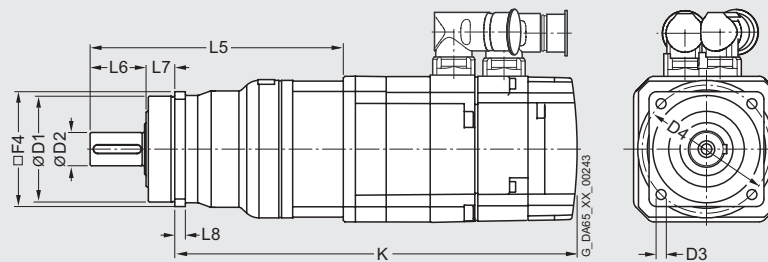

3

AC motors

Dimension drawings - synchronous motors

1FK7 High Dynamic motors without/with DRIVE-CLiQ with SP+ planetary gearbox, two-stage

For motor		Dimensions in mm (in)										Resolver		Incremental encoder sin/cos 1 V _{pp} , Basic absolute encoder (EnDat) ¹⁾		Absolute encoder (EnDat)		
Shaft height	Type	F4	Planetary gearbox Type	D1	D2	D3	D4	L5	L6	L7	L8	without brake	with brake	without brake	with brake	without brake	with brake	
1FK7 High Dynamic with SP+ planetary gearbox, two-stage, type IM B5, natural cooling, with connector, without/with brake																		
36	1FK7033-7	62 (2.44)	SP060S-MF2	60 (2.36)	16 (0.63)	5.5 (0.22)	68 (2.68)	164 (6.46)	28 (1.10)	20 (0.79)	6 (0.24)	285 (11.23)	310 (12.21)	310 (12.21)	335 (13.20)	310 (12.21)	335 (13.20)	
	1FK7033-7	76 (2.99)	SP075S-MF2	70 (2.76)	22 (0.87)	6.6 (0.26)	85 (3.35)	179 (7.05)	36 (1.42)	20 (0.79)	7 (0.28)	292 (11.50)	317 (12.49)	317 (12.49)	342 (13.47)	317 (12.49)	342 (13.47)	
	1FK7033-7	101 (3.98)	SP100S-MF2	90 (3.55)	32 (1.26)	9 (0.35)	120 (4.73)	230 (9.06)	58 (2.29)	30 (1.18)	10 (0.39)	311 (12.25)	336 (13.24)	336 (13.24)	361 (14.22)	336 (13.24)	361 (14.22)	
48	1FK7043-7	76 (2.99)	SP075S-MF2	70 (2.76)	22 (0.87)	6.6 (0.26)	85 (3.35)	192 (7.56)	36 (1.42)	20 (0.79)	7 (0.28)	327 (12.88)	356 (14.03)	348 (13.71)	377 (14.85)	356 (14.03)	385 (15.17)	
	1FK7043-7	101 (3.98)	SP100S-MF2	90 (3.55)	32 (1.26)	9 (0.35)	120 (4.73)	234 (9.22)	58 (2.29)	30 (1.18)	10 (0.39)	337 (13.28)	366 (14.42)	358 (14.11)	387 (15.25)	366 (14.42)	395 (15.56)	
	1FK7043-7	141 (5.56)	SP140S-MF2	130 (5.12)	40 (1.58)	11 (0.43)	165 (6.50)	298 (11.74)	82 (3.23)	30 (1.18)	12 (0.47)	377 (14.85)	406 (16.00)	398 (15.68)	427 (16.82)	406 (16.00)	435 (17.14)	
	1FK7044-7	101 (3.98)	SP100S-MF2	90 (3.55)	32 (1.26)	9 (0.35)	120 (4.73)	234 (9.22)	58 (2.29)	30 (1.18)	10 (0.39)	362 (14.26)	391 (15.41)	383 (15.09)	412 (16.23)	391 (15.41)	420 (16.55)	
	1FK7044-7	141 (5.56)	SP140S-MF2	130 (5.12)	40 (1.58)	11 (0.43)	165 (6.50)	298 (11.74)	82 (3.23)	30 (1.18)	12 (0.47)	402 (15.84)	431 (16.98)	432 (17.02)	452 (17.81)	431 (16.98)	460 (18.12)	
63	1FK7061-7	101 (3.98)	SP100S-MF2	90 (3.55)	32 (1.26)	9 (0.35)	120 (4.73)	252 (9.93)	58 (2.29)	30 (1.18)	10 (0.39)	349 (13.75)	392 (15.44)	372 (14.66)	415 (16.35)	381 (15.01)	424 (16.71)	
	1FK7061-7	141 (5.56)	SP140S-MF2	130 (5.12)	40 (1.58)	11 (0.43)	165 (6.50)	305 (12.02)	82 (3.23)	30 (1.18)	12 (0.47)	378 (14.89)	421 (16.59)	401 (15.80)	444 (17.49)	410 (16.15)	453 (17.85)	
	1FK7064-7	141 (5.56)	SP140S-MF2	130 (5.12)	40 (1.58)	11 (0.43)	165 (6.50)	305 (12.02)	82 (3.23)	30 (1.18)	12 (0.47)	442 (17.41)	485 (19.11)	465 (18.32)	508 (20.02)	474 (18.68)	517 (20.37)	
80	1FK7085-7	182 (7.17)	SP180S-MF2	160 (6.30)	55 (2.17)	13.5 (0.53)	215 (8.47)	355 (13.99)	82 (3.23)	30 (1.18)	15 (0.59)	504 (19.84)	547 (21.54)	526 (20.71)	569 (22.40)	535 (21.06)	577 (22.72)	
	1FK7085-7	212 (8.35)	SP210-MF2	180 (7.09)	75 (2.96)	17 (0.67)	250 (9.85)	397 (15.64)	105 (4.14)	38 (1.50)	17 (0.67)	515 (20.29)	557 (21.95)	537 (21.16)	580 (22.85)	546 (21.51)	588 (23.17)	
	1FK7086-7	182 (7.17)	SP180S-MF2	160 (6.30)	55 (2.17)	13.5 (0.53)	215 (8.47)	355 (13.99)	82 (3.23)	30 (1.18)	15 (0.59)	504 (19.84)	547 (21.54)	526 (20.71)	569 (22.40)	535 (21.06)	577 (22.72)	
	1FK7086-7	212 (8.35)	SP210-MF2	180 (7.09)	75 (2.96)	17 (0.67)	250 (9.85)	397 (15.64)	105 (4.14)	38 (1.50)	17 (0.67)	515 (20.29)	557 (21.95)	537 (21.16)	580 (22.85)	546 (21.51)	588 (23.17)	

1FK703.-7
1FK704.-7
1FK706.-7
1FK708.-7

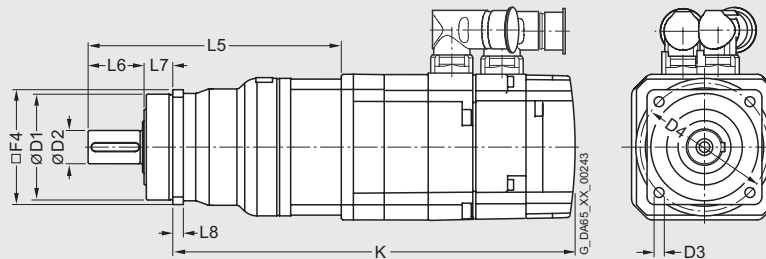

¹⁾ The 1FK7033 motor cannot be supplied with a basic absolute encoder.

AC motors

Dimension drawings - synchronous motors

1FK7 Compact motors without/with DRIVE-CLiQ with LP+ planetary gearbox, single-stage

For motor		Dimensions in mm (in)															
		Resolver						Basic absolute encoder (EnDat) ¹⁾ Incremental encoder sin/cos 1 V _{pp}				Absolute encoder (EnDat)					
		without brake			with brake			without brake		with brake		without brake		with brake			
Shaft height	Type	DIN IEC	k LB	K	k LB	K	k LB	K	k LB	K	k LB	K	k LB	K	l E	d D	a ₁ P
1FK7 Compact with LP+ planetary gearbox, single-stage, type IM B5, natural cooling, with connector, with/without brake																	
28	1FK7022-5		153 (6.02)	216 (8.50)	175 (6.89)	238 (9.37)	178 (7.01)	241 (9.49)	200 (7.87)	263 (10.35)	178 (7.01)	241 (9.49)	200 (7.87)	263 (10.35)	20 (0.79)	9 (0.35)	–
	1FK7022-5		153 (6.02)	236 (9.29)	175 (6.89)	258 (10.16)	178 (7.01)	261 (10.28)	200 (7.87)	283 (11.14)	178 (7.01)	261 (10.28)	200 (7.87)	283 (11.14)			
36	1FK7032-5		150 (5.91)	240 (9.45)	175 (6.89)	265 (10.43)	175 (6.89)	265 (10.43)	200 (7.87)	290 (11.42)	175 (6.89)	265 (10.43)	200 (7.87)	290 (11.42)	30 (1.18)	14 (0.55)	92 (3.62)
	1FK7034-5		175 (6.89)	265 (10.43)	200 (7.87)	290 (11.42)	200 (7.87)	290 (11.42)	225 (8.86)	315 (12.40)	200 (7.87)	290 (11.42)	225 (8.86)	315 (12.40)			
48	1FK7040-5		135 (5.31)	247 (9.72)	164 (6.46)	276 (10.87)	155 (6.10)	267 (10.51)	184 (7.24)	296 (11.65)	164 (6.46)	276 (10.87)	193 (7.60)	305 (12.01)	40 (1.57)	19 (0.75)	120 (4.72)
	1FK7042-5		162 (6.38)	274 (10.79)	191 (7.52)	303 (11.93)	183 (7.20)	295 (11.61)	212 (8.35)	324 (12.76)	191 (7.52)	303 (11.93)	220 (8.66)	332 (13.07)			
63	1FK7060-5		157 (6.18)	297 (11.69)	200 (7.87)	340 (13.39)	180 (7.09)	320 (12.60)	223 (8.78)	363 (14.29)	188 (7.40)	328 (12.91)	231 (9.09)	371 (14.61)	50 (1.97)	24 (0.94)	155 (6.10)
	1FK7063-5		202 (7.95)	342 (13.46)	245 (9.65)	385 (15.16)	225 (8.86)	365 (14.37)	268 (10.55)	408 (16.06)	233 (9.17)	373 (14.69)	276 (10.87)	416 (16.38)			
80	1FK7080-5		156 (6.14)	325 (12.80)	184 (7.24)	353 (13.90)	179 (7.05)	347 (13.66)	206 (8.11)	375 (14.76)	187 (7.36)	355 (13.98)	215 (8.46)	384 (15.12)	58 (2.28)	32 (1.26)	186 (7.32)
	1FK7083-5		194 (7.64)	363 (14.29)	245 (9.65)	414 (16.30)	217 (8.54)	385 (15.16)	268 (10.55)	436 (17.17)	225 (8.86)	393 (15.47)	276 (10.87)	444 (17.48)			

Shaft height	Type	Planetary gearbox Type	Planetary gearbox dimensions													
			D ₁	D ₂	D ₃	D ₄	D ₅	L ₂	L ₃	L ₄	L ₅	L ₈	L ₉	L ₁₀	L ₁₆	
28	1FK7022-5	LP050-M01	50 (1.97)	35 (1.38)	12 (0.47)	44 (1.73)	M4	18 (0.71)	4 (0.16)	7 (0.28)	8 (0.31)	14 (0.55)	4 (0.16)	50 (1.97)	88 (3.46)	
	1FK7022-5	LP070-M01	70 (2.76)	52 (2.05)	16 (0.63)	62 (2.44)	M5	28 (1.10)	5 (0.20)	8 (0.31)	10 (0.39)	18 (0.71)	5 (0.20)	70 (2.76)	119 (4.69)	
36	1FK7032-5	LP070-M01	70 (2.76)	52 (2.05)	16 (0.63)	62 (2.44)	M5	28 (1.10)	5 (0.20)	8 (0.31)	10 (0.39)	18 (0.71)	5 (0.20)	70 (2.76)	126 (4.96)	
	1FK7034-5															
48	1FK7040-5	LP090-M01	90 (3.54)	68 (2.68)	22 (0.87)	80 (3.15)	M6	36 (1.42)	5 (0.20)	10 (0.39)	12 (0.47)	25 (0.98)	6 (0.24)	90 (3.54)	158 (6.22)	
	1FK7042-5															
63	1FK7060-5	LP120-M01	120 (4.72)	90 (3.54)	32 (1.26)	108 (4.25)	M8	58 (2.28)	6 (0.24)	12 (0.47)	16 (0.63)	35 (1.38)	10 (0.39)	120 (4.72)	210 (8.27)	
	1FK7063-5															
80	1FK7080-5	LP155-M01	155 (6.10)	120 (4.72)	40 (1.57)	140 (5.51)	M10	82 (3.23)	8 (0.31)	15 (0.59)	20 (0.79)	43 (1.69)	12 (0.47)	150 (5.91)	266 (10.47)	
	1FK7083-5															

1FK702 -5
1FK703 -5
1FK704 -5
1FK706 -5
1FK708 -5

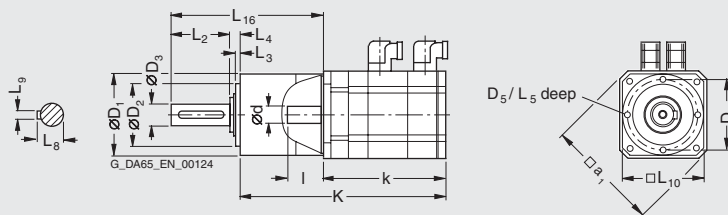

¹⁾ 1FK7022 and 1FK703. motors cannot be supplied with a basic absolute encoder.

AC motors

Dimension drawings - synchronous motors

1FK7 Compact motors without/with DRIVE-CLiQ with LP+ planetary gearbox, single-stage

For motor		Dimensions in mm (in)															
Shaft height	Type	DIN IEC	Resolver				Basic absolute encoder (EnDat) Incremental encoder sin/cos 1 V _{pp}				Absolute encoder (EnDat)				l	d	a ₁
			without brake		with brake		without brake		with brake		without brake		with brake				
			k	K	k	K	k	K	k	K	k	K	k	K			
1FK7 Compact with LP+ planetary gearbox, single-stage, type IM B5, natural cooling, with connector, with/without brake																	
100	1FK7100-5		185 (7.28)	374 (14.72)	204 (8.03)	393 (15.47)	208 (8.19)	396 (15.59)	227 (8.94)	415 (16.34)	216 (8.50)	404 (15.91)	235 (9.25)	423 (16.65)	80 (3.15)	38 (1.50)	240 (9.45)
	1FK7101-5		211 (8.31)	400 (15.75)	240 (9.45)	429 (16.89)	234 (9.21)	422 (16.61)	263 (10.35)	452 (17.80)	242 (9.53)	430 (16.93)	271 (10.67)	460 (18.11)			
	1FK7103-5		237 (9.33)	426 (16.77)	266 (10.47)	455 (17.91)	260 (10.24)	448 (17.64)	289 (11.38)	478 (18.82)	268 (10.55)	456 (17.95)	297 (11.69)	486 (19.13)			
	1FK7105-5		289 (11.38)	478 (18.82)	318 (12.52)	507 (19.96)	312 (12.28)	500 (19.69)	341 (13.43)	530 (20.87)	320 (12.60)	508 (20.00)	349 (13.74)	538 (21.18)			

Shaft height	Type	Planetary gearbox Type	Dimensions in mm (in)													
			D ₁	D ₂	D ₃	D ₄	D ₅	L ₂	L ₃	L ₄	L ₅	L ₈	L ₉	L ₁₀	L ₁₆	
100	1FK710-5	LP155-M01	155 (6.10)	120 (4.72)	40 (1.57)	140 (5.51)	M10	82 (3.23)	8 (0.31)	15 (0.59)	20 (0.79)	43 (1.69)	12 (0.47)	150 (5.91)	286 (11.26)	

1FK710 -5

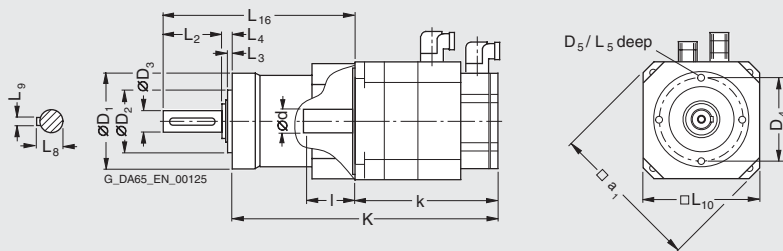

AC motors

Dimension drawings - synchronous motors

1FK7 High Dynamic motors without/with DRIVE-CLiQ with LP+ planetary gearbox, single-stage

For motor		Dimensions in mm (in)															
Shaft height	Type	DIN IEC	Resolver				Basic absolute encoder (EnDat) ¹⁾ sin/cos 1 V _{pp}				Absolute encoder (EnDat)						
			without brake		with brake		without brake		with brake		without brake		with brake				
			k LB	K	k LB	K	k LB	K	k LB	K	k LB	K	k LB	K			
			l	d	a ₁	P											
1FK7 High Dynamic with LP+ planetary gearbox, single-stage, type IM B5, natural cooling, with connector, with/without brake																	
36	1FK7033-7		170 (6.69)	260 (10.24)	195 (7.68)	285 (11.22)	195 (7.68)	285 (11.22)	220 (8.66)	310 (12.20)	195 (7.68)	285 (11.22)	220 (8.66)	310 (12.20)	30 (1.18)	14 (0.55)	92 (3.62)
48	1FK7043-7		191 (7.52)	303 (11.93)	220 (8.66)	332 (13.07)	212 (8.35)	324 (12.76)	240 (9.45)	352 (13.86)	220 (8.66)	332 (13.07)	249 (9.80)	361 (14.21)	40 (1.57)	19 (0.75)	120 (4.72)
	1FK7044-7		216 (8.50)	328 (12.91)	245 (9.65)	357 (14.06)	237 (9.33)	349 (13.74)	265 (10.43)	377 (14.84)	245 (9.65)	357 (14.06)	274 (10.79)	386 (15.20)			
63	1FK7061-7		185 (7.28)	325 (12.80)	228 (8.98)	368 (14.49)	208 (8.19)	348 (13.70)	251 (9.88)	391 (15.39)	217 (8.54)	357 (14.06)	260 (10.24)	400 (15.75)	50 (1.97)	24 (0.94)	155 (6.10)
	1FK7064-7		249 (9.80)	389 (15.31)	292 (11.50)	432 (17.01)	272 (10.71)	412 (16.22)	315 (12.40)	455 (17.91)	281 (11.06)	421 (16.57)	324 (12.76)	464 (18.27)			
80	1FK7085-7		261 (10.28)	430 (16.93)	304 (11.97)	473 (18.62)	284 (11.18)	453 (17.83)	326 (12.83)	495 (19.49)	292 (11.50)	461 (18.15)	335 (13.19)	504 (19.84)	58 (2.28)	32 (1.26)	186 (7.32)
	1FK7086-7																

Shaft height	Type	Planetary gearbox Type	D ₁	D ₂	D ₃	D ₄	D ₅	L ₂	L ₃	L ₄	L ₅	L ₈	L ₉	L ₁₀	L ₁₆
			—	—	—	—	—	—	—	—	—	—	—	—	—
36	1FK7033-7	LP070-M01	70 (2.76)	52 (2.05)	16 (0.63)	62 (2.44)	M5	28 (1.10)	5 (0.20)	8 (0.31)	10 (0.39)	18 (0.71)	5 (0.20)	70 (2.76)	126 (4.96)
48	1FK7043-7	LP090-M01	90 (3.54)	68 (2.68)	22 (0.87)	80 (3.15)	M6	36 (1.42)	5 (0.20)	10 (0.39)	12 (0.47)	25 (0.98)	6 (0.24)	90 (3.54)	158 (6.22)
	1FK7044-7														
63	1FK7061-7	LP120-M01	120 (4.72)	90 (3.54)	32 (1.26)	108 (4.25)	M8	58 (2.28)	6 (0.24)	12 (0.47)	16 (0.63)	35 (1.38)	10 (0.39)	120 (4.72)	210 (8.27)
	1FK7064-7														
80	1FK7085-7	LP155-M01	155 (6.10)	120 (4.72)	40 (1.57)	140 (5.51)	M10	82 (3.23)	8 (0.31)	15 (0.59)	20 (0.79)	43 (1.69)	12 (0.47)	150 (5.91)	266 (10.47)
	1FK7086-7														

1FK7033-7
1FK704 .-7
1FK706 .-7
1FK708 .-7

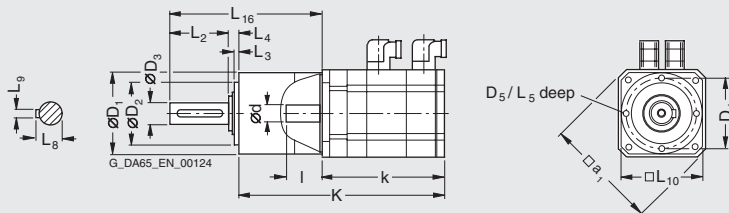

¹⁾ 1FK7033 motor cannot be supplied with a basic absolute encoder.



AC motors

Dimension drawings - synchronous motors

1FK7-DYA motors without/with DRIVE-CLiQ (with planetary gearbox, single-stage)

For motor		Dimensions in mm (in)				Basic absolute encoder (EnDat) ¹⁾ Incremental encoder sin/cos 1 V _{PP}				Absolute encoder (EnDat)			
Shaft height	Type	Resolver without brake		with brake		without brake		with brake		without brake		with brake	
		K	K1	K	K1	K	K1	K	K1	K	K1	K	K1
1FK7-DYA (with planetary gearbox, single-stage), type IM B5, natural cooling, with connector, with/without brake													
36	1FK7032-5	197 (7.76)	177 (6.97)	222 (8.74)	202 (7.95)	222 (8.74)	202 (7.95)	247 (9.72)	227 (8.94)	222 (8.74)	202 (7.95)	247 (9.72)	227 (8.94)
	1FK7034-5	222 (8.74)	202 (7.95)	247 (9.72)	227 (8.94)	247 (9.72)	227 (8.94)	272 (10.71)	252 (9.92)	247 (9.72)	227 (8.94)	272 (10.71)	252 (9.92)
48	1FK7040-5	194 (7.64)	174 (6.85)	223 (8.78)	203 (7.99)	214 (8.43)	194 (7.64)	243 (9.57)	223 (8.78)	223 (8.78)	203 (7.99)	252 (9.92)	232 (9.13)
	1FK7042-5	221 (8.70)	201 (7.91)	250 (9.84)	230 (9.06)	242 (9.53)	222 (8.74)	271 (10.67)	251 (9.88)	250 (9.84)	230 (9.06)	279 (10.98)	259 (10.20)
63	1FK7060-5	233 (9.17)	208 (8.19)	261 (10.28)	236 (9.29)	256 (10.08)	231 (9.09)	284 (11.18)	259 (10.20)	264 (10.39)	239 (9.41)	292 (11.50)	267 (10.51)
	1FK7063-5	278 (10.94)	253 (9.96)	306 (12.05)	281 (11.06)	301 (11.85)	276 (10.87)	329 (12.95)	304 (11.97)	309 (12.17)	284 (11.18)	337 (13.27)	312 (12.28)
80	1FK7080-5	250 (9.84)	220 (8.66)	278 (10.94)	248 (9.76)	273 (10.75)	243 (9.57)	300 (11.81)	270 (10.63)	281 (11.06)	251 (9.88)	309 (12.17)	279 (10.98)
	1FK7083-5	288 (11.34)	258 (10.16)	339 (13.35)	309 (12.17)	311 (12.24)	281 (11.06)	362 (14.25)	332 (13.07)	319 (12.56)	289 (11.38)	370 (14.57)	340 (13.39)

		Planetary gearbox																																			
Shaft height	Type	Type	D1		D2		D3		D4		D5		D7		D8		L1		L2		L3		L4		L5		L8		L9		L10		L12				
			36	1FK7032-5	DYA70-10	70 (2.76)	52 (2.05)	16 (0.63)	62 (2.44)	M5	82 (3.23)	5.5 (0.22)	56 (2.20)	28 (1.10)	5 (0.20)	8 (0.31)	10 (0.39)	18 (0.71)	5 (0.20)	20 (0.79)	2.99	36	1FK7034-5	DYA70-5	70 (2.76)	52 (2.05)	16 (0.63)	62 (2.44)	M5	82 (3.23)	5.5 (0.22)	56 (2.20)	28 (1.10)	5 (0.20)	8 (0.31)	10 (0.39)	18 (0.71)
1FK7040-5	DYA90-10	90 (3.54)		68 (2.68)	22 (0.87)	80 (3.15)	M6	105 (4.13)	7 (0.28)	66 (2.60)	36 (1.42)	5 (0.20)	10 (0.39)	12 (0.47)	24.5 (0.96)	6 (0.24)	20 (0.79)	101 (3.98)																			
48	1FK7042-5	DYA90-5	90 (3.54)	68 (2.68)	22 (0.87)	80 (3.15)	M6	105 (4.13)	7 (0.28)	66 (2.60)	36 (1.42)	5 (0.20)	10 (0.39)	12 (0.47)	24.5 (0.96)	6 (0.24)	20 (0.79)	101 (3.98)																			
	1FK7060-5	DYA120-10	120 (4.72)	90 (3.54)	32 (1.26)	108 (4.25)	M8	140 (5.51)	9 (0.35)	95 (3.74)	58 (2.28)	6 (0.24)	12 (0.47)	16 (0.63)	35 (1.38)	10 (0.39)	25 (0.98)	128 (5.04)																			
63	1FK7063-5	DYA120-5	120 (4.72)	90 (3.54)	32 (1.26)	108 (4.25)	M8	140 (5.51)	9 (0.35)	95 (3.74)	58 (2.28)	6 (0.24)	12 (0.47)	16 (0.63)	35 (1.38)	10 (0.39)	25 (0.98)	128 (5.04)																			
	1FK7080-5	DYA155-10	155 (6.10)	120 (4.72)	40 (1.57)	140 (5.51)	M10	170 (6.69)	11 (0.43)	127 (5.00)	82 (3.23)	8 (0.31)	15 (0.59)	20 (0.79)	43 (1.69)	12 (0.47)	30 (1.18)	161 (6.34)																			
80	1FK7083-5	DYA155-5	155 (6.10)	120 (4.72)	40 (1.57)	140 (5.51)	M10	170 (6.69)	11 (0.43)	127 (5.00)	82 (3.23)	8 (0.31)	15 (0.59)	20 (0.79)	43 (1.69)	12 (0.47)	30 (1.18)	161 (6.34)																			

1FK703 .-5
1FK704 .-5
1FK706 .-5
1FK708 .-5

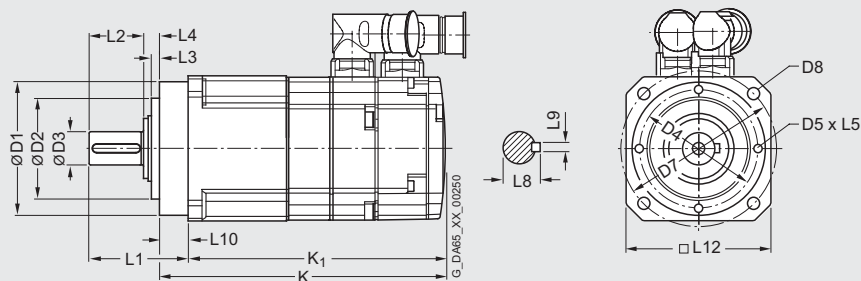

¹⁾ 1FK7032 and 1FK7034 motors cannot be supplied with a basic absolute encoder.

AC motors

Dimension drawings - synchronous motors

1FS6 motors
Natural cooling

For motor		Dimensions in mm (in)													DE shaft extension		
Shaft height	Type	DIN IEC	a ₁ P	b ₁ N	c ₁ LA	e ₁ M	f AB	f ₁ T	g AC	g ₂ -	h H	i ₂ LE	k LB	s ₂ S ₂	d D	d ₆ -	l E
1FS6, type IM B5 (shaft heights 71, 90) IM B35 (shaft heights 112, 132), natural cooling, with terminal box																	
71	1FS6074		146 (5.75)	110 (4.33)	12 (0.47)	130 (5.12)	-	3.5 (0.14)	128 (5.04)	147.5 (5.81)	64 (2.52)	50 (1.97)	414 (16.30)	9 (0.35)	24 (0.94)	M8	50 (1.97)
90	1FS6096		194 (7.64)	130 (5.12)	12 (0.47)	165 (6.50)	-	3.5 (0.14)	166 (6.54)	168 (6.61)	83 (3.27)	58 (2.28)	476 (18.74)	11 (0.43)	32 (1.26)	M12	58 (2.28)
112	1FS6115		240 (9.45)	180 (7.09)	14 (0.55)	215 (8.46)	235 (9.25)	4 (0.16)	200 (7.87)	184 (7.24)	112 (4.41)	80 (3.15)	515 (20.28)	14 (0.55)	38 (1.5)	M12	80 (3.15)
132	1FS6134		-	250 (9.84)	18 (0.71)	300 (11.81)	260 (10.24)	5 (0.20)	256 (10.08)	209 (8.23)	132 (5.20)	82 (3.23)	559 (22.01)	18 (0.71)	48 (1.89)	M16	82 (3.23)

1FS6074
1FS6096

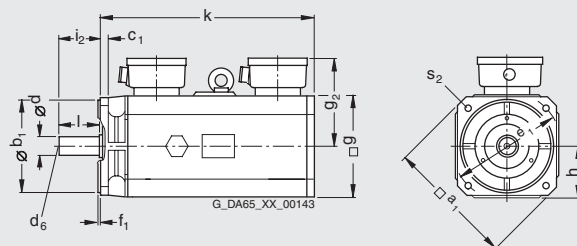

1FS6115

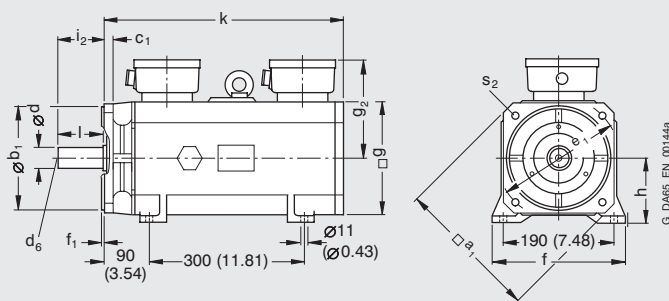

1FS6134

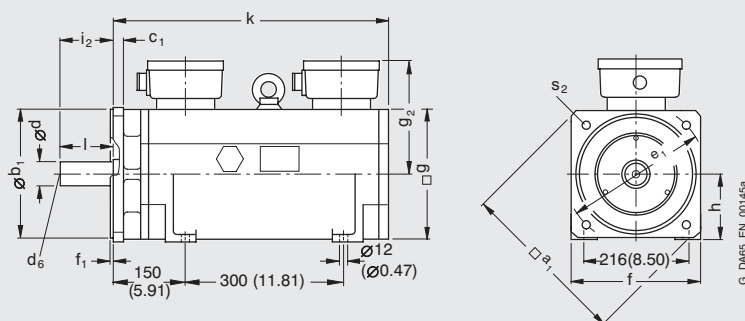

3

AC motors

Dimension drawings - synchronous motors

1FW3 motors without/with DRIVE-CLiQ Water cooling

For motor		Dimensions in mm (in)															
Shaft height	Type	DIN IEC	b	e	k	Terminal box gk 230			Terminal box gk 420			Terminal box gk 630					
						o	p	r	o	p	r	o	p	r	x ₁		
			-	-	L	-	HD	LL	x ₁	AG	-	HD	LL	x ₁	AG		

1FW3, type IM B5, water cooling, with terminal box, belt-mounted encoder

160	1FW3150		68 (2.68)	256 (10.08)	260.5 (10.26)	159.5 (6.28)	393 (15.47)	122 (4.80)	117 (4.61)	177 (6.97)	409 (16.10)	162 (6.38)	162 (6.38)	201 (7.91)	427 (16.81)	210 (8.27)	210 (8.27)
	1FW3152		125 (4.92)	313 (12.32)	317.5 (12.50)												
	1FW3154		174 (6.85)	362 (14.25)	366.5 (14.43)												
	1FW3155		226 (8.90)	414 (16.30)	418.5 (16.48)												
	1FW3156		279 (10.98)	467 (18.39)	471.5 (18.56)												

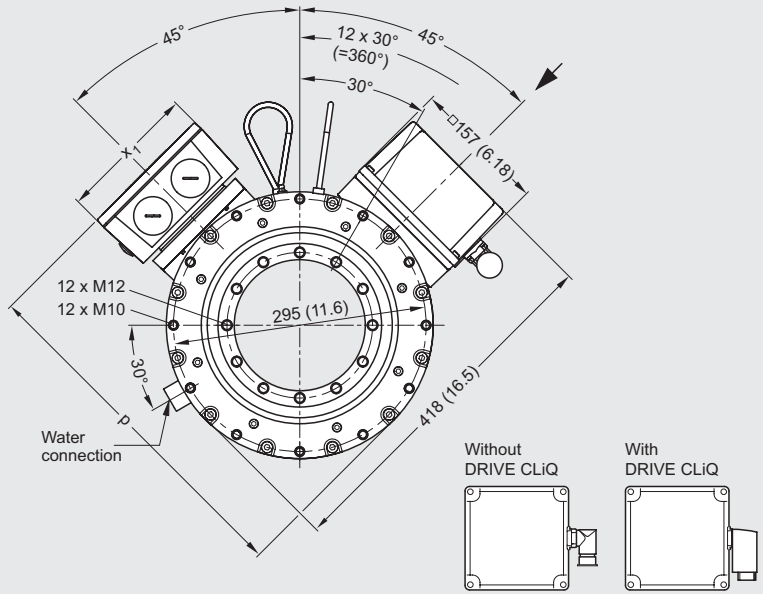
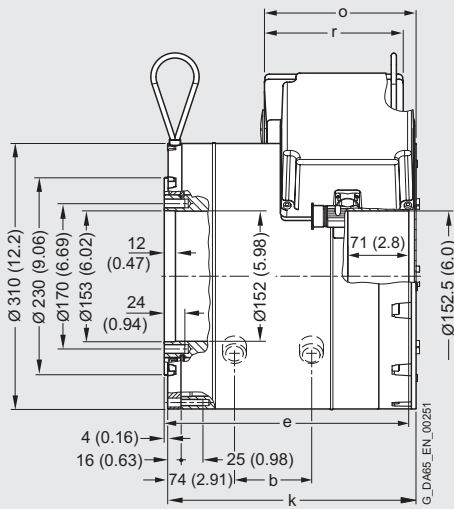

3

AC motors

Dimension drawings - synchronous motors

1FW3 motors without/with DRIVE-CLiQ
Water cooling

For motor Dimensions in mm (in)

Shaft height	Type	DIN IEC	Terminal box gk 230						Terminal box gk 420			Terminal box gk 630					
			b	e	k	o	p	r	x ₁	o	p	r	x ₁	o	p	r	x ₁
1FW3, type IM B5, water cooling, with terminal box, coaxially mounted encoder																	
160	1FW3150		68 (2.68)	199 (7.83)	277.5 (10.93)	174 (6.85)	393 (15.47)	122 (4.80)	117 (4.61)	194 (7.64)	410 (16.14)	162 (6.38)	162 (6.38)	218 (8.58)	427 (16.81)	210 (8.27)	210 (8.27)
	1FW3152		125 (4.92)	256 (10.08)	334.5 (13.17)												
	1FW3154		174 (6.85)	305 (12.01)	383.5 (15.10)												
	1FW3155		226 (8.90)	357 (14.06)	435.5 (17.15)												
	1FW3156		279 (10.98)	410 (16.14)	488.5 (19.23)												

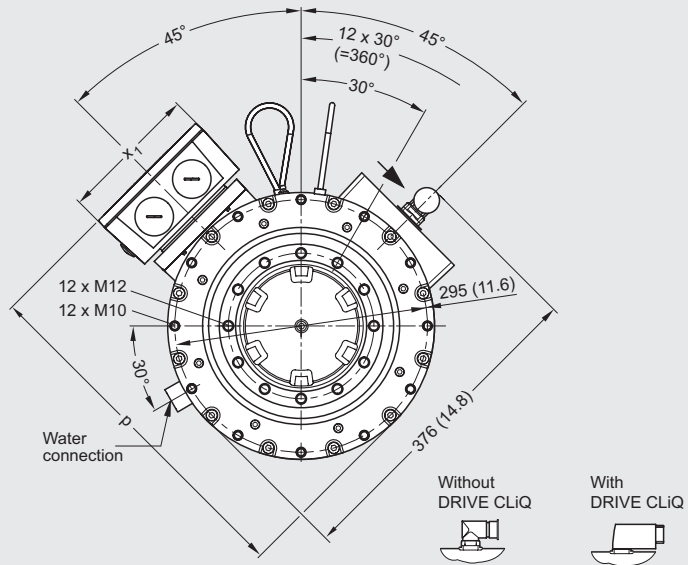
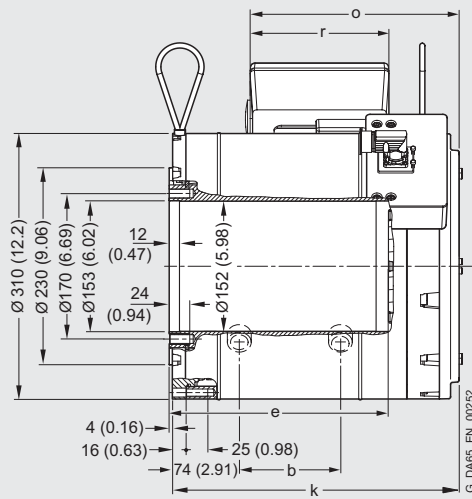

3

AC motors

Dimension drawings - synchronous motors

1FW3 motors without/with DRIVE-CLiQ Water cooling

For motor Dimensions in mm (in)

Shaft height	Type	DIN IEC	Terminal box gk 230							Terminal box gk 420				Terminal box gk 630				
			b	c	e	k	o	p	r	x ₁	o	p	r	x ₁	o	p	r	x ₁
			-	C	-	L	-	HD	LL	AG	-	HD	LL	AG	-	HD	LL	AG
1FW3, type IM B5, water cooling, with terminal box, belt-mounted encoder																		
200	1FW3201		48.5 (1.91)	67.5 (2.66)	229 (9.02)	235.5 (9.27)	158 (6.22)	474 (18.66)	122 (4.80)	117 (4.61)	175 (6.89)	490 (19.29)	162 (6.38)	162 (6.38)	226 (8.90)	508 (20.00)	210 (8.27)	210 (8.27)
	1FW3202		94.5 (3.72)	67.5 (2.66)	275 (10.83)	281.5 (11.08)												
	1FW3203		137 (5.39)	69.5 (2.74)	321.5 (12.66)	328 (12.91)												
	1FW3204		206 (8.11)	69.5 (2.74)	390.5 (15.37)	397 (15.63)												
	1FW3206		298.5 (11.75)	69.5 (2.74)	483 (19.02)	489.5 (19.27)												
	1FW3208		413.5 (16.28)	69.5 (2.74)	598 (23.54)	604.5 (23.80)												

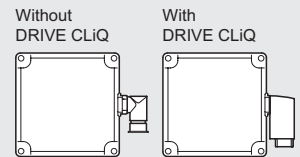
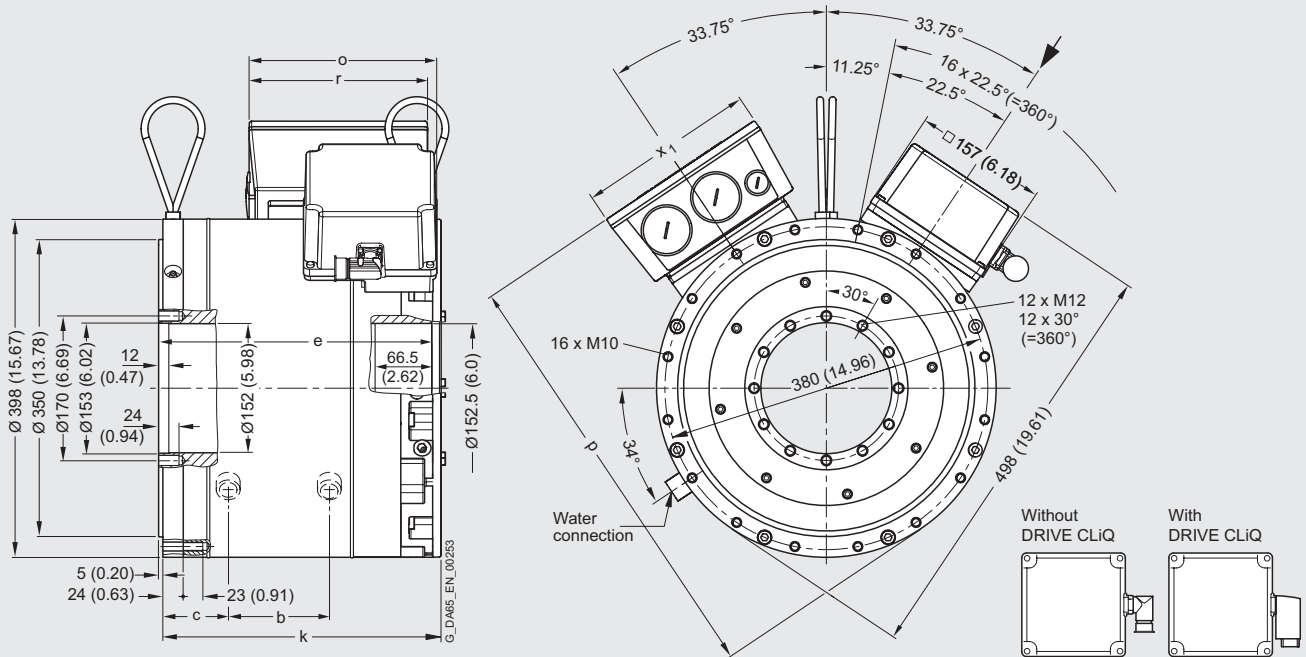

AC motors

Dimension drawings - synchronous motors

1FW3 motors without/with DRIVE-CLiQ Water cooling

For motor		Dimensions in mm (in)																	
Shaft height	Type	DIN IEC					Terminal box gk 230				Terminal box gk 420				Terminal box gk 630				
			b	c	e	k	o	p	r	x ₁	o	p	r	x ₁	o	p	r	x ₁	
			-	C	-	L	-	HD	LL	AG	-	HD	LL	AG	-	HD	LL	AG	
1FW3, type IM B5, water cooling, with terminal box, coaxially mounted encoder																			
200	1FW3201		48.5 (1.91)	67.5 (2.66)	172 (6.77)	247.5 (9.74)	167 (6.57)	474 (18.66)	122 (4.80)	117 (4.61)	188 (7.40)	490 (19.29)	162 (6.38)	162 (6.38)	239 (9.41)	508 (20.00)	210 (8.27)	210 (8.27)	
	1FW3202		94.5 (3.72)	67.5 (2.66)	218 (8.58)	293.5 (11.56)													
	1FW3203		137 (5.39)	69.5 (2.74)	264.5 (10.41)	340 (13.39)													
	1FW3204		206 (8.11)	69.5 (2.74)	333.5 (13.13)	409 (16.10)													
	1FW3206		298.5 (11.75)	69.5 (2.74)	426 (16.77)	501.5 (19.74)													
	1FW3208		413.5 (16.28)	69.5 (2.74)	541 (21.30)	616.5 (24.27)													

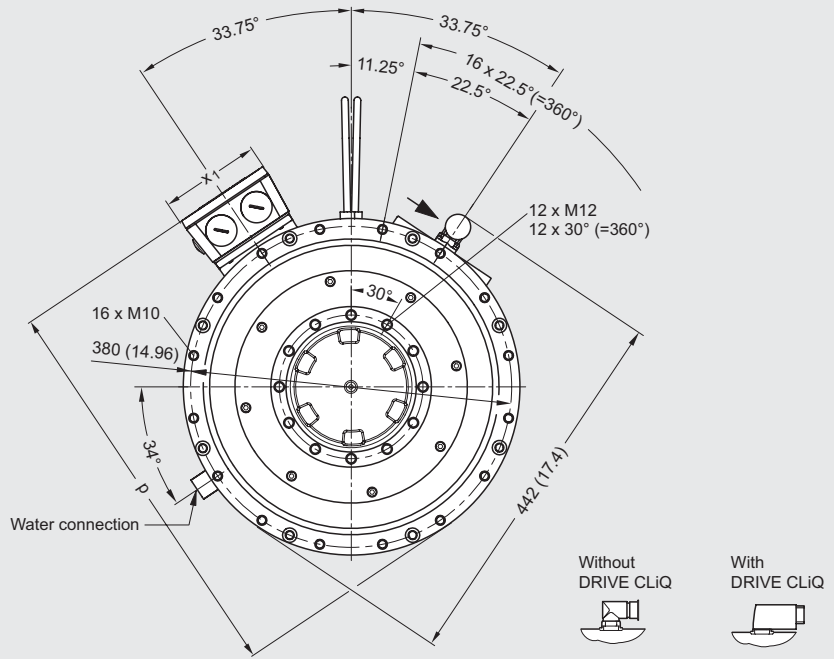
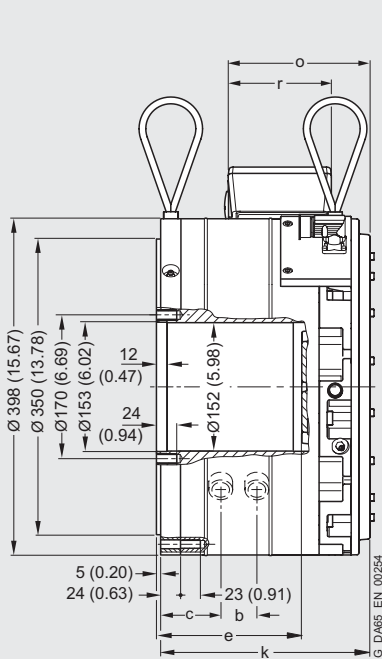

AC motors

Dimension drawings - synchronous motors

1FW3 motors without/with DRIVE-CLiQ Water cooling

For motor Dimensions in mm (in)

Shaft height	Type	DIN IEC	a B	b -	c C	e -	k L
--------------	------	---------	-----	-----	-----	-----	-----

1FW3, type IM B35, water cooling, with terminal box, belt-mounted encoder

280	1FW3281	258 (10.16)	217 (8.54)	174 (6.85)	571 (22.48)	574 (22.60)
	1FW3283	342.5 (13.48)	301.5 (11.87)		655.5 (25.81)	658.5 (25.93)
	1FW3285	468.5 (18.44)	427.5 (16.83)		781.5 (30.77)	784.5 (30.89)
	1FW3288	637 (25.08)	596 (23.46)		950 (37.40)	953 (37.52)

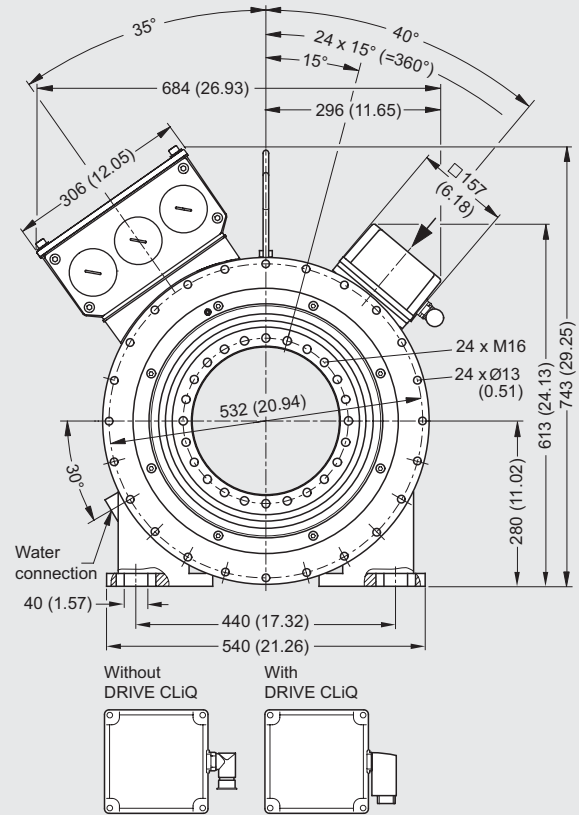
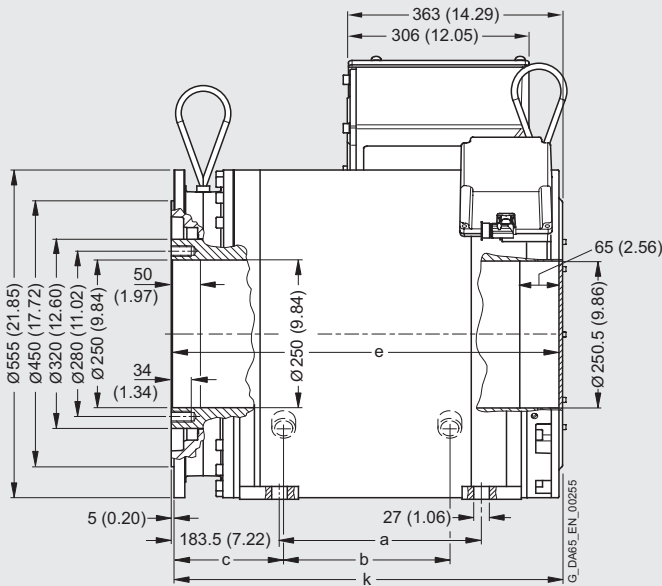

AC motors

Dimension drawings - synchronous motors

1FW3 motors without/with DRIVE-CLiQ Water cooling

For motor Dimensions in mm (in)

Shaft height	Type	DIN IEC	a B	b -	c C	e -	k L
1FW3, type IM B35, water cooling, with terminal box, coaxially mounted encoder							
280	1FW3281		258 (10.16)	217 (8.54)	174 (6.85)	514 (20.24)	589.5 (23.56)
	1FW3283		342.5 (13.48)	301.5 (11.87)		598.5 (23.56)	674 (26.54)
	1FW3285		468.5 (18.44)	427.5 (16.83)		724.5 (28.52)	800 (31.50)
	1FW3288		637 (25.08)	596 (23.46)		893 (35.16)	968.5 (38.13)

3

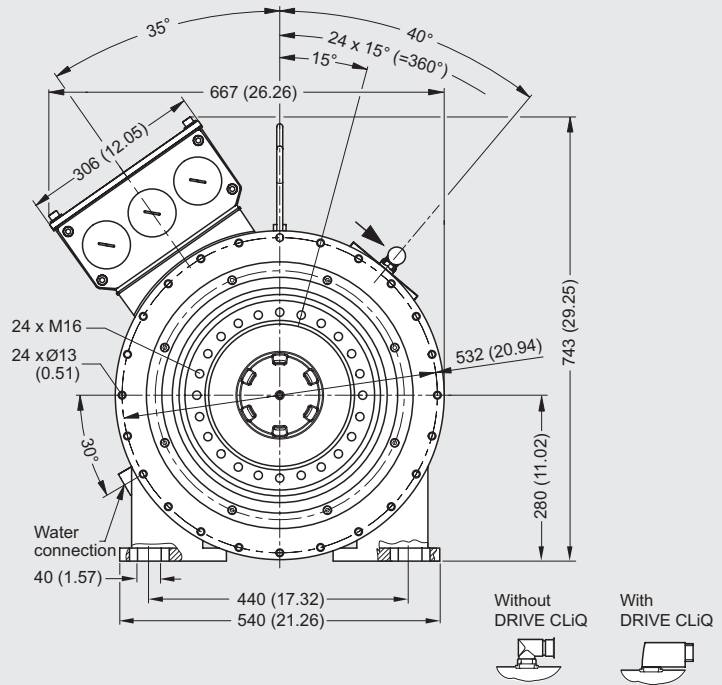
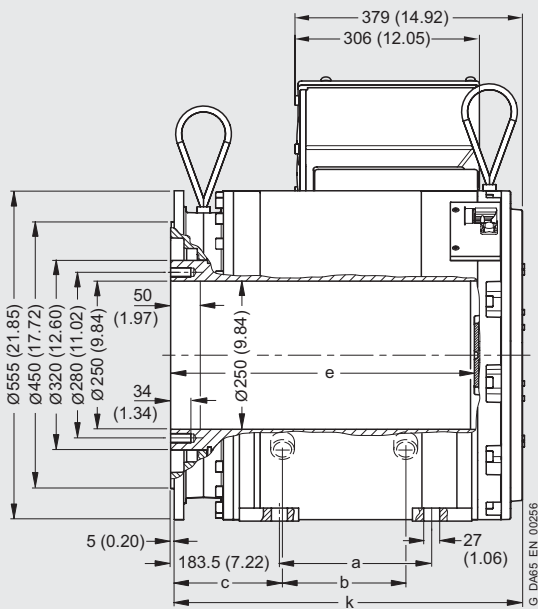

AC motors

Dimension drawings - asynchronous motors

1PH7 motors Forced ventilation

For motor		Dimensions in mm (in)																	
Shaft height	Type	DIN IEC	a B	b A	c LA	e M	f AB	h H	k LB	k ₁ -	m BA	m ₁ -	m ₂ -	n AA	p HD	s K	s ₃ -	w ₁ C	
1PH7, type IM B3, forced ventilation																			
100	1PH7101		202.5 (7.97)	160 (6.30)	11 (0.43)	263 (10.35)	196 (7.72)	100 (3.94)	411 (16.18)	434 (17.09)	52 (2.05)	64 (2.52)	27 (1.06)	39 (1.54)	220 (8.66)	12 (0.47)	Pg 29	40 (1.57)	
	1PH7103 1PH7105		297.5 (11.71)			358 (14.09)			506 (19.92)	529 (20.83)									
	1PH7107																		
132	1PH7131		265.5 (10.45)	216 (8.50)	14 (0.55)	341 (13.43)	260 (10.24)	132 (5.20)	538 (21.18)	561 (22.09)	63 (2.48)	75 (2.95)	33 (1.30)	52 (2.05)	275 (10.83)	12 (0.47)	Pg 36	50 (1.97)	
	1PH7133 1PH7135		350.5 (13.80)			426 (16.77)			623 (24.53)	646 (25.43)									
	1PH7137																		
160	1PH7163		346.5 (13.64)	254 (10.00)	17 (0.67)	438 (17.24)	314 (12.36)	160 (6.30)	640 (25.20)	663 (26.10)	78 (3.07)	81 (3.19)	42 (1.65)	62 (2.44)	330 (12.99)	14 (0.55)	Pg 42	64 (2.52)	
	1PH7167		406.5 (16.00)			498 (19.61)			700 (27.56)	723 (28.46)									

DE shaft extension

Shaft height	Type	DIN IEC	d D	d ₆ -	l E	t GA	u F
100	1PH7101		38 (1.50)	M12	80 (3.15)	41 (1.61)	10 (0.39)
	1PH7103 1PH7105 1PH7107						
132	1PH7131		42 (1.65)	M16	110 (4.33)	45 (1.77)	12 (0.47)
	1PH7133 1PH7135 1PH7137						
160	1PH7163		55 (2.17)	M20	110 (4.33)	59 (2.32)	16 (0.63)
	1PH7167						

For deviating and additional dimensions for 1PH7 motors with DRIVE-CLiQ, see "1PH7 motors with DRIVE-CLiQ".

1PH710 .
1PH713 .
1PH716 .

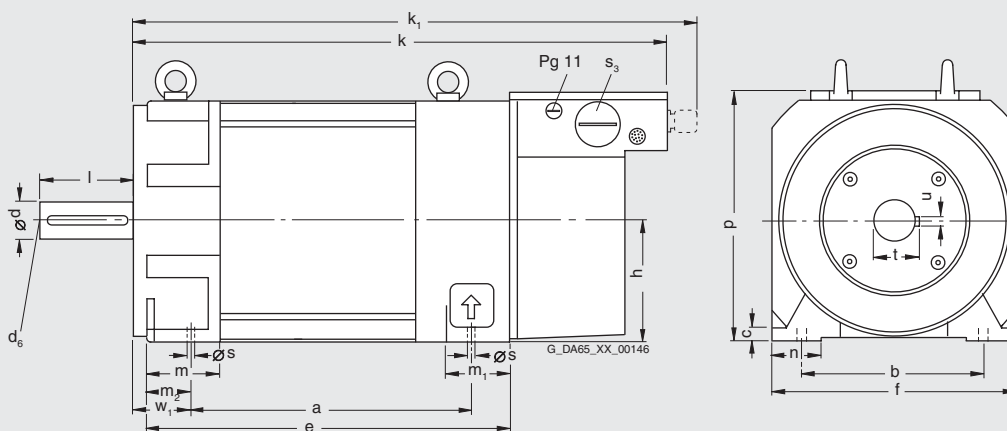

AC motors

Dimension drawings - asynchronous motors

1PH7 motors
Forced ventilation

For motor		Dimensions in mm (in)														
Shaft height	Type	DIN IEC	a B	b A	c LA	e M	f AB	g AC	h H	k LB	k ₁ -	m BA	m ₁ -	m ₂ -	n AA	o -
1PH7, type IM B3, forced ventilation, air-flow direction DE to NDE																
180	1PH7184		430 (16.93)	279 (10.98)	14 (0.55)	510 (20.08)	360 (14.17)	408 (16.09)	180 (7.09)	835 (32.87)	-	60 (2.36)	120 (4.72)	35 (1.38)	65 (2.56)	541 (21.30)
	1PH7186		520 (20.47)			600 (23.62)				925 (36.42)						631 (24.84)
225	1PH7224		445 (17.52)	356 (14.02)	18 (0.71)	530 (20.87)	450 (17.72)	498 (19.61)	225 (8.86)	-	1100 (43.31)	60 (2.36)	120 (4.72)	40 (1.57)	85 (3.35)	629 (24.76)
	1PH7226		545 (21.46)			630 (24.80)					1200 (47.24)					729 (28.70)
	1PH7228		635 (25.00)			720 (28.35)					1290 (50.79)					819 (32.24)

Shaft height	Type	DIN IEC	Terminal box type 1XB7...			DE shaft extension						
			...322 p ¹⁾ HD	...422 p ¹⁾ HD	...700 p ¹⁾ HD	s K	w ₁ C	d D	d ₆ -	l E	t GA	u F
180	1PH7184		495 (19.49)	-	-	14.5 (0.57)	121 (4.76)	60 (2.36)	M20	140 (5.51)	64 (2.52)	18 (0.72)
	1PH7186			545 (21.46)	-			65 (2.56)			69 (2.72)	
225	1PH7224		595 (23.43)	645 (25.39)	680 (26.77)	18.5 (0.73)	149 (5.87)	75 (2.95)	M20	140 (5.51)	79.5 (3.13)	20 (0.79)
	1PH7226 1PH7228											

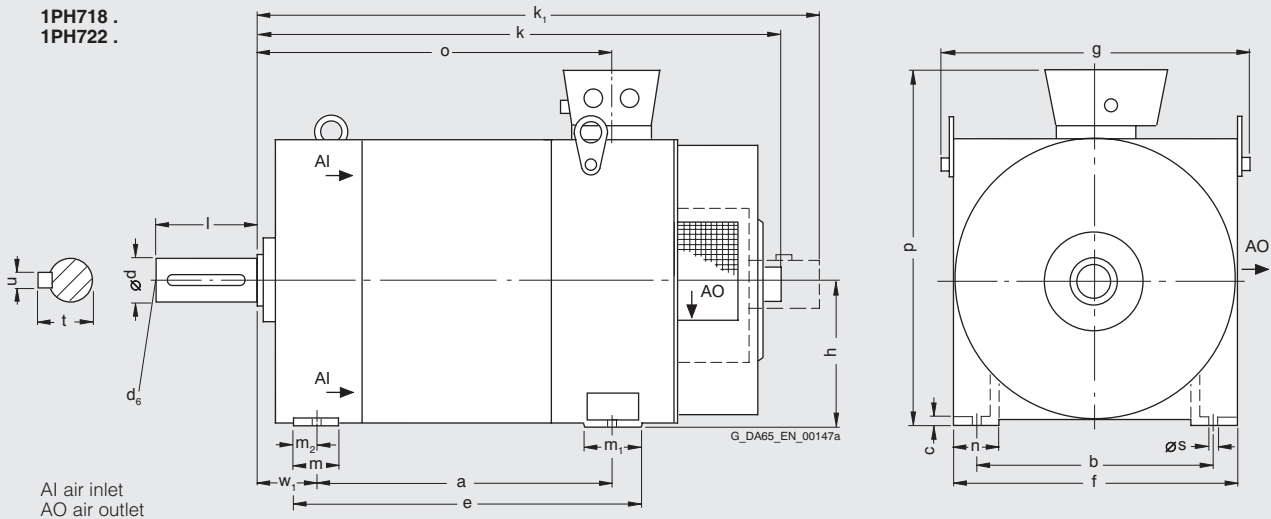

¹⁾ Maximum dimensions, depending on electrical version (terminal box type).

AC motors

Dimension drawings - asynchronous motors

1PH7 motors Forced ventilation

For motor		Dimensions in mm (in)															Terminal box type 1XB7...		
Shaft height	Type	DIN IEC	a	b	c	e	f	g	h	k	m	m ₁	m ₂	n	o	...322	...422	...700	
			B	A	LA	M	AB	AC	H	LB	BA	-	-	AA	-	p ¹ HD	p ¹ HD	p ¹ HD	
1PH7, type IM B3, forced ventilation, air-flow direction NDE to DE																			
180	1PH7184		430 (16.93)	279 (10.98)	14 (0.55)	510 (20.08)	360 (14.17)	405 (15.94)	180 (7.09)	1010 (39.76)	60 (2.36)	120 (4.72)	35 (1.38)	65 (2.56)	541 (21.30)	495 (19.49)	-	-	
	1PH7186		520 (20.47)			600 (23.62)				1100 (43.31)							560 (22.05)	-	
225	1PH7224		445 (17.52)	356 (14.02)	18 (0.71)	530 (20.87)	450 (17.72)	498 (19.61)	225 (8.86)	1090 (42.91)	60 (2.36)	120 (4.72)	40 (1.57)	85 (3.35)	629 (24.76)	595 (23.43)	645 (25.39)	680 (26.77)	
	1PH7226		545 (21.46)			630 (24.80)				1190 (46.85)							729 (28.70)		
	1PH7228		635 (25.00)			720 (28.35)				1280 (50.39)							819 (32.24)	-	

For motor		DE shaft extension							
Shaft height	Type	DIN IEC	s	w ₁	d	d ₆	l	t	u
			K	C	D	-	E	GA	F
180	1PH7184		14.5 (0.57)	121 (4.76)	60 (2.36)	M20	140 (5.51)	64 (2.52)	18 (0.71)
	1PH7186				65 (2.56)			69 (2.72)	
225	1PH7224		18.5 (0.73)	149 (5.87)	75 (2.95)	M20	140 (5.51)	79.5 (3.13)	20 (0.79)
	1PH7226								
	1PH7228								

1PH718 .

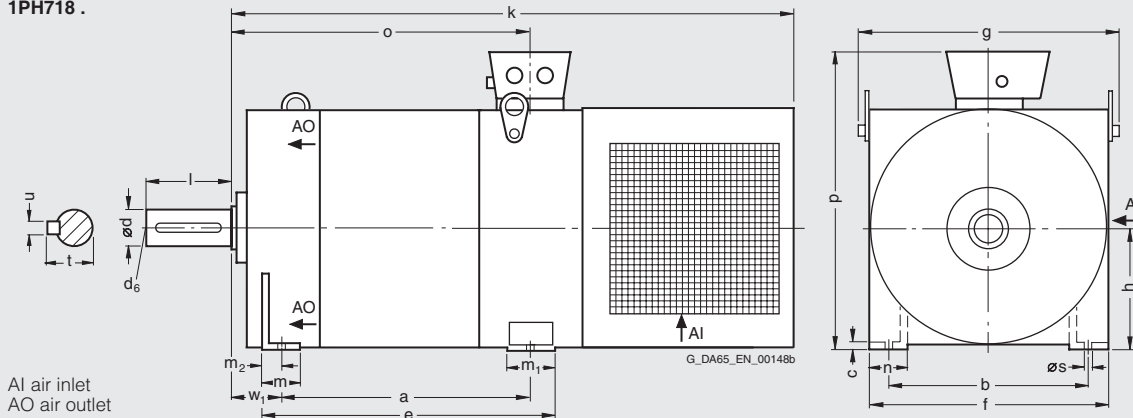

1PH722 .

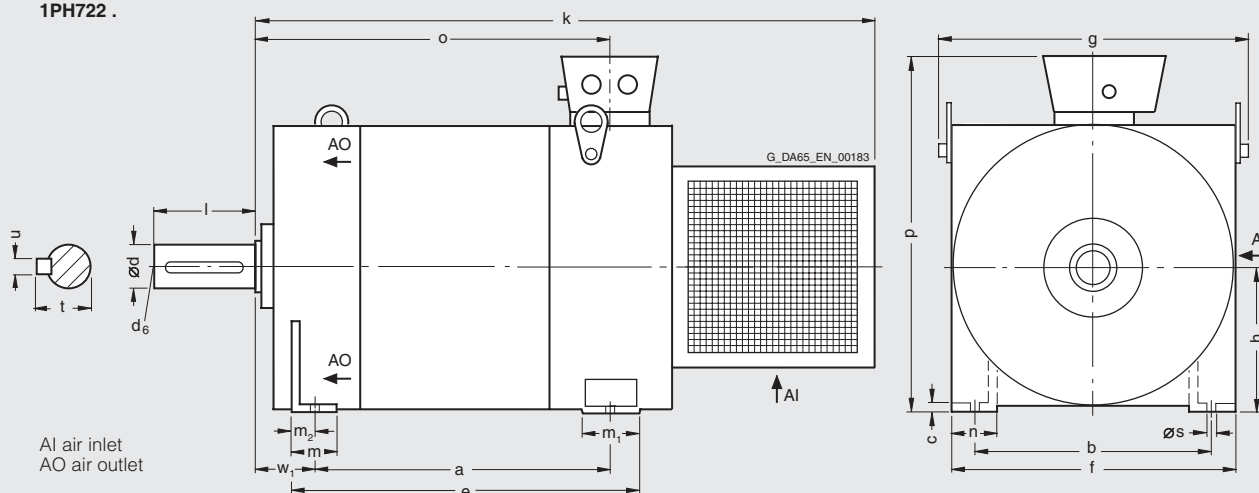

¹⁾ Maximum dimensions, depending on electrical version (terminal box type).

AC motors

Dimension drawings - asynchronous motors

1PH7 motors
Forced ventilation

For motor		Dimensions in mm (in)															
Shaft height	Type	DIN IEC	a B	b A	c HA	e BB	f AB	g ₂ AD	g ₄ -	h H	k LB	k ₁ -	k ₂ -	m ₁ -	m ₂ -	n AA	o -
Type IM B3, with external fan unit, air-flow direction NDE to DE																	
280	1PH7284		684 (26.93)	457 (17.99)	22 (0.87)	840 (33.07)	560 (22.05)	518 (20.39)	449 (17.68)	280 (11.02)	1146 (45.12)	489 (19.25)	546 (21.50)	108 (4.25)	78 (3.07)	100 (3.94)	731 (28.78)
	1PH7286		794 (31.26)			950 (37.40)					1256 (49.45)	599 (23.58)					841 (33.11)
	1PH7288		924 (36.38)			1080 (42.52)					1386 (54.57)	729 (28.70)					971 (38.23)

DE shaft extension

Shaft height	Type	DIN IEC	p ₂ -	s K	w ₁ C	d D	l E	t GA	u FA
280	1PH7284		1042 (41.02)	24 (0.94)	190 (7.48)	95 (3.74)	170 (6.69)	100 (3.94)	25 (0.98)
	1PH7286								
	1PH7288								

1PH728 .

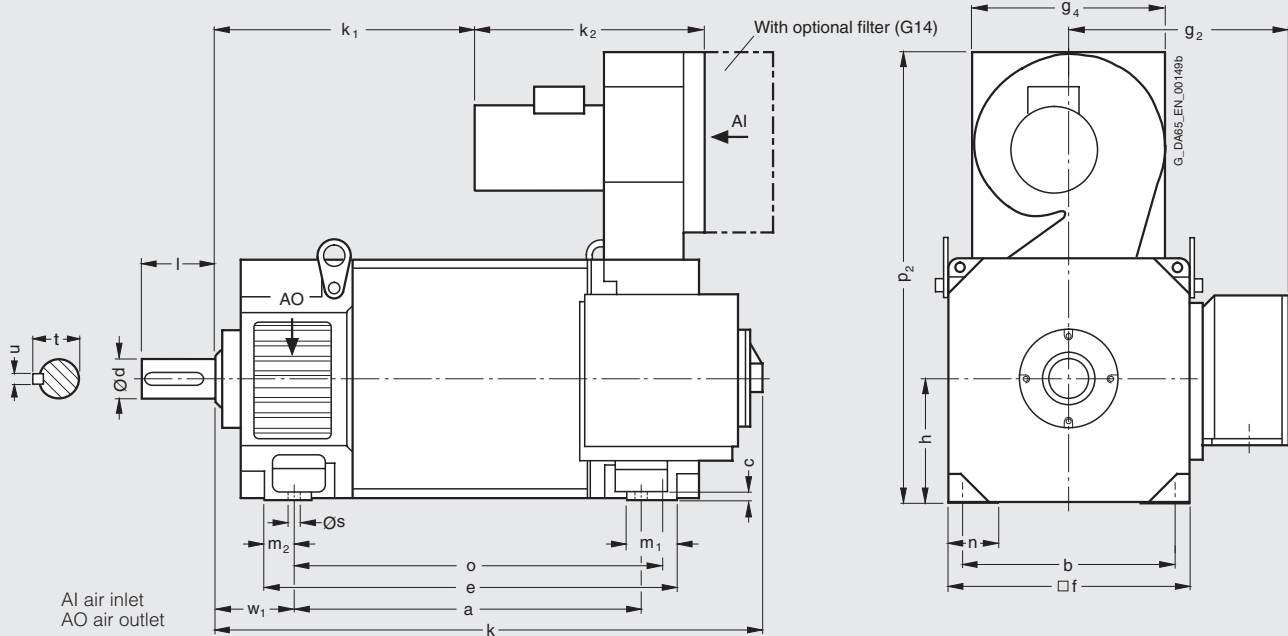

AC motors

Dimension drawings - asynchronous motors

1PH7 motors Forced ventilation

For motor		Dimensions in mm (in)															
Shaft height	Type	DIN IEC	a B	b A	c LA	e M	f AB	h H	k LB	k ₁ -	m BA	m ₁ -	m ₂ -	n AA	o -	p HD	
Type IM B3, with external fan unit, with pipe connection at NDE																	
100	1PH7101		202.5 (7.97)	160 (6.30)	11 (0.43)	263 (10.35)	196 (7.72)	100 (3.94)	441 (17.36)	411 (16.18)	52 (2.05)	64 (2.52)	25 (0.98)	39 (1.54)	161 (6.34)	220 (8.66)	
	1PH7103 1PH7105		297.5 (11.71)			358 (14.09)			536 (21.10)		506 (19.92)						
	1PH7107																
132	1PH7131		265.5 (10.45)	216 (8.50)	14 (0.55)	341 (13.43)	260 (10.24)	132 (5.20)	573 (22.56)	538 (21.18)	63 (2.48)	75 (2.95)	30 (1.18)	52 (2.05)	211.5 (8.33)	275 (10.83)	
	1PH7133 1PH7135		350.5 (13.80)			426 (16.77)			658 (25.91)		623 (24.53)						
	1PH7137																
160	1PH7163		346.5 (13.64)	254 (10.00)	17 (0.67)	438 (17.24)	314 (12.36)	160 (6.30)	674 (26.54)	640 (25.20)	78 (3.07)	81 (3.19)	36 (1.42)	62 (2.44)	253 (9.96)	330 (12.99)	
	1PH7167		406.5 (16.00)			498 (19.61)			734 (28.90)		700 (27.56)						

DE shaft extension

Shaft height	Type	DIN IEC	s K	s ₃ -	v -	w ₁ C	d D	d ₆ -	l E	t GA	u F
100	1PH710 .		12 (0.47)	Pg 29	10.5 (0.41)	40 (1.57)	38 (1.50)	M12	80 (3.15)	41.3 (1.63)	10 (0.39)
132	1PH713 .		12 (0.47)	Pg 36	17 (0.67)	50 (1.97)	42 (1.65)	M16	110 (4.33)	45.3 (1.78)	12 (0.47)
160	1PH716 .		14 (0.55)	Pg 42	17 (0.67)	64 (2.52)	55 (2.17)	M20	110 (4.33)	56.3 (2.22)	16 (0.63)

For deviating and additional dimensions for 1PH7 motors with DRIVE-CLiQ, see "1PH7 motors with DRIVE-CLiQ".

1PH710 .
1PH713 .
1PH716 .

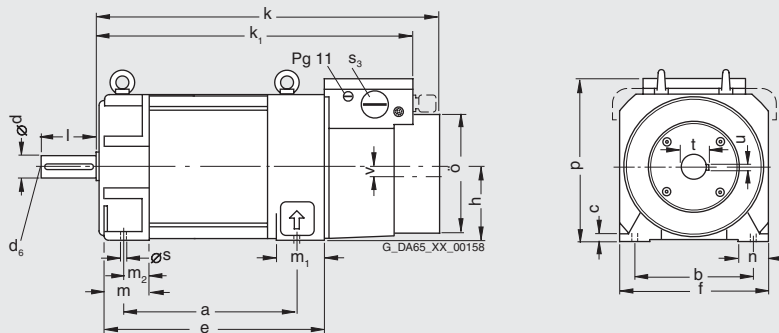

AC motors

Dimension drawings - asynchronous motors

1PH7 motors
Forced ventilation

For motor		Dimensions in mm (in)														
Shaft height	Type	DIN IEC	a B	b A	c LA	e M	f AB	g AC	h H	k LB	m BA	m ₁ -	m ₂ -	n AA	o -	
Type IM B3, with external fan unit, with pipe connection at NDE																
180	1PH7184		430 (16.93)	279 (10.98)	14 (0.55)	510 (20.08)	360 (14.17)	408 (16.06)	180 (7.09)	830 (32.68)	60 (2.36)	120 (4.72)	35 (1.38)	65 (2.56)	541 (21.30)	
	1PH7186		520 (20.47)			600 (23.62)				920 (36.22)					631 (24.84)	
225	1PH7224		445 (17.52)	356 (14.02)	18 (0.71)	530 (20.78)	450 (17.72)	498 (19.61)	225 (8.86)	950 (37.40)	60 (2.36)	120 (4.72)	40 (1.57)	80 (3.15)	629 (24.76)	
	1PH7226		545 (21.46)			630 (24.80)				1050 (41.34)					729 (28.70)	
	1PH7228		635 (25.00)			720 (28.35)				1140 (44.88)					819 (32.24)	

Shaft height	Type	DIN IEC	Terminal box type 1XB7...			DE shaft extension							
			...322 p ¹⁾ HD	...422 p ¹⁾ HD	...700 p ¹⁾ HD	s K	w ₁ C	d D	d ₆ -	l E	t GA	u F	
180	1PH7184		495 (19.49)	-	-	14.5 (0.57)	121 (4.76)	60 (2.36)	M20	140 (5.51)	64 (2.52)	18 (0.71)	
	1PH7186			560 (22.05)	-			65 (2.56)			69 (2.72)		
225	1PH7224		595 (23.43)	645 (25.39)	680 (26.77)	18.5 (0.73)	149 (5.87)	75 (2.95)	M20	140 (5.51)	79.5 (3.13)	20 (0.79)	
	1PH7226												
	1PH7228												

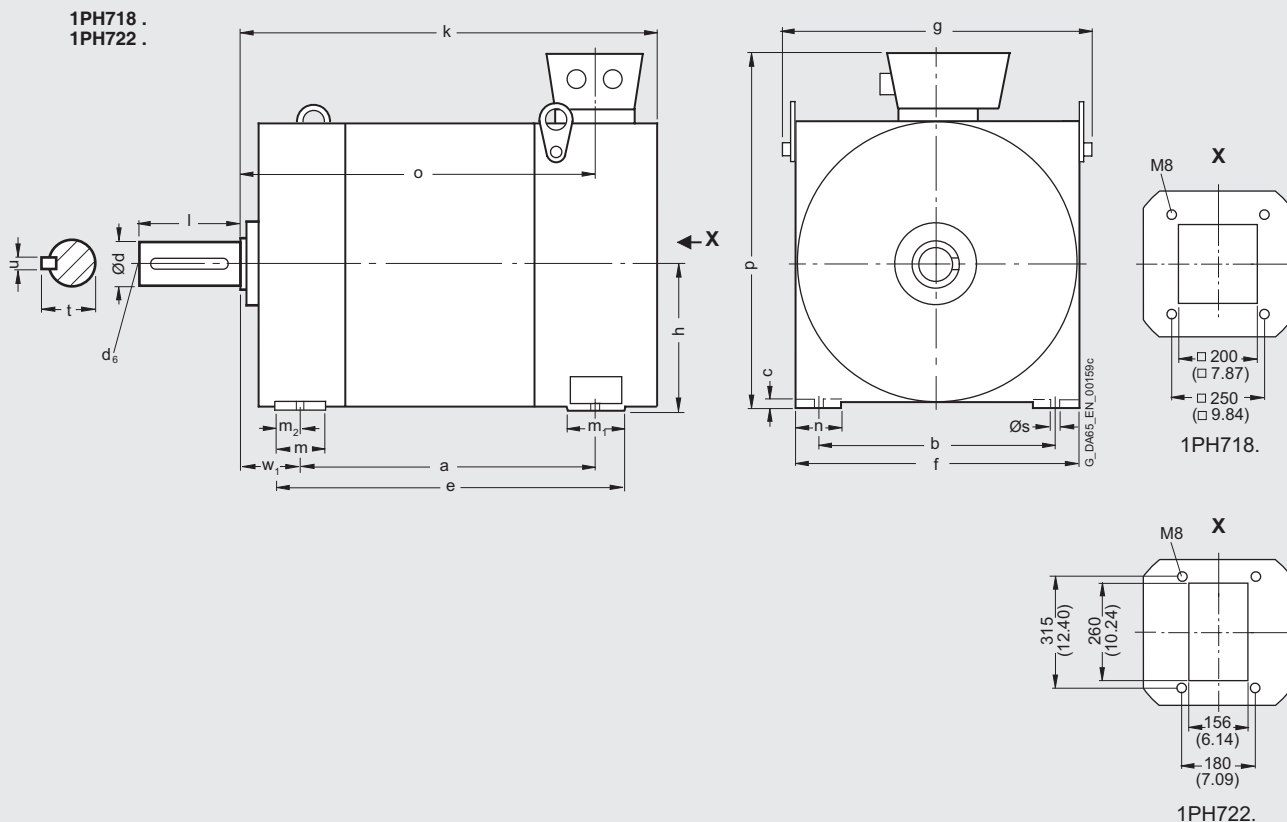

¹⁾ Maximum dimensions, depending on electrical version (terminal box type).

AC motors

Dimension drawings - asynchronous motors

1PH7 motors Forced ventilation

For motor		Dimensions in mm (in)															Terminal box type 1XB7...		
Shaft height	Type	DIN IEC	a	b	c	e	f	g	h	k	m	m ₁	m ₂	n	o	...322	...422	...700	
			B	A	LA	M	AB	AC	H	LB	BA	-	-	AA	-	p ¹⁾ HD	p ¹⁾ HD	p ¹⁾ HD	
Type IM B3, with external fan unit, with brake module, air-flow direction DE to NDE																			
180	1PH7184		430 (16.93)	279 (10.98)	14 (0.55)	510 (20.08)	360 (14.17)	408 (16.06)	180 (7.09)	945 (37.20)	60 (2.36)	120 (4.72)	35 (1.38)	65 (2.56)	644 (25.35)	495 (19.49)	-	-	-
	1PH7186		520 (20.47)			600 (23.62)				1035 (40.75)					734 (28.90)	560 (22.05)			
225	1PH7224		445 (17.52)	356 (14.02)	18 (0.71)	530 (20.87)	450 (17.72)	498 (19.61)	225 (8.86)	1230 (48.43)	60 (2.36)	120 (4.72)	40 (1.57)	80 (3.15)	758 (29.84)	595 (23.43)	645 (25.39)	680 (26.77)	
	1PH7226		545 (21.46)			630 (24.80)				1330 (52.36)					858 (33.78)				
	1PH7228		635 (25.00)			720 (28.35)				1420 (55.91)					948 (37.32)				

DE shaft extension

Shaft height	Type	DIN IEC	p _B	s	w ₁	d	d ₆	l	t	u
			-	K	C	D	-	E	GA	F
180	1PH7184		390 (15.35)	14.5 (0.57)	224 (8.82)	90 (3.54)	M20	90 (3.54)	95 (3.74)	25 (0.98)
	1PH7186									
225	1PH7224		450 (17.72)	18.5 (0.73)	278 (10.94)	100 (3.94)	M20	100 (3.94)	106 (4.17)	28 (1.10)
	1PH7226									
	1PH7228									

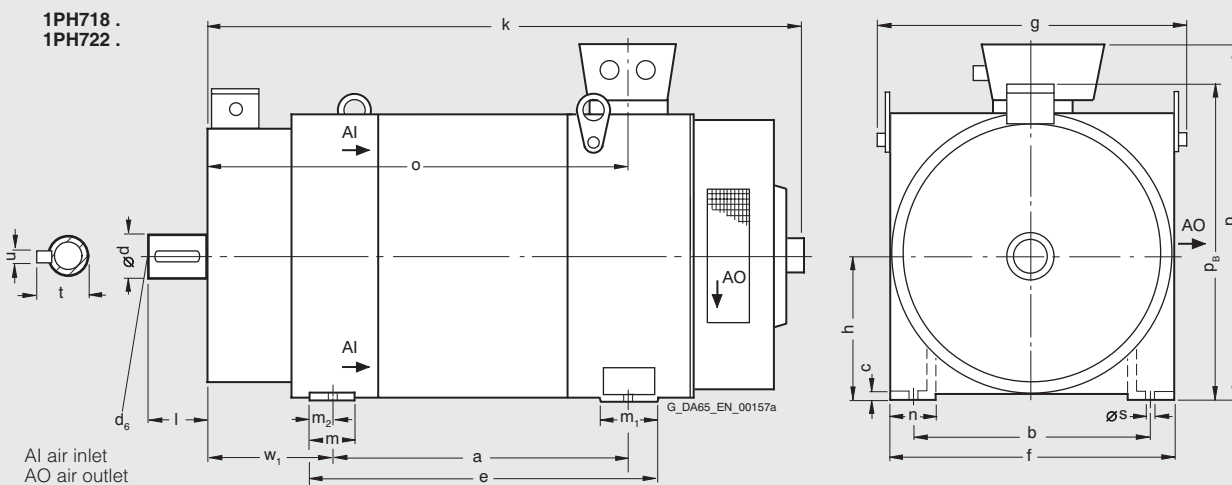

¹⁾ Maximum dimensions, depending on electrical version (terminal box type).

AC motors

Dimension drawings - asynchronous motors

1PH7 motors
Forced ventilation

For motor		Dimensions in mm (in)													DE shaft extension				
Shaft height	Type	DIN IEC	a ₁ P	b ₁ N	c ₁ LA	e ₁ M	f AB	f ₁ T	i ₂ -	k LB	k ₁ -	p HD	s ₂ S	s ₃ -	d D	d ₆ -	l E	t GA	u F
1PH7, type IM B5, forced ventilation																			
100	1PH7101		250 (9.84)	180 (7.09)	10 (0.39)	215 (8.46)	196 (7.72)	4 (0.16)	80 (3.15)	411 (16.18)	434 (17.09)	218 (8.58)	14 (0.55)	Pg 29	38 (1.50)	M12	80 (3.15)	41 (1.61)	10 (0.39)
	1PH7103																		
	1PH7105									506 (19.92)	529 (20.83)								
	1PH7107																		
132	1PH7131		350 (13.78)	250 (9.84)	16 (0.63)	300 (11.81)	260 (10.24)	5 (0.20)	110 (4.33)	538 (21.18)	561 (22.09)	273 (10.75)	18 (0.71)	Pg 36	42 (1.65)	M16	110 (4.33)	45 (1.77)	12 (0.47)
	1PH7133																		
	1PH7135									623 (24.53)	646 (25.43)								
	1PH7137																		

For deviating and additional dimensions for 1PH7 motors with DRIVE-CLiQ, see "1PH7 motors with DRIVE-CLiQ".

1PH710.
1PH713.

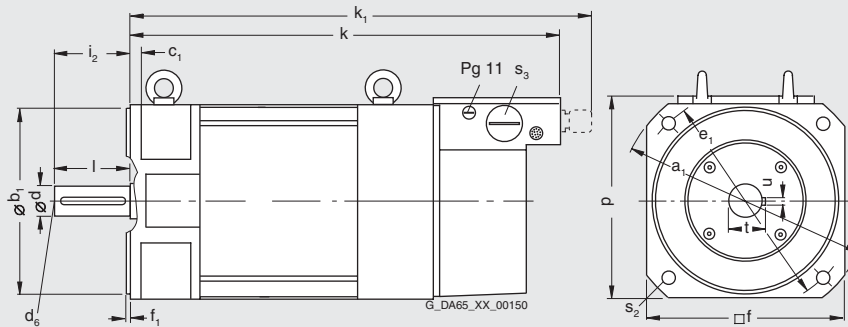

AC motors

Dimension drawings - asynchronous motors

1PH7 motors Forced ventilation

For motor Dimensions in mm (in)

Shaft height	Type	DIN IEC	a ₁ P	b ₁ N	c ₁ LA	e ₁ M	f AB	f ₁ T	i ₂ -	k LB	k ₁ -	o -	p HD	s ₂ S	s ₃ -	v -
--------------	------	---------	---------------------	---------------------	----------------------	---------------------	---------	---------------------	---------------------	---------	---------------------	--------	---------	---------------------	---------------------	--------

Type IM B5, with external fan unit, with pipe connection at NDE

100	1PH7101		250 (9.84)	180 (7.09)	10 (0.39)	215 (8.46)	196 (7.72)	4 (0.16)	80 (3.15)	441 (17.36)	411 (16.18)	161 (6.34)	120 (4.72)	14 (0.55)	Pg 29	10.5 (0.41)
	1PH7103									536 (21.10)	506 (19.92)					
	1PH7105															
	1PH7107															
132	1PH7131		350 (13.78)	250 (9.84)	16 (0.63)	300 (11.81)	260 (10.24)	5 (0.20)	110 (4.33)	573 (22.56)	538 (21.18)	211.5 (8.33)	143 (5.63)	18 (0.71)	Pg 36	17 (0.67)
	1PH7133									658 (25.91)	623 (24.53)					
	1PH7135															
	1PH7137															

DE shaft extension

Shaft height	Type	DIN IEC	d D	d ₆ -	l E	t GA	u F
--------------	------	---------	--------	---------------------	--------	---------	--------

100	1PH7101		38 (1.50)	M12	80 (3.15)	41 (1.61)	10 (0.39)
	1PH7103						
	1PH7105						
	1PH7107						
132	1PH7131		42 (1.65)	M16	110 (4.33)	45 (1.77)	12 (0.47)
	1PH7133						
	1PH7135						
	1PH7137						

For deviating and additional dimensions for 1PH7 motors with DRIVE-CLiQ, see "1PH7 motors with DRIVE-CLiQ".

1PH710.
1PH713.

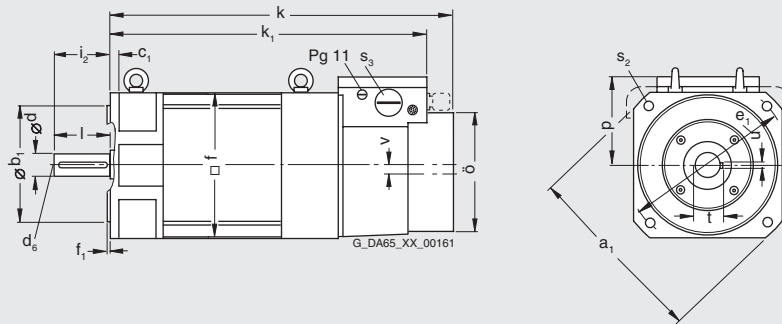

AC motors

Dimension drawings - asynchronous motors

1PH7 motors
Forced ventilation

For motor		Dimensions in mm (in)																
Shaft height	Type	DIN IEC	a ₁ P	b ₁ N	c ₁ LA	e ₁ M	f AB	f ₁ T	f ₂ -	g ₂ AB	g ₃ T	i ₂ -	k LB	k ₁ -	p HD	s ₂ S	s ₃ S	
Type IM B 5, with external fan unit, with brake module																		
100	1PH7101 1PH7103 1PH7105 1PH7107		250 (9.84)	180 (7.09)	13 (0.51)	215 (8.46)	196 (7.72)	4 (0.16)	220 (8.66)	149 (5.87)	224 (8.82)	80 (3.15)	541 (21.30)	564 (22.20)	120 (4.72)	14 (0.55)	Pg 29	
													636 (25.04)	659 (25.94)				
132	1PH7131 1PH7133 1PH7135 1PH7137		-	250 (9.84)	18 (0.71)	300 (11.81)	260 (10.24)	5 (0.20)	278 (10.94)	174 (6.85)	269 (10.59)	110 (4.33)	700 (27.56)	723 (28.46)	143 (5.63)	18 (0.71)	Pg 36	
													785 (30.91)	808 (31.81)				

DE shaft extension							
Shaft height	Type	DIN IEC	d D	d ₆ -	l E	t GA	u F
100	1PH7101 1PH7103 1PH7105 1PH7107		38 (1.50)	M12	80 (3.15)	1.61 (41)	0.39 (10)
132	1PH7131 1PH7133 1PH7135 1PH7137		42 (1.65)	M16	110 (4.33)	45 (1.77)	12 (0.47)

For deviating and additional dimensions for 1PH7 motors with DRIVE-CLiQ, see "1PH7 motors with DRIVE-CLiQ".

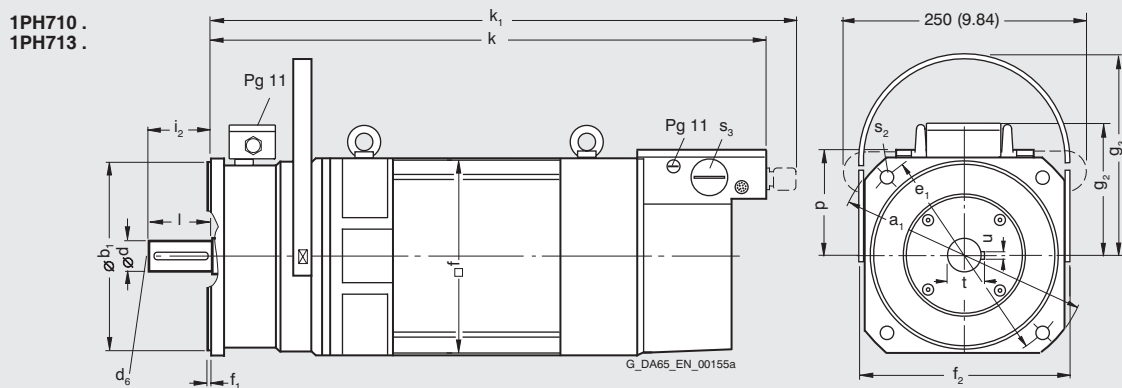

AC motors

Dimension drawings - asynchronous motors

1PH7 motors Forced ventilation

For motor		Dimensions in mm (in)																	
Shaft height	Type	DIN IEC	a B	a ₁ P	b A	b ₁ N	c LA	e ₁ M	f AB	f ₁ T	h H	i ₂ -	k LB	k ₁ -	m BA	m ₁ -	m ₂ -	n AA	p HD
1PH7, type IM B35, forced ventilation																			
100	1PH7101		202.5 (7.97)	250 (9.84)	160 (6.30)	180 (7.09)	11 (0.43)	215 (8.46)	196 (7.72)	4 (0.16)	100 (3.94)	80 (3.15)	411 (16.18)	435 (17.13)	52 (2.05)	64 (2.52)	27 (1.06)	39 (1.54)	220 (8.66)
	1PH7103																		
	1PH7105		297.5 (11.71)											506 (19.92)	529 (20.83)				
	1PH7107																		
132	1PH7131		265.5 (10.45)	350 (13.78)	216 (8.50)	250 (9.84)	14 (0.55)	300 (11.81)	260 (10.24)	5 (0.20)	132 (5.20)	110 (4.33)	538 (21.18)	561 (22.09)	63 (2.48)	75 (2.95)	33 (1.30)	52 (2.05)	275 (10.83)
	1PH7133																		
	1PH7135		350.5 (13.80)											623 (24.53)	646 (25.43)				
	1PH7137																		
160	1PH7163		346.5 (13.64)	400 (15.75)	254 (10.00)	300 (11.81)	17 (0.67)	350 (13.78)	314 (12.36)	5 (0.20)	160 (6.30)	110 (4.33)	640 (25.20)	663 (26.10)	78 (3.07)	81 (3.19)	42 (1.65)	62 (2.44)	330 (12.99)
	1PH7167		406.5 (16.00)										700 (27.56)	723 (28.46)					

DE shaft extension

Shaft height	Type	DIN IEC	n AA	p HD	s K	s ₂ S	s ₃ -	w ₁ C	d D	d ₆ -	l E	t GA	u F
100	1PH7101		39 (1.54)	220 (8.66)	12 (0.47)	14 (0.55)	Pg 29	40 (1.57)	38 (1.50)	M12	80 (3.15)	41 (1.61)	10 (0.39)
	1PH7103												
	1PH7105												
	1PH7107												
132	1PH7131		52 (2.05)	275 (10.83)	12 (0.47)	18 (0.71)	Pg 36	50 (1.97)	42 (1.65)	M16	110 (4.33)	45 (1.77)	12 (0.47)
	1PH7133												
	1PH7135												
	1PH7137												
160	1PH7163		62 (2.44)	330 (12.99)	14 (0.47)	18 (0.71)	Pg 42	64 (2.52)	55 (2.17)	M20	110 (4.33)	59 (2.32)	16 (0.63)
	1PH7167												

For deviating and additional dimensions for 1PH7 motors with DRIVE-CLiQ, see "1PH7 motors with DRIVE-CLiQ".

1PH710.
1PH713.
1PH716.

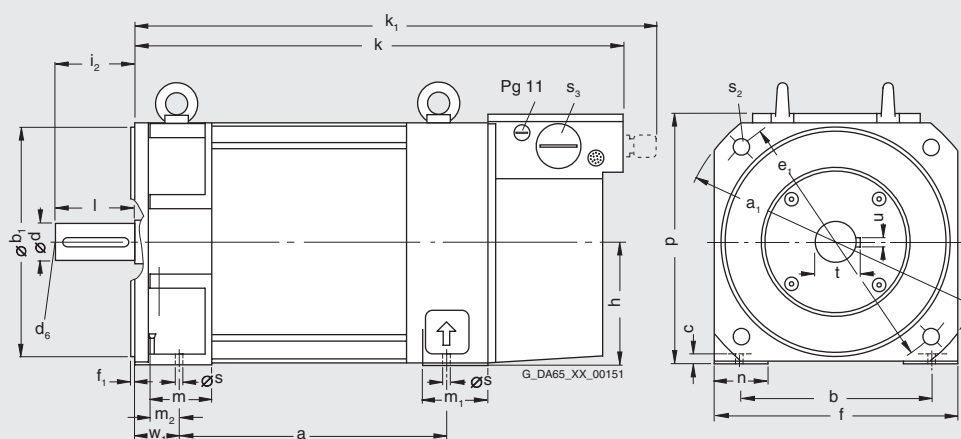

AC motors

Dimension drawings - asynchronous motors

1PH7 motors
Forced ventilation

For motor Dimensions in mm (in)

For dimensions of the shaft and terminal box foot installation, see dimension drawing of 1PH718. and 1PH722. motors type IM B3.

Terminal box type 1XB7...

Shaft height	Type	DIN IEC	a ₁ P	b ₁ N	c ₁ LA	e ₁ M	f ₁ T	h H	k LB	k ₁ -	...322 p ¹⁾	...422 p ¹⁾	...700 p ¹⁾	z -	α -
1PH7, type IM B35, forced ventilation, air-flow direction DE to NDE															
180	1PH7184 ²⁾		400 (15.75)	300 (11.81)	15 (0.59)	350 (13.78)	5 (0.20)	180 (7.09)	835 (32.87)	-	495 (19.49)	-	-	4	45°
	1PH7184 ²⁾		450 (17.72)	350 (13.78)	16 (0.63)	400 (15.75)			835 (32.87)					8	22.5°
	1PH7186								925 (36.42)			560 (22.05)	-		
225	1PH7224		550 (21.65)	450 (17.72)	18 (0.71)	500 (19.69)	5 (0.20)	225 (8.86)	-	1100 (43.31)	595 (23.43)	645 (25.39)	680 (26.77)	8	22.5°
	1PH7226									1200 (47.24)					
	1PH7228									1290 (50.79)					

1PH718 .
1PH722 .

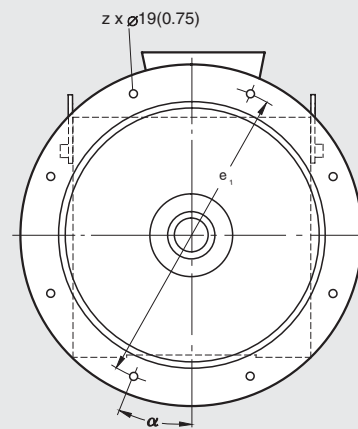
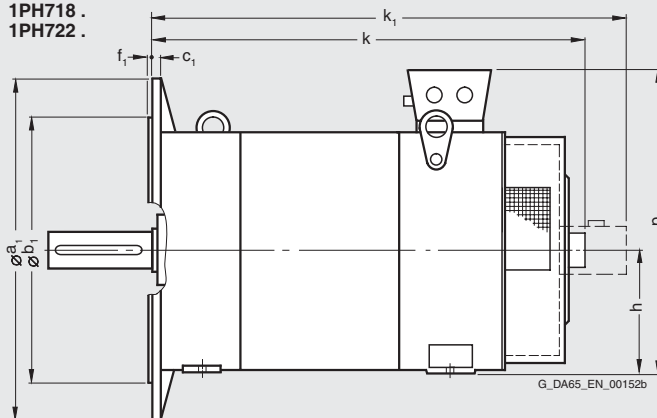

¹⁾ Maximum dimensions, depending on electrical version (terminal box type).

²⁾ See Order No. supplement for shaft heights 180 and 225.

AC motors

Dimension drawings - asynchronous motors

1PH7 motors Forced ventilation

For motor Dimensions in mm (in)

For dimensions of the shaft and terminal box foot installation, see dimension drawing of 1PH718. and 1PH722. motors type IM B3.

Terminal box type 1XB7...

Shaft height	Type	DIN IEC	a ₁ P	b ₁ N	c ₁ LA	e ₁ M	f ₁ T	h H	k LB	...322	...422	...700	z	α
										p ¹⁾	p ¹⁾	p ¹⁾		
1PH7, type IM B35, forced ventilation, air-flow direction NDE to DE														
180	1PH7184 ²⁾		400 (15.75)	300 (11.81)	15 (0.59)	350 (13.78)	5 (0.20)	180 (7.09)	1010 (39.76)	495 (19.49)	-	-	4	45°
	1PH7184 ²⁾		450 (17.72)	350 (13.78)	16 (0.63)	400 (15.75)			1010 (39.76)		-	-	8	22.5°
	1PH7186								1100 (43.31)		560 (22.05)	-		
225	1PH7224		550 (21.65)	450 (17.72)	18 (0.71)	500 (19.69)	5 (0.20)	225 (8.86)	1090 (42.91)	595 (23.43)	645 (25.39)	680 (26.77)	8	22.5°
	1PH7226								1190 (46.85)					
	1PH7228								1280 (50.39)		-			

1PH718 .

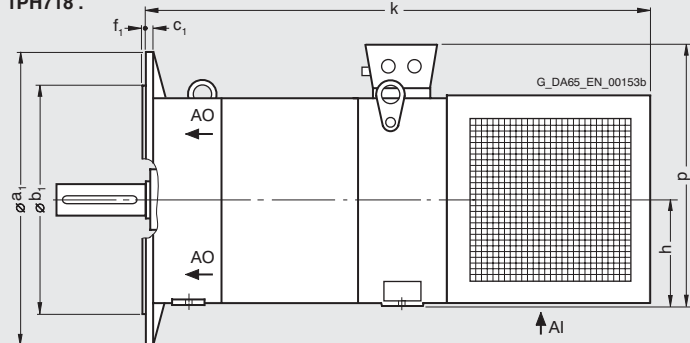

AI air inlet
AO air outlet

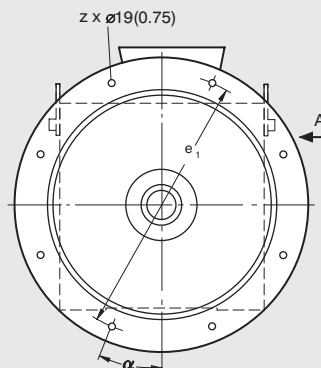

1PH722 .

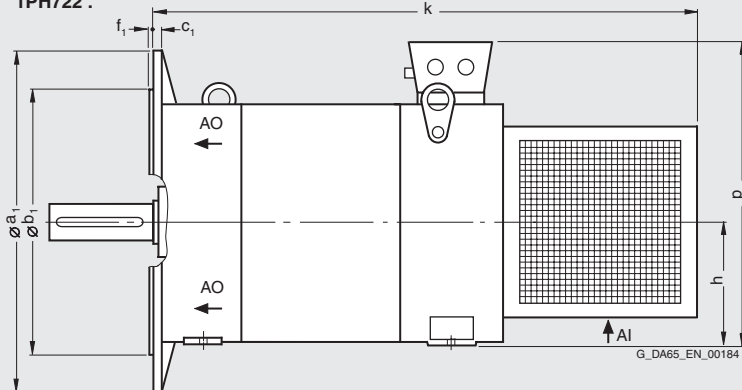

AI air inlet
AO air outlet

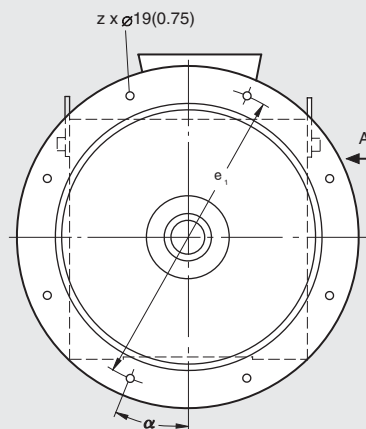

1) Maximum dimensions, depending on electrical version (terminal box type).

2) See Order No. supplement for shaft heights 180 and 225.

AC motors

Dimension drawings - asynchronous motors

1PH7 motors
Forced ventilation

For motor Dimensions in mm (in) For dimensions of the shaft and terminal box foot installation, see dimension drawing of 1PH728. motors type IM B 3.

Shaft height	Type	DIN IEC	a ₁ P	b ₁ N	c ₁ LA	e ₁ M	f ₁ T	h H	i ₂ -	k LB	k ₁ -	k ₂ -	p ₂ -
Type IM B 35, with external fan unit, air-flow direction NDE to DE													
280	1PH7284		660 (25.98)	550 (21.65)	24 (0.94)	600 (23.62)	6 (0.24)	280 (11.02)	170 (6.69)	1146 (45.12)	489 (19.25)	546 (21.50)	1042 (41.02)
	1PH7286									1256 (49.45)	599 (23.58)		
	1PH7288									1386 (54.57)	729 (28.70)		

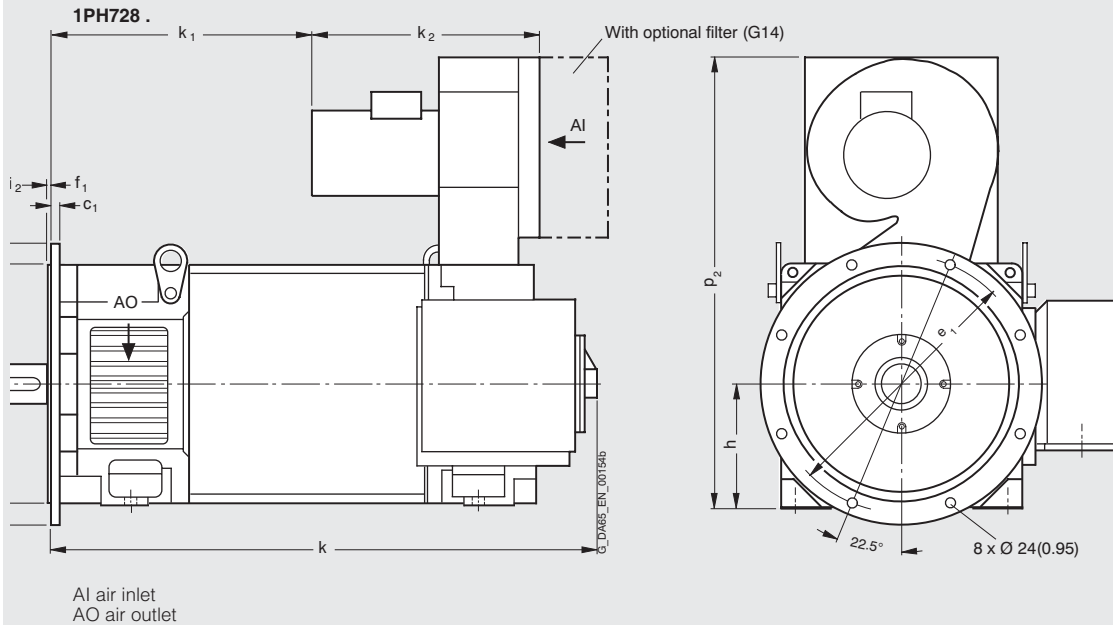

3

AC motors

Dimension drawings - asynchronous motors

1PH7 motors Forced ventilation

For motor		Dimensions in mm (in)																
Shaft height	Type	DIN IEC	a B	a ₁ P	b A	b ₁ N	c LA	c ₁ -	e ₁ -	f AB	f ₁ T	h H	k LB	k ₁ -	m BA	m ₁ -	m ₂ -	
Type IM B35, with external fan unit, with pipe connection at NDE																		
100	1PH7101		202.5 (7.97)	250 (9.84)	160 (6.30)	180 (7.09)	11 (0.43)	13 (0.51)	215 (8.46)	196 (7.72)	4 (0.16)	100 (3.94)	441 (17.36)	411 (16.18)	52 (2.05)	64 (2.52)	25 (0.98)	
	1PH7103												536 (21.10)	506 (19.92)				
	1PH7105		297.5 (11.71)															
	1PH7107																	
132	1PH7131		265.5 (10.45)	350 (13.78)	216 (8.50)	250 (9.84)	14 (0.55)	17 (0.67)	300 (11.81)	260 (10.24)	5 (0.20)	132 (5.20)	573 (22.56)	538 (21.18)	63 (2.48)	75 (2.95)	30 (1.18)	
	1PH7133												658 (25.91)	623 (24.53)				
	1PH7135		350.5 (13.80)															
	1PH7137																	
160	1PH7163		346.5 (13.64)	400 (15.75)	254 (10.00)	300 (11.81)	17 (0.67)	22 (0.87)	350 (13.78)	314 (12.36)	5 (0.20)	160 (6.30)	674 (26.54)	640 (25.20)	78 (3.07)	81 (3.19)	36 (1.42)	
	1PH7167		406.5 (16.00)										734 (28.90)	700 (27.56)				

DE shaft extension

Shaft height	Type	DIN IEC	n AA	o -	p HD	s K	s ₂ K	s ₃ -	v -	w ₁ C	d D	d ₆ -	l E	t GA	u F
100	1PH710 .		39 (1.54)	161 (6.34)	220 (8.66)	12 (0.47)	14 (0.55)	Pg 29	10.5 (0.41)	40 (1.57)	38 (1.50)	M12	80 (3.15)	41 (1.61)	10 (0.39)
132	1PH713 .		52 (2.05)	211.5 (8.33)	275 (10.83)	12 (0.47)	18 (0.71)	Pg 36	17 (0.67)	50 (1.97)	42 (1.65)	M16	110 (4.33)	45 (1.77)	12 (0.47)
160	1PH716 .		62 (2.44)	253 (9.96)	330 (12.99)	14 (0.55)	18 (0.71)	Pg 42	17 (0.67)	64 (2.52)	55 (2.17)	M20	110 (4.33)	59 (2.32)	16 (0.63)

For deviating and additional dimensions for 1PH7 motors with DRIVE-CLiQ, see "1PH7 motors with DRIVE-CLiQ".

1PH710 .
1PH713 .
1PH716 .

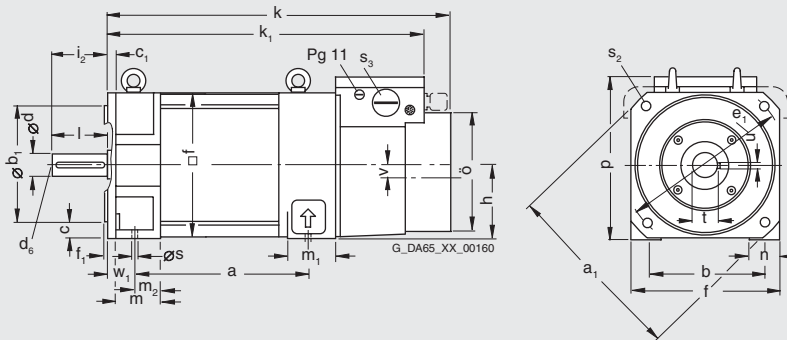

AC motors

Dimension drawings - asynchronous motors

1PH7 motors
Forced ventilation

For motor		Dimensions in mm (in)																
Shaft height	Type	DIN IEC	a B	a ₁ P	b A	b ₁ N	c LA	e ₁ M	f AB	f ₁ T	f ₂ -	g ₂ -	g ₃ -	h H	i ₂ -	k LB	k ₁ -	
Type IM B 35, with external fan unit, with brake module																		
100	1PH7101		202.5 (7.97)	250 (9.84)	160 (6.30)	180 (7.09)	11 (0.43)	215 (8.46)	196 (7.72)	4 (0.16)	220 (8.66)	149 (5.87)	224 (8.82)	100 (3.94)	80 (3.15)	541 (21.30)	564 (22.20)	
	1PH7103																	
	1PH7105		297.5 (11.71)														636 (25.04)	659 (25.94)
	1PH7107																	
132	1PH7131		265.5 (10.45)	-	216 (8.50)	250 (9.84)	14 (0.55)	300 (11.81)	260 (10.24)	5 (0.20)	278 (10.94)	174 (6.85)	269 (10.59)	132 (5.20)	110 (4.33)	700 (27.56)	723 (28.46)	
	1PH7133																	
	1PH7135		350.5 (13.80)														785 (30.91)	808 (31.81)
	1PH7137																	
160	1PH7163		346.5 (13.64)	400 (15.75)	254 (10.00)	300 (11.81)	17 (0.67)	350 (13.78)	314 (12.36)	5 (0.20)	327 (12.87)	199 (7.83)	328 (12.91)	160 (6.30)	110 (4.33)	808 (31.81)	831 (32.72)	
	1PH7167		406.5 (16.00)													868 (34.17)	891 (35.08)	

		DE shaft extension															
Shaft height	Type	DIN IEC	m BA	m ₁ -	m ₂ -	n AA	p -	s K	s ₂ -	s ₃ -	w ₁ C	d D	d ₆ -	l E	t GA	u F	
100	1PH7101		52 (2.05)	64 (2.52)	27 (1.06)	39 (1.54)	220 (8.66)	12 (0.47)	14 (0.55)	Pg 29	170 (6.69)	38 (1.50)	M12	80 (3.15)	41 (1.61)	10 (0.39)	
	1PH7103																
	1PH7105																
	1PH7107																
132	1PH7131		63 (2.48)	75 (2.95)	33 (1.30)	52 (2.05)	275 (10.83)	12 (0.47)	18 (0.71)	Pg 36	212 (8.35)	42 (1.65)	M16	110 (4.33)	45 (1.77)	12 (0.47)	
	1PH7133																
	1PH7135																
	1PH7137																
160	1PH7163		78 (3.07)	81 (3.19)	42 (1.65)	62 (2.44)	330 (12.99)	14 (0.55)	18 (0.71)	Pg 42	232 (9.13)	55 (2.17)	M20	110 (4.33)	59 (2.32)	16 (0.63)	
	1PH7167																

For deviating and additional dimensions for 1PH7 motors with DRIVE-CLiQ, see "1PH7 motors with DRIVE-CLiQ".

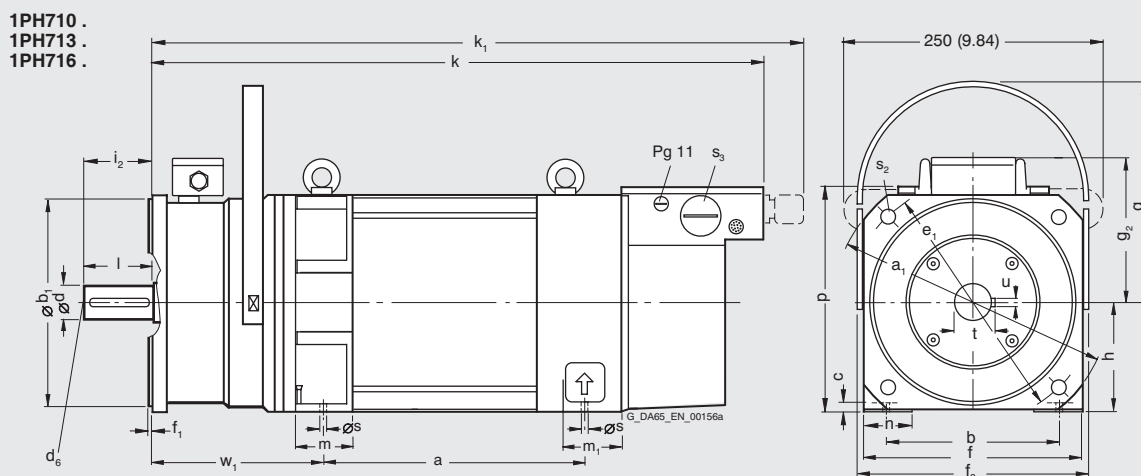

AC motors

Dimension drawings - asynchronous motors

1PH7 motors with DRIVE-CLiQ Forced ventilation

For motor Dimensions in mm (in)

Shaft height	Type	DIN IEC	k LB	k ₁ -	p ₁ -	x -	y -
--------------	------	---------	------	------------------	------------------	-----	-----

Deviating and additional dimensions for 1PH7 motors with DRIVE-CLiQ to those given in dimension tables 1PH7, forced ventilation

100	1PH7101		411 (16.18)	453 (17.83)	81 (3.19)	52.5 (2.07)	63.5 (2.50)
	1PH7103						
	1PH7105		506 (19.92)	548 (21.57)			
	1PH7107						
132	1PH7131		538 (21.18)	580 (22.83)	103.5 (4.07)	66 (2.60)	63.5 (2.50)
	1PH7133						
	1PH7135		623 (24.53)	665 (26.18)			
	1PH7137						
160	1PH7163		640 (25.20)	682 (26.85)	127 (5.00)	75 (2.95)	63.5 (2.50)
	1PH7167		700 (27.56)	742 (29.21)			

1PH710 .
1PH713 .
1PH716 .

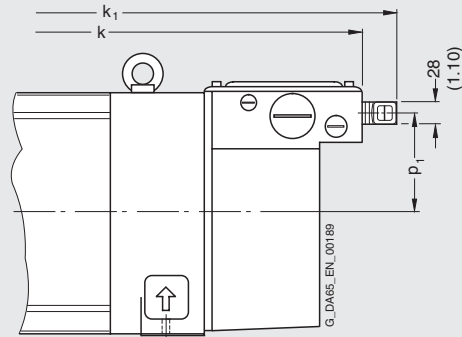
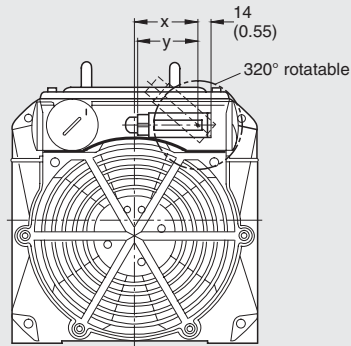

AC motors

Dimension drawings - asynchronous motors

1PL6 motors
Forced ventilation

For motor		Dimensions in mm (in)														
Shaft height	Type	DIN IEC	a B	b A	c LA	e M	f AB	g AC	h H	k LB	k ₁ -	m BA	m ₁ -	m ₂ -	n AA	o -
Type IM B3, forced ventilation, air-flow direction DE to NDE																
180	1PL6184		430 (16.93)	279 (10.98)	14 (0.55)	525 (20.67)	360 (14.17)	405 (15.94)	180 (7.09)	835 (32.87)	-	78 (3.07)	120 (4.72)	50 (1.97)	65 (2.56)	541 (21.30)
	1PL6186		520 (20.47)			615 (24.21)				925 (36.42)						631 (24.84)
225	1PL6224		445 (17.52)	356 (14.02)	18 (0.71)	545 (21.46)	450 (17.72)	498 (19.61)	225 (8.86)	-	1100 (43.31)	80 (3.15)	120 (4.72)	60 (2.36)	85 (3.35)	629 (24.76)
	1PL6226		545 (21.46)			645 (25.39)					1200 (47.24)					729 (28.70)
	1PL6228		635 (25.00)			735 (28.94)					1290 (50.79)					819 (32.24)

Shaft height	Type	DIN IEC	Terminal box type 1XB7...			DE shaft extension						
			...322 p ¹⁾ HD	...422 p ¹⁾ HD	...700 p ¹⁾ HD	s K	w ₁ C	d D	d ₆ -	l E	t GA	u F
180	1PL6184		495 (19.49)	560 (22.05)	-	14.5 (0.57)	121 (4.76)	60 (2.36)	M20	140 (5.51)	64 (2.52)	18 (0.71)
	1PL6186			580 (22.83)				65 (2.56)			69 (2.72)	
225	1PL6224		595 (23.43)	645 (25.39)	680 (26.77)	18.5 (0.73)	149 (5.87)	75 (2.95)	M20	140 (5.51)	79.5 (3.13)	20 (0.79)
	1PL6226			-								
	1PL6228			-								

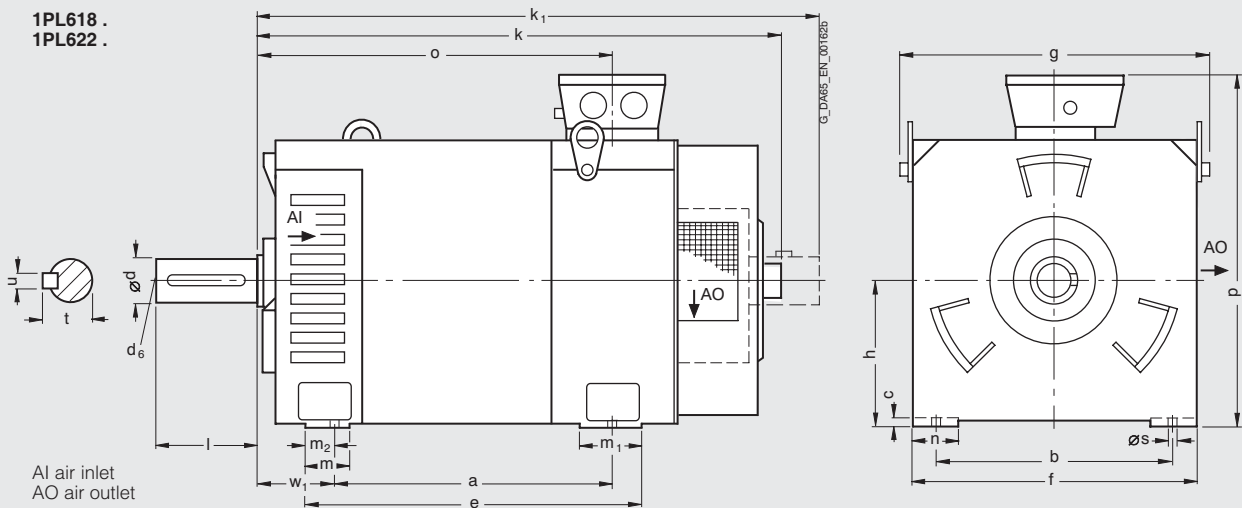

¹⁾ Maximum dimensions, depending on electrical version (terminal box type).

AC motors

Dimension drawings - asynchronous motors

1PL6 motors Forced ventilation

For motor		Dimensions in mm (in)															Terminal box type 1XB7... ...422 ...700	
Shaft height	Type	DIN IEC	a B	b A	c LA	e M	f AB	g AC	h H	k LB	m BA	m ₁ -	m ₂ -	n AA	o -	p ¹⁾ HD	p ¹⁾ HD	
Type IM B3, with external fan unit, with pipe connection at NDE																		
180	1PL6184		430 (16.93)	279 (10.98)	14 (0.55)	510 (20.08)	360 (14.17)	408 (16.06)	180 (7.09)	630 (24.80)	60 (2.36)	120 (4.72)	35 (1.38)	65 (2.56)	541 (21.30)	560 (22.05)	-	
	1PL6186		520 (20.47)			600 (23.62)				720 (28.35)					631 (24.84)		680 (26.77)	
225	1PL6224		445 (17.52)	356 (14.02)	18 (0.71)	530 (20.78)	450 (17.72)	498 (19.61)	225 (8.86)	750 (29.53)	60 (2.36)	120 (4.72)	40 (1.57)	80 (3.15)	629 (24.76)	-	680 (26.77)	
	1PL6226		545 (21.46)			630 (24.80)				850 (33.46)					729 (28.70)			
	1PL6228		635 (25.00)			720 (28.35)				940 (37.01)					819 (32.24)			

DE shaft extension

Shaft height	Type	DIN IEC	s K	w ₁ C	d D	d ₆ -	l E	t GA	u F
180	1PL6184		14.5 (0.57)	121 (4.76)	60 (2.36)	M20	140 (5.51)	64 (2.52)	18 (0.71)
	1PL6186				65 (2.56)			69 (2.72)	
225	1PL6224		18.5 (0.73)	149 (5.87)	75 (2.95)	M20	140 (5.51)	79.5 (3.13)	20 (0.79)
	1PL6226								
	1PL6228								

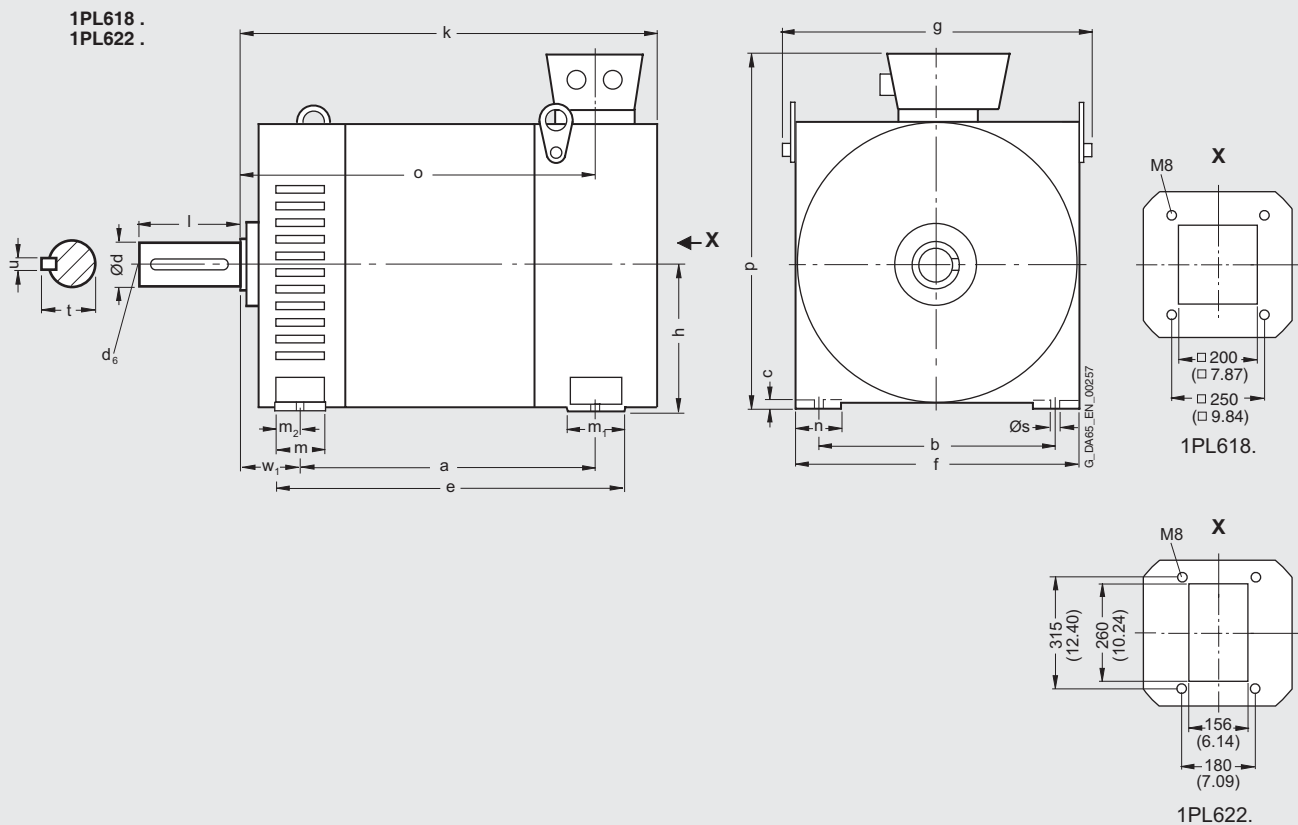

¹⁾ Maximum dimensions, depending on electrical version (terminal box type).

AC motors Dimension drawings - asynchronous motors

**1PL6 motors
Forced ventilation**

For motor		Dimensions in mm (in)															Terminal box type 1XB7...		
Shaft height	Type	DIN IEC	a	b	c	e	f	g	h	k	m	m ₁	m ₂	n	o	p ¹⁾	p ¹⁾	p ¹⁾	
			B	A	LA	M	AB	AC	H	LB	BA	-	-	AA	-	HD	HD	HD	
Type IM B3, forced ventilation, air-flow direction NDE to DE																			
180	1PL6184		430 (16.93)	279 (10.98)	14 (0.55)	525 (20.67)	360 (14.17)	405 (15.94)	180 (7.09)	1010 (39.76)	78 (3.07)	120 (4.72)	50 (1.97)	65 (2.56)	541 (21.30)	495 (19.49)	560 (22.05)	-	-
	1PL6186		520 (20.47)			615 (24.21)				1100 (43.31)					631 (24.84)		580 (22.83)		
225	1PL6224		445 (17.52)	356 (14.02)	18 (0.71)	545 (21.46)	450 (17.72)	498 (19.61)	225 (8.86)	1090 (42.91)	80 (3.15)	120 (4.72)	60 (2.36)	85 (3.35)	629 (24.76)	595 (23.43)	645 (25.39)	680 (26.77)	
	1PL6226		545 (21.46)			645 (25.39)				1190 (46.85)					729 (28.70)		-		
	1PL6228		635 (25.00)			735 (28.94)				1280 (50.39)					819 (32.24)		-		

For motor		DE shaft extension							
Shaft height	Type	DIN IEC	s	w ₁	d	d ₆	l	t	u
			K	C	D	-	E	GA	F
180	1PL6184		14.5 (0.57)	121 (4.76)	60 (2.36)	M20	140 (5.51)	64 (2.52)	18 (0.71)
	1PL6186				65 (2.56)			69 (2.72)	
225	1PL6224		18.5 (0.73)	149 (5.87)	75 (2.95)	M20	140 (5.51)	79.5 (3.13)	20 (0.79)
	1PL6226								
	1PL6228								

1PL618 .

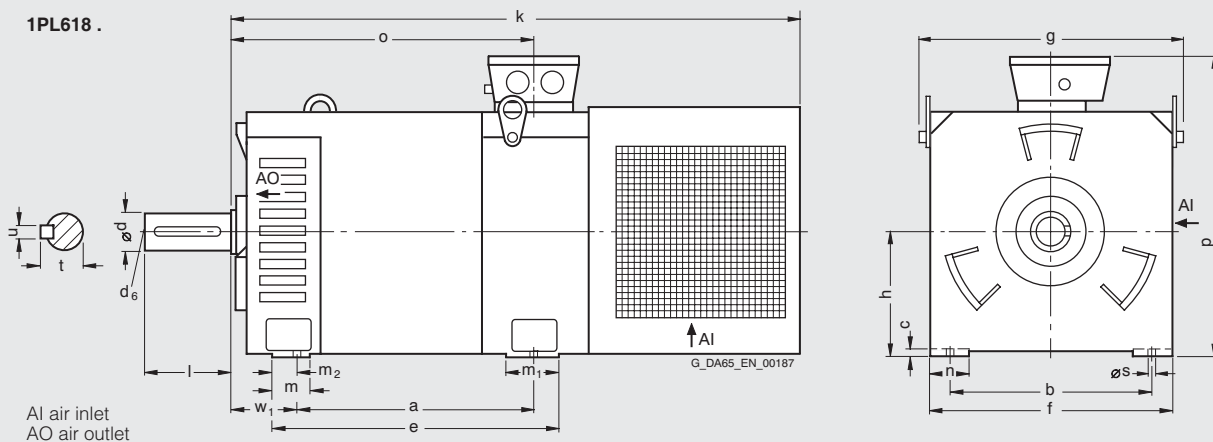

1PL622 .

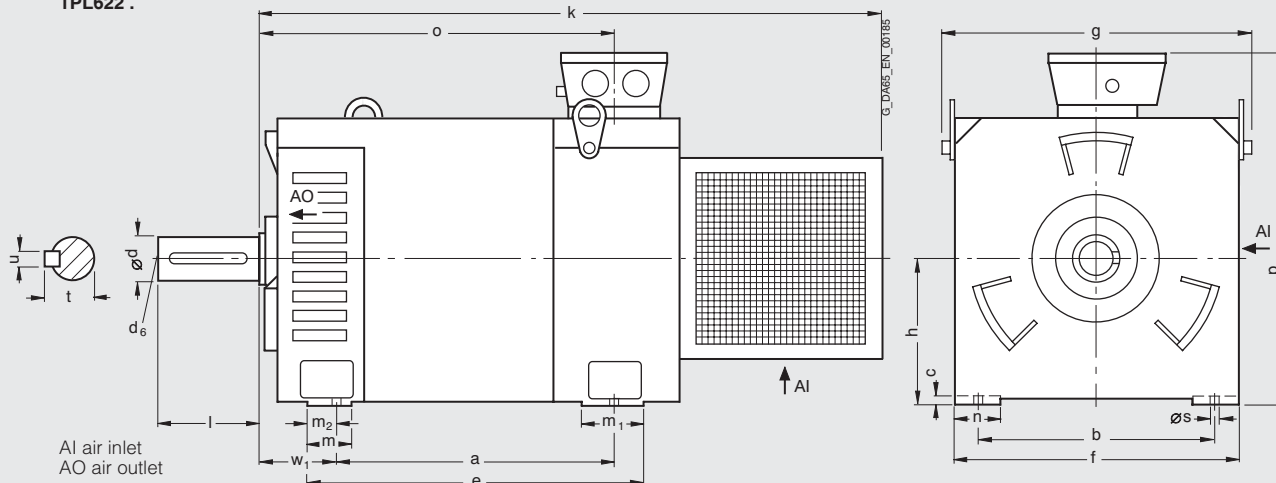

¹⁾ Maximum dimensions, depending on electrical version (terminal box type).

AC motors

Dimension drawings - asynchronous motors

1PL6 motors Forced ventilation

For motor Dimensions in mm (in)

Shaft height	Type	DIN IEC	a B	b A	c HA	e BB	f AB	g ₂ AD	g ₄ -	h H	k LB	k ₁ -	k ₂ -	m ₁ -	m ₂ -	n AA
Type IM B 3, forced ventilation, air-flow direction NDE to DE																
280	1PL6284		684 (26.93)	457 (17.99)	22 (0.87)	840 (33.07)	560 (22.05)	518 (20.39)	449 (17.68)	280 (11.02)	1146 (45.12)	489 (19.25)	546 (21.50)	108 (4.25)	78 (3.07)	100 (3.94)
	1PL6286		794 (31.26)			950 (37.40)					1256 (49.45)	599 (23.58)				
	1PL6288		924 (36.38)			1080 (42.52)					1386 (54.57)	729 (28.70)				

DE shaft extension

Shaft height	Type	DIN IEC	o -	p ₂ -	s K	w ₁ C	d D	l E	t GA	u F
280	1PL6284		731 (28.78)	1042 (41.02)	24 (0.94)	190 (7.48)	95 (3.74)	170 (6.69)	100 (3.94)	25 (0.98)
	1PL6286		841 (33.11)							
	1PL6288		971 (38.23)							

1PL628 .

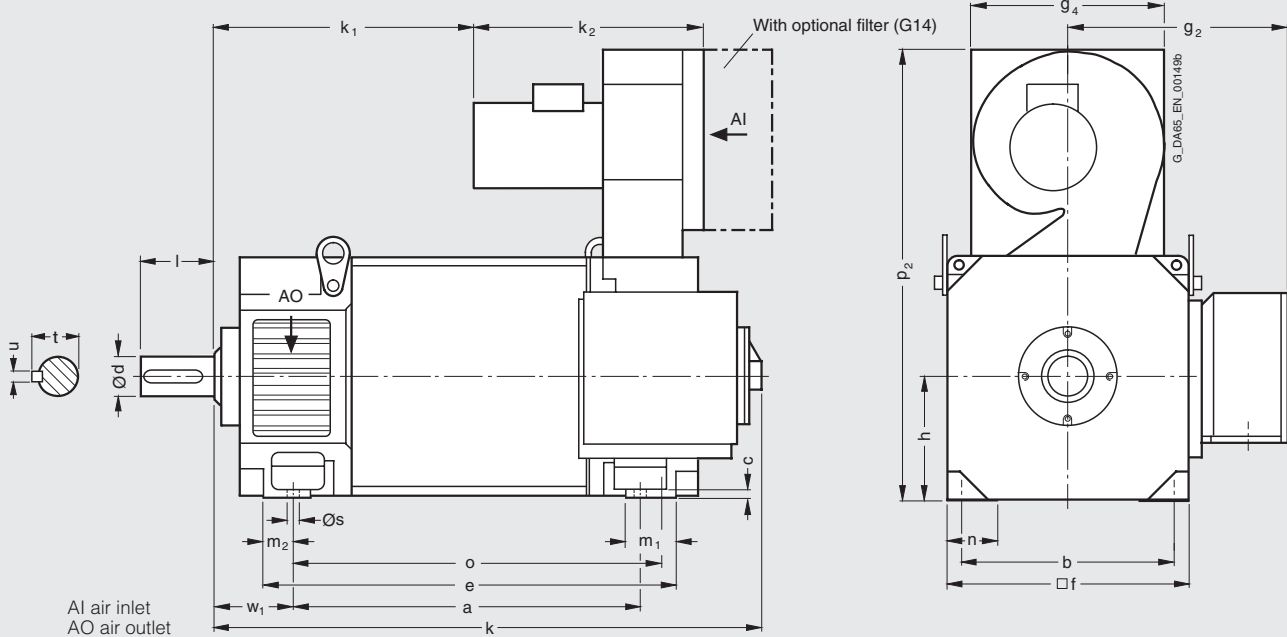

AC motors

Dimension drawings - asynchronous motors

1PL6 motors
Forced ventilation

For motor		Dimensions in mm (in)										For dimensions of the shaft and terminal box foot installation, see dimension drawing of 1PL618. and 1PL622. motors type IM B 3.
Shaft height	Type	DIN IEC	a ₁ P	b ₁ N	c ₁ LA	e ₁ M	f ₁ T	i ₂ -	s ₂ S	z -	w ₁ -	
Type IM B 35, forced ventilation, air-flow direction DE to NDE												
180	1PL6184		450 (17.72)	350 (13.78)	16 (0.63)	400 (15.75)	5 (0.20)	140 (5.51)	19 (0.75)	8	121 (4.76)	
	1PL6186											
225	1PL6224		550 (21.65)	450 (17.72)	18 (0.71)	500 (19.69)	5 (0.20)	140 (5.51)	19 (0.75)	8	149 (5.87)	
	1PL6226											
	1PL6228											

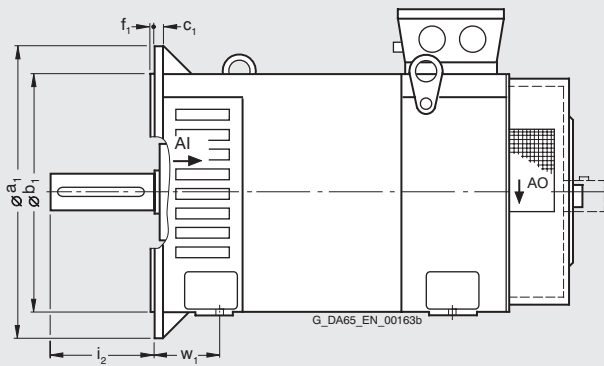

AI air inlet
AO air outlet

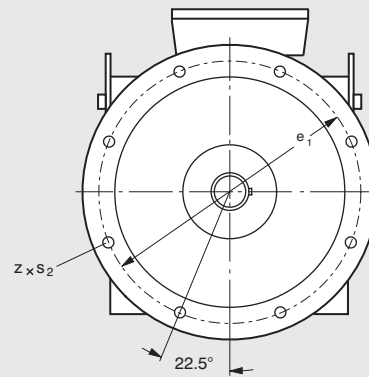

3

AC motors

Dimension drawings - asynchronous motors

1PL6 motors Forced ventilation

For motor Dimensions in mm (in)

For dimensions of the shaft and terminal box foot installation, see dimension drawing of 1PL618. and 1PL622. motors type IM B 3.

Terminal box type 1XB7...

...322 ...422 ...700

Shaft height	Type	DIN IEC	a ₁ P	b ₁ N	c ₁ LA	e ₁ M	f ₁ T	h H	k LB	p ¹⁾ HD	p ¹⁾ HD	p ¹⁾ HD	s ₂ S	z -	α -
Type IM B 35, forced ventilation, air-flow direction NDE to DE															
180	1PL6184		450 (17.72)	350 (13.78)	16 (0.63)	400 (15.75)	5 (0.20)	180 (7.09)	1010 (39.76)	495 (19.49)	560 (22.05)	-	19 (0.75)	8	22.5°
	1PL6186								1100 (43.31)			580 (22.83)			
225	1PL6224		550 (21.65)	450 (17.72)	18 (0.71)	500 (19.69)	5 (0.20)	225 (8.86)	1090 (42.91)	595 (23.43)	645 (25.39)	680 (26.77)	19 (0.75)	8	22.5°
	1PL6226								1190 (46.85)						
	1PL6228								1280 (50.39)						

1PL618 .

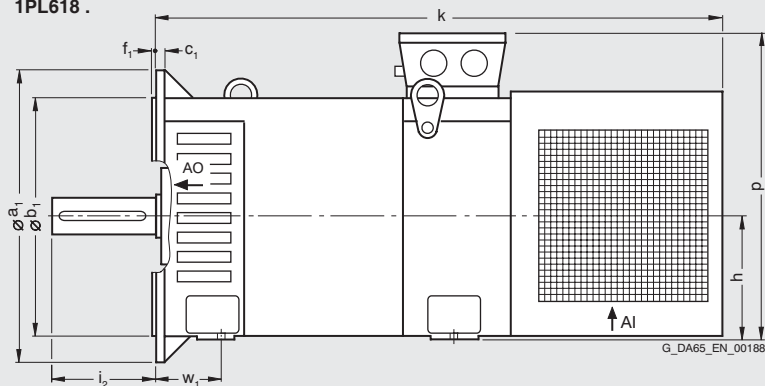

AI air inlet
AO air outlet

1PL622 .

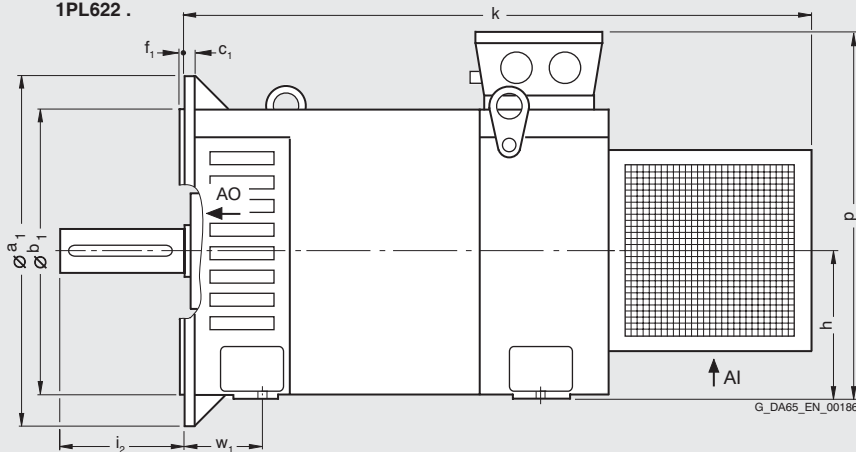

AI air inlet
AO air outlet

¹⁾ Maximum dimensions, depending on electrical version (terminal box type).

AC motors

Dimension drawings - asynchronous motors

1PL6 motors
Forced ventilation

For motor Dimensions in mm (in) For dimensions of the shaft and terminal box foot installation, see dimension drawing of 1PL628. motors type IM B 3.

Shaft height	Type	DIN IEC	a ₁ P	b ₁ N	c ₁ LA	e ₁ M	f ₁ T	h H	i ₂ -	k LB	k ₁ -	k ₂ -	p ₂ -
Type IM B 35, forced ventilation, air-flow direction NDE to DE													
280	1PL6284		660 (25.98)	550 (21.65)	24 (0.94)	600 (23.62)	6 (0.24)	280 (11.02)	170 (6.69)	1146 (45.12)	489 (19.25)	546 (21.50)	1042 (41.02)
	1PL6286									1256 (49.45)		599 (23.58)	
	1PL6288									1386 (54.57)		729 (28.70)	

1PL628 .

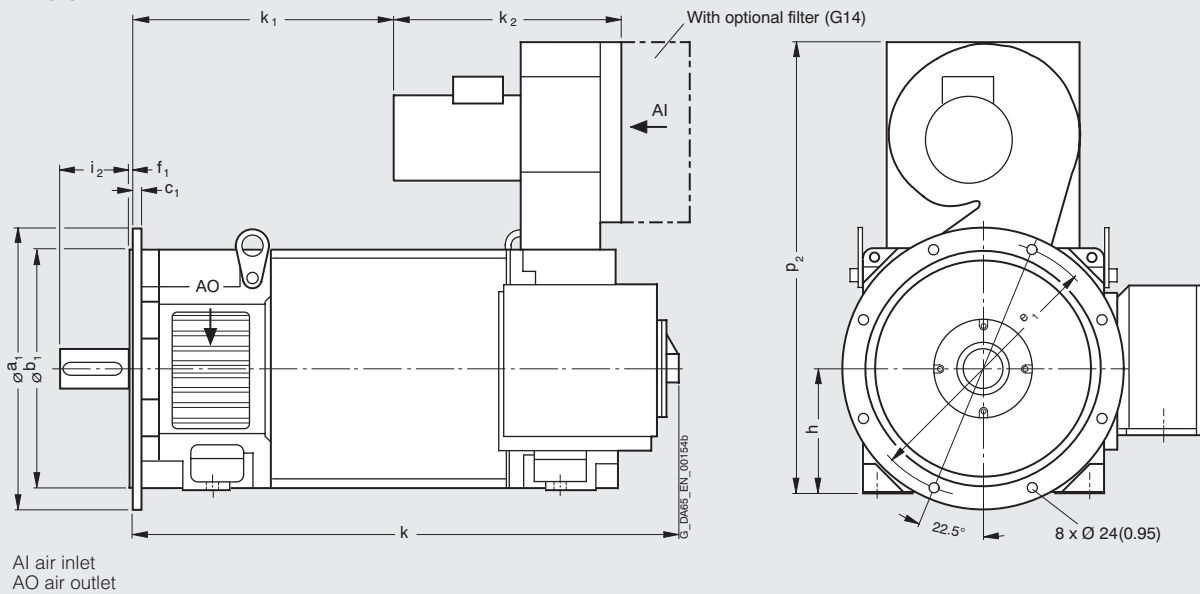

3

AC motors

Dimension drawings - asynchronous motors

1PH4 motors Water cooling

For motor		Dimensions in mm (in)																	
Shaft height	Type	DIN IEC	a B	a ₁ P	b A	b ₁ N	c LA	c ₁ -	e ₁ -	f AB	f ₁ T	h H	i ₂ -	k LB	m BA	m ₁ -	m ₂ -	n AA	
1PH4, type IM B35, water cooling																			
100	1PH4103		349 (13.74)	250 (9.84)	160 (6.30)	180 (7.09)	11 (0.43)	12 (0.47)	215 (8.46)	190 (7.48)	4 (0.16)	100 (3.94)	80 (3.15)	416 (16.38)	35 (1.38)	60 (2.36)	24 (0.94)	40 (1.57)	
	1PH4105		409 (16.10)											476 (18.74)					
	1PH4107		474 (18.66)												541 (21.30)				
132	1PH4133		377 (14.84)	350 (13.78)	216 (8.50)	250 (9.84)	14 (0.55)	16 (0.63)	300 (11.81)	245 (9.65)	5 (0.20)	132 (5.20)	110 (4.33)	458 (18.03)	36 (1.42)	85 (3.35)	24 (0.94)	43 (1.69)	
	1PH4135		447 (17.60)											528 (20.79)					
	1PH4137		497 (19.57)											578 (22.76)					

DE shaft extension

Shaft height	Type	DIN IEC	o -	p HD	s K	s ₂ K	s ₃ -	w ₁ C	d D	d ₆ -	l E	t GA	u F
100	1PH4103		244 (9.61)	259 (10.20)	12 (0.47)	14 (0.55)	Pg 29	44 (1.73)	38 (1.50)	M12	80 (3.15)	41 (1.61)	10 (0.39)
	1PH4105		304 (11.97)										
	1PH4107		369 (14.53)										
132	1PH4133		264 (10.39)	334.5 (13.17)	12 (0.47)	18 (0.71)	Pg 36	53 (2.09)	42 (1.77)	M16	110 (4.33)	45 (1.77)	12 (0.47)
	1PH4135		334 (13.15)										
	1PH4137		384 (15.12)										

1PH410.
1PH413.

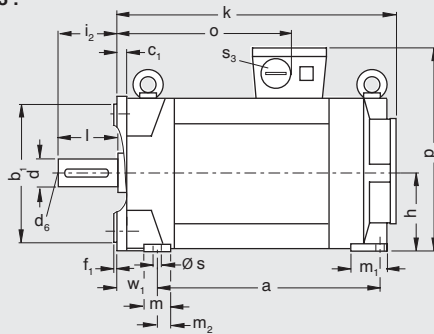

Water connection
G 1/4 for 1PH410.
G 3/8 for 1PH413.

Water connection
G 1/4 for 1PH410.
G 3/8 for 1PH413.

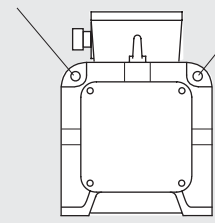
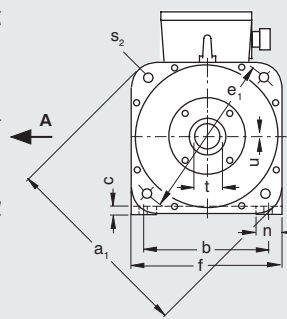

G_DA65_EN_00164b

A

AC motors

Dimension drawings - asynchronous motors

1PH4 motors
Water cooling

For motor		Dimensions in mm (in)																	
Shaft height	Type	DIN IEC	a B	a ₁ P	b A	b ₁ N	c LA	c ₁ -	e ₁ -	f AB	f ₁ T	h H	i ₂ -	k LB	m BA	m ₁ -	m ₂ -	n AA	
1PH4, type IM B35, water cooling																			
160	1PH4163		508 (20.00)	400 (15.75)	254 (10.00)	300 (11.81)	15 (0.59)	18 (0.71)	350 (13.78)	294 (11.57)	5 (0.20)	160 (6.30)	110 (4.33)	591 (23.27)	44 (1.73)	77 (3.03)	29 (1.14)	49 (1.93)	
	1PH4167		563 (22.17)											646 (25.43)					
	1PH4168		608 (23.94)											691 (27.20)					

		DE shaft extension												
Shaft height	Type	DIN IEC	o -	p HD	s K	s ₂ K	s ₃ -	w ₁ C	d D	d ₆ -	l E	t GA	u F	
160	1PH4163		407 (16.02)	388 (15.28)	14 (0.55)	18 (0.71)	Pg 36	56 (2.20)	55 (2.17)	M20	110 (4.33)	59 (2.32)	16 (0.63)	
	1PH4167		462 (18.19)											
	1PH4168		507 (19.96)											

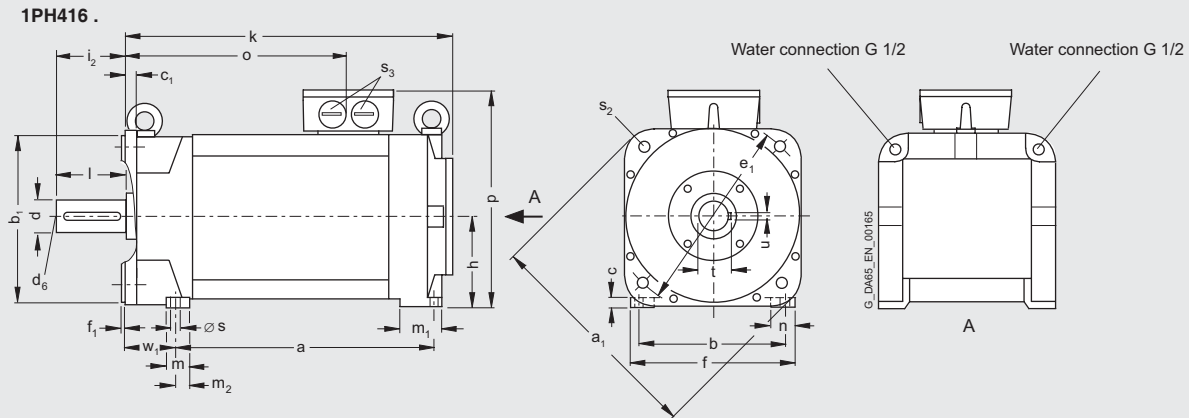

3



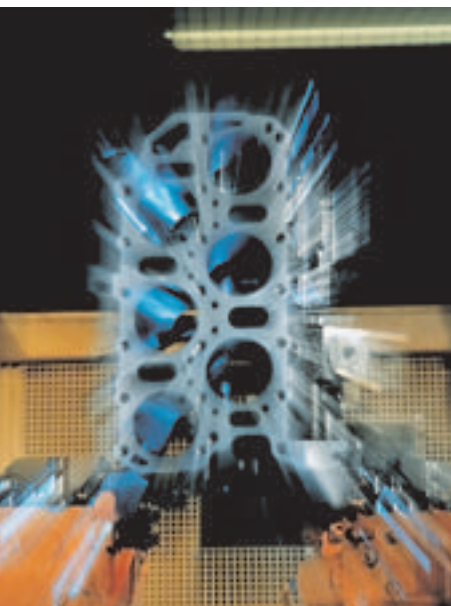

4/2	Built-on optoelectronic rotary encoders
4/2	Introduction
4/3	Function
4/4	<u>Incremental encoders</u>
4/4	Incremental encoder with TTL (RS 422)
4/4	Incremental encoder with sin/cos $1 V_{pp}$
4/4	Incremental encoder with HTL
4/6	<u>Absolute encoders</u>
4/6	Absolute encoder with SSI
4/6	Absolute encoder with EnDat
4/6	Absolute encoder with PROFIBUS DP
4/8	<u>Mounting accessories</u>
4/9	Hollow-shaft measuring system
4/9	SIMAG H2 Hollow-shaft measuring system

Measuring systems SIMODRIVE sensor

Built-on optoelectronic rotary encoders

Introduction

Overview



SIMODRIVE sensors are built-on optoelectronic encoders for the recording of paths, angles of rotation or speeds of machines. They can be used in conjunction with numerical controllers, programmable logic controllers, drives and position displays, e.g. in:

- SINAMICS drive systems
- SIMOTION Motion Control systems
- SINUMERIK CNC controls
- SIMATIC programmable logic controllers
- SIMODRIVE and SIMOVERT MASTERDRIVES drive systems

Application

A distinction is made between incremental and absolute measuring methods:

- In the case of incremental encoders, the machine must travel to a reference point after each power-off, as the position is not usually stored in the controller, and movements of the machine while the power is off are not recorded.
- Absolute encoders, on the other hand, record these movements while the power is off and return to the actual position with power on. Travel to a reference point is not necessary.

Design

All encoders are available in Synchronous flange and flange joint versions. Synchronous flange encoders can be fixed to the machine with 3 clamp straps or mounted with axial screws. The encoder is driven by means of a plug-in coupling or a spring disk coupling. Alternatively, pulleys can also be used.

The encoder supply voltage is 5 V DC or alternatively 10 V to 30 V DC. The 10 V to 30 V DC version supports longer cable lengths. Most control systems apply the supply voltage directly on the measuring circuit connector. With SINAMICS, the power supply for the measuring systems is provided via the SMC Sensor Modules Cabinet-Mounted.

For rotary encoders with cables, the cable length including the connector is 1 m (3.3 ft).

The following bending radii for the cables at the encoder must be complied with:

- One-time bending: ≥ 20 mm (0.8 in)
- Continuous bending: ≥ 75 mm (3 in)

Measuring systems SIMODRIVE sensor

Built-on optoelectronic rotary encoders

Incremental encoders

Absolute encoders

Function



Incremental encoders deliver a defined number of electrical pulses per rotation, which represent the measurement of the travelled distance or angle.

Incremental encoders operate on the principle of optoelectronic scanning of dividing disks using the transmitted light principle. The light source is a light emitting diode (LED). The light-dark modulation generated as the encoder shaft rotates is picked up by photoelectronic elements. With an appropriate arrangement of the line pattern on the dividing disk connected to the shaft and the fixed aperture, the photoelectronic elements provide two trace signals A and B at 90° to one another, as well as a reference signal R. The encoder electronics amplify these signals and convert them into different output levels.

The following output levels are available:

- RS 422 differential signals (TTL)
In the case of RS 422 encoders (TTL), the resolution can be improved by a factor of four by means of edge evaluation.
- 1 V_{pp} analog signals sin/cos
Even better resolution can be achieved for encoders with sinusoidal signals by interpolating them in the higher-level controller.
- HTL (High Voltage Transistor Logic)
Encoders with HTL interfaces are designed for applications with digital inputs with 24 V levels.

Function



Absolute encoders (angle encoders) are designed on the same scanning principle as incremental encoders, but have a greater number of tracks. For example, if there are 13 tracks, then $2^{13} = 8192$ steps are coded in the case of single-turn encoders. The code used is a one-step code (Gray code), which prevents any scanning errors from occurring.

After switching on the machine, the position value is transmitted immediately to the controller. There is no need to travel to a reference point.

Absolute encoders with SSI and EnDat are of advantage in time-critical applications.

In plants with a large number of encoders, PROFIBUS DP is more advantageous due to the reduced wiring overhead. Encoders with PROFIBUS DP are programmable and support isochronous mode with internode communication.

Singleturn encoders divide one rotation (360 degrees mechanical) into a specific number of steps, e.g. 8192. A unique code word is assigned to each position. After 360 degrees the position values are repeated.

Multiturn encoders, in addition to the absolute position within one revolution, also record the number of revolutions. To do this, further code discs which are coupled via gear steps with the encoder shaft are scanned. When evaluating 12 additional tracks, $2^{12} = 4096$ revolutions can be coded.

Measuring systems SIMODRIVE sensor

Built-on optoelectronic rotary encoders

Incremental encoders

Technical specifications

	Incremental encoder with TTL (RS 422)	Incremental encoder with sin/cos 1 V _{pp}	Incremental encoder with HTL	Double-rack incremental encoder with TTL (RS 422)
Operating voltage V _p	5 V DC ±10% or 10 ... 30 V DC	5 V DC ±10%	10 ... 30 V DC	5 V DC ±5%
Limiting frequency, typ.	–	≥ 180 kHz (-3 dB) ≥ 450 kHz (-6 dB)	–	–
Sampling frequency, max.	300 kHz	–	300 kHz	Trace 1: 160 kHz Trace 2: 1 MHz
No-load current consumption, max.	150 mA	150 mA	150 mA	150 mA per trace
Signal level	TTL (RS 422)	sinusoidal 1 V _{pp}	V _H ≥ 21 V at I _H = 20 mA at 24 V V _L ≤ 2.8 V at I _L = 20 mA at 24 V	TTL (RS 422)
Outputs protected against short-circuit to 0 V	Yes	Yes	Yes	Yes
Switching time (10 ... 90%) (with 1 m (3.3 ft) cable and recommended input circuit)	Rise/fall time t _r /t _f ≤ 50 ns	–	Rise/fall time t _r /t _f ≤ 200 ns	Rise/fall time t _r /t _f ≤ 100 ns
Phase angle, signal A to B min. edge spacing at:	90°	90° ±10°el.	90°	90°
• 1 MHz	–	–	–	≥ 0.125 μs (trace 2)
• 300 kHz	≥ 0.45 μs	–	≥ 0.45 μs	–
• 160 kHz	–	–	–	≥ 0.8 μs (trace 1)
Cable length to electronic circuitry ¹⁾ , max.	100 m (328 ft)	150 m (492 ft)	100 m (328 ft)	Up to 500 kHz: 100 m (328 ft) up to 1 MHz: 50 m (164 ft)
LED failure monitoring	High-resistance driver	–	High-resistance driver	–
Resolution, max.	5000 S/R	2500 S/R	2500 S/R	Trace 1: 1024 S/R Trace 2: 9000 S/R
Accuracy (in angular seconds)	±18° mech. × 3600/revolution z	±18° mech. × 3600/revolution z	±18° mech. × 3600/revolution z	Trace 1: ±63 Trace 2: ±12
Electr. speed, permissible	(18 × 10 ⁶ rpm)/revolution	(27 × 10 ⁶ rpm)/revolution (at -6 dB)	(18 × 10 ⁶ rpm)/revolution	Trace 1: 9000 rpm Trace 2: 6500 rpm
Mech. speed, max.	12000 rpm	12000 rpm	12000 rpm	12000 rpm
Friction torque (at 20 °C (68 °F))	≤ 0.01 Nm (0.08 lb _f -in)	≤ 0.01 Nm (0.08 lb _f -in)	≤ 0.01 Nm (0.08 lb _f -in)	≤ 0.01 Nm (0.08 lb _f -in)
Starting torque (at 20 °C (68 °F))	≤ 0.01 Nm (0.08 lb _f -in)	≤ 0.01 Nm (0.08 lb _f -in)	≤ 0.01 Nm (0.08 lb _f -in)	≤ 0.01 Nm (0.08 lb _f -in)
Shaft loading capability				
• n > 6000 rpm				
- Axial	10 N (2.2 lb _f)	10 N (2.2 lb _f)	10 N (2.2 lb _f)	–
- Radial at shaft extension	20 N (4.5 lb _f)	20 N (4.5 lb _f)	20 N (4.5 lb _f)	–
• n ≤ 6000 rpm				
- Axial	40 N (9 lb _f)	40 N (9 lb _f)	40 N (9 lb _f)	10 N (2.2 lb _f)
- Radial at shaft extension	60 N (13.5 lb _f)	60 N (13.5 lb _f)	60 N (13.5 lb _f)	20 N (4.5 lb _f)
Angular acceleration, max.	10 ⁵ rad/s ²	10 ⁵ rad/s ²	10 ⁵ rad/s ²	10 ⁵ rad/s ²
Moment of inertia of rotor	1.45 × 10 ⁻⁶ kgm ² (12.83 × 10 ⁻⁶ lb _f -in-s ²)	1.45 × 10 ⁻⁶ kgm ² (12.83 × 10 ⁻⁶ lb _f -in-s ²)	1.45 × 10 ⁻⁶ kgm ² (12.83 × 10 ⁻⁶ lb _f -in-s ²)	20 × 10 ⁻⁶ kgm ² (177 × 10 ⁻⁶ lb _f -in-s ²)
Vibration (55 ... 2000 Hz) in accordance with IEC 68-2-6	≤ 300 m/s ² (984 ft/s ²)	≤ 300 m/s ² (984 ft/s ²)	≤ 300 m/s ² (984 ft/s ²)	≤ 100 m/s ² (328 ft/s ²)
Shock in accordance with IEC 68-2-27				
• 2 ms	≤ 2000 m/s ² (6563 ft/s ²)	≤ 2000 m/s ² (6563 ft/s ²)	≤ 2000 m/s ² (6563 ft/s ²)	–
• 6 ms	≤ 1000 m/s ² (3281 ft/s ²)	≤ 1000 m/s ² (3281 ft/s ²)	≤ 1000 m/s ² (3281 ft/s ²)	≤ 1000 m/s ² (3281 ft/s ²)
Operating temperature				
• Flange socket or fixed cable				
- At V _p = 5 V ±10%	-40 ... +100 °C (-40 ... +212 °F)	-40 ... +100 °C (-40 ... +212 °F)	-40 ... +100 °C (-40 ... +212 °F)	-10 ... +70 °C (+14 ... +158 °F)
- At V _p = 10 ... 30 V	-40 ... +70 °C (-40 ... +158 °F)	–	–	–
• Flexible cable				
- At V _p = 5 V ±10%	-10 ... +100 °C (+14 ... +212 °F)	-10 ... +100 °C (+14 ... +212 °F)	-10 ... +100 °C (+14 ... +212 °F)	-10 ... +70 °C (+14 ... +158 °F)
- At V _p = 10 ... 30 V	-10 ... +70 °C (+14 ... +158 °F)	–	–	–

Measuring systems SIMODRIVE sensor

Built-on optoelectronic rotary encoders

Incremental encoders

Technical specifications (continued)

	Incremental encoder with TTL (RS 422)	Incremental encoder with sin/cos 1 V _{pp}	Incremental encoder with HTL	Double-track incremental encoder with TTL (RS 422)
Degree of prot. in accordance with EN 60529 (IEC 60529)				
• Without shaft input	IP67	IP67	IP67	IP67
• With shaft input	IP64	IP64	IP64	IP64
EMC	Tested in accordance with the electromagnetic compatibility directive 89/336/EEC and the regulations of the EMC guidelines (applicable basic standards).			
Weight, approx.	0.25 kg (0.5 lb)	0.25 kg (0.5 lb)	0.25 kg (0.5 lb)	0.7 kg (1.5 lb)
CE marking	Yes	Yes	Yes	Yes

¹⁾ With recommended cable and input circuitry of the follow-up electronics, observe max. permissible cable length of module to be evaluated.

Selection and Ordering Data

Description	Order No.	Description	Order No.
Incremental encoder with TTL (RS 422)		Incremental encoder with sin/cos 1 V_{pp}	
<u>Synchronous flange and 5 V DC supply voltage</u>		<u>Synchronous flange and 5 V DC supply voltage</u>	
Connection:		Connection:	
• Axial flange outlet	6FX2001-2G ■■■	• Axial flange outlet	6FX2001-3G ■■■
• Radial flange outlet	6FX2001-2E ■■■	• Radial flange outlet	6FX2001-3E ■■■
• Cable 1 m (3.3 ft) with connector ¹⁾	6FX2001-2C ■■■	• Cable 1 m (3.3 ft) with connector ¹⁾	6FX2001-3C ■■■
<u>Synchronous flange and 10 ... 30 V DC supply voltage</u>		<u>Resolution</u>	↑↑↑
Connection:		1000 S/R	B 0 0
• Axial flange outlet	6FX2001-2H ■■■	1024 S/R	B 0 2
• Radial flange outlet	6FX2001-2F ■■■	2500 S/R	C 5 0
• Cable 1 m (3.3 ft) with connector ¹⁾	6FX2001-2D ■■■		
<u>Supported flange joint and 5 V DC supply voltage</u>		Incremental encoder with HTL	
Connection:		<u>Synchronous flange and 10 ... 30 V DC supply voltage</u>	
• Axial flange outlet	6FX2001-2R ■■■	Connection:	
• Radial flange outlet	6FX2001-2P ■■■	• Axial flange outlet	6FX2001-4H ■■■
• Cable 1 m (3.3 ft) with connector ¹⁾	6FX2001-2M ■■■	• Radial flange outlet	6FX2001-4F ■■■
<u>Supported flange joint and 10 ... 30 V DC supply voltage</u>		• Cable 1 m (3.3 ft) with connector ¹⁾	6FX2001-4D ■■■
Connection:		<u>Supported flange joint and 10 ... 30 V DC supply voltage</u>	
• Axial flange outlet	6FX2001-2S ■■■	Connection:	
• Radial flange outlet	6FX2001-2Q ■■■	• Axial flange outlet	6FX2001-4S ■■■
• Cable 1 m (3.3 ft) with connector ¹⁾	6FX2001-2N ■■■	• Radial flange outlet	6FX2001-4Q ■■■
<u>Resolution</u>	↑↑↑	• Cable 1 m (3.3 ft) with connector ¹⁾	6FX2001-4N ■■■
500 S/R	A 5 0	<u>Resolution</u>	↑↑↑
1000 S/R	B 0 0	100 S/R	A 1 0
1024 S/R	B 0 2	500 S/R	A 5 0
1250 S/R	B 2 5	1000 S/R	B 0 0
1500 S/R	B 5 0	2500 S/R	C 5 0
2000 S/R	C 0 0		
2048 S/R	C 0 4	Double-track incremental encoder with TTL (RS 422)	
2500 S/R	C 5 0	<u>Synchronous flange and 5 V DC supply voltage</u>	
3600 S/R	D 6 0	Connection:	
5000 S/R	F 0 0	• Cable 1 m (3.3 ft) with axial connector	6FX2001-2UK00
		2 types of resolution: 9000/1024 S/R	

¹⁾ Universal integrated cable outlet for axial and radial outlet direction.
S/R = signals/revolution

Measuring systems SIMODRIVE sensor

Built-on optoelectronic rotary encoders

Absolute encoders

Technical specifications

	Absolute encoder with SSI	Absolute encoder with EnDat	Absolute encoder with PROFIBUS DP (EN 50170)
Operating voltage V_p	10 ... 30 V DC	5 V DC $\pm 5\%$	10 ... 30 V DC
Current consumption, approx. • Singleturn • Multiturn	160 mA 200 mA	160 mA 200 mA	300 ... 100 mA (2.5 W) 300 ... 100 mA (2.5 W)
Clock input	Differential cable receiver according to EIA standard RS 485	Differential cable receiver according to EIA standard RS 485	Differential cable receiver according to EIA standard RS 485
Data output	Differential cable driver according to EIA standard RS 485	Differential cable driver according to EIA standard RS 485	Differential cable driver according to EIA standard RS 485
Short-circuit resistance	Yes	Yes	Yes
Data transmission rate	100 kHz to 1 MHz	100 kHz to 2 MHz	12 Mbit/s
LED for bus diagnostics	–	–	Yes (green/red)
Electr. speed permissible • At ± 1 bit-accuracy • At ± 100 bit-accuracy	5000 rpm 10000 rpm	5000 rpm 10000 rpm	5800 rpm –
Mech. speed, max. • Singleturn • Multiturn	12000 rpm 10000 rpm	12000 rpm 10000 rpm	12000 rpm 6000 rpm
Cable length to electronic circuitry ¹⁾ , max.	Up to 1-MHz-cycle: 50 m (164 ft) Up to 300-kHz-cycle: 100 m (328 ft) Up to 100-kHz-cycle: 400 m (1312 ft)	Up to 1-MHz-cycle: 50 m (164 ft) Up to 300-kHz-cycle: 150 m (492 ft)	Up to 12 Mbit/s: 100 m (328 ft) Up to 1.5 Mbit/s: 200 m (656 ft) Up to 93.75 kbit/s: 1200 m (3937 ft)
Number of nodes	–	–	99
Connection	Flange outlet, axial/radial	Flange outlet, axial/radial	Terminal block with address selector switch and bus terminating resistor in removable cover with 3 radial cable glands
Cable diameter	–	–	6.5 to 9 mm (0.25 to 0.35 in) Removal of cover possible without interrupting bus
Resolution • Singleturn • Multiturn	13 bits (8192 steps) 25 bits (8192 \times 4096 steps)	13 bits (8192 steps) 25 bits (8192 \times 4096 steps)	13 bits (8192 steps) 27 bits (8192 \times 16384 steps)
Message frame length • Singleturn • Multiturn	13 bits, without parity 25 bits, without parity	In accordance with EnDat specification In accordance with EnDat specification	– –
Incremental track	–	512 S/R, 1 V_{pp}	–
Code type • Sampling • Data transfer	Gray Gray, tree format	Gray Binary	Gray Binary
Parameterization capability • Resolution per revolution • Total resolution • Preset • Counting direction • Speed signal • Limit switches • Isochronous mode and inter-ode communication acc. to DP V2	– – – Yes – – –	– – – – – – –	Arbitrary 1 ... 8192 Arbitrary 1 ... 16384 Yes Yes Yes Yes, 2 pieces Yes
Online parameterization	–	–	Yes
Network load, approx.	–	–	20 μ s per encoder at 12 Mbit/s
Cycle time	–	–	667 μ s
Accuracy	± 60 angular seconds	± 60 angular seconds (incr. track)	$\pm 1/2$ LSB
EMC	Tested in accordance with EN 50081 and EN 50082	Tested in accordance with EN 50081 and EN 50082	Tested in accordance with EN 50081 and EN 50082
Friction torque (at 20 °C (68 °F))	≤ 0.01 Nm (0.08 lb _f -in)	≤ 0.01 Nm (0.08 lb _f -in)	≤ 0.01 Nm (0.08 lb _f -in)
Starting torque (at 20 °C (68 °F))	≤ 0.01 Nm (0.08 lb _f -in)	≤ 0.01 Nm (0.08 lb _f -in)	≤ 0.01 Nm (0.08 lb _f -in)
Shaft loading capacity • $n > 6000$ rpm - Axial - Radial at shaft extension • $n \leq 6000$ rpm - Axial - Radial at shaft extension	10 N (2.2 lb _f) 20 N (4.5 lb _f) 40 N (9 lb _f) 60 N (13.5 lb _f)	10 N (2.2 lb _f) 20 N (4.5 lb _f) 40 N (9 lb _f) 60 N (13.5 lb _f)	10 N (2.2 lb _f) 20 N (4.5 lb _f) 40 N (9 lb _f) 110 N (24.7 lb _f)

Technical specifications (continued)

	Absolute encoder with SSI	Absolute encoder with EnDat	Absolute encoder with PROFIBUS DP (EN 50170)
Angular acceleration, max.	10 ⁵ rad/s ²	10 ⁵ rad/s ²	10 ⁵ rad/s ²
Moment of inertia of rotor	1.45 × 10 ⁻⁶ kgm ² (12.83 × 10 ⁻⁶ lb _F -in-s ²)	1.45 × 10 ⁻⁶ kgm ² (12.83 × 10 ⁻⁶ lb _F -in-s ²)	1.45 × 10 ⁻⁶ kgm ² (12.83 × 10 ⁻⁶ lb _F -in-s ²)
Vibration (55 ... 2000 Hz) in accordance with IEC 68-2-6	≤ 300 m/s ² (984 ft/s ²)	≤ 300 m/s ² (984 ft/s ²)	≤ 100 m/s ² (328 ft/s ²)
Shock in accordance with IEC 68-2-27			
• 2 ms	≤ 2000 m/s ² (6563 ft/s ²)	≤ 2000 m/s ² (6563 ft/s ²)	≤ 2000 m/s ² (6563 ft/s ²)
• 6 ms	≤ 1000 m/s ² (3281 ft/s ²)	≤ 1000 m/s ² (3281 ft/s ²)	≤ 1000 m/s ² (3281 ft/s ²)
Operating temperature	-40 °C ... +85 °C (-40 °F ... +185 °F)	-40 °C ... +100 °C (-40 °F ... +212 °F)	-40 °C ... +85 °C (-40 °F ... +185 °F)
Degree of protection in accordance with EN 60529 (IEC 60529)			
• Without shaft input	IP67	IP67	IP67
• With shaft input	IP64	IP64	IP64
Weight, approx.			
• Singleturn	0.35 kg (0.8 lb)	0.35 kg (0.8 lb)	0.5 kg (1 lb)
• Multiturn	0.35 kg (0.8 lb)	0.35 kg (0.8 lb)	0.7 kg (1.5 lb)
CE marking	Yes	Yes	Yes
PROFIBUS certificate	–	–	Yes
Supported profiles	–	–	Class 1, Class 2

1) Observe the maximum permissible cable length of the connected module.

Selection and Ordering Data

Description	Order No.	Description	Order No.
Absolute encoder with SSI		Absolute encoder with PROFIBUS DP (EN 50170)	
<u>Synchronous flange and 10 ... 30 V DC supply voltage</u>		<u>10 ... 30 V DC supply voltage</u>	
Connection:		Radial connection	
• axial flange outlet	6FX2001-5HS ■ ■	• Synchronous flange Solid shaft	6FX2001-5FP ■ ■
• radial flange outlet	6FX2001-5FS ■ ■	• Supported flange joint Solid shaft	6FX2001-5QP ■ ■
<u>Supported flange joint and 10 ... 30 V DC supply voltage</u>		• Torque counteracting support Hollow shaft 8 mm/10 mm/12 mm/15 mm (0.31 in/0.39 in/0.47 in/0.59 in)	6FX2001-5WP ■ ■
Connection:		<u>Resolution</u>	
• axial flange outlet	6FX2001-5SS ■ ■	• Singleturn 8192 steps/revolution (13-bit)	↑ ↑ 1 2
• radial flange outlet	6FX2001-5QS ■ ■	• Multiturn 8192 steps/revolution, 4096 revolutions (25-bit)	2 4
<u>Resolution</u>		User Manual for commissioning and parameterization of PROFIBUS encoders Languages: English/German	6SN1197-0AB10-0YP4
• Singleturn 8192 steps/revolution (13-bit)	↑ ↑ 1 2		
• Multiturn 8192 steps/revolution, 4096 revolutions (25-bit)	2 4		
Absolute encoder with EnDat		More information	
<u>Synchronous flange and 5 V DC supply voltage</u>		Description	Order No.
Connection:		Decentralization with PROFIBUS DP	ISBN3-89578-074-X
• axial flange outlet	6FX2001-5HE ■ ■		
• radial flange outlet	6FX2001-5FE ■ ■		
<u>Supported flange joint and 5 V DC supply voltage</u>			
Connection:			
• axial flange outlet	6FX2001-5SE ■ ■		
• radial flange outlet	6FX2001-5QE ■ ■		
<u>Resolution</u>			
• Singleturn 8192 steps/revolution (13-bit)	↑ ↑ 1 3		
• Multiturn 8192 steps/revolution, 4096 revolutions (25-bit)	2 5		

Measuring systems SIMODRIVE sensor

Built-on optoelectronic rotary encoders

Mounting accessories

Overview



Clamp straps/couplings

Clamp straps and couplings are available as mounting accessories for the rotary encoders. The clamp straps are used to fix the encoders with a synchronous flange.

Mating connector

A mating connector is available for the encoder with flange outlet or with cable and encoder connector for cable diameters 5.5 mm (0.22 in) to 12 mm (0.47 in). Connectors with 12 contact pins are suitable for all incremental encoders, as well as for absolute encoders with SSI. Connectors with 17 contact pins are suitable for encoders with EnDat.

Replacement connector

A replacement connector is available for encoders with cable.

Technical specifications

	Spring disk coupling	Plug-in coupling
Transmission torque, max.	0.8 Nm (7 lb _f -in)	0.7 Nm (6.2 lb _f -in)
Shaft diameter	6 mm (0.24 in) on both sides or $d_1 = 6 \text{ mm (0.24 in)}$, $d_2 = 5 \text{ mm (0.20 in)}$	6 mm (0.24 in) on both sides or 10 mm (0.39 in) on both sides
Center offset of shafts, max.	0.4 mm (0.02 in)	0.5 mm (0.02 in)
Axial offset	±0.4 mm (0.02 in)	±0.5 mm (0.02 in)
Angular displacement of shafts, max.	3°	1°
Torsional rigidity	150 Nm/rad (1327.5 lb _f -in/rad)	31 Nm/rad (274.3 lb _f -in/rad)
Lateral spring stiffness	6 N/mm (1.34 lb _f -in)	10 N/mm (2.25 lb _f -in)
Moment of inertia	19 gcm ² (168 × 10 ⁻⁷ lb _f -in-s ²)	20 gcm ² (177 × 10 ⁻⁷ lb _f -in-s ²)
Speed, max.	12000 rpm	12000 rpm
Operating temperature	-40 °C... +150 °C (-40 °F... +302 °F)	-40 °C... +80 °C (-40 °F... +176 °F)
Weight, approx.	16 g (0.03 lb)	20 g (0.04 lb)

Selection and Ordering Data

Designation	Order No.
Clamp strap for double-track encoder and encoder with Synchronous flange (3 units are required)	6FX2001-7KP01
Spring disk coupling Shaft diameter:	
• 6 mm (0.24 in)/6 mm (0.24 in)	6FX2001-7KF10
• 6 mm (0.24 in)/5 mm (0.19 in)	6FX2001-7KF06
Plug-in coupling Shaft diameter:	
• 6 mm (0.24 in)/6 mm (0.24 in)	6FX2001-7KS06
• 10 mm (0.39 in)/10 mm (0.39 in)	6FX2001-7KS10
Mating connector for flange outlet or encoder plug with cap nut (1 piece) Crimp version, socket contacts for cable diameters 5.5 ... 12 mm (0.22 ... 0.47 in)	
• 12-pin insulator with 12 socket contacts (1 piece) for incremental encoder with TTL, sin/cos 1 V _{pp} , HTL for absolute encoder with SSI	6FX2003-0SU12
• 17-pin insulator with 17 socket contacts (1 piece) for absolute encoder with EnDat	6FX2003-0SU17
Replacement connectors with external thread for encoders (1 piece)	6FX2003-0SA12
• 12-pin insulator with 12 contact pins (1 piece) for incremental encoders with RS 422, sin/cos 1 V _{pp} , HTL for absolute encoder with SSI	

Measuring systems SIMODRIVE sensor

Hollow-shaft measuring system

SIMAG H2 hollow-shaft measuring system

Application

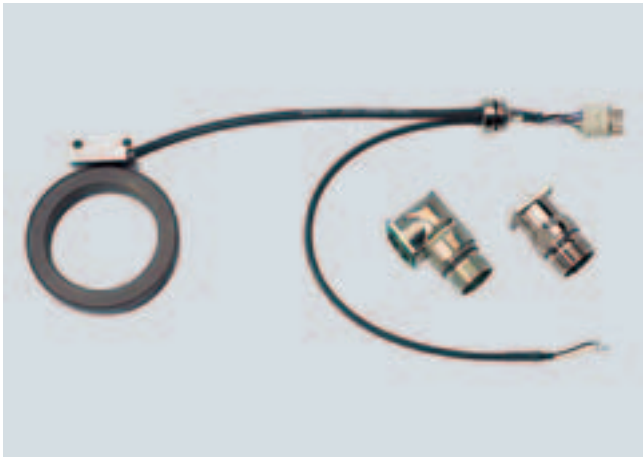

SIMAG H2 is an incremental system for measuring angles of rotation and rotational speeds. Applications include hollow-shaft applications with direct drives, as well as applications as an autonomous spindle encoder.

The electrical signals and the flange outlet are compatible with existing motor measuring systems. SIMAG H2 can be operated with all commonly available controls as a motor measuring system or as a direct measuring system.

Design

The SIMAG H2 measuring system consists of three components:

- Measuring wheel
- Scanning head with connecting lead
- Connection kit

The magnetic division on the measuring wheel is used as a unit of measurement. Different internal diameters are available for each outer diameter, whereby the internal diameter can be reworked. The measuring wheel is attached with the shaft nut; alternatives are screw fitting to a shaft shoulder (not possible with all measuring wheel variants) or shrink fitting.

The non-contact scanning head scans the incremental and reference tracks at the measuring wheel and amplifies the signals.

It is connected via a lead attached to the scanning head. The end of the lead is pre-assembled with contacts and an insulation insert. For assembly, the insulation insert can be fixed into a straight or angular flange outlet. For confined spaces, the encoder can also be supplied with open core ends.

Technical specifications

	SIMAG H2 hollow-shaft measuring system
Output signals	2 voltage signals 1 V _{pp} in quadrature; 1 reference signal per encoder rotation
Operating voltage	5 V DC ±5%
Power consumption, typical	30 mA
Resolution (at outer diameter D_a)	192 S/R (D_a 60.72 mm/2.39 in) 256 S/R (D_a 81.14 mm/3.19 in) 400 S/R (D_a 126.92 mm/5 in) 480 S/R (D_a 152.39 mm/6 in) 800 S/R (D_a 254.25 mm/10 in)
Indexing accuracy of measuring wheel	
• At a resolution of 192 S/R	±96 angular seconds
• At a resolution of 256 S/R	±72 angular seconds
• At a resolution of 400 S/R	±46 angular seconds
• At a resolution of 480 S/R	±38 angular seconds
• At a resolution of 800 S/R	±23 angular seconds
Limiting speed	
• At a resolution of 192 S/R	≤ 33,000 rpm
• At a resolution of 256 S/R	≤ 25,000 rpm
• At a resolution of 400 S/R	≤ 16,000 rpm
• At a resolution of 480 S/R	≤ 13,000 rpm
• At a resolution of 800 S/R	≤ 8,000 rpm
Rated distance between measuring wheel and scanning head	200 μm
Operating temperature range	-20 °C ... +120 °C (-4 °F ... +248 °F)
Shock resistance (11 ms)	1000 m/s ² (3281 ft/s ²)
Vibration (50 ... 2000 Hz)	200 m/s ² (656 ft/s ²)
Degree of protection in accordance with EN 60529 (IEC 60529)	IP67 when installed
Bending radius of the cable module lines	
• One-time bending	≥ 25 mm (0.98 in)
• Multiple bending	≥ 60 mm (2.36 in)
Length of cable to converter, max.	50 m (164 ft)
Dimensions, approx. Scanning head (mounted)	
• Width	36 mm (1.42 in)
• Height	18 mm (0.71 in)
• Depth	15 mm (0.59 in)

Measuring systems SIMODRIVE sensor

Hollow-shaft measuring system

SIMAG H2 hollow-shaft measuring system

Technical specifications (continued)

Measuring wheels

Measuring wheel outer diameter $D_a = 60.72$ mm (2.39 in)		
Internal diameter ¹⁾	mm (in)	40 ^{H6} (1.57 ^{H6})
Thickness	mm (in)	15 (0.59)
Number of signals/revolution		192
Moment of inertia, approx.	kgm ² (lb _F -in-s ²)	1.0 × 10 ⁻⁴ (8.85 × 10 ⁻⁴)
Weight, approx.	kg (lb)	0.20 (0.44)

Measuring wheel outer diameter $D_a = 81.14$ mm (3.19 in)				
Internal diameter ¹⁾	mm (in)	45 ^{H6} (1.76 ^{H6})	60 ^{H6} (2.36 ^{H6})	65 ^{H6} (2.56 ^{H6})
Thickness	mm (in)	15 (0.59)	15 (0.59)	15 (0.59)
Number of signals/revolution		256	256	256
Moment of inertia, approx.	kgm ² (lb _F -in-s ²)	3.8 × 10 ⁻⁴ (33.63 × 10 ⁻⁴)	2.8 × 10 ⁻⁴ (24.78 × 10 ⁻⁴)	2.2 × 10 ⁻⁴ (19.47 × 10 ⁻⁴)
Weight, approx.	kg (lb)	0.35 (0.77)	0.25 (0.55)	0.20 (0.44)

Measuring wheel outer diameter $D_a = 126.92$ mm (5 in)				
Internal diameter ¹⁾	mm (in)	65 ^{H6} (2.56 ^{H6})	85 ^{H6} (3.35 ^{H6})	100 ^{H6} (3.94 ^{H6})
Thickness	mm (in)	15 (0.59)	15 (0.59)	15 (0.59)
Number of signals/revolution		400	400	400
Moment of inertia, approx.	kgm ² (lb _F -in-s ²)	25 × 10 ⁻⁴ (222.25 × 10 ⁻⁴)	21 × 10 ⁻⁴ (185.85 × 10 ⁻⁴)	16 × 10 ⁻⁴ (141.60 × 10 ⁻⁴)
Weight, approx.	kg (lb)	1.0 (2.20)	0.75 (1.65)	0.5 (1.10)

Measuring wheel outer diameter $D_a = 152.39$ mm (6 in)			
Internal diameter ¹⁾	mm (in)	80 ^{H6} (3.15 ^{H6})	110 ^{H6} (4.33 ^{H6})
Thickness	mm (in)	15 (0.59)	15 (0.59)
Number of signals/revolution		480	480
Moment of inertia, approx.	kgm ² (lb _F -in-s ²)	54 × 10 ⁻⁴ (477.89 × 10 ⁻⁴)	42 × 10 ⁻⁴ (371.69 × 10 ⁻⁴)
Weight, approx.	kg (lb)	1.5 (3.31)	1.0 (2.20)

Measuring wheel outer diameter $D_a = 254.25$ mm (10 in)		
Internal diameter ¹⁾	mm (in)	150 ^{H6} (5.91 ^{H6})
Thickness	mm (in)	15 (0.59)
Number of signals/revolution		800
Moment of inertia, approx.	kgm ² (lb _F -in-s ²)	420 × 10 ⁻⁴ (3717.31 × 10 ⁻⁴)
Weight, approx.	kg (lb)	3.9 (8.6)

Selection and Ordering Data

Description	Order No.
Scanning head, incremental 1 mm (0.04 inch) pole pitch, 1 V _{PP}	
• With plug insert, with 0.2 m (7.8 in) signal cable and 0.3 m (11.8 in) temperature cable (2-core)	6FX2001-6AA12-1CA0
• With plug insert, with 0.5 m (19.6 in) signal cable and 0.3 m (11.8 in) temperature cable (2-core)	6FX2001-6AA12-1FA0
• With plug insert, with 2.0 m (6.6 ft) signal cable and 0.3 m (11.8 in) temperature cable (2-core)	6FX2001-6AA12-3AA0
• Open core ends, with 1.0 (3.3 ft) signal cable	6FX2001-6AA12-2AA5
Measuring wheel = D_a 60.72 mm (2.39 in)	
• Internal diameter 40 ^{H6} mm (1.57 ^{H6} in)	6FX2001-6RB12-3EA0
Measuring wheel = D_a 81.14 mm (3.19 in)	
• Internal diameter 45 ^{H6} mm (1.77 ^{H6} in)	6FX2001-6RB12-4EF0
• Internal diameter 60 ^{H6} mm (2.36 ^{H6} in)	6FX2001-6RB12-4GA0
• Internal diameter 65 ^{H6} mm (2.56 ^{H6} in)	6FX2001-6RB12-4GF0
Measuring wheel = D_a 126.92 mm (5 in)	
• Internal diameter 65 ^{H6} mm (2.56 ^{H6} in)	6FX2001-6RB12-5GF0
• Internal diameter 85 ^{H6} mm (3.35 ^{H6} in)	6FX2001-6RB12-5JF0
• Internal diameter 100 ^{H6} mm (3.94 ^{H6} in)	6FX2001-6RB12-5LA0
Measuring wheel = D_a 152.39 mm (6 in)	
• Internal diameter 80 ^{H6} mm (3.15 ^{H6} in)	6FX2001-6RB12-6JA0
• Internal diameter 110 ^{H6} mm (4.33 ^{H6} in)	6FX2001-6RB12-6MA0
Measuring wheel = D_a 254.25 mm (10 in)	
• Internal diameter 150 ^{H6} mm (5.91 ^{H6} in)	6FX2001-6RB12-7SA0
Connection kit for insulation insert	
• Straight flange outlet	6FX2001-6FA12-0GA0
• Angular flange outlet	6FX2001-6FA12-0WA0
Extraction tool for insulation insert of straight or angular flange outlet	6FX2001-6FK12-0AA0

¹⁾ The measuring wheels can be re-worked (by increasing the inner diameter or by drilling holes/tapping threads); see Configuring/Installation Guide.

MOTION-CONNECT connection system

5

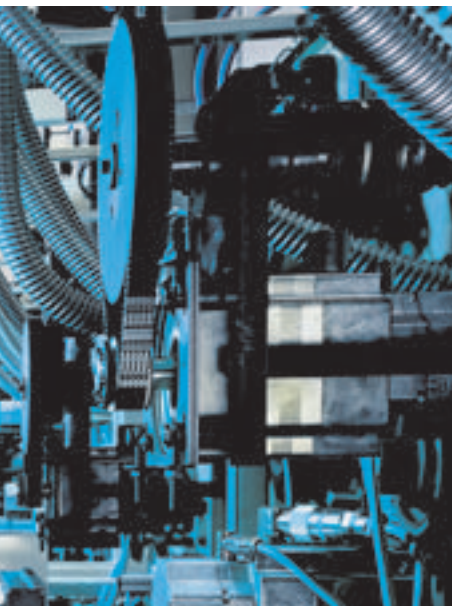

5/2

General

5/5

Power cables

5/6

Power cables
without brake cores

5/7

Power cables
with brake cores

5/8

Extensions

5/10

Accessories for power cables

5/10

Flange and HF clamp

5/10

Power connector

5/11

Signal cables

5/19

Accessories for signal cables

5/19

Flange and HF clamp

5/19

DRIVE-CLiQ cabinet conduit
and coupler

5/20

Length codes



MOTION-CONNECT connection system

General

Overview

MOTION-CONNECT cables can be used in a wide range of production machines and machine tools.

These power and signal cables can be ordered by the meter and as cable assemblies.

MOTION-CONNECT comprises of the following cable types:

- **MOTION-CONNECT 500** is the solution for mainly fixed routing.
- **MOTION-CONNECT 500 PLUS** is suitable for drag chains, can withstand mineral-based oils (except biological oils and cutting oils) and is therefore especially well suited for wood-working machines, printing machines and simple tooling machines. The current MOTION-CONNECT 500 signal cables already full-fill the requirements for MOTION-CONNECT 500 PLUS, such that no new type is required for signal cables.
- **MOTION-CONNECT 700** is ideal supplement for linear motors and machines with stringent mechanical requirements.
- **MOTION-CONNECT 800** meets all requirements for use in cable carriers for machine tools and production machines.

Benefits

The use of pre-assembled MOTION-CONNECT cables will ensure high quality and system-tested, problem-free operation. The cables can be supplied in exact meter lengths. Intermediate lengths are also available in 0.1 m increments.

Power and signal cables can be specified by length or configured as required.

Application

Degree of protection of pre-assembled power and signal cables and their extensions is IP67 when closed and connected.

When specifying cable lengths for the systems and applications in this catalog, the maximum permissible cable lengths indicated in the technical data must not be exceeded. Malfunctions can occur if longer cables are used.

Siemens AG assumes no liability for correct transmission of signals or power in this case.

When the power and/or signal cables include more than one additional intermediate connection, the maximum permissible cable length is reduced by 2 m for each interruption point.

The cables are not suitable for outdoor use.



Technical specifications

DRIVE-CLiQ signal cables	DRIVE-CLiQ	DRIVE-CLiQ MOTION-CONNECT 500	DRIVE-CLiQ MOTION-CONNECT 800
Type	6FX2...-1DC...-....	6FX5...-DC...-....	6FX8...-DC...-....
Approvals			
• VDE ¹⁾	Yes	Yes	Yes
• cUL or UL/CSA	UL STYLE 2502/CSA-N.210.2-M90	UL STYLE 2502/CSA-N.210.2-M90	UL STYLE 2502/CSA-N.210.2-M90
• UL-CSA File No. ²⁾	Yes	Yes	Yes
Electrical data in accordance with DIN VDE 0472			
Rated voltage	30 V	30 V	30 V
Test voltage (rms)	500 V	500 V	500 V
Operating temperature on the surface			
• Fixed installation	-20 ... +80 °C (-4 ... +176 °F)	-20 ... +80 °C (-4 ... +176 °F)	-50 ...+80 °C (-58 ... +176 °F)
• Flexible installation	–	0 ...+60 °C (+32 ... +140 °F)	-20 ...+60 °C (-4 ... +140 °F)
Mechanical data			
Tensile stress, max.			
• Fixed installation	45 N/mm ² (6526 lb _f /in ²)	50 N/mm ² (7251 lb _f /in ²)	50 N/mm ² (7251 lb _f /in ²)
• Flexible installation	–	20 N/mm ² (2900 lb _f /in ²)	20 N/mm ² (2900 lb _f /in ²)
Smallest bending radius			
• Fixed installation	50 mm (1.97 in)	35 mm (1.38 in)	60 mm (2.36 in)
• Flexible installation	–	125 mm (4.92 in)	100 mm (3.94 in)
Torsional stress	–	Absolute 30°/m	Absolute 30°/m
Bending	–	100000	10 million
Traversing speed	–	30 m/min (98.4 ft/min)	180 m/min (590.58 ft/min)
Acceleration	–	2 m/s ² (6.56 ft/s ²)	5 m/s ² (16.41 ft/s ²) (5 m (16.41 ft)); 10 m/s ² (32.81 ft/s ²) (2.5 m (8.2 ft))
Chemical data			
Insulation material	CFC/silicon-free	CFC/silicon-free	CFC/halogen/silicon-free DIN 472815/IEC 60754-1
Oil resistance	EN 60811-1-1/-2-1	EN 60811-1-1/-2-1	VDE 0472, Part 803 Test mode B
Outer shield	PVC Gray RAL 7032	PVC DESINA color green RAL 6018	PUR, DIN VDE 0282, Part 10 DESINA color green RAL 6018
Flame-retardant	IEC 60332.1	IEC 60332.1	IEC 60332.1

Technical specifications (continued)

Power/signal cables	MOTION-CONNECT 500 ³⁾	MOTION-CONNECT 500 PLUS	MOTION-CONNECT 700	MOTION-CONNECT 800
Type	6FX500-.....	6FX51-.....	6FX700-.....	6FX800-.....
Approvals				
• VDE ¹⁾	Yes	Yes	Yes	Yes
• cUL or UL/CSA	UL758-CSA-C22.2-N.210.2-M90	UL758-CSA-C22.2 N210.2-M90	UL758-CSA-C22.2-N.210.2-M90	UL758-CSA-C22.2-N.210.2-M90
• UL-CSA File No. ²⁾	Yes	Yes	Yes	Yes
Electrical data in accordance with DIN VDE 0472				
Rated voltage				
• Power cables V_0/V				
- Power conductors	600 V/1000 V	600 V/1000 V	600 V/1000 V	600 V/1000 V
- Signal conductors	24 V (VDE) 1000 V (UL/CSA)	24 V (VDE) 1000 V (UL/CSA)	24 V (VDE) 1000 V (UL/CSA)	24 V (VDE) 1000 V (UL/CSA)
• Signal cables	30 V	–	30 V	30 V
Test voltage (rms)				
• Power cables				
- Power conductors	4 kV	4 kV	4 kV	4 kV
- Signal conductors	2 kV	2 kV	2 kV	2 kV
• Signal cables	500 V	–	500 V	500 V
Operating temperature on the surface				
• Fixed installation	-20 ...+80 °C (-4 ... +176 °F)	-20 ...+80 °C (-4 ... +176 °F)	-20 ...+80 °C (-4 ... +176 °F)	-50 ...+80 °C (-58 ... +176 °F)
• Flexible installation	0 ...+60 °C (+32 ... +140 °F)	0 ...+60 °C (+32 ... +140 °F)	-20 ...+60 °C (-4 ... +140 °F)	-20 ...+60 °C (-4 ... +140 °F)
Mechanical data				
Tensile stress, max.				
• Fixed installation	50 N/mm ² (7251 lb _f /in ²)	50 N/mm ² (7251 lb _f /in ²)	50 N/mm ² (7251 lb _f /in ²)	50 N/mm ² (7251 lb _f /in ²)
• Flexible installation	20 N/mm ² (2900 lb _f /in ²)	20 N/mm ² (2900 lb _f /in ²)	20 N/mm ² (2900 lb _f /in ²)	20 N/mm ² (2900 lb _f /in ²)
Smallest bending radius				
• Power cables				
- Fixed installation	$5 \times D_{\max}$	$5 \times D_{\max}$	$4 \times D_{\max}$	$6 \times D_{\max}$
- Flexible installation	See power cables	See power cables	See power cables	See power cables
• Signal cables				
- Fixed installation	60 mm (2.36 in)	–	60 mm (2.36 in)	60 mm (2.36 in)
- Flexible installation	100 mm (3.94 in)	–	95 mm (3.74 in)	100 mm (3.94 in)
Torsional stress	Absolute 30°/m	Absolute 30°/m	Absolute 30°/m	Absolute 30°/m
Bending				
• Power cables				
- 1.5 ... 6 mm ²	100000	2 million	10 million	10 million
- 10 ... 185 mm ²	100000	–	10 million	3 million
• Signal cables	2 million	–	10 million	10 million
Traversing speed				
• Power cables				
- 1.5 ... 6 mm ²	30 m/min (98.4 ft/min)	180 m/min (590.6 ft/min)	200 m/min (656.2 ft/min)	180 m/min (590.6 ft/min)
- 10 ... 185 mm ²	30 m/min (98.4 ft/min)	–	200 m/min (656.2 ft/min)	100 m/min (590.6 ft/min)
• Signal cables	180 m/min (590.6 ft/min)	–	200 m/min (656.2 ft/min)	180 m/min (590.6 ft/min)
Acceleration				
• Power cables	2 m/s ² (6.56 ft/s ²)	5 m/s ² (16.41 ft/s ²)	30 m/s ² (98.43 ft/s ²)	5 m/s ² (16.41 ft/s ²) (5 m (16.41 ft)); 10 m/s ² (32.81 ft/s ²) (2.5 m (8.2 ft))
• Signal cables	5 m/s ² (16.41 ft/s ²)	–	30 m/s ² (98.43 ft/s ²)	5 m/s ² (16.41 ft/s ²) (5 m (16.41 ft)); 10 m/s ² (32.81 ft/s ²) (2.5 m (8.2 ft))
Chemical data				
Insulation material	CFC/silicon-free	CFC/silicon-free	CFC/halogen/silicon-free DIN 472815/IEC 60754-1	CFC/halogen/silicon-free DIN 472815/IEC 60754-1
Oil resistance	VDE 0472, Part 803 Test mode B (mineral oil only)	EN 60811-1-1/-2-1 (mineral oil only)	VDE 0472, Part 803 Test mode B	VDE 0472, Part 803 Test mode B
Outer shield	PVC	PVC	PUR, DIN VDE 0282, Part 10	PUR, DIN VDE 0282, Part 10
• Power cables	DESINA color orange RAL 2003	DESINA color orange RAL 2003	DESINA color orange RAL 2003	DESINA color orange RAL 2003
• Signal cables	DESINA color green RAL 6018	–	DESINA color green RAL 6018	DESINA color green RAL 6018
Flame-retardant	IEC 60332.1	IEC 60332.1	IEC 60332.1	IEC 60332.1

¹⁾ The respective registration number is printed on the cable shield (only valid for power cables).

²⁾ The File Number is printed on the cable shield.

³⁾ MOTION-CONNECT 500 cables can also be used for motors with a rated voltage of 690 V.

MOTION-CONNECT connection system

General

Function

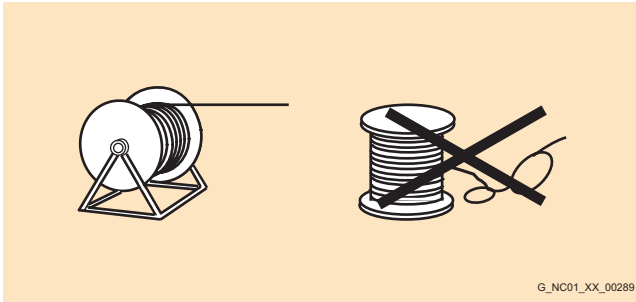

G_NC01_XX_00289

The cables must be removed from the drum without twisting, i.e., the cables must be unwound and must never be lifted over the drum flange in loops.

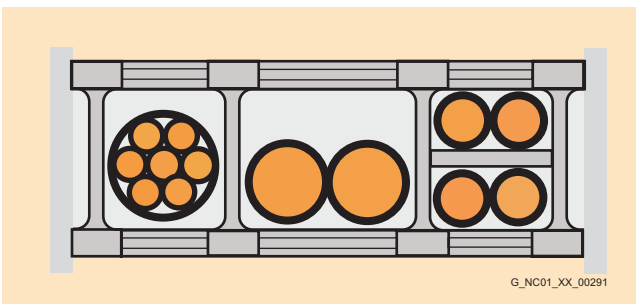

G_NC01_XX_00291

To maximize the service life of the cable carrier and cables, cables in the carrier made from different materials must be installed in the cable carrier with spacers. The spacers must be filled evenly to ensure that the position of the cables does not change during operation. The cables should be distributed as symmetrically as possible according to their weights and dimensions. Cables with very different outer diameters should be separated by spacers.

When inserting pre-assembled cables into the cable carrier, do **not** pull at the connector, as this may damage the strain relief or cable clamping.

The cables must not be fixed in the cable carrier. They must be freely movable.

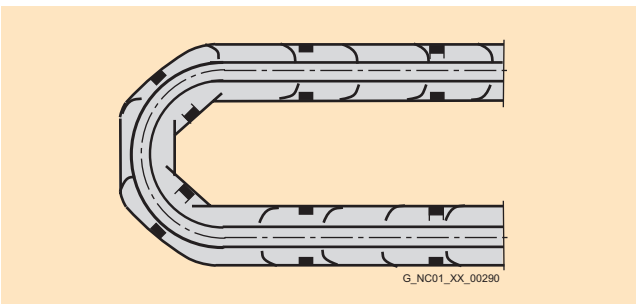

G_NC01_XX_00290

The cables must be able to move freely, particularly in the bending radii of the carrier. The specified minimum bending radii must be adhered to.

The cable mountings must be attached at both ends at an appropriate distance away from the end points of the moving parts in a "dead" zone.

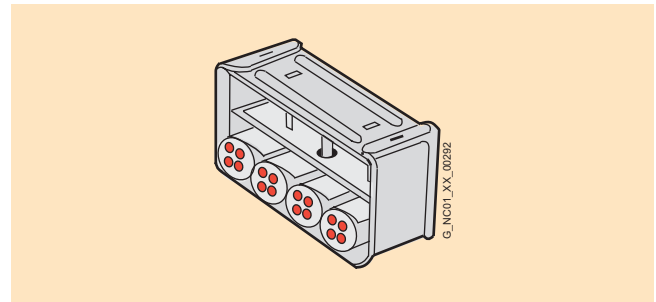

G_NC01_XX_00292

MOTION-CONNECT cables are tested in a cable carrier. A cable strain relief is attached to the moving ends of the cable carrier. Strain relief is applied over a wide area of the sheath surface without crimping the cable.

When routing the cables, always observe the installation instructions of the cable carrier manufacturer depending on the design of the plant.

Notes:

If, for example, pre-assembled cables are installed in a cable carrier in such a way that the connector would inhibit assembly, pre-assembled cables without assembled connectors can also be supplied (signal and power cables). In this case, the contacts of the cables are crimped and the connector housing is supplied separately. After routing the cables, the customer assembles the connector housing.

Cables must always be installed in accordance with the instructions supplied by the cable carrier manufacturer.

MOTION-CONNECT cables are approved for a maximum horizontal travel distance of 5 m (16.4 ft).

In case of vibration load and with horizontal or vertical cable entries, we recommend that the cable is additionally fixed if part of the cable is hanging loose or is not routed between the cable strain relief on the cable carrier and the terminal at the motor. To prevent machine vibrations being transmitted to the connectors, the cable should be fixed at the moving part where the motor is mounted.

Representation in the overview of connections

Symbol	Explanation
	Connector with pin contact
	Female connector
	Open core ends

Overview



Motor module connector with circular plug



Motor module connector with open core ends



Ring terminal ends with circular plug



Power module connecting cable with circular plug

MOTION-CONNECT power cables are used to connect synchronous and asynchronous motors with Motor Modules or Power Modules.

The pre-assembled MOTION-CONNECT power cables offer excellent quality and ensure safety and fault-free operation.

Depending on the design, the MOTION-CONNECT power cables have pre-assembled connectors at either one or both ends.

Note : All 6FX.002-5....-..... power cables are available with crimped contacts and with the connector housing supplied separately.

- Power cables with separately supplied **module-end** connector housing: 6FX.012-5....-..... (1 in 6th position)

Technical specifications

Current carrying capacity

The current-carrying capacity I_z of PVC-insulated cables complies with IEC 60204-1 for routing type C under continuous operating conditions and is specified in the table with reference to an ambient air temperature of 40 °C (104 °F). For other ambient temperatures, the values must be corrected with the "derating factors" in the table. PUR cables are also subject to this standard.

Cross section mm ²	Current carrying capacity I_z in A in accordance with IEC 60204-1 dated 1997 + Corrigendum 1998 for type of routing (see standard, Table C1.2)			
	B1	B2	C	E
0.75	7.6	–	–	–
1.0	10.4	9.6	11.7	11.5
1.5	13.5	12.2	15.2	16.1
2.5	18.3	16.5	21	22
4	25	23	28	30
6	32	29	36	37
10	44	40	50	52
16	60	53	66	70
25	77	67	84	88
35	97	83	104	114
50	–	–	123	123
70	–	–	155	155
95	–	–	192	192
120	–	–	221	221
150	–	–	234	262
185	–	–	267	300
Electronics (pairs)				
0.2	–	–	4.0	4.0
0.3	–	–	5.0	5.0
0.5	–	–	7.1	7.1
0.75	–	–	9.1	9.1

Derating factors

Ambient air temperature °C (°F)	Derating factor to IEC 60364-5-523, Table 52-D1
30 (86)	1.15
35 (95)	1.08
40 (104)	1.00
45 (113)	0.91
50 (122)	0.82
55 (131)	0.71
60 (140)	0.58

Power cables

Selection and ordering data

MOTION-CONNECT power cables *without* brake cores for Motor Modules

Connection method, at Motor Module end ¹⁾	Number of cores x cross section mm ²	Connector size, motor end	Pre-assembled cable for 1FT/1FK motors	D_{max}		Cable (sold by meter) ²⁾ for motors with terminal box	Weight (without connector)		Smallest perm. bending radius ³⁾	
			Order No.	6FX5 mm (in)	6FX8 mm (in)	Order No.	6FX5 kg/m (lb/ft)	6FX8 kg/m (lb/ft)	6FX5 mm (in)	6FX8 mm (in)
Connector ⁵⁾	4x1.5	1	6FX 002-5CS01-....	8.4 (0.33)	10.4 (0.41)	6FX 008-1BB11-....	0.12 (0.3)	0.16 (0.4)	155 (6.1)	100 (3.94)
		1.5	6FX 002-5CS21-....							
		o.c. ⁴⁾	6FX5002-5CS02-....							
	4x2.5	1	6FX 002-5CS11-....	10 (0.39)	12.1 (0.48)	6FX 008-1BB21-....	0.21 (0.5)	0.23 (0.5)	180 (7.09)	120 (4.72)
		1.5	6FX 002-5CS31-....							
		o.c. ⁴⁾	6FX5002-5CS12-....							
	4x4	1.5	6FX 002-5CS41-....	11.4 (0.45)	13.2 (0.52)	6FX 008-1BB31-....	0.27 (0.6)	0.31 (0.7)	210 (8.27)	130 (5.12)
		o.c. ⁴⁾	6FX5002-5CS42-....							
	4x6	1.5	6FX 002-5CS51-....	13.6 (0.54)	16 (0.63)	6FX 008-1BB41-....	0.37 (0.8)	0.42 (0.9)	245 (9.65)	170 (6.69)
		o.c. ⁴⁾	6FX5002-5CS52-....							
	4x10	1.5	6FX 002-5CS61-....	20 (0.79)	19.4 (0.76)	6FX 008-1BB51-....	0.73 (1)	0.63 (1)	360 (14.17)	210 (8.27)
		3	6FX 002-5CS13-....							
o.c. ⁴⁾		6FX5002-5CS62-....								
Ring terminal ends	4x6	1.5	6FX 002-5CS54-....	15.6 (0.61)	16 (0.63)	6FX 008-1BB41-....	0.37 (0.8)	0.42 (0.9)	245 (9.65)	170 (6.69)
	4x10	1.5	6FX 002-5CS64-....	20 (0.79)	19.4 (0.76)	6FX5008-1BB51-....	0.73 (1)	0.63 (1)	360 (14.17)	210 (8.27)
	4x16	3	6FX 002-5CS23-....	24.2 (0.95)	23.6 (0.93)	6FX5008-1BB61-....	1.10 (2)	0.95 (2)	440 (17.32)	260 (10.24)
	4x25	-	-	28 (1.1)	-	6FX5008-1BB25-....	1.62 (4)	-	505 (19.88)	-
	4x35	-	-	31.5 (1.24)	-	6FX5008-1BB35-....	1.93 (4)	-	570 (22.44)	-
	4x50	-	-	38 (1.5)	-	6FX5008-1BB50-....	3.04 (7)	-	685 (26.97)	-
	4x70	-	-	42.6 (1.68)	-	6FX5008-1BB70-....	3.96 (9)	-	770 (30.32)	-
	4x95	-	-	51.7 (2.04)	-	6FX5008-1BB05-....	5.55 (12)	-	935 (36.81)	-
	4x120	-	-	56 (2.2)	-	6FX5008-1BB12-....	6.69 (15)	-	1010 (39.76)	-
	4x150	-	-	63 (2.48)	-	6FX5008-1BB15-....	8.21 (18)	-	1135 (44.69)	-
	4x185	-	-	66.2 (2.61)	-	6FX5008-1BB18-....	9.82 (22)	-	1195 (47.05)	-

MOTION-CONNECT 500
MOTION-CONNECT 800

5
8

5
8

Length code

....

....

Pre-assembled MOTION-CONNECT 500 power cables *without* brake cores for explosion-proof motors

Connection method, Motor Module end	Number of cores x cross section mm ²	Pre-assembled cable for 1FS6 motors (temperature-resistant up to 100 °C (212 °F))	D_{max}	Weight (without connector)	Smallest perm. bending radius ³⁾
		Order No.	6FX50 mm (in)	6FX50 kg/m (lb/ft)	6FX50 mm (in)
Pin terminal ends	4x1.5	6FX5002-5XA00-....	10.4 (0.41)	0.160 (0.4)	190 (7.48)
	4x2.5	6FX5002-5XA10-....	12.1 (0.48)	0.235 (0.5)	220 (8.66)
	4x4	6FX5002-5XA20-....	13.2 (0.52)	0.300 (0.7)	240 (9.45)
	4x6	6FX5002-5XA30-....	15.3 (0.6)	0.400 (0.9)	280 (11.02)

Length code

....

- Power cables with connector for Motor Modules are available on request with crimped contacts and a connector housing as a separately supplied accessory.
- Power cables of 1.5 mm² and 2.5 mm² are supplied in coils or on disposable drums in lengths of 50 m (164 ft), 100 m (328 ft), 200 m (656 ft) and 500 m (1640 ft). Power cables of ≥ 4 mm² can be ordered to the meter in lengths of up to 100 m (328 ft).

- Valid for routing in cable carrier.
- o. c. = Open core ends; suitable for motors with terminal box.
- Attached connector for booksize Motor Module from 3 A to 30 A

Selection and ordering data (continued)

MOTION-CONNECT power cables without brake cores for Power Modules

Connection method, at Power Module end	Number of cores x cross section mm ²	Connector size, motor end	Pre-assembled cable for 1FT/1FK motors		D _{max}		Cables by the meter ²⁾		Weight (without connector)		Smallest perm. bending radius ³⁾	
			Order No.	6FX5 mm (in)	6FX8 mm (in)	Order No.	6FX5 kg/m (lb/ft)	6FX8 kg/m (lb/ft)	6FX5 mm (in)	6FX8 mm (in)		
Cores cut	4x1.5	1	6FX 002-5CG01-....	8.4 (0.33)	10.4 (0.41)	6FX 008-1BB11-....	0.12 (0.3)	0.16 (0.4)	155 (6.1)	100 (3.94)		
		1.5	6FX 002-5CG21-....									
	4x2.5	1	6FX 002-5CG11-....	10 (0.39)	12.1 (0.48)	6FX 008-1BB21-....	0.21 (0.5)	0.23 (0.5)	180 (7.09)	120 (4.72)		
		1.5	6FX 002-5CG31-....									
	4x4	1.5	6FX 002-5CG41-....	11.4 (0.45)	13.2 (0.52)	6FX 008-1BB31-....	0.27 (0.6)	0.31 (0.7)	210 (8.27)	130 (5.12)		
	4x6	1.5	6FX 002-5CG51-....	13.6 (0.54)	16 (0.63)	6FX 008-1BB41-....	0.37 (0.8)	0.42 (0.9)	245 (9.65)	170 (6.69)		
4x10	1.5	6FX 002-5CG61-....	20 (0.79)	19.4 (0.76)	6FX 008-1BB51-....	0.73 (1)	0.63 (1)	360 (14.17)	210 (8.27)			
	3	6FX 002-5CG13-....										
4x16	3	6FX 002-5CG23-....	24.2 (0.95)	23.6 (0.93)	6FX5008-1BB61-....	1.10 (2)	0.95 (2)	440 (17.32)	260 (10.24)			

MOTION-CONNECT 500
MOTION-CONNECT 800

5
8

5
8

Length code

....

....

MOTION-CONNECT power cables with brake cores for Motor Modules

Connection method, at Motor Module end ¹⁾	Number of cores x cross section mm ²	Connector size, motor end	Pre-assembled cable for 1FT/1FK motors		D _{max}		Cable (sold by meter) ²⁾ for motors with terminal box		Weight (without connector)		Smallest perm. bending radius ³⁾	
			Order No.	6FX5 mm (in)	6FX8 mm (in)	Order No.	6FX5 kg/m (lb/ft)	6FX8 kg/m (lb/ft)	6FX5 mm (in)	6FX8 mm (in)		
Connector ⁴⁾	4x1.5+2x1.5	0.5	6FX5002-5DA20-....	10.8 (0.43)	12.9 (0.51)	6FX 008-1BA11-....	0.22 (0.4)	0.25 (0.6)	195 (7.68)	125 (4.92)		
		1	6FX 002-5DS01-....									
		1.5	6FX 002-5DS21-....									
	4x2.5+2x1.5	1	6FX 002-5DS11-....	12.4 (0.49)	14.2 (0.56)	6FX 008-1BA21-....	0.25 (0.6)	0.31 (0.7)	225 (8.86)	140 (5.51)		
		1.5	6FX 002-5DS31-....									
	4x4+2x1.5	1.5	6FX 002-5DS41-....	14 (0.55)	15.3 (0.6)	6FX 008-1BA31-....	0.35 (0.8)	0.4 (0.9)	255 (10.04)	150 (5.9)		
	4x6+2x1.5	1.5	6FX 002-5DS51-....	16.1 (0.63)	17.8 (0.7)	6FX 008-1BA41-....	0.49 (1)	0.53 (1.2)	290 (11.42)	195 (7.68)		
	4x10+2x1.5	1.5	6FX 002-5DS61-....	21.7 (0.85)	20.8 (0.82)	6FX 008-1BA51-....	0.81 (1.8)	0.78 (1.7)	395 (15.55)	230 (9.06)		
		3	6FX 002-5DS13-....									
Ring terminal ends	4x6+2x1.5	1.5	6FX 002-5DS54-....	16.1 (0.63)	17.8 (0.7)	6FX 008-1BA41-....	0.49 (1) (1.2)	0.53 (1.2)	290 (11.42)	195 (7.68)		
	4x10+2x1.5	1.5	6FX 002-5DS64-....	21.7 (0.85)	20.8 (0.82)	6FX 008-1BA51-....	0.81 (1.8)	0.78 (1.7)	395 (15.55)	230 (9.06)		
	4x16+2x1.5	3	6FX 002-5DS23-....	25 (0.98)	24.7 (0.97)	6FX 008-1BA61-....	1.12 (2.5)	1.05 (2.3)	450 (17.72)	275 (10.83)		
	4x25+2x1.5	3	6FX 002-5DS33-....	29.4 (1.16)	27.9 (1.1)	6FX 008-1BA25-....	1.62 (3.6)	1.51 (3.3)	530 (20.87)	325 (12.79)		
	4x35+2x1.5	3	6FX 002-5DS43-....	32.6 (1.28)	32 (1.26)	6FX 008-1BA35-....	2.06 (4.5)	2 (4.4)	590 (23.23)	380 (14.96)		
	4x50+2x1.5	3	6FX 002-5DS53-....	38 (1.5)	35.8 (1.41)	6FX 008-1BA50-....	3.04 (6.7)	2.66 (5.9)	685 (26.97)	420 (16.54)		

MOTION-CONNECT 500
MOTION-CONNECT 800

5
8

5
8

Length code

....

....

- Power cables with connector for Motor Modules are available on request with crimped contacts and a connector housing as a separately supplied accessory.
- Power cables of 1.5 mm² and 2.5 mm² are supplied in coils or on disposable drums in lengths of 50 m (164 ft), 100 m (328 ft), 200 m (656 ft) and 500 m (1640 ft). Power cables of ≥ 4 mm² can be ordered to the meter in lengths of up to 100 m (328 ft).

- Valid for routing in cable carrier.
- Attached connector for booksize Motor Module from 3 A to 30 A.

MOTION-CONNECT connection system

Power cables

Selection and ordering data (continued)

Power cable extensions for Motor Modules

Number of cores x cross section mm ²	Basic cable for 1FT/1FK motors	Connector size	Extension	Connector size
	Type		Order No.	
4x1.5	6FX5002-5DA20-....	0.5	6FX5002-5ME05-....	0.5
	6FX . 002-5 . S01-....	1	6FX ■002-5 ■A05-....	1
	6FX . 002-5 . S21-....	1.5	6FX ■002-5 ■A28-....	1.5
4x2.5	6FX . 002-5 . S11-....	1	6FX ■002-5 ■A15-....	1
	6FX . 002-5 . S31-....	1.5	6FX ■002-5 ■A38-....	1.5
4x4	6FX . 002-5 . S41-....	1.5	6FX ■002-5 ■A48-....	1.5
4x6	6FX . 002-5 . S51-....	1.5	6FX ■002-5 ■A58-....	1.5
4x10	6FX . 002-5 . S61-....	1.5	6FX ■002-5 ■A68-....	1.5
	6FX . 002-5 . S13-....	3	6FX ■002-5 ■X18-....	3
4x16	6FX . 002-5 . S23-....	3	6FX ■002-5 ■X28-....	3
4x25	6FX . 002-5DS33-....	3	6FX ■002-5DX38-....	3
4x35	6FX . 002-5DS43-....	3	6FX ■002-5DX48-....	3
4x50	6FX . 002-5DS53-....	3	6FX ■002-5DX58-....	3

MOTION-CONNECT 500
MOTION-CONNECT 800

5
8

Without brake cores
With brake cores

C
D

Length code

....

The combinations of power cable extensions shown are examples only.

Note : The maximum specified cable length (basic cable and extensions) must not be exceeded. The total maximum permissible length is reduced by 2 m (6.56 ft) for each interruption point.

MOTION-CONNECT power cables with brake cores for Power Modules

Connection method, Power Module end	Number of cores x cross section mm ²	Connector size, motor end	Pre-assembled cable for 1FT/1FK motors	D_{max}	Cables by the meter ¹⁾		Weight (without connector)		Smallest perm. bending radius ²⁾	
			Order No.		6FX5 mm (in)	6FX8 mm (in)	Order No.	6FX5 kg/m (lb/ft)	6FX8 kg/m (lb/ft)	6FX5 mm (in)
Cores cut	4x1.5+2x1.5	0.5	6FX5002-5ME00-....	10.8 (0.43)	-	-	0.22 (0.4)	-	195 (7.68)	-
		1	6FX ■002-5DG01-....	10.8 (0.43)	12.9 (0.51)	6FX ■008-1BA11-....	0.22 (0.4)	0.25 (0.6)	195 (7.68)	125 (4.92)
		1.5	6FX ■002-5DG21-....							
	4x2.5+2x1.5	1	6FX ■002-5DG11-....	12.4 (0.49)	14.2 (0.56)	6FX ■008-1BA21-....	0.25 (0.6)	0.31 (0.7)	225 (8.86)	140 (5.51)
		1.5	6FX ■002-5DG31-....							
	4x4+2x1.5	1.5	6FX ■002-5DG41-....	14 (0.55)	15.3 (0.6)	6FX ■008-1BA31-....	0.35 (0.8)	0.4 (0.9)	255 (10.04)	150 (5.9)
4x6+2x1.5	1.5	6FX ■002-5DG51-....	16.1 (0.63)	17.8 (0.7)	6FX ■008-1BA41-....	0.49 (1) (1.2)	0.53 (1.2)	290 (11.42)	195 (7.68)	
4x10+2x1.5	1.5	6FX ■002-5DG61-....	21.7 (0.85)	20.8 (0.82)	6FX ■008-1BA51-....	0.81 (1.8)	0.78 (1.7)	395 (15.55)	230 (9.06)	
	3	6FX ■002-5DG13-....								
4x16+2x1.5	3	6FX ■002-5DG23-....	25 (0.98)	24.7 (9.72)	6FX ■008-1BA61-....	1.12 (2.5)	1.05 (2.3)	450 (17.72)	275 (10.83)	
4x25+2x1.5	3	6FX ■002-5DG33-....	29.4 (1.16)	27.9 (1.1)	6FX ■008-1BA25-....	1.62 (3.6)	1.51 (3.3)	530 (20.87)	325 (12.79)	
4x35+2x1.5	3	6FX ■002-5DG43-....	32.6 (1.28)	32 (1.26)	6FX ■008-1BA35-....	2.06 (4.5)	2 (4.4)	590 (23.23)	380 (14.96)	
4x50+2x1.5	3	6FX ■002-5DG53-....	38 (1.5)	35.8 (1.41)	6FX ■008-1BA50-....	3.04 (6.7)	2.66 (5.9)	685 (26.97)	420 (16.54)	

MOTION-CONNECT 500
MOTION-CONNECT 800

5
8

5
8

Length code

....

....

¹⁾ Power cables of 1.5 mm² and 2.5 mm² are supplied in coils or on disposable drums in lengths of 50 m (164 ft), 100 m (328 ft), 200 m (656 ft) and 500 m (1640 ft). Power cables of ≥ 4 mm² can be ordered to the meter in lengths of up to 100 m (328 ft).

²⁾ Valid for routing in cable carrier.

Selection and ordering data (continued)

Power cable extensions for Power Modules

Number of cores x cross section mm ²	Basic cable for 1FT/1FK motors	Connector size	Extension	Connector size
	Type		Order No.	
4x1.5	6FX5002-5ME00-....	0.5	6FX5002-5ME05-....	0.5
	6FX . 002-5CG01-....	1	6FX 002-5 A05-....	1
	6FX . 002-5CG21-....	1.5	6FX 002-5 A28-....	1.5
4x2.5	6FX . 002-5CG11-....	1	6FX 002-5 A15-....	1
	6FX . 002-5CG31-....	1.5	6FX 002-5 A38-....	1.5
4x4	6FX . 002-5CG41-....	1.5	6FX 002-5 A48-....	1.5
4x6	6FX . 002-5CG51-....	1.5	6FX 002-5 A58-....	1.5
4x10	6FX . 002-5CG61-....	1.5	6FX 002-5 A68-....	1.5
	6FX . 002-5CG13-....	3	6FX 002-5 X18-....	3
4x16	6FX . 002-5CG23-....	3	6FX 002-5 X28-....	3
4x25	6FX . 002-5DG33-....	3	6FX 002-5DX38-....	3
4x35	6FX . 002-5DG43-....	3	6FX 002-5DX48-....	3
4x50	6FX . 002-5DG53-....	3	6FX 002-5DX58-....	3
MOTION-CONNECT 500			5	
MOTION-CONNECT 800			8	
Without brake cores			C	
With brake cores			D	
Length code			

The combinations of power cable extensions shown are examples only.

Note: The maximum specified cable length (basic cable and extensions) must not be exceeded. The total maximum permissible length is reduced by 2 m (6.56 ft) for each interruption point.

Pre-assembled MOTION-CONNECT 500 power cables for 1PH7 motors

Motor	Armour thread	Number of cores x cross section	Pre-assembled cable for 1PH7 motors	Weight by the meter	Smallest perm. bending radius ¹⁾
Type	Size	mm ²	Order No.	kg/m (lb/ft)	mm (in)
1PH710	PG29	4x16	6FX5002-5CH16-....	1.10 (2)	440 (17.32)
1PH713	PG36	4x16	6FX5002-5CJ16-....	1.10 (2)	440 (17.32)
1PH716	PG42	4x25	6FX5002-5CK25-....	1.56 (3)	530 (20.87)
Length code				

¹⁾ Valid for routing in cable carrier.

MOTION-CONNECT connection system

Accessories for power cables

Flange and HF clamp

Overview

Flange



Flanges are used to route or fix connectors, for example, in control cabinets. With the exception of angled connectors, a flange can be retro-mounted on connectors with a union nut or connectors with external threads.

HF (high-frequency) clamp

To permit correct "grounding" on the cable duct or cabinet wall, a ground clamp can be ordered as an accessory together with the flanges for large-area discharging of high-frequency interferences.

Selection and Ordering Data

Description	Order No.
Flange for	
• Connector size 1	6FX2003-7BX00
• Connector size 1.5	6FX2003-7CX00
• Connector size 3	6FX2003-7AX00
HF clamp for	
• Connector size 1	6FX2003-7FX00
• Connector size 1.5	6FX2003-7GX00
• Connector size 3	Not required

Dimensional drawings

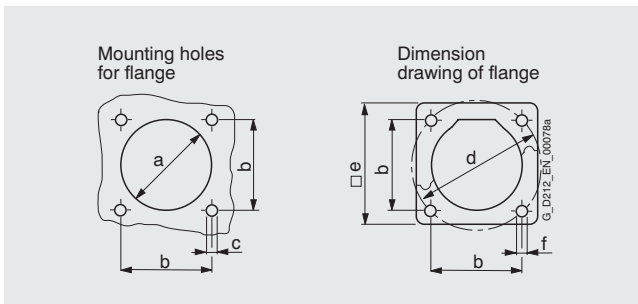

Dimension	Connector size 1	Connector size 1.5	Connector size 3
	mm (in)	mm (in)	mm (in)
a	∅ 27.8 (1.09)	∅ 46 (1.81)	∅ 65 (2.56)
b	28.3 (1.11)	42.4 (1.67)	75 (2.95)
c	M3 (4x)	M4 (4x)	M4 (4x)
d	∅ 40 (1.57)	∅ 60 (2.36)	∅ 63 (2.48)
e	35 (1.38)	55 (2.17)	85 (3.35)
f	∅ 3.2 (0.13)	∅ 4.4 (0.17)	∅ 4.5 (0.18)

Power connector for SINAMICS Motor Modules

Overview



Power connector with screw-type connection

3 A to 30 A Motor Modules in booksize format are shipped without power supply connector, as this is already connected to the MOTION-CONNECT power cables.

Power connectors can also be ordered separately, e.g. for applications where routing of the motor cable would be difficult if a power connector were attached. Power connectors with crimp or screw-type terminal are available.

Selection and Ordering Data

Description	Order No.
Power connector for 3 A to 30 A Motor Modules booksize format with screw terminal (housing, insulator, 2 coding pins, screw terminals motor: 1.5 mm ² to 10 mm ² , brake: 1.5 mm ²)	6SL3162-2MA00-0AA0
Power connector without pin contacts for Motor Modules 3 A to 30 A booksize format suitable for pin contacts with crimp terminal (housing, insulator, 2 coding pins)	6FX2003-1SA00
Pin contacts for power connector (25 contacts per pack)	
• 1.5 mm ² (power and brake)	6FX2003-8PS10
• 2.5 mm ² (power)	6FX2003-8PS20
• 4 mm ² (power)	6FX2003-8PS30
• 6 mm ² (power)	6FX2003-8PS40
• 10 mm ² (power)	6FX2003-8PS50

Overview



MOTION-CONNECT DRIVE-CLiQ cable

Signal cables are pre-assembled and are sold by the meter for the connection of a variety of components.

The following different types of cable are available:

- DRIVE-CLiQ cables
- MOTION-CONNECT DRIVE-CLiQ cables
- MOTION-CONNECT pre-assembled cables

Application

DRIVE-CLiQ cables

DRIVE-CLiQ cables are used to connect components with DRIVE-CLiQ connections which have a separate or external 24 V DC power supply.

DRIVE-CLiQ cables for connecting Line/Motor Modules with a Control Unit are part of the scope of supply of the relevant Line/Motor Modules.

MOTION-CONNECT DRIVE-CLiQ cables

MOTION-CONNECT DRIVE-CLiQ cables are used whenever components with DRIVE-CLiQ connections must meet high requirements, such as mechanical stress and oil resistance, e.g. with a connection outside the cabinet between

- Motor Modules and Sensor Modules
- Motor Modules and motors with DRIVE-CLiQ interface

MOTION-CONNECT DRIVE-CLiQ cables feature 24 V DC cores.

MOTION-CONNECT pre-assembled cables

MOTION-CONNECT pre-assembled cables are used whenever motor encoders on motors without DRIVE-CLiQ interface are connected to Sensor Modules.

Note : All 6FX.002-2C.. signal cables are available with crimped contacts and with the connector housing supplied separately.

- Signal cables with separately supplied **motor-end** connector housing: 6FX.042-2C...-1.. (**4** in 6th position)
- Signal cables with separately supplied **module-end** connector housing: 6FX.012-2C...-1.. (**1** in 6th position)

Integration

Connection overview CU320 Control Unit in booksize format

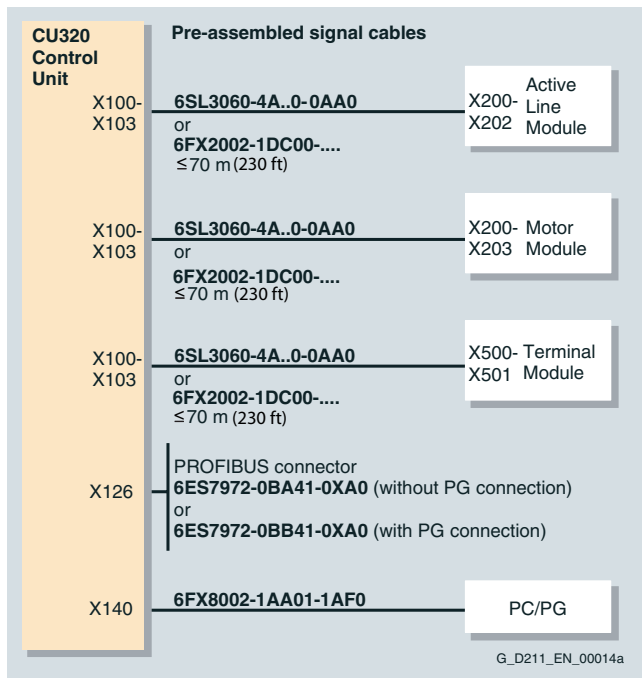

Connection overview CU320 Control Unit in chassis format

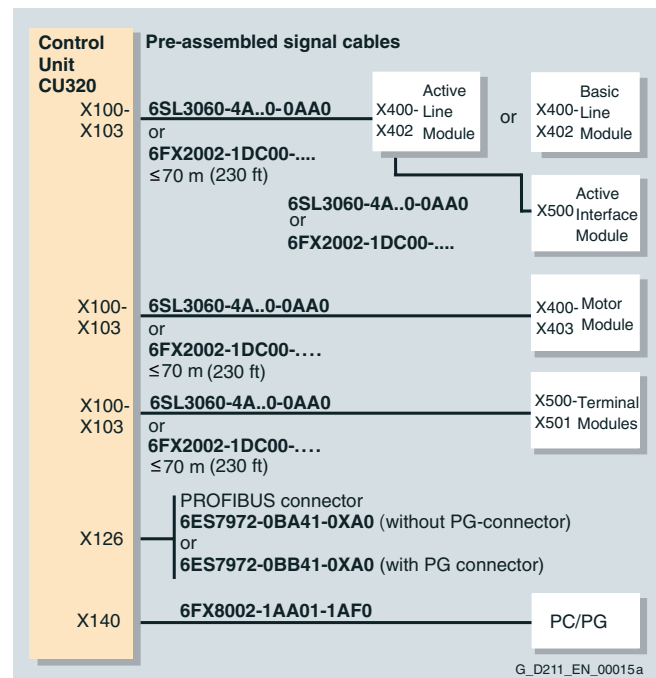

Signal cables

Integration (continued)

Connection overview Line Modules and Motor Modules in booksize format

The DRIVE-CLiQ cables type 6SL3060-4A...0-0AA0 required for the standard configuration are part of the scope of supply of the Line Modules and Motor Modules. In this case, the modules should be mounted directly adjacent to one another in a row.

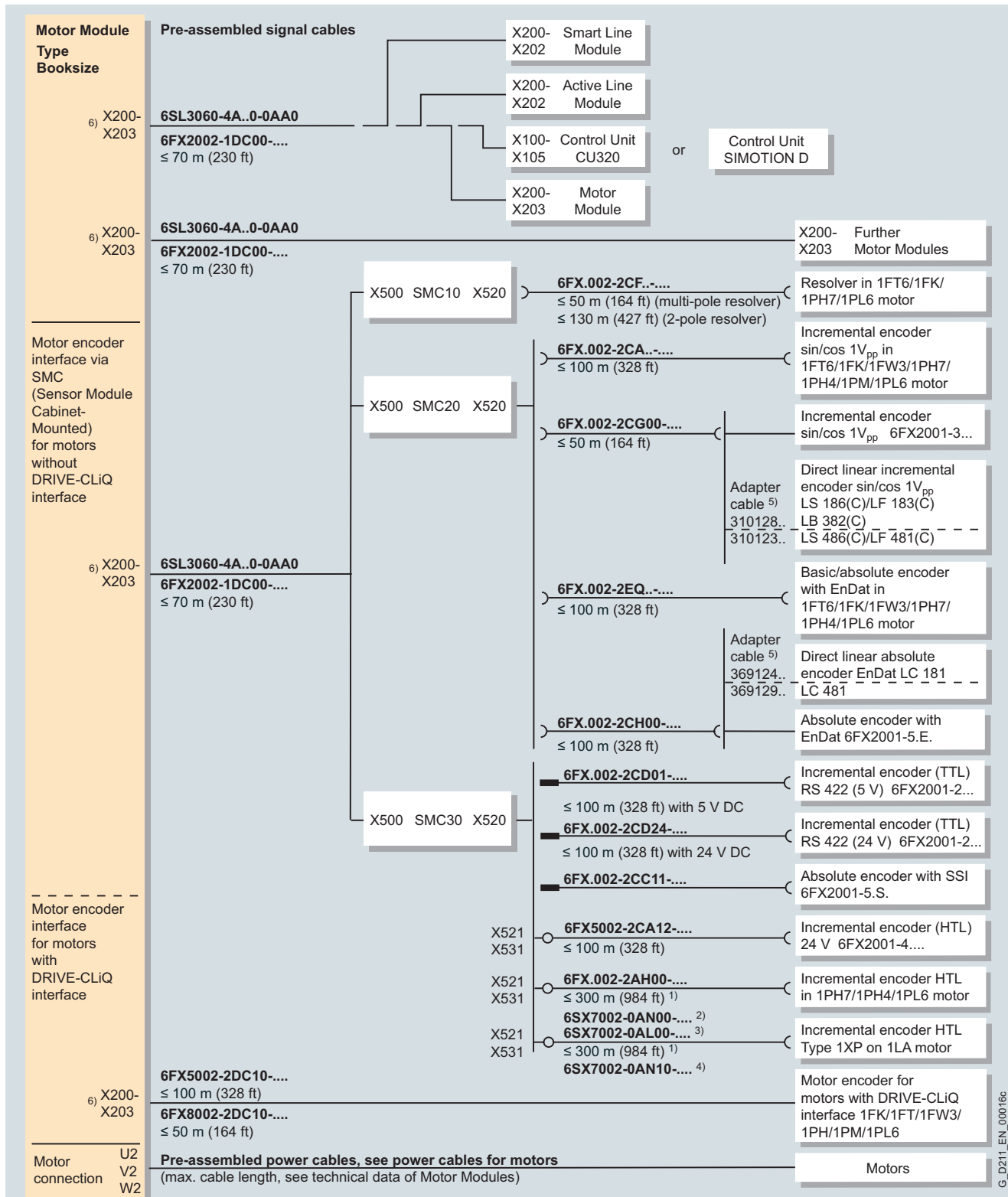

1) With evaluation of signals A*, A and B*, B, otherwise ≤ 100 m (328 ft).
 2) Tracks A*, A, B*, B, R*, R.
 3) Tracks A, B.
 4) With right-angled connector.

5) Cable available from measuring system manufacturer. www.heidenhain.de
 6) For Single Motor Module: X200-X202
 For Double Motor Module: X200-X203.

Integration (continued)

Connection overview Line Modules and Motor Modules in chassis format

The DRIVE-CLiQ cables type 6SL3060-4A...0-0AA0 required for the standard configuration are part of the scope of supply of the Line Modules and Motor Modules. In this case, the modules should be mounted directly adjacent to one another in a row.

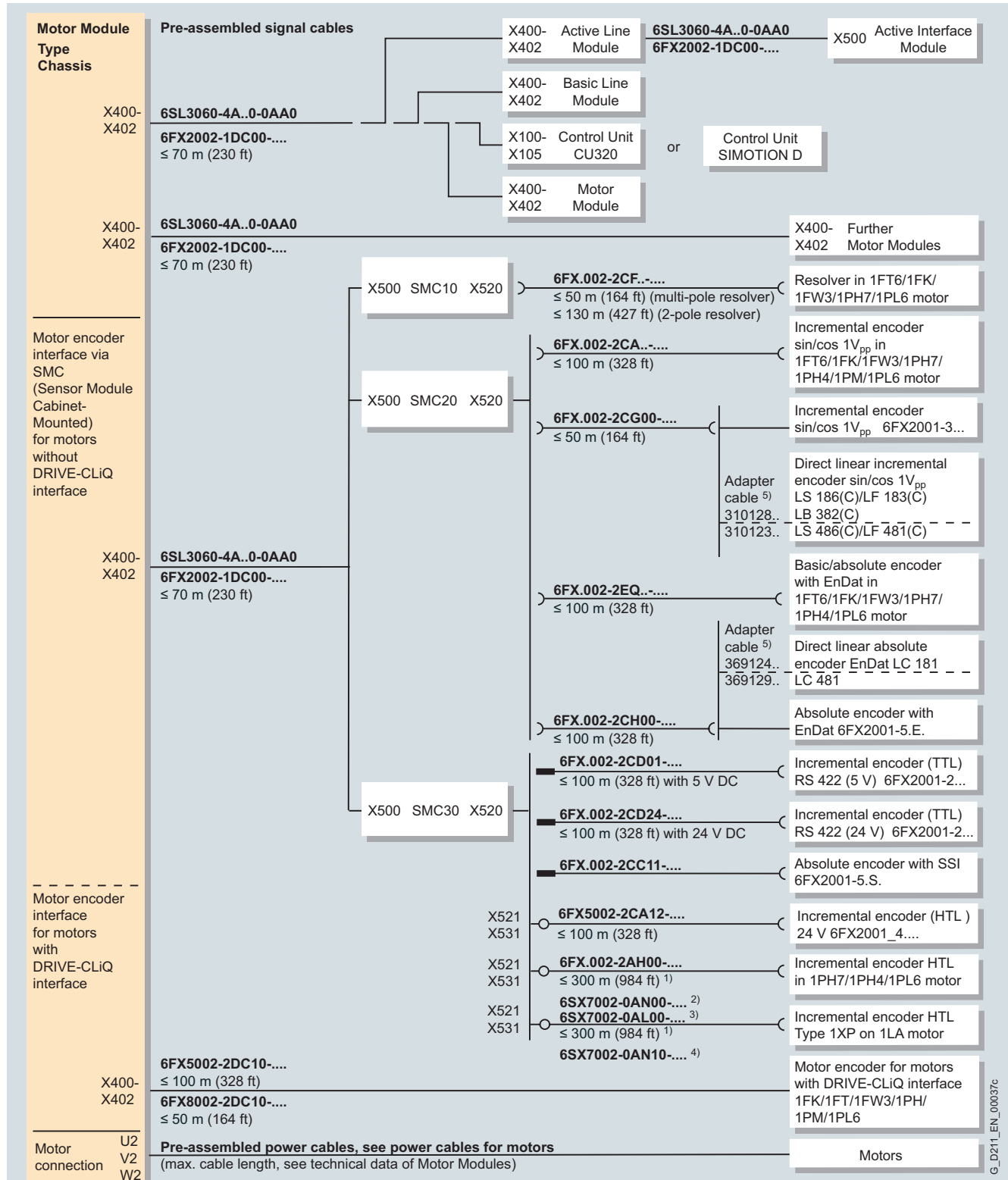

1) With evaluation of signals A*, A and B*, B, otherwise ≤ 100 m (328 ft).
 2) Tracks A*, A, B*, B, R*, R.
 3) Tracks A, B.

4) With right-angled connector.
 5) Cable available from measuring system manufacturer.
www.heidenhain.de

Signal cables

Integration (continued)

Connection overview Power Modules in chassis format

A DRIVE-CLiQ cable type 6SL3060-4A...0-0AA0 required for the connection to the CU310 Control Unit, which is mounted into the chassis unit, is already part of the scope of supply.

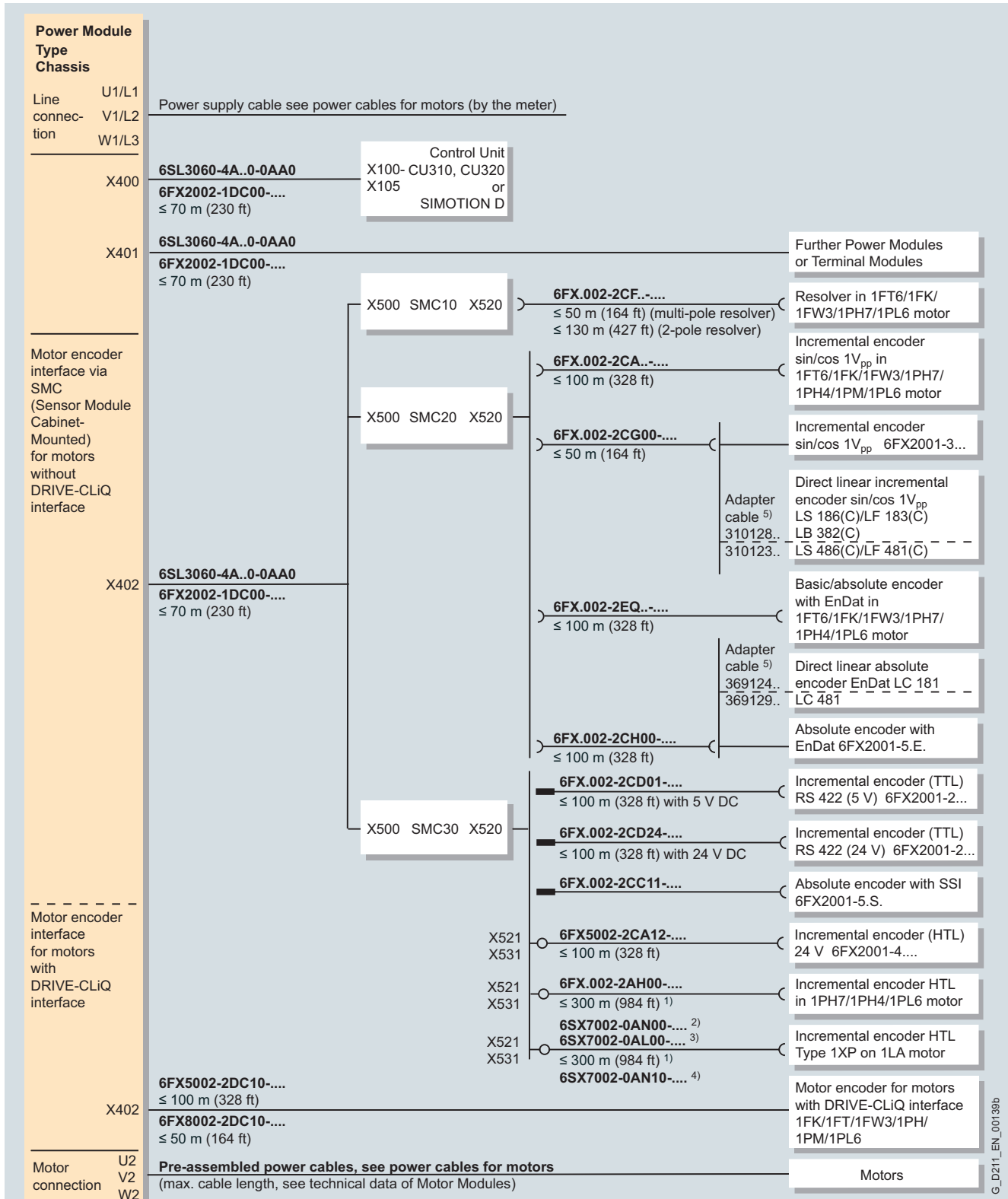

G_D211_EN_00139b

1) With evaluation of signals A*, A and B*, B, otherwise ≤ 100 m (328 ft).
 2) Tracks A*, A, B*, B, R*, R.
 3) Tracks A, B.

4) With right-angled connector.
 5) Cable available from measuring system manufacturer.
www.heidenhain.de

Integration (continued)

Connection overview Power Modules in blocksize format with CUA31 Control Unit Adapter

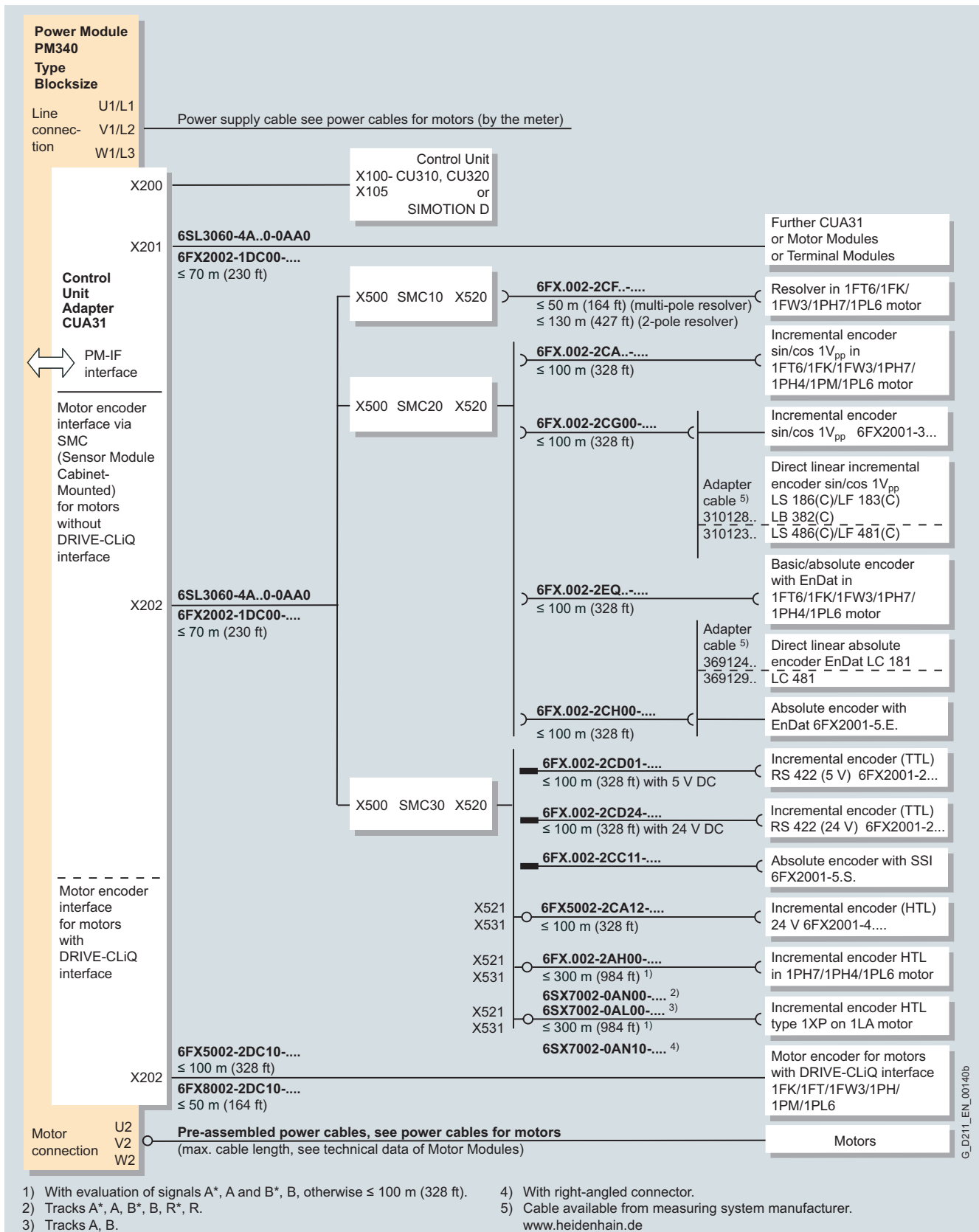

Signal cables

Integration (continued)

Connection overview Power Modules in blocksize format with CU310 Control Unit

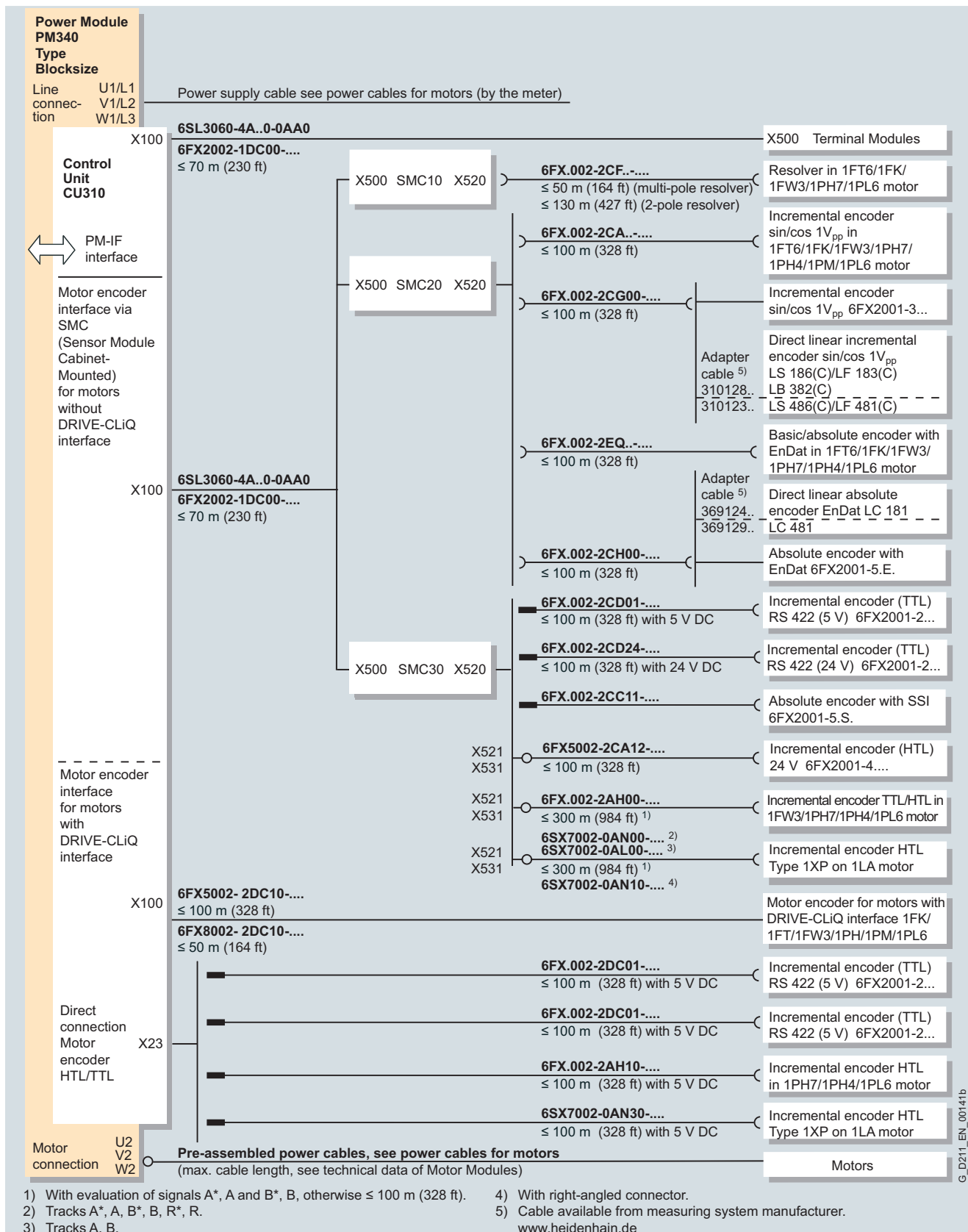

G_D211_EN_00141b

Integration (continued)

Connection of a machine encoder (direct measuring system)

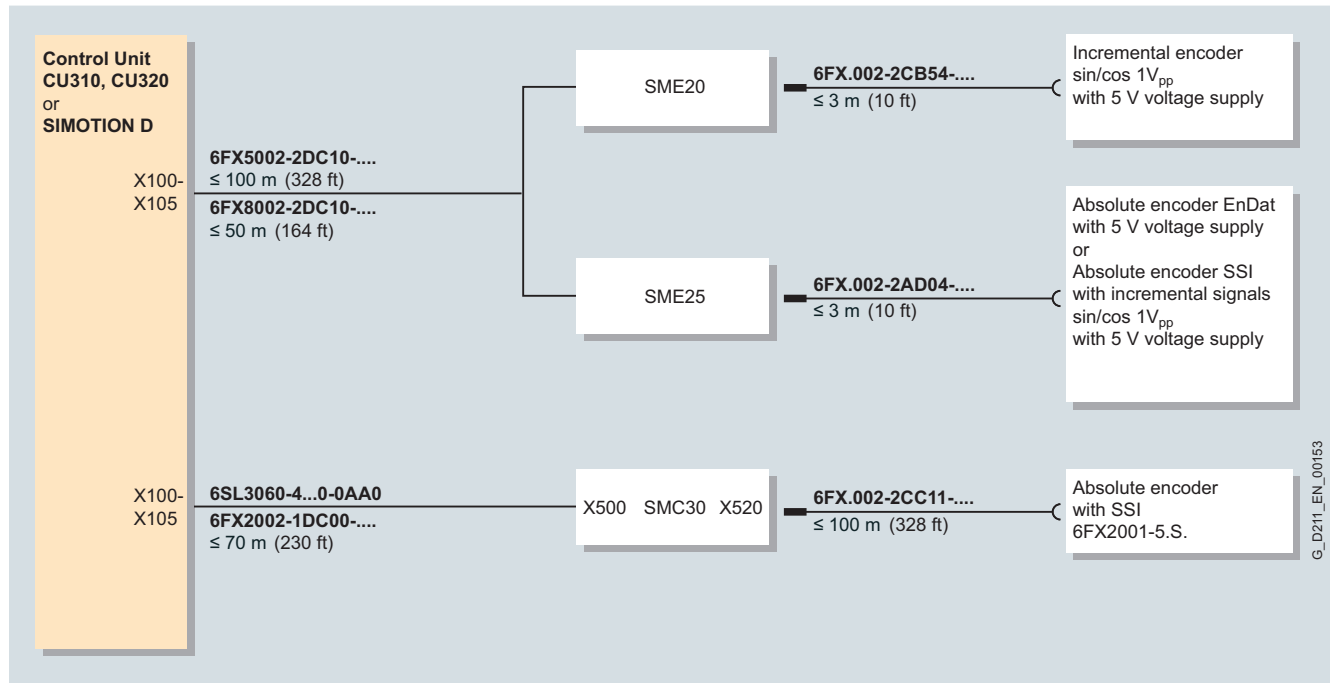

Selection and Ordering Data

Signal cable	Length	Degree of protection (connector)	Basic cable	Extensions
			Order No.	Order No.
DRIVE-CLiQ pre-assembled cables (without 24 V DC cores)				
In specific lengths	0.11 m (0.36 ft)	IP20/IP20	6SL3060-4AB00-0AA0	—
	0.16 m (0.52 ft)		6SL3060-4AD00-0AA0	—
	0.21 m (0.69 ft)		6SL3060-4AF00-0AA0	—
	0.26 m (0.85 ft)		6SL3060-4AH00-0AA0	—
	0.31 m (1.02 ft)		6SL3060-4AK00-0AA0	—
	0.36 m (1.18 ft)		6SL3060-4AM00-0AA0	—
	0.41 m (1.35 ft)		6SL3060-4AP00-0AA0	—
	0.60 m (1.97 ft)		6SL3060-4AU00-0AA0	—
	0.95 m (3.12 ft)		6SL3060-4AA10-0AA0	—
	1.20 m (3.94 ft)		6SL3060-4AW00-0AA0	—
	1.45 m (4.76 ft)		6SL3060-4AF10-0AA0	—
	2.80 m (9.19 ft)		6SL3060-4AJ20-0AA0	—
5.00 m (16.4 ft)	6SL3060-4AA50-0AA0	—		
By the meter	max. 70 m (230 ft)	IP20/IP20	6FX2002-1DC00-....	—
	max. 70 m (230 ft)	IP67/IP67	6FX2002-1DC20-....	—
MOTION-CONNECT 500 DRIVE-CLiQ cables (with 24 V DC cores)				
By the meter	max. 100 m (328 ft)	IP20/IP20	6FX0002-2DC00-....	—
	max. 100 m (328 ft)	IP20/IP67	6FX5002-2DC10-....	—
	max. 100 m (328 ft)	IP67/IP67 ¹⁾	6FX5002-2DC20-....	—
MOTION-CONNECT 800 DRIVE-CLiQ cables (with 24 V DC cores)				
By the meter	max. 50 m (164 ft)	IP20/IP20	6FX8002-2DC00-....	—
	max. 50 m (164 ft)	IP20/IP67	6FX8002-2DC10-....	—
	max. 50 m (164 ft)	IP67/IP67 ¹⁾	6FX8002-2DC20-....	—
MOTION-CONNECT 500			5	
MOTION-CONNECT 800			8	
Length code			

¹⁾ No direct connection to the modules

Signal cables

Selection and Ordering Data (continued)

Signal cable	Length	Degree of protection (connector)	Basic cable Order No.	Extensions Order No.	
Pre-assembled cables for built-in encoder on 1FT6/1FK7/1PH/1FW3 motors					
Resolver	SMC10	max. 50 m (164 ft)	IP20/IP67	6FX002-2CF02-....	6FX002-2CF04-....
Incremental encoder sin/cos 1 V _{pp}	SMC20	max. 50 m (164 ft)	IP20/IP67	6FX002-2CA31-....	6FX002-2CA34-....
EnDat absolute encoder	SMC20	max. 50 m (164 ft)	IP20/IP67	6FX002-2EQ10-....	6FX002-2EQ14-....
Incremental encoder sin/cos 1 V _{pp} 6FX2001-3... ECS spindle	SMC20	max. 50 m (164 ft)	IP20/IP67	6FX8002-2CA80-....	–
Incremental encoder in 1PH7/1PH4 motor	SMC30, TTL	max. 100 m (328 ft)	IP20/IP67	6FX002-2AH00-....	6FX002-2AH04-....
	SMC30, HTL	max. 300 m (984 ft)			
Incremental encoder in 1PH7/1PH4/1PL6 motor • Track A*, A, B*, B, R*, R	CU310, TTL, HTL	max. 100 m (328 ft)	IP20/IP67	6FX002-2AH10-....	–
	CU310, HTL with differential signal evaluation	max. 300 m (984 ft)			
	CU310, HTL	max. 100 m (328 ft)			
Incremental encoder in 1LA motor • Track A*, A, B*, B, R*, R	CU310, HTL with differential signal evaluation	max. 300 m (984 ft)	IP20/IP67	6FX7002-0AN30-....	–
Pre-assembled cables for built-in encoder on 1FS6 explosion-proof motors					
Incremental encoder sin/cos 1 V _{pp}	SMC20	max. 50 m (164 ft)	IP20/IP67	6FX5002-2XA00-....	–
Absolute encoder with EnDat	SMC20	max. 50 m (164 ft)	IP20/IP67	6FX5002-2XQ10-....	–
PTC thermistor (for connection to 3RN10 triggering device)	–	Unlimited	–	6FX5002-2XA04-....	–
Pre-assembled cables for built-in encoder on 1FT6/1FK7/1PH/1FW3 motors					
Resolver	SMC10	max. 50 m (164 ft)	IP20/IP67	6FX5002-2CF20-....	–
Incremental encoder sin/cos 1 V _{pp}	SMC20	max. 50 m (164 ft)	IP20/IP67	6FX5002-2CA20-....	–
EnDat absolute encoder	SMC20	max. 50 m (164 ft)	IP20/IP67	6FX5002-2EQ20-....	–
Pre-assembled cables for built-on rotary encoder					
Incremental encoder sin/cos 1 V _{pp} 6FX2001-3...	SMC20	max. 50 m (164 ft)	IP20/IP67	6FX002-2CG00-....	6FX002-2CB54-....
				6FX002-2CA11-....	6FX002-2CB54-....
Absolute encoder with EnDat 6FX2001-5.E.	SMC20	max. 50 m (164 ft)	IP20/IP67	6FX002-2CH00-....	6FX002-2AD04-....
				6FX002-2AD00-....	6FX002-2AD04-....
Incremental encoder (TTL) RS 422 (5 V) 6FX2001-2...	SMC30	max. 50 m (164 ft)	IP20/IP67	6FX002-2CA72-....	6FX002-2CB54-....
		max. 100 m (328 ft)	IP20/IP67	6FX002-2CD01-....	6FX002-2CB54-....
Incremental encoder (TTL) RS 422 (24 V) 6FX2001-2...	SMC30	max. 100 m (328 ft)	IP20/IP67	6FX002-2CD24-....	6FX002-2CB54-....
		–	–	–	–
Absolute encoder with SSI 6FX2001-5.S.	SMC30	Clock rate 1 MHz: max. 50 m (164 ft)	IP20/IP67	6FX002-2CC11-....	–
		Clock rate 300 kHz: max. 100 m (328 ft)			
		Clock rate 400 kHz: max. 400 m (1312 ft)			
Incremental encoder HTL type 1XP on 1LA motor • Track A, B • Track A*, A, B*, B, R*, R • Track A*, A, B*, B, R*, R with right-angled connector	SMC30	max. 100 m (328 ft)	IP20/IP67	6SX7002-0AL00-....0	–
		max. 300 m (984 ft)	IP20/IP67	6SX7002-0AN00-....0	–
		max. 300 m (984 ft)	IP20/IP67	6SX7002-0AN10-....0	–
		–	–	–	–
MOTION-CONNECT 500				5	
MOTION-CONNECT 800				8	
Length code			

The combinations of signal cable extensions shown are examples only.

Note : The maximum specified cable length (basic cable and extensions) must not be exceeded. The total maximum permissible length is reduced by 2 m (6.56 ft) for each interruption point.

Flange and HF clamp

Overview

Flange



Flanges are used to route or fix connectors, for example, in control cabinets. With the exception of angled connectors, a flange can be retro-mounted on connectors with a union nut or connectors with external thread.

HF (high-frequency) clamp

To permit correct "grounding" on the cable duct or cabinet wall, a ground clamp can be ordered as an accessory together with the flanges for large-area discharging of high-frequency interferences.

Selection and Ordering Data

Description	Order No.
Flange for signal connector	6FX2003-7DX00
HF clamp for signal connector	6FX2003-7FX00

Dimensional drawings

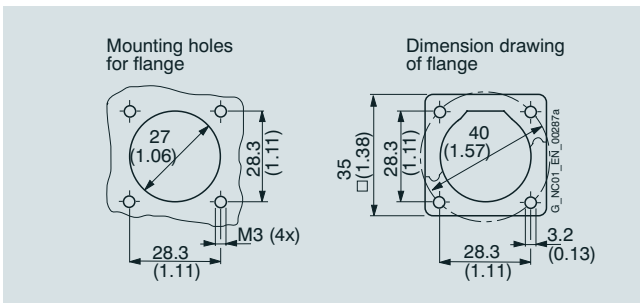

Dimensions in mm (in)

DRIVE-CLiQ cabinet conduit and coupler

Overview

DRIVE-CLiQ cabinet conduit



The DRIVE-CLiQ cabinet conduit provides a high degree of protection for MOTION-CONNECT DRIVE-CLiQ cables routed into a control cabinet. The DRIVE-CLiQ cabinet conduit offers degree of protection IP67 outside the cabinet, and IP20 inside the cabinet.

DRIVE-CLiQ coupler



The DRIVE-CLiQ coupler makes it possible to join two MOTION-CONNECT DRIVE-CLiQ cables with degree of protection IP67.

Selection and Ordering Data

Description	Order No.
DRIVE-CLiQ cabinet conduit	6SL3066-2DA00-0AA0
DRIVE-CLiQ coupler	6SL3066-2DA00-0AB0

Dimensional drawings

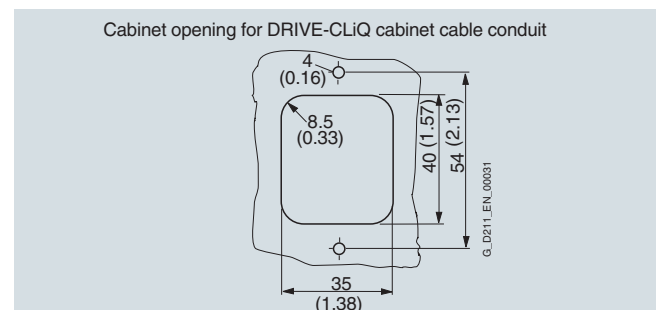

Dimensions in mm (in)

Length codes

Overview

Length codes for pre-assembled cables	Type
	6FX.....-.....- ■ ■ ■ ■ ■
	6SX.....-.....- ■ ■ ■ ■ 0
0 m (0 ft)	1
100 m (328 ft)	2
200 m (656 ft)	3
300 m (984 ft)	4
0 m (0 ft)	A
10 m (32.8 ft)	B
20 m (65.6 ft)	C
30 m (98.4 ft)	D
40 m (131.2 ft)	E
50 m (164.1 ft)	F
60 m (196.7 ft)	G
70 m (229.7 ft)	H
80 m (262.5 ft)	J
90 m (295.3 ft)	K
0 m (0 ft)	A
1 m (3.28 ft)	B
2 m (6.56 ft)	C
3 m (9.84 ft)	D
4 m (13.12 ft)	E
5 m (16.41 ft)	F
6 m (19.69 ft)	G
7 m (22.97 ft)	H
8 m (26.25 ft)	J
9 m (29.53 ft)	K
0 m (0 ft)	0
0.1 m (0.33 ft)	1
0.2 m (0.66 ft)	2
0.3 m (0.98 ft)	3
0.4 m (1.31 ft)	4
0.5 m (1.64 ft)	5
0.6 m (1.97 ft)	6
0.7 m (2.3 ft)	7
0.8 m (2.62 ft)	8

Examples:

1.0 m (3.28 ft):	1	A	B	0
2.2 m (7.22 ft):	1	A	C	2
8.0 m (26.25 ft):	1	A	J	0
299.0 m (981 ft):	3	K	K	0

Length code for power and signal cables, sold by the meter ¹⁾	Type
• 50 m (164 ft)	6FX.008-.....-1FA0
• 100 m (328 ft)	6FX.008-.....-2AA0
• 200 m (656 ft)	6FX.008-.....-3AA0
• 500 m (1640 ft)	6FX.008-.....-6AA0

Length definition for pre-assembled cables

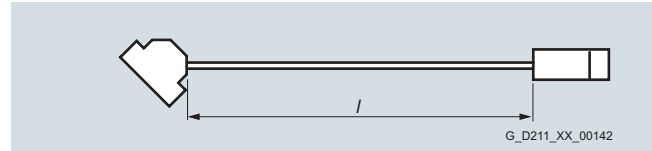

Signal cables

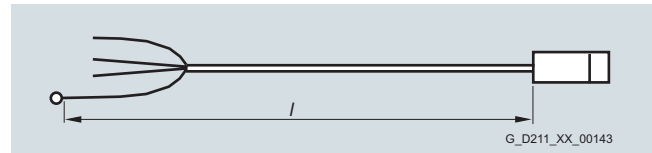

Power cables

Tolerance:

- Cable lengths of up to 10 m (32.8 ft): ± 2%
- Cable lengths of 10 m (32.8 ft) and longer: ± 1%

¹⁾ Power cables with cross-section of 4 mm² or greater can be ordered in exact meter lengths up to a length of 100 m (328 ft). Power cables with cross-sections of 1.5 mm² and 2.5 mm² are supplied as 50 m (164 ft), 100 m (328 ft), 200 m (656 ft) and 500 m (1640 ft) rings or on disposable drums.

6

System description

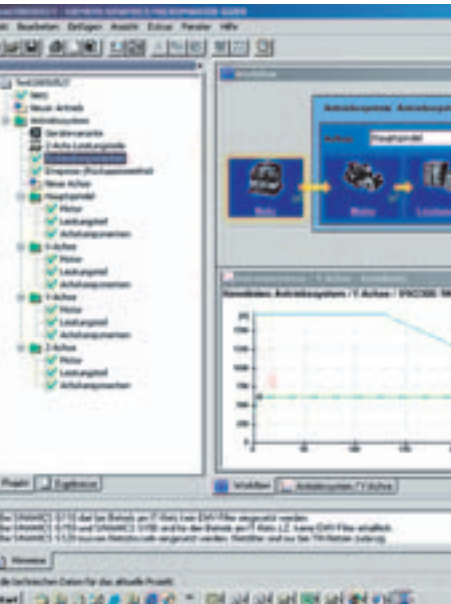

6/2	SIZER configuration tool
6/3	Configuration sequence
6/3	SINAMICS S120 Control Units
6/3	Overview
6/4	Guide to select a closed-loop control variant
6/14	Safety functions
6/14	Overview
6/14	Safety Integrated Functions
6/15	Motors
6/15	Motor selection
6/16	Duty cycles
6/19	Motor types, motor protection, bearing currents, Operation of motors with type of protection "d"
6/20	Power Units
6/20	Overload capability
6/20	Derating characteristic curves
6/22	Selection of the Power Module or Motor Module
6/22	Long motor cables
6/23	Line Modules
6/24	Parallel connection of power units
6/26	Fan control
6/26	System disturbance
6/29	Line-side options
6/30	System Components
6/30	Motor reactors, Sinusoidal filters, Sensor Modules, Expansion Modules, Braking Modules and Braking resistors
6/33	External 24 V DC supply of components
6/34	Mechanical installation of the drive system
6/34	Specification of components for connection system
6/34	Configuration of a drive group in booksize format
6/35	Configuration of a drive group in chassis format
6/35	Configuration of a mixed drive group
6/36	Heat dissipation



Further information

System description

SIZER configuration tool

Overview



The SIZER configuration tool provides an easy-to-use means of configuring the SINAMICS and MICROMASTER 4 drive families, as well as the SINUMERIK solution line CNC control and SIMOTION Motion Control. It provides support when setting up the technologies involved in the hardware and firmware components required for a drive task. SIZER supports the complete configuration of the drive system, from simple individual drives to complex multi-axis applications.

SIZER supports all of the engineering steps in one workflow:

- Selection of the power supply
- Motor design as a result of load configuring
- Calculation of the drive components
- Selecting the required accessories
- Selection of the line-side and motor-side power options

When SIZER was being designed, particular importance was placed on high usability and a universal, function-based approach to the drive task. The extensive user guidance makes using the tool easy. Status information keeps you continually informed of the progress of the configuration process.

The SIZER user interface is available English and in German.

The drive configuration is saved in a project. In the project, the components and functions used are displayed in a hierarchical tree structure.

The project view permits the configuration of drive systems and the copying/inserting/modifying of drives already configured.

The configuration process produces the following results:

- A parts list of the components required
- Technical specifications
- Characteristic curves
- Comments on system reactions
- Location diagram and dimension drawings

These results are displayed in a results tree and can be reused for documentation purposes.

User support is provided by the technological online help menu, which provides the following information:

- Detailed technical data
- Information about the drive systems and their components
- Decision-making criteria for the selection of components

Minimum hardware and software requirements

Programming device or PC with Pentium™ II 400 MHz (Windows™ 2000), Pentium™ III 500 MHz (Windows™ XP)

256 MB RAM (512 MB recommended)

At least 990 MB of free hard disk space

An additional 100 MB of free hard disk space on Windows system drive

Monitor resolution, 1024×768 pixels

Windows™ 2000 SP2, XP Professional SP1, XP Home Edition SP1

Microsoft Internet Explorer 5.5 SP2

Selection and Ordering Data

	Order no.
The SINAMICS MICROMASTER SIZER configuration tool	6SL3070-0AA00-0AG0
English/German	

Overview

General configuration sequence

The function description of the machine provides the basis for the configuration. The definition of the components is based on physical dependencies and is usually carried out as follows:

Step	Description of configuration activity
1	Clarification of type of drive
2	Definition of boundary conditions and integration into automated system
3	Definition of loading case, calculation of max. load torque, definition of motor
4	Definition of the Motor Module
5	Repetition of steps 3 and 4 for additional axes
6	Calculation of the required DC link power and definition of the Line Module
7	Specification of the required control performance and selection of the Control Unit, definition of component cabling
8	Specification of the line-side options (main switch, fuses, line filters, etc.)
9	Definition of additional system components
10	Calculation of the current requirement for the 24 V DC supply for the components and specification of power supplies (SITOP devices, Control Supply Modules)
11	Specification of components for connection system
12	Configuration of drive group components
13	Required cable cross sections for power supply and motor connections
14	Mandatory installation clearances

Configuration begins with the mechanical interface to the machine. A suitable motor is selected according to the specified torques and speeds. A matching power unit is then also chosen. Depending on the requirements of the machine, the motor is supplied as a single drive via a Power Module or within a multi-motor drive group via a Motor Module. Once the basic components have been defined, the system components for matching to the electrical and mechanical interfaces are selected.

The SIZER configuring tool helps the user to select the correct components quickly and easily. The user enters the relevant torque and speed characteristics and SIZER then guides him confidently through the configuring process, identifying suitable motors and matching SINAMICS power units and other system components.

The following sections describe those SINAMICS S120 components which are needed to create a drive system subject to certain boundary conditions. For information about individual components, please refer to the online help in the SIZER configuring tool system.

SINAMICS S120 Control Units

Overview

Basic technological tasks can be carried out by the SINAMICS S120 Control Units. The CU320 Control Unit is available for multi-axis applications and the CU310 Control Unit for single drives.

Sophisticated motion control tasks are best supported by the more powerful SIMOTION D Control Units (D425, D435 and D445) which are performance-graded.

Each of these Control Units is based on an object-oriented SINAMICS S120 standard firmware which contains all the most popular V/f control modes and closed-loop control variants, that can be scaled to meet even the most advanced performance requirements of servo and vector.

The following are ready-to-configure drive objects (drive controls):

- the control of a line module: "Infeed Control"
- the control for the broad scope of robust asynchronous motors (induction motors): "Vector Control"
- the control for permanent-field synchronous motors with demanding dynamic requirements: "Servo Control"

The most commonly used V/f control modes are stored in the "Vector Control" drive object and are ideal for implementing even simple applications such as, for example, group drives with SIEMOSYN motors.

Further information

System description

SINAMICS S120 Control Units

Configuration

Guide to selecting a closed-loop control variant

The two tables below titled "Performance characteristics" and "Closed-loop control characteristics" are provided to help users select the "right" type of closed-loop control.

Performance characteristics: SINAMICS S120 CU310/CU320 Control Units

Characteristics	Servo Control	Vector Control	V/f Control	Notes
Typical application	<ul style="list-style-type: none"> • Drives with highly dynamic motion control • Angular-locked synchronism with isochronous PROFIBUS • For use in machine tools and clocked production machines 	<ul style="list-style-type: none"> • Speed-controlled drives with high speed and torque stability in general mechanical engineering systems • Particularly suitable for asynchronous motors (induction motors) 	<ul style="list-style-type: none"> • Drives with low requirements on dynamic response and accuracy • Highly synchronized group drives, e.g. on textile machines with SIEMOSYN motors 	Mixed operation with V/f control modes is possible. It is for this reason that the V/f control modes are stored only once in the Vector drive object. The V/f characteristic stored in the Servo drive object is provided only for diagnostic purposes.
Dynamic response	Very high	High	Low	Highest dynamic response with 1FK7 High Dynamic synchronous motors and Servo control.
Control modes with encoder	Position control/ Speed control/ Torque control	Position control/ Speed control/ Torque control	None	SIMOTION D with Servo control is standard for coordinated motion control, i.e. gearing/camming.
Control modes without encoder	Speed control	Speed control/ torque control	All V/f control modes	With Servo for asynchronous motors (induction motors) only. With V/f control the speed can be kept constant by means of selectable slip compensation.
Asynchronous motor	Yes	Yes	Yes	V/f control (textiles) is recommended for SIEMOSYN motors
Synchronous motor	Yes	No	No	
Torque motor	Yes	Yes	No	
Linear motor	Yes	No	No	
Permissible ratio for motor current and rated current of Motor Module	1:1 to 1:4	1:1.3 to 1:4	1:1 to 1:12	Maximum control quality up to 1:4. Between 1:4 and 1:8 increasing restrictions as regards torque and rotational accuracy. V/f control is recommended for < 1:8.
Maximum number of parallel-connected motors per Motor Module	4	1	Unlimited in theory	With Servo control, identical motors connected in parallel must be asynchronous motors (induction motors). With V/f control, the motors do not need to be identical.
Number of drives which can be computed by one CU320 Control Unit (current controller clock cycle with default setting)	1 Line Module (ALM, SLM, BLM) plus 6 motor axes	1 Line Module (ALM, SLM, BLM) plus 4 motor axes	1 Line Module (ALM, SLM, BLM) plus 8 motor axes	The number of motor axes can decrease where the application requires additional function modules or a better dynamic response. With V/f control, 4 motor axes are possible in mixed operation with Vector or 5 motor axes in mixed operation with Servo.
Setpoint resolution speed/frequency	31 bits, + sign	31 bits, + sign	0.001 Hz	
Setpoint resolution torque	31 bits, + sign	31 bits, + sign	–	

Configuration (continued)

Characteristics	Servo Control	Vector Control	V/f Control	Notes
Default sampling rate/ current controller/ speed controller/ pulse frequency (booksize)	125 μs/125 μs/ 4 kHz	2 motor axes: 250 μs/1000 μs/ 4 kHz 4 motor axes: 400 μs/1600 μs/ 2.5 kHz	4 motor axes: 250 μs/4 kHz 6 motor axes: 400 μs/2.5 kHz 8 motor axes: 500 μs/ 4 kHz	The sampling rate has a decisive influence on the dynamic response of the control system. When "Isochronous PROFIBUS" is selected, controller cycles 125 μs, 250 μs, 375 μs and 500 μs are adapted automatically.
Default sampling rate current controller/ speed controller/ pulse frequency (chassis frame sizes FX and GX)	250 μs/250 μs/2 kHz	250 μs/ 1000 μs/2 kHz	4 motor axes: 250 μs/ 2 kHz 6 motor axes: 400 μs/ 1.25 kHz 8 motor axes: 500 μs/ 2 kHz	
Default sampling rate/ current controller/ speed controller/ pulse frequency (chassis frame sizes HX and JX and 690 V all frame sizes)		400 μs/ 1600 μs/1.25 kHz	6 motor axes: 400 μs/1.25 kHz	
Maximum output frequency with current controller clock cycle/ pulse frequency (booksize)	650 Hz with 125 μs/ 4 kHz	300 Hz with 250 μs/ 4 kHz	400 Hz with 250 μs/ 4 kHz	Note limit voltage (2 kV) and use of VPM Module with synchronous motors.
Maximum output frequency with current controller clock cycle/ pulse frequency (chassis frame sizes FX and GX)	300 Hz with 250 μs/ 2 kHz	160 Hz with 250 μs/ 2 kHz	200 Hz with 250 μs/ 2 kHz	
Maximum output frequency with current controller clock cycle/ pulse frequency (chassis frame sizes HX and JX)		100 Hz with 400 μs/ 1.25 kHz	100 Hz with 400 μs/ 1.25 kHz	
Maximum field weakening with asynchronous motors (induction motors)	5 times	5 times	5 times	With Servo control combined with encoder and appropriate special motors, field weakening up to 16 times the field-weakening threshold speed is possible.
Maximum field weakening with synchronous motors	2 times 4 times with VPM	2 times	–	These values refer to 1FK7/1FT6 synchronous motors. Note limit voltage (kE factor) with non-Siemens motors.

Closed-loop control characteristics: SINAMICS S120 CU310/CU320 Control Units

Criteria for assessing control quality	Explanations, definitions
Rise time	The rise time is the period which elapses between an abrupt change in a setpoint and the moment the actual value first reaches the tolerance band (2%) around the setpoint. The dead time is the period which elapses between the abrupt change in the setpoint and the moment the actual value begins to increase. The dead time is partially determined by the read-in, processing and output cycles of the digital closed-loop control. Where the dead time constitutes a significant proportion of the rise time, it must be separately identified.
Characteristic angular frequency -3 dB	The limit frequency is a measure of the dynamic response of a closed-loop control. A pure sinusoidal setpoint is input to calculate the limit frequency; no part of the control loop must reach the limit. The actual value is measured under steady-state conditions and the ratio between the amplitudes of actual value and setpoint is recorded. "-3-dB limit frequency": Frequency at which the absolute value of the actual value drops by 3 dB (to 71%) for the first time. The closed-loop control can manage frequencies up to this value and remain stable.
Ripple	The ripple is the undesirable characteristic of the actual value which is superimposed on the mean value (useful signal). Oscillating torque is another term used in relation to torque. Typical oscillating torques are caused by motor slot grids, by limited encoder resolution or by the limited resolution of the voltage control of the IGBT power unit. The torque ripple is also reflected in the speed ripple as being indirectly proportional to the mass inertia of the drive. The ripple is also a measure of "differential" accuracy and therefore also primarily defines the dynamic response to disturbances of the control system.
Accuracy	Accuracy is a measure of the magnitude of the average, repeatable deviation between the actual value and setpoint under nominal conditions. Deviations between the actual value and setpoint are caused by internal inaccuracies in the measuring and control systems. External disturbances, such as temperature or speed, are not included in the accuracy assessment. The closed-loop and open-loop controls should be optimized with respect to the relevant variable.

Further information

System description

SINAMICS S120 Control Units

Configuration (continued)

Basic closed-loop control characteristics of CU320 Control Unit

- Booksize format, pulse frequency 4 kHz, closed-loop torque control

	Servo control		Vector control		Notes
Synchronous motor	1FK7 with resolver	1FT6 with absolute encoder 2048 pulses/revolution	Vector control is not designed as an operating mode for 1FK7/1FT6 synchronous motors.		
Controller cycle	125 μs	125 μs			
Total rise time (rise time + dead time)	1.7 ms (0.7 + 1)	1.5 ms (0.5 + 1)			With speed operating range of 50 rpm and above for resolver. A dead time of 1 ms is the default setting for PROFIBUS DP.
Characteristic angular frequency -3 dB	650 Hz	900 Hz			In this case, the dynamic response is determined primarily by the encoder system.
Torque ripple	3% of M_0	0.6% of M_0			With speed operating range of 20 rpm up to rated speed. A ripple of < 1% is possible with an absolute encoder ≤ 1 rpm. Not possible with resolver.
Torque accuracy	± 1.5% of M_0	± 1.5% of M_0			Measured value averaged over 3 s. With motor identification and friction compensation. In torque operating range up to ± M_0 . Speed operating range 1:10 up to rated speed. Caution: External influences such as motor temperature can cause an additional long-time inaccuracy (constancy) of about ± 2.5%. Approx. ± 1% less accuracy in field-weakening range.
Asynchronous motor (induction motors)	1PH7/1PL6 without encoder	1PH7/1PL6 with incremental encoder 1024 pulses/revolution	1PH7/1PL6 without encoder	1PH7/1PL6 with incremental encoder 1024 pulses/revolution	
Controller cycle	125 μs	125 μs	250 μs	250 μs	
Total rise time (rise time + dead time)	–	1.8 ms (0.8 + 1)	3 ms (2 + 1)	2.2 ms (1.2 + 1)	With encoderless operation in speed operating range 1:10, with encoder 50 rpm and above up to rated speed. A dead time of 1 ms is the default setting for PROFIBUS DP.
Characteristic angular frequency -3 dB	–	600 Hz	250 Hz	400 Hz	With encoderless operation in speed operating range 1:10. The dynamic response is enhanced by an encoder feedback.
Torque ripple	–	1.5% of M_{rated}	2% of M_{rated}	2% of M_{rated}	With encoderless operation in speed operating range 1:20, with encoder 20 rpm and above up to rated speed.
Torque accuracy	–	± 3.5% of M_{rated}	± 2% of M_{rated}	± 1.5% of M_{rated}	Measured value averaged over 3 s. With motor identification and friction compensation, temperature effects compensated by KTY84 and mass model. In torque operating range up to ± M_{rated} . Approx. additional inaccuracy of ± 2.5% in field-weakening range. Servo: Speed operating range 1:10 referred to rated speed. Vector: Speed operating range 1:50 referred to rated speed.

Configuration (continued)

- Booksize format, pulse frequency 4 kHz, closed-loop speed control

	Servo control		Vector control		Notes
Synchronous motor	1FK7 with resolver	1FT6 with absolute encoder 2048 pulses/revolution	Vector control is not designed as an operating mode for 1FK7/1FT6 synchronous motors.		
Controller cycle	125 µs	125 µs			
Total rise time (rise time + dead time)	4.5 ms (3.5 + 1)	3.3 ms (2.3 + 1)			With encoderless operation in speed operating range 1:10, with encoder 50 rpm and above up to rated speed. A dead time of 1 ms is the default setting for PROFIBUS DP.
Characteristic angular frequency -3 dB	140 Hz	250 Hz			In this case, the dynamic response is determined primarily by the encoder system.
Speed ripple	See note	See note			Determined primarily by the total mass moment of inertia, the torque ripple and especially the mechanical configuration. It is not therefore possible to specify a generally applicable value.
Speed accuracy	≤ 0.001% of n_{rated}	≤ 0.001% of n_{rated}			Determined primarily by the resolution of the control deviation and encoder evaluation in the converter. This is implemented on a 32-bit basis for SINAMICS.
Asynchronous motor (induction motors)	1PH7/1PL6 without encoder	1PH7/1PL6 with incremental encoder 1024 pulses/revolution	1PH7/1PL6 without encoder	1PH7/1PL6 with incremental encoder 1024 pulses/revolution	
Controller cycle	125 µs	125 µs	250 µs	250 µs	
Total rise time (rise time + dead time)	13 ms (12 + 1)	5 ms (4 + 1)	12 ms (11 + 1)	8 ms (7 + 1)	With encoderless operation in speed operating range 1:10, with encoder 50 rpm and above up to rated speed. A dead time of 1 ms is the default setting for PROFIBUS DP.
Characteristic angular frequency -3 dB	40 Hz	120 Hz	50 Hz	80 Hz	With encoderless operation in speed operating range 1:10. The dynamic response is enhanced by an encoder feedback. Servo with encoder is slightly more favorable than Vector with encoder, as the speed controller cycle with Servo is quicker.
Speed ripple	See note	See note	See note	See note	Determined primarily by the total mass moment of inertia, the torque ripple and especially the mechanical configuration. It is not therefore possible to specify a generally applicable value.
Speed accuracy	$0.1 \times f_{slip}$	≤ 0.001% of n_{rated}	$0.05 \times f_{slip}$	≤ 0.001% of n_{rated}	Without encoder: Determined primarily by the accuracy of the calculation model for the torque-producing current and rated slip of the asynchronous motor (induction motors) (see table "Typical slip values"). With speed operating range 1: 50 (Vector) or 1:10 (Servo) and with active temperature evaluation.

Further information

System description

SINAMICS S120 Control Units

Configuration (continued)

- Chassis format, pulse frequency 2 kHz, closed-loop torque control

	Servo control		Vector control		Notes
Synchronous motor	1FT6 Big Servo without encoder	1FT6 Big Servo with absolute encoder 2048 pulses/revolution	Vector control is not designed as an operating mode for 1FT6 synchronous motors.		
Controller cycle	250 μs	250 μs			
Total rise time (rise time + dead time)	–	2.2 ms (1.2 + 1)			A dead time of 1 ms is the default setting for PROFIBUS DP.
Characteristic angular frequency –3 dB	–	400 Hz			In this case, the dynamic response is determined primarily by the encoder system.
Torque ripple	–	1.3% of M_0			A ripple of < 1% is possible with an absolute encoder ≤ 1 rpm. Not possible with resolver.
Torque accuracy	–	± 1.5% of M_0			Measured value averaged over 3 s. With motor identification and friction compensation. In torque operating range up to ± M_0 . Speed operating range 1:10 up to rated speed. Caution: External influences such as motor temperature can cause an additional long-time inaccuracy (constancy) of about ± 2.5%. Approx. ± 1% less accuracy in field-weakening range.
Asynchronous motor (induction motors)	1PH7/1PL6 without encoder	1PH7/1PL6 with incremental encoder 1024 pulses/revolution	1PH7/1PL6 without encoder	1PH7/1PL6 with incremental encoder 1024 pulses/revolution	
Controller cycle	250 μs	250 μs	250 μs	250 μs	
Total rise time (rise time + dead time)	–	2.6 ms (1.6 + 1)	3.5 ms (2.5 + 1)	2.6 ms (1.6 + 1)	With encoderless operation in speed operating range 1:10, with encoder 50 rpm and above up to rated speed. A dead time of 1 ms is the default setting for PROFIBUS DP.
Characteristic angular frequency –3 dB	–	350 Hz	200 Hz	300 Hz	With encoderless operation in speed operating range 1:10. The dynamic response is enhanced by an encoder feedback.
Torque ripple	–	2% of M_{rated}	2.5% of M_{rated}	2% of M_{rated}	With encoderless operation in speed operating range 1:20, with encoder 20 rpm and above up to rated speed.
Torque accuracy	–	± 3.5% of M_{rated}	± 2% of M_{rated}	± 1.5% of M_{rated}	Measured value averaged over 3 s. With motor identification and friction compensation, temperature effects compensated by KTY84 and mass model. In torque operating range up to ± M_{rated} . Approx. additional inaccuracy of ± 2.5% in field-weakening range. Servo: Speed operating range 1:10 referred to rated speed. Vector: Speed operating range 1:50 referred to rated speed.

Configuration (continued)

- Chassis format, pulse frequency 2 kHz, closed-loop speed control

	Servo control		Vector control		Notes
Synchronous motor	1FT6 Big Servo without encoder	1FT6 Big Servo with absolute encoder 2048 pulses/revolution	Vector control is not designed as an operating mode for 1FT6 synchronous motors.		
Controller cycle	250 μs	250 μs			
Total rise time (rise time + dead time)	–	6 ms (5 + 1)			With encoderless operation in speed operating range 1:10, with encoder 50 rpm and above up to rated speed. A dead time of 1 ms is the default setting for PROFIBUS DP.
Characteristic angular frequency –3 dB	–	100 Hz			In this case, the dynamic response is determined primarily by the encoder system.
Speed ripple	–	See note			Determined primarily by the total mass moment of inertia, the torque ripple and especially the mechanical configuration. It is not therefore possible to specify a generally applicable value.
Speed accuracy	–	≤ 0.001% of n_{rated}			Determined primarily by the resolution of the control deviation and encoder evaluation in the converter. This is implemented on a 32-bit basis for SINAMICS.
Asynchronous motor (induction motors)	1PH7/1PL6 without encoder	1PH7/1PL6 with incremental encoder 1024 pulses/revolution	1PH7/1PL6 without encoder	1PH7/1PL6 with incremental encoder 1024 pulses/revolution	
Controller cycle	250 μs	250 μs	250 μs	250 μs	
Total rise time (rise time + dead time)	21 ms (20 + 1)	8 ms (7 + 1)	14 ms (13 + 1)	12 ms (10 + 1)	With encoderless operation in speed operating range 1:10, with encoder 50 rpm and above up to rated speed. A dead time of 1 ms is the default setting for PROFIBUS DP.
Characteristic angular frequency –3 dB	25 Hz	80 Hz	35 Hz	60 Hz	With encoderless operation in speed operating range 1:10. The dynamic response is enhanced by an encoder feedback. Servo with encoder is slightly more favorable than Vector with encoder, as the speed controller cycle with Servo is quicker.
Speed ripple	See note	See note	See note	See note	Determined primarily by the total mass moment of inertia, the torque ripple and especially the mechanical configuration. It is not therefore possible to specify a generally applicable value.
Speed accuracy	$0.1 \times f_{slip}$	≤ 0.001% of n_{rated}	$0.05 \times f_{slip}$	≤ 0.001% of n_{rated}	Without encoder: Determined primarily by the accuracy of the calculation model for the torque-producing current and rated slip of the asynchronous motor (induction motors) (see table "Typical slip values"). With speed operating range 1: 50 (Vector) or 1:10 (Servo) and with active temperature evaluation.

Further information

System description

SINAMICS S120 Control Units

Configuration (continued)

Typical slip values for standard asynchronous motors (induction motors)

Motor output	Slip values	Notes
< 1 kW (1.34 HP)	6% of n_{rated} e.g. motor with 1500 rpm: 90 rpm	The slip values of 1PH7 motors are very similar to those of standard motors
< 10 kW (13.41 HP)	3% of n_{rated} e.g. motor with 1500 rpm: 45 rpm	
< 30 kW (40.23 HP)	2% of n_{rated} e.g. motor with 1500 rpm: 30 rpm	
< 100 kW (134.10 HP)	1% of n_{rated} e.g. motor with 1500 rpm: 15 rpm	
> 500 kW (670.50 HP)	0.5% of n_{rated} e.g. motor with 1500 rpm: 7.5 rpm	

Computing performance: Scaling

The performance of the CU320 Control Unit can be scaled by means of firmware. The use of Performance expansion 1 increases computing power by 100%.

The performance requirement is dependent on the scope of functions and control dynamic response demanded by the application and, above all, by the number of drives to be operated on one Control Unit. Performance expansion 1 will be required for capacity utilization of 55% or higher.

The following "scaling table" for the CU320 Control Unit provides a rough overview of computing performance as a function of current controller clock cycle (dynamic response) and number of axes with basic scope of functions (factory setting).

If a CUA31 Control Unit adapter is connected to the CU320, the number of axes is reduced by one in each case.

Note:

- When the easy positioning function module (EPOS) is activated, the axes count of the CU320 is reduced.
- The Sizer configuring tool is needed to calculate the exact performance requirement.

Overview of performance scale for CU320 Control Unit

	Dynamic response (current controller clock cycle)	Number of axes without performance expansion 1	Number of axes with performance expansion 1	Note
Servo control	125 μ s	3	6	Plus one infeed (BLM, SLM, ALM). Number of axes applies only to basic functionality. Without expanded setpoint channel. Note power unit derating where applicable.
	250 μ s	3	6	
Vector control	250 μ s	1	2	Plus one infeed (BLM, SLM, ALM). Number of axes applies only to basic functionality. Expanded setpoint channel included as standard. Note power unit derating where applicable.
	400 μ s	2	4	
V/f control	250 μ s	2	4	Plus one infeed (BLM, SLM, ALM). Number of axes applies only to basic functionality. Expanded setpoint channel included as standard. Values for chassis units in brackets.
	400 μ s	3	6	
	500 μ s	4	8	
Mixed operation				
Servo control plus V/f control	125 μ s + 250 μ s/400 μ s	–	5	Maximum 2 V/f axes with 250 μ s current controller clock cycle, otherwise divide as required.
Vector control plus V/f control	250 μ s/400 μ s	1/2	2/4	In mixed Vector-with-V/f operation, no difference to pure Vector operation.

Configuration (continued)

Influencing variables on minimum required pulse frequency of power unit

Basic requirements such as maximum speed or necessary dynamic response of the control have a direct effect in determining the minimum pulse frequency of the power unit. If the minimum pulse frequency exceeds the rated pulse frequency, derating must be implemented accordingly (see power unit description).

The following table provides a general overview.

Influencing variables		Minimum pulse frequency	Notes
Servo control, Vector control (required max. output frequency/speed)	100 Hz correspond to: 3000 rpm for $Z_p = 2$ 1500 rpm for $Z_p = 4$ 428 rpm for $Z_p = 14$ 352 rpm for $Z_p = 17$	1.25 kHz	Z_p is the number of pole pairs of the motor. This equals 2 on 1PH7 asynchronous motors (induction motors). 1FK7/1FT6 synchronous motors have between 2 and 4 pairs of poles. Torque motors in shaft height < 200 have 14 pairs of poles and in shaft height ≥ 200 17 pairs of poles.
	160 Hz correspond to: 4800 rpm for $Z_p = 2$ 2400 rpm for $Z_p = 4$ 685 rpm for $Z_p = 14$ 565 rpm for $Z_p = 17$	2 kHz	
	200 Hz correspond to: 6000 rpm for $Z_p = 2$ 3000 rpm for $Z_p = 4$ 856 rpm for $Z_p = 14$ 704 rpm for $Z_p = 17$	2.5 kHz	
	300 Hz correspond to: 9000 rpm for $Z_p = 2$ 4500 rpm for $Z_p = 4$ 1284 rpm for $Z_p = 14$ 1056 rpm for $Z_p = 17$	4 kHz	
	400 Hz correspond to: 12000 rpm for $Z_p = 2$ 6000 rpm for $Z_p = 4$	4 kHz	
V/f control (required max. output frequency/speed)	100 Hz correspond to: 6000 rpm for $Z_p = 1$ 3000 rpm for $Z_p = 2$	1.25 kHz	V/f control is designed only for asynchronous (induction motors) and SIEMOSYN motors. Z_p is the number of pole pairs of the motor. This is mainly between 1 and 4 on 1LA/1LG standard asynchronous motors (induction motors). SIEMOSYN motors have 1 or 2 pole pairs or, with larger shaft heights, 3 pairs.
	160 Hz correspond to: 9600 rpm for $Z_p = 1$ 4800 rpm for $Z_p = 2$	2 kHz	
	200 Hz correspond to: 12000 rpm for $Z_p = 1$ 6000 rpm for $Z_p = 2$	2.5 kHz	
	300 Hz correspond to: 18000 rpm for $Z_p = 1$ 9000 rpm for $Z_p = 2$	4 kHz	
	400 Hz correspond to: 24000 rpm for $Z_p = 1$ 12000 rpm for $Z_p = 2$	4 kHz	
Dynamic response requirement (current controller clock cycle)	125 μ s 250 μ s 400 μ s 500 μ s	4 kHz 2 kHz 2.5 kHz 1 kHz	Servo control requires a minimum pulse frequency of 2 kHz.
Sinusoidal filter	–	4 kHz	Caution: If sinusoidal filters are operated at low frequencies, resonance problems can occur and cause the filters to severely overheat.
Output reactor to motor	Max. frequency: 150 Hz correspond to 4500 rpm for $Z_p = 2$		The output reactor can be operated at maximum 2 kHz only.

Further information

System description

SINAMICS S120 Control Units

Configuration (continued)

Core topologies: Component cabling with DRIVE-CLiQ

The components communicate with one another via the standard DRIVE-CLiQ interface.

This interface connects a Control Unit with the power components, encoders and other system components, e.g. Terminal Modules. Setpoints and actual values, control commands, status messages, and rating plate data for the components are transferred via DRIVE-CLiQ.

Basic rules for wiring with DRIVE-CLiQ

The following rules apply to the wiring of components with DRIVE-CLiQ:

- A maximum of 16 nodes can be connected to a DRIVE-CLiQ socket on the CU320 Control Unit
- Up to eight nodes can be connected in a line. A line is always seen from the perspective of the Control Unit
- Maximum 6 Motor Modules in a line
- Ring wiring is not permitted
- Components must not be double-wired
- The motor encoder should be connected to the associated Motor Module.

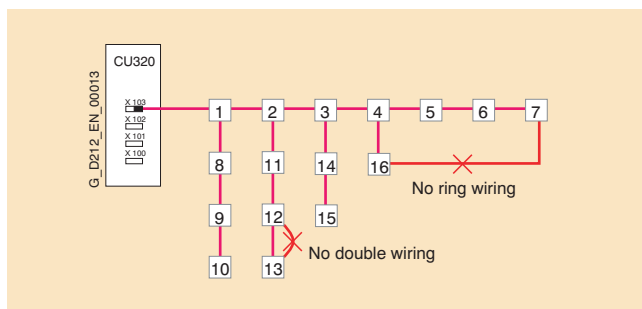

DRIVE-CLiQ configuration examples

Only one current controller clock cycle can be set for modules connected via DRIVE-CLiQ. For this reason, only combinations of modules with the same current controller clock cycle can be operated on a DRIVE-CLiQ connection. To simplify the configuring process, it is advisable to supply the Line Module and Motor Modules via separate DRIVE-CLiQ connections.

The power components are supplied with the required DRIVE-CLiQ connecting cable for connection to the adjacent DRIVE-CLiQ node in the axis grouping (line topology). Pre-assembled DRIVE-CLiQ cables in various lengths up to 100 m (328 ft) are available for connecting motor encoders, direct measuring encoders, Terminal Modules, etc.

The DRIVE-CLiQ cable connections inside the control cabinet must not exceed 70 m (230 ft) in length, e.g. connection between the CU320 Control Unit and the first Motor Module or between Motor Modules. The maximum permissible length of DRIVE-CLiQ MOTION-CONNECT cables to external components is 100 m (328 ft).

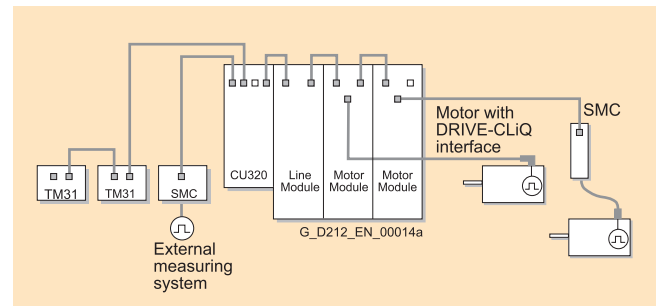

Example of a line topology for standard solutions with Servo Control

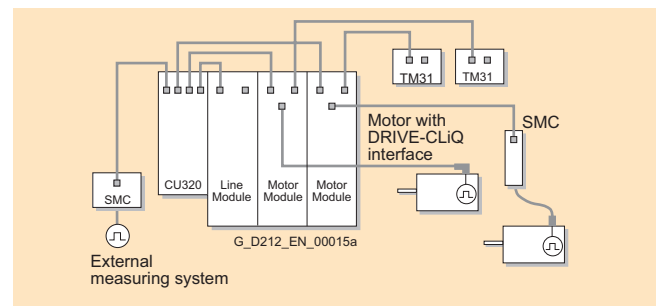

Example of a tree topology for high-performance solutions, e.g. high-dynamic axes in direct motion control group, selective access to individual axes/axis groupings for maintenance operation, etc.

Configuration (continued)

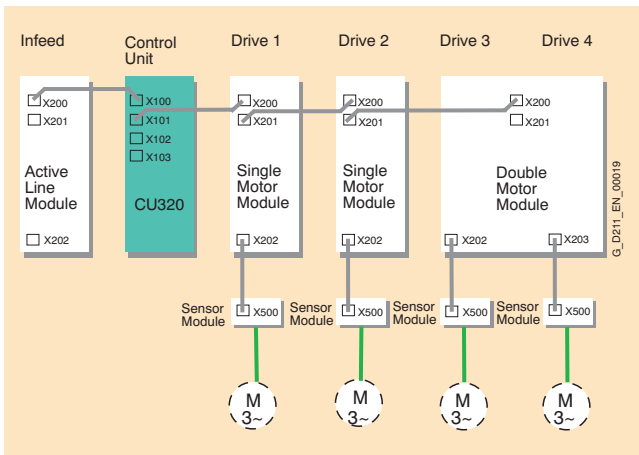

Preferred wiring of DRIVE-CLiQ connections illustrated by example of booksize format
 Active Line Module: Current controller clock cycle 250 μ s
 Motor Modules: 4 \times Vector control = current controller clock cycle 400 μ s

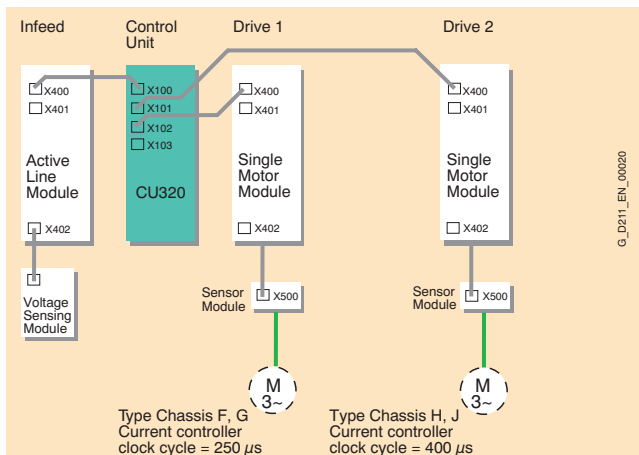

Wiring illustrated by example of chassis format with different current controller clock cycles

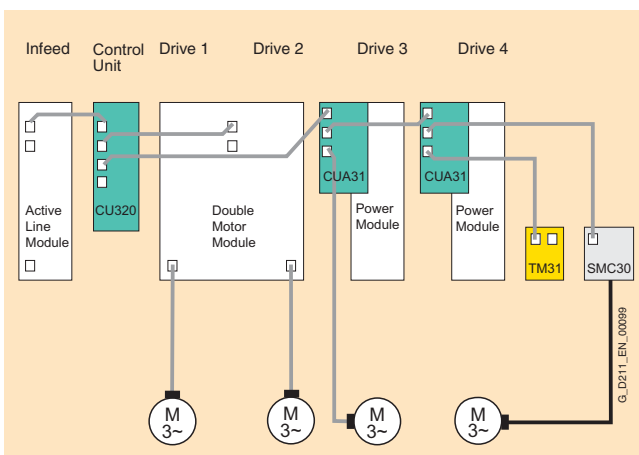

Example of wiring: Power Modules can also be operated on a CU320 when connected via a CUA31

Overview

The "Safety Integrated" functions provide highly-effective application-oriented protection for personnel and machinery. These functions are integrated in the drive; this means that a higher-level controller is not required. The current version of SINAMICS S120 offers the following Safety Integrated functions (terms as defined in draft standard IEC 61800-5-2):

- Safe Torque Off (STO)
- Safe Brake Control (SBC)
- Safe Stop 1 (SS1)

These safety functions are completely integrated in the drive system and use drive-specific interfaces:

- 2 input terminals for selection of the "Safe Torque Off" (STO) function
- 2 output terminals for the "Safe Brake Control" (SBC) function

They are fail-safe and fully electronic and therefore ensure short response times. Error detection is supported by integrated self-tests.

Safe Torque Off

"Safe Torque Off" (STO) – also known as "Safe Standstill" (SH) – is a function that helps prevent the drive from restarting unexpectedly in accordance with EN 60204-1, Section 5.4. "Safe Torque Off" disables the drive pulses and immobilizes the power supply to the motor. The drive is reliably torque-free. This state is monitored internally in the drive. Feedback to a higher-level control or integration of a main contactor are no longer required.

Safe Brake Control

The Safe Brake Control (SBC) function is used to operate holding brakes which are operative at zero current, e.g. motor holding brakes. The brake control circuit is a fail-safe, two-channel design.

The Safe Brake Control function is activated when "Safe Torque Off" is selected and when safety monitors with safe pulse disable are tripped.

Note: "Safe Brake Control" does not detect faults in the brake itself (e.g. worn brake).

Safe Stop 1

The "Safe Stop 1" function can stop the drive in accordance with EN 60204-1, stop category 1. When "Safe Stop 1" is selected, the drive brakes along the OFF3 ramp and automatically activates the "Safe Torque Off"/"Safe Brake Control" function when the parameterized safety delay timer runs down.

Function

The operating principle of Safety Integrated

Two independent switch-off signal paths

Two independent switch-off signal paths are available. All switch-off signal paths are low active, thereby ensuring that the system is always switched to a safe status if a component fails or in the event of cable breakage. If an error is discovered in the switch-off signal paths, the "Safe Torque Off" function is activated and a system restart inhibited.

Two-channel monitoring structure

All the main hardware and software functions for Safety Integrated are implemented in two independent monitoring channels (e.g. switch-off signal paths, data management, data comparison). A cyclic crosswise comparison of the safety-relevant data in the two monitoring channels is carried out.

The monitoring functions in each monitoring channel work on the principle that a defined status must prevail before each action is carried out and a specific acknowledgement made after each action. If these expectations of a monitoring channel are not fulfilled, the drive coasts to a standstill (two channel) and an appropriate message is output.

Forced dormant error detection or testing of the switch-off signal paths

Forced dormant error detection of the switch-off signal paths is used to detect errors in the software/hardware of the two monitoring channels as quickly as possible and is performed automatically when safety functions are activated/deactivated. To fulfill the requirements of EN 954-1 regarding early error detection, the two switch-off signal paths must be tested at least once within a defined time to ensure that they are functioning properly. For this purpose, forced dormant error detection must be triggered manually by the user or automatically. A timer monitors the timing of forced dormant error detection runs.

A forced dormant error detection run must be performed on the switch-off signal paths at least once during the time set in this parameter. Once this time has elapsed, an alarm is output and remains active until forced dormant error detection is carried out.

When the appropriate safety devices are implemented (e.g. protective doors), it can be assumed that running machinery will not pose any risk to personnel. For this reason, only an alarm is output to inform the user that a forced dormant error detection run is due, thereby requesting that this be carried out at the next available opportunity. This alarm does not affect machine operation.

The user must set the time interval for carrying out forced dormant error detection runs to between 0 and 9000 hours depending on the application (factory setting: 8 hours).

Examples of when forced dormant error detection runs are required:

- When the drives are at a standstill after the system has been switched on
- When the protective door is opened
- At defined intervals (e.g. every 8 hours)
- In automatic mode, dependent on time and event.

Configuration

Motor selection

The motor is selected on the basis of the required torque, which is defined by the application, e.g. traveling drives, hoisting drives, test stands, centrifuges, paper and rolling mill drives, feed drives or main spindle drives. Gear units for movement conversion or for adapting the motor speed and motor torque to the load conditions must also be considered.

As well as the load torque, which is determined by the application, the following mechanical data are among those required to calculate the torque to be provided by the motor:

- Masses to be moved
- Diameter of the drive wheel/diameter
- Leadscrew pitch, gear ratios
- Frictional resistance data
- Mechanical efficiency
- Traversing paths
- Maximum velocity
- Maximum acceleration and maximum deceleration
- Cycle time

You must decide whether synchronous or asynchronous motors (induction motors) are to be used.

Synchronous motors should be selected for compact construction volume, low rotor moment of inertia and therefore maximum dynamic response.

In this context, suitable motors would be the 1FT and 1FK, which can operate in "Servo" control mode.

Asynchronous motors (induction motors) can be used to increase maximum speeds in the field-weakening range. Asynchronous motors (induction motors) for higher powers are also available.

In this context, suitable motors would be the 1PL, 1PH, 1LA and 1LG, which can operate in "Vector" control mode.

The following factors are of prime importance during configuration:

- The type of line supply, when using specific types of motor and/or line filters on IT systems (non-grounded systems)
- The ambient temperatures and the installation altitude of the motors and drive components

The motor-specific limiting characteristics provide the basis for defining the motors.

These define the torque or power characteristic over speed and take into account the motor limits based on the DC-link voltage of the Power or Motor Module. The DC-link voltage in turn is dependent on the line voltage and, with multi-motor drives, on the type of Line Module.

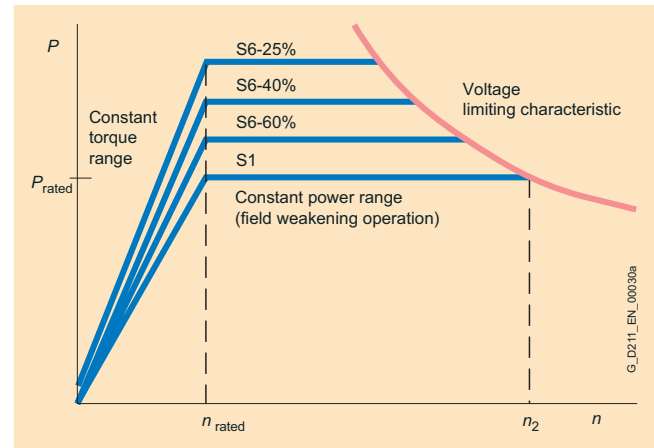

Limiting characteristics for asynchronous motors (induction motors) (example)

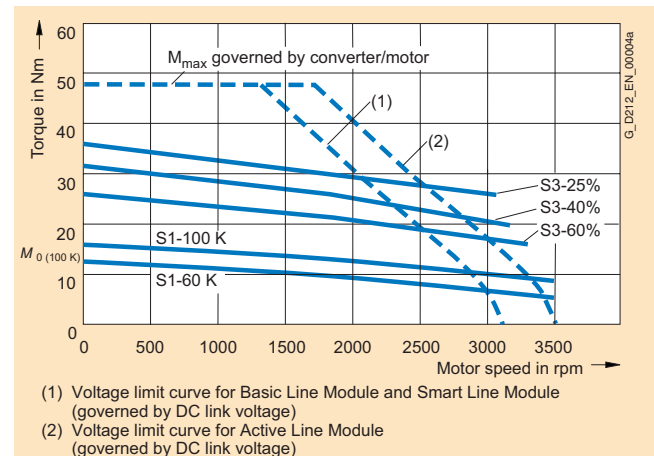

Limiting characteristics for synchronous motors (example)

Further information

System description

Motors

Configuration (continued)

Duty cycles

The motor is defined on the basis of the type of duty prescribed by the application. Different characteristics must be used for different duty requirements. The following operating scenarios have been defined:

- Duty cycles with constant ON duration
- Duty cycles with varying ON duration
- Free duty cycle

The aim is to identify characteristic torque and speed operating points, on the basis of which the suitable motor can be selected for a particular duty cycle.

Once the operating scenario has been defined and specified, the maximum motor torque is calculated. In general, this takes place during the acceleration phase. The load torque and the torque required to accelerate the motor are added together.

The maximum motor torque is then verified with the limiting characteristics of the motors.

The following applies to 1PL and 1PH asynchronous motors (induction motors): Maximum motor torque = $2 \times$ rated torque.

The following criteria must be taken into account when defining the motor:

- The dynamic limits must be observed, i.e. all speed-torque points of the relevant duty cycle must lie below the relevant limiting characteristic.
- The thermal limits must be observed, i.e. for synchronous motors, the effective motor torque at the average motor speed resulting from the duty cycle must lie below the S1 characteristic (continuous duty). For asynchronous motors (induction motors), the rms value of the motor current within a load duty cycle must be less than the rated motor current.
- It should be noted that the maximum permissible motor torque on synchronous motors at higher speeds is reduced as a result of the voltage limiting characteristic. In addition, a margin of 10% below the voltage limiting characteristic should be observed to safeguard against voltage fluctuations.
- When using asynchronous motors (induction motors), the permissible motor torque in the field-weakening range is restricted by the voltage limiting characteristic (stability limit). A margin of 30% should be observed.
- When using an absolute encoder, the rated torque of the motor is reduced by 10% due to the thermal limits of the encoder.

Duty cycles with constant ON duration

Duty cycles with constant ON duration place specific requirements on the torque characteristic as a function of the speed, e.g. $M = \text{constant}$, $M \sim n^2$, $M \sim n$ or $P = \text{constant}$.

These drives typically work at a steady-state operating point. Base load dimensioning is applied. The base load torque must lie below the S1 characteristic.

In the event of transient overloads (e.g. when accelerating) an overload has to be taken into consideration. The peak torque must lie below the voltage limiting characteristic on synchronous motors or below the stability limit on asynchronous motors (induction motors).

In summary, the dimensioning is as follows:

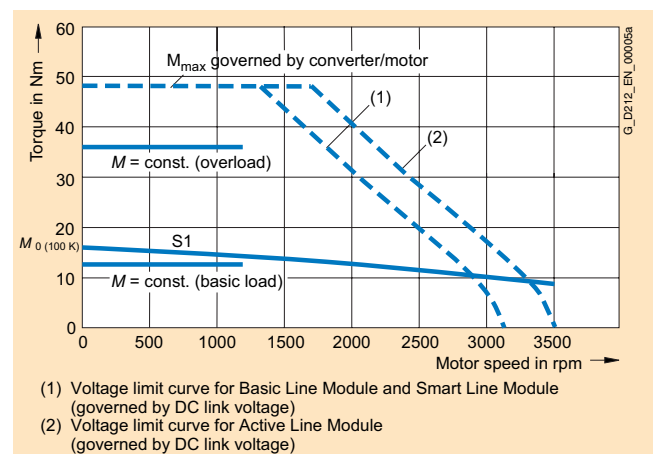

Selection of motors for duty cycles with constant ON duration (example)

Configuration (continued)

Duty cycles with varying ON duration

As well as continuous duty (S1), standardized intermittent duty types (S3) are also defined for duty cycles with varying ON durations. S3 duty is an operation which comprises of a sequence of similar cycles, each of which comprises of a time with constant load and a break.

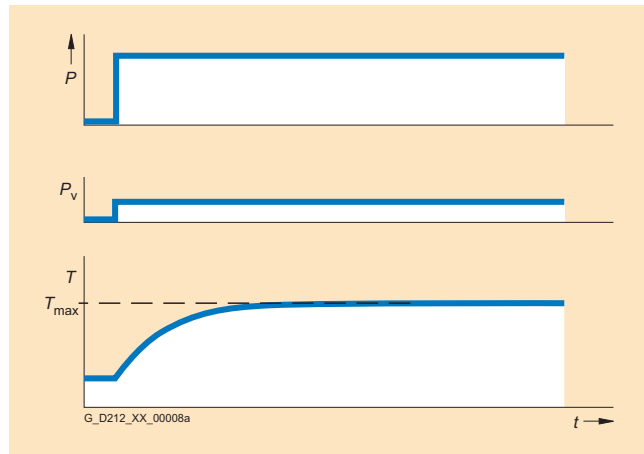

S1 duty (continuous operation)

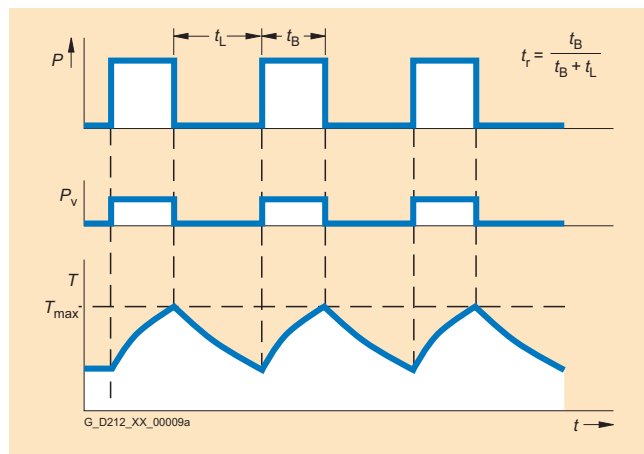

S3 duty (intermittent duty without affecting the starting process)

Fixed variables are usually used for the relative ON duration:

- S3 – 60%
- S3 – 40%
- S3 – 25%

Corresponding motor characteristics are provided for these specifications. The load torque must lie below the corresponding thermal limiting characteristic of the motor. Overload dimensioning is taken into account for duty cycles with varying ON duration.

Free duty cycle

A load duty cycle defines the characteristics of the motor speed and the torque with respect to time.

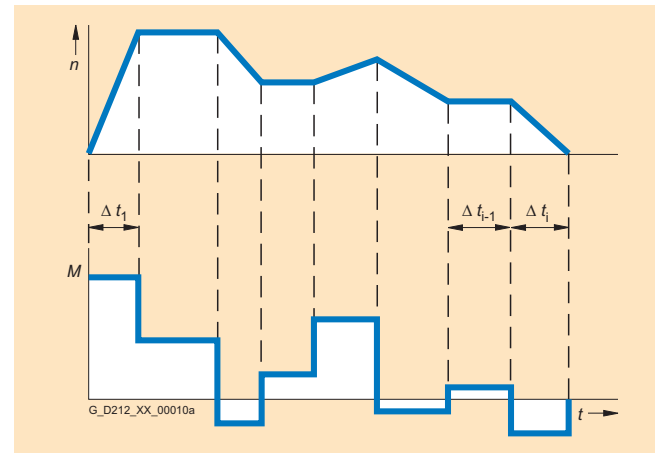

A load torque is set for each time period. In addition to the load torque, the average load moment of inertia and motor moment of inertia must be taken into account for acceleration. A friction torque, which works in opposition to the direction of movement, may be required.

The gear ratio and gear efficiency must be taken into account when calculating the load and/or acceleration torque to be provided by the motor. A higher gear ratio increases positioning accuracy in terms of encoder resolution. At the given motor encoder resolution, as the gear ratio increases, so should the resolution of the machine position to be detected.

For further information about the importance of gearboxes, see the motor descriptions.

The effective torque M_{eff} must lie below the S1 characteristic.

The maximum torque M_{max} is reached during the acceleration process and must lie below the voltage limiting characteristic on synchronous motors and below the stability limit on asynchronous motors (induction motors).

Motor selection

Based on the motor data it is now possible to identify a motor which meets the requirements of the application.

In a second step, a check is made as to whether the thermal limits are maintained. For this purpose, the motor current at base load must be calculated. For configuration based on duty cycle with constant ON duration with overload, the overload current based on the required overload torque must be calculated. The calculation rules for this purpose depend on the type of motor used (synchronous motor, asynchronous motor) (induction motors) and the operating scenario (duty cycles with constant ON duration, duty cycles with varying ON duration, free duty cycle).

Finally, the other characteristics of the motor must be defined. This is done by configuring the motor options (see motor description).

Further information

System description

Motors

Configuration (continued)

Drives with quadratic load torque

Drives with a quadratic load torque ($M \sim n^2$), such as drives for pumps and ventilators, require the full torque at the rated speed. Increased starting torques or high load surges do not usually occur. It is therefore unnecessary to provide a higher overload capability for the Motor Module.

The following applies to selection of a suitable Motor Module for drives with a quadratic load torque: The rated current of the Motor Module must be at least as large as the motor current at full torque in the required load point.

When using standard 1LG and 1LA motors, these motors can also be loaded with the full rated power even in converter mode. They are then utilized according to temperature class F. However, if the motors may only be used according to temperature class B, the motor output must be derated by 10%.

Selection of suitable motors and power units for a specific application is supported by the SIZER configuring tool.

Drives with constant load torque

The 1LG and 1LA self-cooled motors cannot produce their full rated torques throughout the complete speed range in continuous operation. The continuous permissible torque decreases as the speed decreases because of the reduced cooling effect (see diagram).

Depending on the speed range, the torque, and thus the output, must be derated for self-cooled motors.

In the case of 1PL, 1PH and 1PQ forced-ventilated motors, no derating or only relatively minor derating (depending on their speed range) is required.

In the case of frequencies above the rated frequency f_{rated} , the motors are operated in the field-weakening range. The usable torque is reduced in this case by approx. f_{rated}/f , and the output remains constant. Especially in the control modes with V/f characteristic, a sufficient margin of $\geq 30\%$ from the breakdown torque, which decreases as a function of $(f_{rated}/f)^2$, must be provided.

The selected basic load current of the Power Module or Motor Module should be at least as high as the motor current at full torque in the required load point.

Selection of suitable motors and power units for a specific application is supported by the SIZER configuring tool.

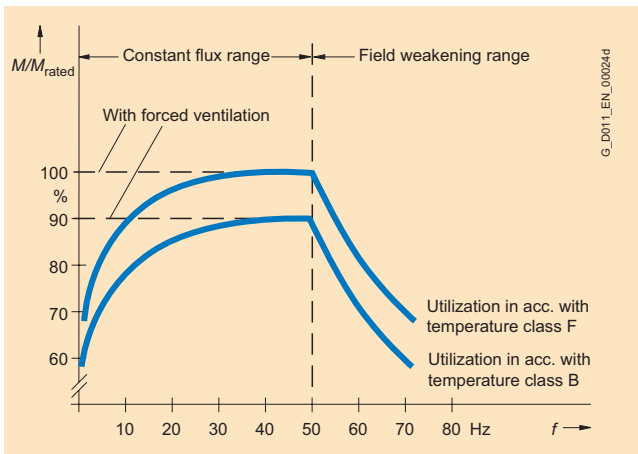

Typical response of the permissible torque with self-cooled motors (e.g. 1LG/1LA) with a rated frequency of 50 Hz

Configuration (continued)

Motor types

1LA and 1LG standard motors are recommended for applications with no special mechanical requirements. With regard to the voltage stress, the standard insulation of the motors is designed such that operation on the converter is possible without limitation at voltages $V \leq 500$ V (corresponding to a DC link voltage of $V_d \leq 720$ V).

1LA8, 1PQ8, 1LG6, 1PH7 and 1PL6 motors with shaft height 280 are also available with a higher winding insulation resistance for converter-fed operation with supply voltages up to a line voltage of 690 V (corresponding to a DC link voltage of $V_d \leq 1035$ V) and do not require a filter.

With the reinforced insulation system, there is less slot space for the same number of winding turns as compared to normal insulation; this means that the rated output of these motors is slightly lower.

For higher torque requirements, self-cooled motors 1LA4 or forced-ventilated motors 1PQ4 (IP55 degree of protection) from the H-compact II series are available for the higher output range.

1PH7 and 1PL6 motors are recommended where a wide speed range and high maximum speeds are required, but mounting space is limited. 1PH7/1PL6 motors with the same rated power are on average 1 to 2 shaft heights smaller than comparable standard asynchronous motors (induction motors).

For more information about motor types 1LA, 1LG and 1PQ8, please refer to Catalog D 81.1.

The full performance capability of the SINAMICS S120 drive system can be utilized when it is combined with 1FT6 and 1FK7 synchronous motors, 1FW3 torque motors and 1PH7, 1PL6 and 1PH4 asynchronous motors (induction motors). The Control Unit evaluates the electronic rating plate and the motor-integrated encoders via the DRIVE-CLiQ interface. This means that motor and encoder data do not need to be parameterized when the system is commissioned or serviced.

The following motor types are available with integrated DRIVE-CLiQ interface:

- 1FT6, 1FK7 synchronous motors
- 1FW3 torque motors
- 1PH7, 1PL6, 1PH4 asynchronous motors (induction motors)

The DRIVE-CLiQ interface is supplied with 24 V DC via the encoder cable.

For further information see three-phase Motors.

Motor protection

The Control Units which control the Power and Motor Modules contain a I^2t detection circuit with which they supply a thermal model for calculating the motor temperature. These units therefore provide a simple, thermal motor protection function which requires no external components.

If necessary, more precise motor protection can be afforded by direct temperature measurement using KTY84 sensors or PTC thermistors in the motor winding.

When using KTY84 sensors, **A23** is the relevant motor option which must be specified when ordering the 1LA8 and 1LG4/1LG6 motors. These sensors are fitted as standard in 1FK, 1FT, 1FW3, 1PH and 1PL motors.

If PTC thermistors are required, the motor option **A11** or **A12** must be specified when ordering the 1LG4/1LG6 motors. With 1LA8/1PQ8 motors, the sensors are fitted as standard.

Bearing currents

In order to apply currents to the motor which are as sinusoidal as possible (smooth running, oscillation torques, stray losses), a high clock frequency is required for the output voltage. The steep voltage pulses generated at this frequency cause charge/discharge currents in the motor winding capacitance, which in turn generate circular magnetic flux in the motor. This physical effect is particularly evident with larger motors. As a result, the circuit can close via the two motor bearings, resulting in dangerous bearing currents. To eliminate the risk of these so-called circular currents, it is advisable to insulate the bearings at the NDE on converter-fed motors.

The insulated bearing is standard for all 1LA8 motors which are designated for converter operation.

With the 1LG4/1LG6 motors of size 280 and above, an insulated bearing at the NDE is available as an option (order code **L27**). With the 1PH7 and 1PL6 motors of size 180 and above, an insulated bearing at the NDE is available as an option (order code **L27**).

Grounding deficiencies can cause rotor ground currents to flow from the motor shaft to the connected load. To prevent this type of bearing current, it is essential to ground the motor casing effectively, e.g. by means of a shielded motor cable. The motor housing and the housing of the Power Module or Motor Module must be coupled with the lowest possible resistance for the high-frequency charge/discharge currents.

For this purpose, it is advisable to use a symmetrical, shielded three-core motor cable in which the PE conductor is arranged symmetrically around the conductors.

Motor reactors are also a suitable means of reducing the types of bearing current described above.

The motors must be mounted in the machine in such a way that no axial forces can act on the motor shaft and that vibration transfer to the shaft is eliminated as far as possible.

Operation of motors with type of protection "d"

Siemens 1MJ asynchronous motors can be connected as explosion-proof motors with "flameproof enclosure" Eex de IIC both to the mains supply and to Power Modules or Motor Modules.

In accordance with the test directives, 1MJ motors must be equipped with PTC thermistors.

If 1MJ motors are connected to Power Modules or Motor Modules, their maximum permissible torque must be reduced and according to the load characteristic, when utilized according to temperature class B; this also applies to the 1LA motors of the same output.

1MJ motors have a terminal box with "increased safety" EEx e II as standard.

For further information about these motors, please refer to Catalog D 81.1.

Configuration (continued)

Overload capability

The power units of the Line Modules, Motor Modules and Power Modules are designed for brief overloads, i.e. the Modules are capable of supplying more than the rated current I_{rated} for short periods. In this instance, the thermal storage capacity of the heat sink is utilized, allowing for the relevant thermal time constants. The power semiconductors and actual current sensing circuit are rated for a maximum current I_{max} which must not be exceeded. The overload capability is determined by I_{max} , I_{rated} and the thermal time constants. A number of characteristic duty cycles are specified in the technical data for the power units. The SIZER configuring tool calculates the load on the basis of a specified duty cycle with optional time characteristic and then identifies the power unit which is required.

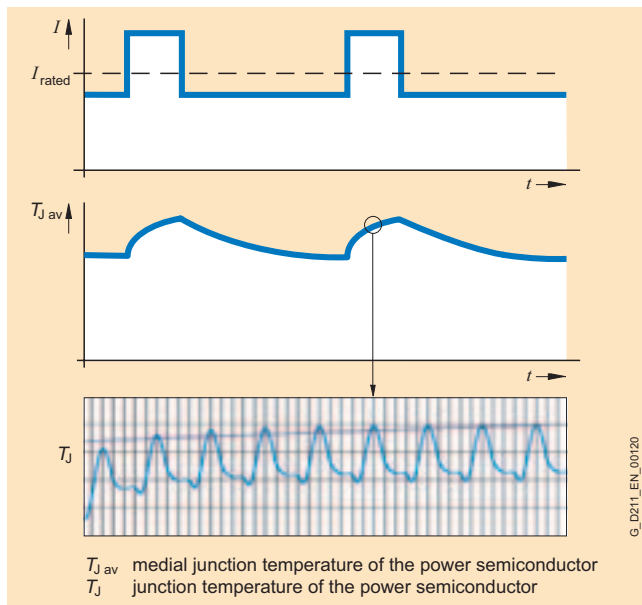

Derating characteristic curves

The power units can be operated with rated current or power and the specified pulse frequency up to an ambient temperature of 40 °C (104°F). The heat sink reaches the maximum permissible temperature at this operating point. If the ambient temperature increases above 40 °C (104°F), the resulting heat loss must be reduced to prevent the heat sink from overheating.

At a given current, the heat loss increases in proportion to the pulse frequency. The rated output current I_{rated} must be reduced to ensure that the maximum heat loss or heat sink temperature for higher pulse frequencies is not exceeded. When the correction factor k_f for the pulse frequency is applied, the rated output current I_{ratedf} that is valid for the selected pulse frequency is adjusted.

When configuring a drive, please note that power units may not be capable of supplying the full current or power in the temperature range between 40 °C (104°F) and 55 °C (131°F). The power units measure the heat sink temperature and protect themselves against thermal overloading at temperatures > 40 °C (104°F).

The air pressure, and therefore air density, drop at altitudes above sea level. At these altitudes, the same quantity of air does not have the same cooling effect and the air gap between two electrical conductors can only insulate a lower voltage. Typical air pressure values are:

- 0 m above sea level: 100 kPa
- 2000 m (6562 ft) above sea level: 80 kPa
- 3000 m (9843 ft) above sea level: 70 kPa
- 4000 m (13124 ft) above sea level: 62 kPa
- 5000 m (16405 ft) above sea level: 54 kPa

At installation altitudes above 2000 m (6562 ft), the line voltage must not exceed certain limits to ensure that surge voltages can be insulated in accordance with EN 60664-1 for surge voltage category III. If the line voltage is higher than this limit at installation altitudes > 2000 m (6562 ft), measures must be taken to reduce transient category III surge voltages to category II values, e.g. equipment must be supplied via an isolating transformer.

In order to calculate the permissible output current or power, the derating factors must be multiplied for the effects described above. The derating factor k_I for current as a function of installation altitude can be offset against the derating factor k_T for ambient temperature. If the result of multiplying derating factor k_T by derating factor k_I is greater than 1, then the calculation must be based on a rated current of I_{rated} or I_{ratedf} . If the result is < 1, then it must be multiplied by the rated current I_{rated} or I_{ratedf} to calculate the maximum permissible continuous current. The derating factor $k = k_f \times k_T \times k_I$ calculated by this method to obtain the total derating value must be applied to all current values in the specified duty cycles I_{rated} , I_H , I_L .

The derating characteristics of Power Modules, Line Modules and Motor Modules can be found in the technical data of the relevant Module (see component descriptions).

Configuration (continued)

Examples of derating characteristic curves and calculation of the permissible output current:

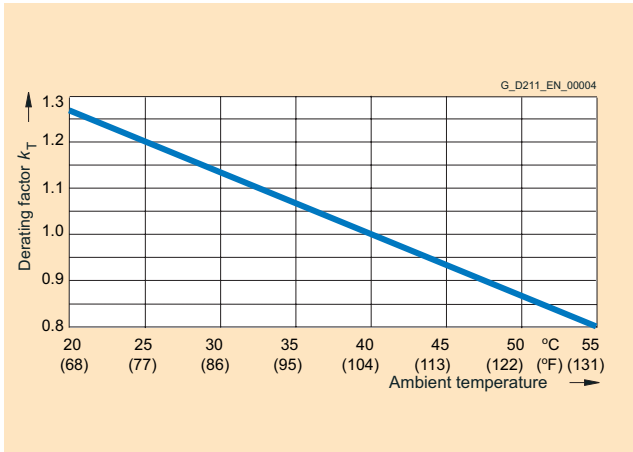

Current derating as a function of the ambient temperature

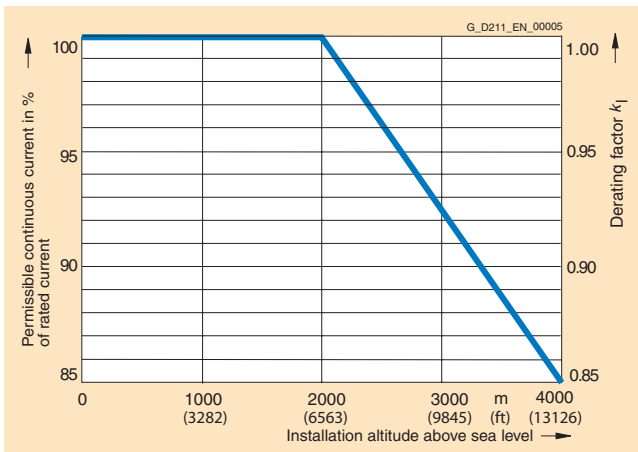

Current derating as a function of the installation altitude

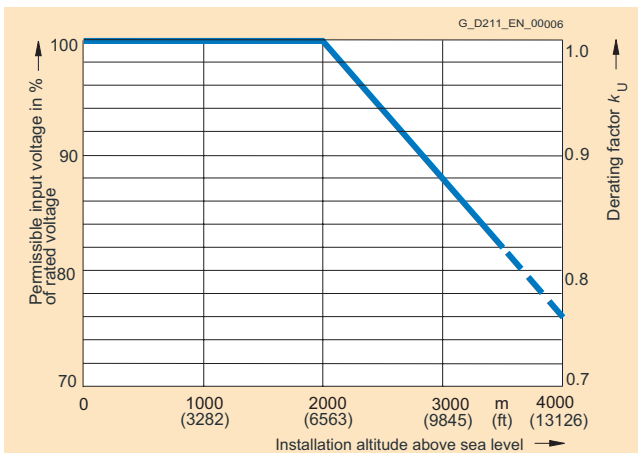

Voltage derating as a function of the installation altitude

Example 1

A drive system is to be operated at an altitude of 2500 m (8202.5 ft) at a maximum ambient temperature of 30 °C (86 °F) and rated pulse frequency.

Since the ambient temperature is below 40 °C (104°F), a compensation calculation (installation altitude/ambient temperature) can be applied.

Installation altitude 2500 m (8202.5 ft): Derating factor $k_I = 0.965$, $k_U = 0.94$

Max. ambient temperature 30 °C (86°F): Derating factor $k_T = 1.133$

$k_I \times k_T = 0.965 \times 1.133 = 1.093 \Rightarrow 1.0$ due to installation altitude/ambient temperature compensation

$k = k_f \times (k_I \times k_T) = 1.0 \times (1.0) = 1.0$

Result: Current derating is not required.

However, IEC 60664-1 stipulates that voltage derating is required.

The units in voltage range 380 V to 480 V can be operated up to a voltage of $480 \text{ V} \times 0.94 = 451 \text{ V}$, and the units in voltage range 660 V to 690 V up to $690 \text{ V} \times 0.94 = 648 \text{ V}$.

Example 2

When a drive group is configured, a Motor Module with the order number 6SL3320-1TE32-1AA0 is selected (rated output current 210 A, base load current for high overload 178 A). The drive group is to be operated at an altitude of 3000 m (9843 ft) where ambient temperatures could reach 35 °C (95 °F) as a result of the installation conditions. The pulse frequency must be set to 4 kHz to provide the required dynamic response.

Installation altitude 3000 m (9843 ft): Derating factor $k_I = 0.925$, $k_U = 0.88$

Max. ambient temperature 35 °C (95°F): Derating factor $k_T = 1.066$

$k_I \times k_T = 0.925 \times 1.066 = 0.987 \Rightarrow$ not fully compensated by installation altitude/ambient temperature

$k = k_f \times (k_I \times k_T) = 0.82 \times (0.925 \times 1.066) = 0.809$

Result: Current derating is required.

Where these boundary conditions apply,

- the max. permissible continuous current of the Motor Module is: $210 \text{ A} \times 0.809 = 170 \text{ A}$
- the base load current for high overloading is: $178 \text{ A} \times 0.809 = 144 \text{ A}$

IEC 60664-1 stipulates that voltage derating is required.

The selected unit can be operated up to a voltage of $480 \text{ V} \text{ 3 AC} \times 0.88 = 422 \text{ V 3 AC}$ or $720 \text{ V DC} \times 0.88 = 634 \text{ V DC}$, i.e. under these conditions, a 400 V asynchronous motor (induction motors) can be operated without restriction. Due to the installation altitude, however, derating might be required for the asynchronous motor (induction motors).

Configuration (continued)

Selection of the Power Module or Motor Module

The Motor Module is selected initially on the basis of standstill current $I_{0\ 100\ K}$ (rated current for winding temperature rise 100 K) for synchronous motors and the rated current I_{rated} for asynchronous motors (induction motors), and is specified in the motor description. Dynamic overloads, e.g. during acceleration, must be taken into account by duty cycles and may demand a more powerful Power Module or Motor Module. In this context, it is also important to remember that the output current of the Power Module or Motor Module decreases as a function of installation altitude, ambient temperature and pulse frequency setting (see explanations of derating characteristics).

For an optimum configuration, the rms motor current I_{load} calculated from the duty cycle is replicated on the Power Module or Motor Module. The following must apply:

$$I_{\text{rated, module}} \geq I_{\text{load}}$$

$I_{\text{rated, module}}$ = permissible continuous current of Power Module or Motor Module taking derating characteristic curves into account

The Power Modules or Motor Modules can be required to supply a higher output current for specific time periods. To configure an overload, the following must apply:

$$I_{\text{rated, module}} \times \text{overload factor} < I_{\text{overload}}$$

Overload factor = ratio $I_{\text{rated, module}}/I_{\text{max}}$, taking switching cycles into account (see component descriptions).

SIZER is capable of performing precise overload calculations.

Rated current – permissible and non-permissible motor/converter combinations

- Motor rated current higher than rated output current of the Power Module or Motor Module:
In cases where a motor with a higher rated current than the rated output current of the Power Module or Motor Module is to be connected, the motor will only be able to operate under partial load. The following limit applies:
The short-time current ($= 1.5 \times$ base load current I_{H}) should be higher or equal to the rated current of the connected motor. Adhering to this dimensioning rule is important because the low leakage inductance of large motors causes current peaks which may result in drive system shutdown or in continuous output limiting by the internal protective electronic circuitry.
- Motor rated current significantly lower than rated output current of the Power Module or Motor Module:
With the sensorless Vector control system used, the motor rated current must equal at least $\frac{1}{4}$ of the rated output current of the Power Module or Motor Module. With smaller motor currents, the drive can be operated in V/f control mode.

Using pulse width modulation, the Power Modules or Motor Modules generate an AC voltage to feed the connected motor from the DC voltage of the DC link. The magnitude of the DC link voltage is determined by the line voltage and, in the case of a Motor Module, by the Line Module used and thus the maximum possible output voltage (see component descriptions). The speed and loading of the connected motor define the required motor voltage. The maximum possible output voltage must be greater than or equal to the required motor voltage; it may be necessary to select a motor with a different winding.

It is not possible to utilize all modes of pulse width modulation when a sinusoidal filter is connected. The maximum possible output voltage (see sinusoidal filter) is lower as a result.

Long motor cables

Using pulse width modulation, the Power Modules or Motor Modules generate an AC voltage to feed the connected motor from the DC voltage of the DC link. Capacitive leakage currents are generated in clocked operation and these limit the permissible length of the motor cable. The maximum permissible motor cable length is specified for each Power Module or Motor Module in the component description.

Motor reactors limit the rate of rise and magnitude of the capacitive leakage currents, thereby allowing longer motor cables to be used. The motor reactor and motor cable capacitance form an oscillating circuit which must not be stimulated by the pulse pattern of the output voltage. The resonant frequency of this oscillating circuit must therefore be significantly higher than the pulse frequency. The longer the motor cable, the higher the cable capacitance and the lower the resonant frequency. To provide a sufficient safety margin between this resonant frequency and the pulse frequency, the maximum possible motor cable length is limited, even when several motor reactors are connected in series. The maximum cable lengths in combination with motor reactors are specified in the technical data for the motor reactors.

Configuration (continued)

Booksize format Motor Modules

Where a long motor cable is required, a higher rating of Motor Module must be selected or the permissible continuous output current $I_{\text{continuous}}$ must be reduced in relation to the rated output current I_{rated} . The configuring data for booksize format Motor Modules are given in the following table:

Motor Module	Length of motor cable (shielded)			
	> 50 m (165 ft) to 100 m (328 ft)	> 100 m (328 ft) to 150 m (492 ft)	> 150 m (492 ft) to 200 m (656 ft)	> 200 m (656 ft)
3 A/5 A	Use Motor Module 9 A	Use Motor Module 9 A	Not permissible	Not permissible
9 A	Use Motor Module 18 A	Use Motor Module 18 A	Not permissible	Not permissible
18 A	Use Motor Module 30 A or $I_{\text{max}} \leq 1.5 \times I_{\text{rated}}$ $I_{\text{continuous}} \leq 0.95 \times I_{\text{rated}}$	Use Motor Module 30 A	Not permissible	Not permissible
30 A	Permissible	$I_{\text{max}} \leq 1.35 \times I_{\text{rated}}$ $I_{\text{continuous}} \leq 0.9 \times I_{\text{rated}}$	$I_{\text{max}} \leq 1.1 \times I_{\text{rated}}$ $I_{\text{continuous}} \leq 0.8 \times I_{\text{rated}}$	Not permissible
45 A/ 60 A	Permissible	$I_{\text{max}} \leq 1.75 \times I_{\text{rated}}$ $I_{\text{continuous}} \leq 0.9 \times I_{\text{rated}}$	$I_{\text{max}} \leq 1.5 \times I_{\text{rated}}$ $I_{\text{continuous}} \leq 0.85 \times I_{\text{rated}}$	Not permissible
85 A/ 132 A	Permissible	$I_{\text{max}} \leq 1.35 \times I_{\text{rated}}$ $I_{\text{continuous}} \leq 0.95 \times I_{\text{rated}}$	$I_{\text{max}} \leq 1.1 \times I_{\text{rated}}$ $I_{\text{continuous}} \leq 0.9 \times I_{\text{rated}}$	Not permissible
200 A	Permissible	$I_{\text{max}} \leq 1.25 \times I_{\text{rated}}$ $I_{\text{continuous}} \leq 0.95 \times I_{\text{rated}}$	$I_{\text{max}} \leq 1.1 \times I_{\text{rated}}$ $I_{\text{continuous}} \leq 0.9 \times I_{\text{rated}}$	Not permissible

The permissible cable length for an unshielded motor cable is 150% of the length for a shielded motor cable.

Motor reactors can also be used on motors operating in Vector and V/f control modes to allow the use of longer motor cables.

Line Modules

In multi-axis drive applications, a number of Motor Modules are operated on a common DC link, which is supplied with power by a Line Module.

The first task is to decide whether a Basic Line Module, Smart Line Module or an Active Line Module will be used. On the one hand, this depends on whether the drive must be capable of regenerative feedback to the supply and, on the other hand, whether the power supply infeed is to be unregulated and therefore dependent on the power supply voltage, or regulated to a constant DC link voltage.

Booksize Line Modules are available in smart and active formats and are both regenerative back to the supply.

The chassis format units are available in the 380 V to 480 V voltage range, but also include units in the 660 V to 690 V range. Basic Line Modules are designed for infeed operation only. Active Line Modules have regulated infeeds which feature a step-up function.

In order to calculate the required DC link power and select the correct Line Module, it is important to analyse the entire operating sequence of the drive group connected to the DC link. Factors such as partial load, redundancies, duty cycles, coincidence factors and the operating mode (motor / generator mode) must be taken into account.

The DC link power P_d of a single Motor Module is calculated from the shaft output P_{mech} of the motor and the efficiency of the motor η_m and Motor Module η_{wr}

The following applies in motor mode: $P_d = P_{\text{mech}} / (\eta_m \times \eta_{wr})$

The following applies in generator mode: $P_d = P_{\text{mech}} \times \eta_m \times \eta_{wr}$

The motor and generator outputs must be added with the corresponding sign in order to calculate the total DC link power.

The rated infeed power of the Line Module refers to a line voltage of 380 V, 460 V or 690 V (690 V applies only to chassis format Line Modules). Fluctuations in line voltage can affect the output power of the Line Modules. However, the maximum possible output corresponds to the rated power of the relevant type size.

Depending on the ambient conditions (installation altitude, ambient temperature), the rated infeed power of the Line Modules may need to be reduced (see component description).

The coincidence factor takes into account the time characteristic of the torque for each individual axis.

On the basis of these principles, the following procedure can be used to dimension the Line Module:

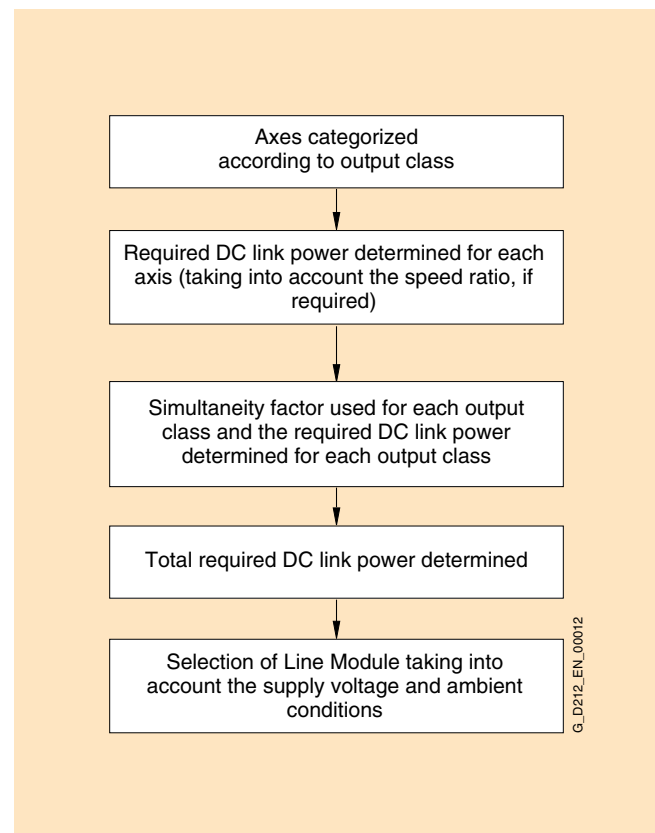

Configuration (continued)

The following factors must also be taken into account when dimensioning the DC link:

■ Braking operation

As device losses are important in motor mode, the dimensioning for motor mode is also applicable to generator mode. With respect to motor braking operation, check that the energy fed back into the DC link does not exceed the permissible peak load capability of the Line Module.

In the case of higher regenerative outputs and to control the "line failure" operating scenario, a Braking Module must be provided, the Smart or Active Line Module must be overdimensioned or the regenerative output reduced by longer braking times.

For the configuration of the "EMERGENCY STOP" operating scenario, the Line Module must either be overdimensioned or an additional Braking Module must be used, so that the DC link energy can be dissipated as quickly as possible.

■ Checking the DC link capacitance

During power-up, the Line Modules limit the charging current for the DC link capacitors. Due to the limits imposed by the pre-charging circuit, it is essential to observe the maximum permissible DC link capacitance values for the drive group specified in the technical data.

■ DC link pre-charging frequency

The pre-charging frequency of the DC link via a booksize format Line Module is calculated using the following formula:

$$\text{Number of pre-charges within 8 mins} = \frac{\text{max. permissible DC link capacity infeed unit in } \mu\text{F}}{\Sigma \text{ DC link capacity of configured drive line - up in } \mu\text{F}}$$

For chassis format Line Modules, the maximum permissible DC link pre-charging interval is 3 minutes.

■ Special considerations for operation on Basic or Smart Line Module

Basic Line Modules and Smart Line Modules provide a lower DC link voltage than Active Line Modules. As a result, the following boundary conditions apply:

- When operating asynchronous motors (induction motors), a lower maximum motor power is available at high speeds at the same line voltage.
- On synchronous motors, a reduction in the dynamic drive characteristics must be expected at high speeds.
- On synchronous motors, the rated motor speed cannot be fully utilized when an overload capability is required.

Basic Line Modules

The DC link voltage U_d of the Basic Line Modules is load-dependent. Under no-load conditions, the DC link is charged to the line voltage crest value U_L , i.e. $U_d = \sqrt{2} \times U_L$, e.g. $U_d = 650 \text{ V}$ when a 460 V supply system is connected.

Under load conditions, the DC link voltage reaches the average value of the rectified line voltage applied to the terminals. This average value is determined by the line voltage x factor 1.35. Owing to the voltage drop across the line reactor and in the line feeder cable, the DC link voltage under full load conditions is slightly lower than the theoretical value. In practice, the range of the DC link voltage U_d is as follows:

$$1.41 \times U_L > U_d > 1.32 \times U_L \text{ (no load } \rightarrow \text{ rated output)}$$

Smart Line Modules

The DC link voltage U_d of Smart Line Modules is regulated to the average value of the rectified line voltage U_L , i.e. $U_d \approx 1.35 \times U_L$

Due to the voltage drop across the line reactor and in the line feeder cable, the DC link voltage decreases in motor operation and increases in generator operation. The DC link voltage U_d thus varies within the same range as on drives with a Basic Line Module:

$$1.41 \times U_L > U_d > 1.32 \times U_L \text{ (rated output generator mode } \rightarrow \text{ rated output motor mode)}$$

Active Line Modules

The DC link voltage U_d is regulated to an adjustable value (Active Mode). An Active Line Module can also be switched to Smart Mode and then operates like a Smart Line Module. In Active Mode, the Active Line Module draws a virtually sinusoidal current from the supply system.

Parallel connection of power units

Up to 4 Motor Modules or Line Modules in chassis format can be connected in parallel. Parallel connections can operate only in Vector control mode.

Parallel connections may only include Motor Modules or Line Modules of the same type and with the same voltage and output ratings. Mixtures of different modules, e.g. Basic Line Modules and Active Line Modules, cannot be connected in parallel. The CU320 or SIMOTION D Control Unit can control only one drive object of type "Parallel connection Line Modules" and one of type "Parallel connection Motor Modules". It is assumed that all Line Modules or Motor Modules linked to the Control Unit are connected in parallel. A Control Unit can control, for example, the following components:

1 Line Module + 2 Motor Modules connected in parallel, 2 Line Modules connected in parallel + 3 Motor Modules connected in parallel. Combinations such as the following are not permissible: 2 Line Modules + 2 Motor Modules connected in parallel + 1 Motor Module

In order to ensure symmetrical current distribution among all parallel-connected modules, inductances must be provided for subsystem decoupling. However, the current compensatory control cannot completely prevent asymmetrical current distribution, which means that the following derating factors apply to parallel connections:

Designation	Derating factor for parallel connection of 2 to 4 Modules	Max. permissible number of parallel-connected Modules
Active Line Modules	0.95	4
Basic Line Modules	0.925	4
Motor Modules	0.95	4

Configuration (continued)

Chassis format Line Modules

Line reactors are needed to decouple individual Basic Line Modules, while the appropriate Active Interface Modules are required to decouple Active Line Modules.

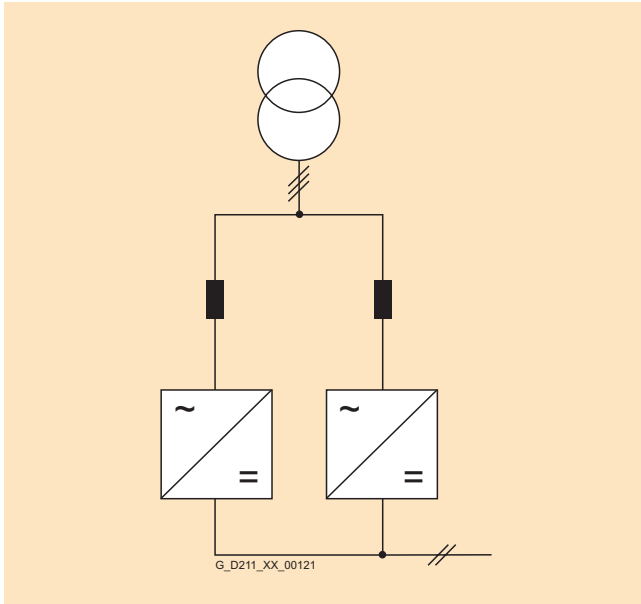

Parallel connection of Basic Line Modules using line reactors

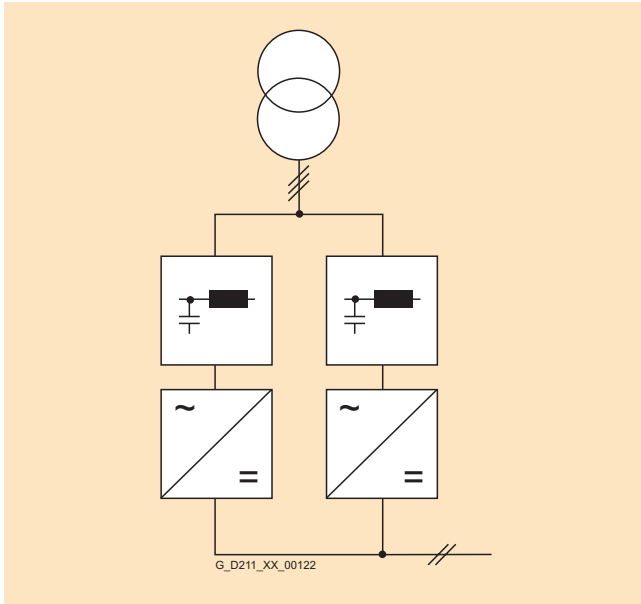

Parallel connection of Active Line Modules using Active Interface Modules

Chassis format Motor Modules

Three-wire or four-wire cables should be used where possible to connect Motor Modules in parallel.

In this case, a minimum clearance of 50 mm (1.97 in) must be left between the cables of the individual subsystems. A three-phase system must be connected to each of the cables of equal length (U2, V2, W2). In order to ensure adequate decoupling between subsystems, the motor cables must be of a minimum length so as to provide the necessary inductance.

Motor Module	P_M	$I_{rated\ rms}$	Minimum length of motor feeder cable
Frame size	kW	A	m (ft)
Output voltage 380 V to 480 V			
FX	110	210	45 (148)
FX	132	260	40 (132)
GX	160	310	35 (115)
GX	200	380	30 (98)
GX	250	490	30 (98)
HX	315	605	30 (98)
HX	400	745	25 (82)
HX	450	840	20 (66)
JX	560	985	15 (49)
JX	710	1260	10 (33)
JX	800	1405	10 (33)
Output voltage 660 V to 690 V			
FX	75	85	150 (492)
FX	90	100	150 (492)
FX	110	120	110 (361)
FX	132	150	110 (361)
GX	160	175	90 (295)
GX	200	215	60 (197)
GX	250	260	50 (164)
GX	315	330	30 (98)
HX	400	410	30 (98)
HX	450	465	30 (98)
HX	560	575	25 (82)
JX	710	735	20 (66)
JX	800	810	20 (66)
JX	900	910	15 (49)
JX	1000	1025	15 (49)
JX	1200	1270	10 (33)

If the drive configuration cannot accommodate the minimum required cable length, the appropriate motor reactor for the Motor Module must be installed. Alternatively, motors with two separate winding systems can be used.

The latter option is preferable for drives with higher outputs, as the motor terminal boxes are subject to current limits in this case. Motors with separate winding systems allow all types of modulation (i.e. space vector modulation and edge modulation). If the parallel-connected Motor Modules are supplying a joint winding system, edge modulation cannot be used and the maximum possible line-to-line output voltage U_a is limited to $0.67 \times$ DC link voltage.

Further information

System description

Power Units

Configuration (continued)

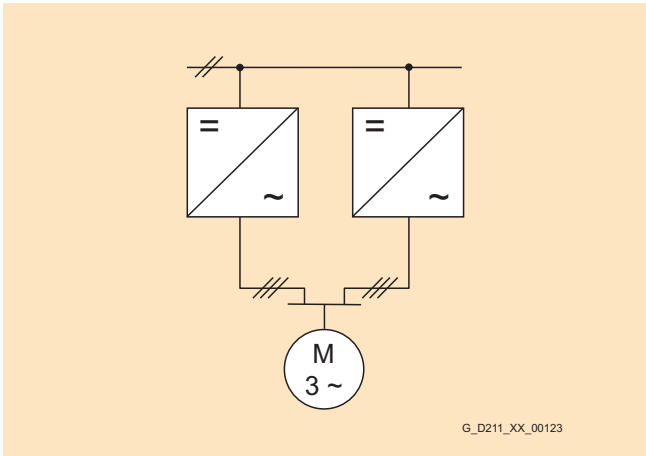

Parallel connection with identical motor cables of the required minimum length

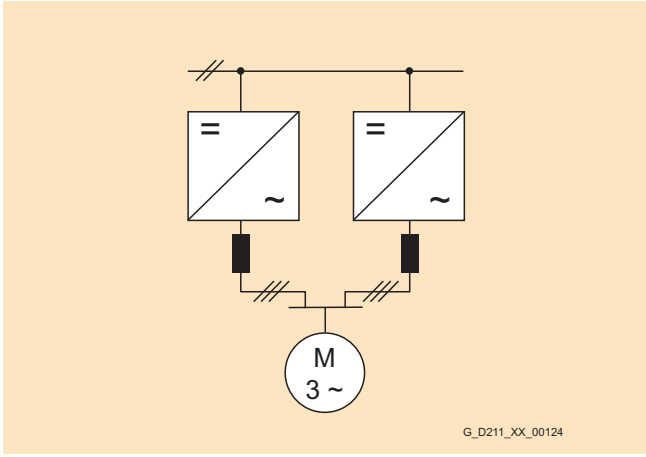

Use of motor reactors

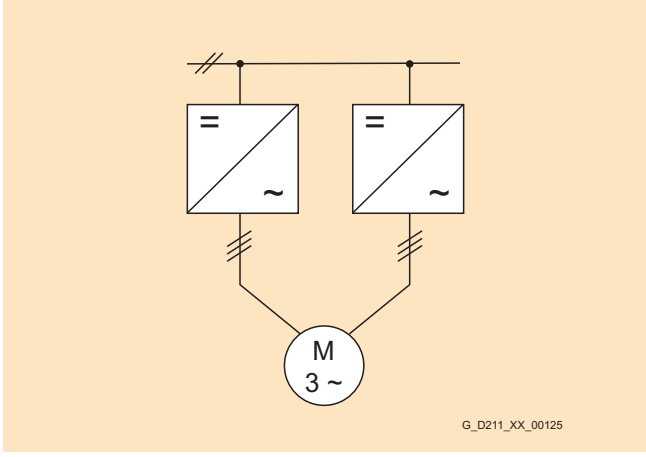

Asynchronous motor (induction motors) with two separate winding systems

Fan control

Units in booksize format feature a temperature-controlled fan for cooling the power unit. The fan is not switched on until the heat sink temperature exceeds the threshold value of 56 °C (132.8°F). The fan is supplied by an external 24 V DC power source or from the DC link via a switched-mode power supply.

On blocksize and chassis units, the fan is switched on when the power unit pulses are enabled.

System disturbance

The voltage drops across the impedance between the supply system and a load as soon as the load draws current. In a symmetrical three-phase supply system, this is the network impedance Z_n which is calculated from the impedance Z_s of the supply system and the line-side impedance Z_e of the load.

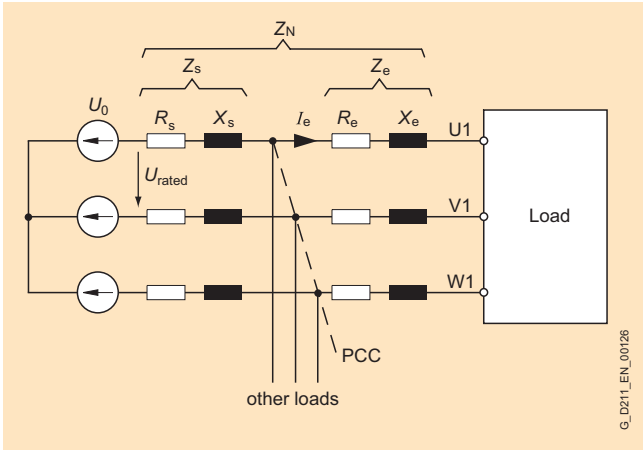

Effective impedance when a load is connected to a three-phase supply system

$$Z_n = Z_s + Z_e = R_s + j X_s + R_e + j X_e = R_n + j X_n$$

On a variable-speed drive, the line-side impedance Z_e is normally the total impedance provided by the line reactor and the feeder cable up to the PCC (Point of Common Coupling) for further loads. The ohmic component R_n is generally negligible as compared to the inductive component X_n . The inductance of an RI suppression filter is irrelevant for the purpose of this calculation, as this inductance is effective only for asymmetrical interference voltages, but not for a symmetrical line current.

If a load causes voltage drops across the impedance Z_s , this system disturbance has an impact at the PCC and thus also in the supply voltage to all other loads.

The voltage drop is proportional to current I_e and the impedance. To facilitate comparison of voltage drops under different supply and load conditions, the voltage drop is specified – normally at rated current – with reference to the phase voltage U_0 . The calculation formula, e.g. for the per unit voltage drop u_k across an impedance Z is as follows:

$$u_k = Z \times I_e / U_0$$

Configuration (continued)

Example 1:

A Power Module with rated line current I_e is directly connected to a low-voltage transformer and the PCC is the transformer connection terminal. The equation for the ratio between rated line current I_e of the Power Module and rated current I_{rated} of the transformer is $I_e = 0.25 \times I_{rated}$. The per unit voltage drop u_k of the 400 V transformer is 4%. If the transformer is loaded with its rated current I_{rated} , the voltage drop across impedance Z_s is 9.2 V (corresponding to 4% of the phase voltage $U_o = 230$ V).

$$u_k = (Z_s \times I_{rated}) / 230 \text{ V} = 0.04$$

The following formula applies to the rated line current I_e of the Power Module: $I_e = k \times I_{rated}$

The per unit voltage drop across the transformer when loaded with I_e is thus: $u_k = Z_s \times I_e / U_o = Z_s \times k \times I_{rated} / U_o$

With the specified ratio between I_e and I_{rated} , the per unit voltage drop $u_k = 1\%$ or 2.3 V. In relation to the Power Module, this transformer therefore functions like a line impedance in accordance with $u_k = 1\%$.

The magnitude of system disturbance in converter systems is assessed on the basis of short-circuit power ratio R_{sc} :

$$R_{sc} = S_{cv} / P$$

According to this definition in EN 60146-1, P is the fundamental-wave apparent power drawn by the converter. S_{cv} is the short-circuit power drawn from the supply in the event of a short circuit at terminals U1, V1 and W1. Since the ohmic components of impedances are negligible in practice, $Z_n \approx j X_n$ applies

$$S_{cv} \approx 3 \times U_o^2 / X_n$$

$$\text{and thus } R_{sc} \approx 3 \times U_o^2 / (X_n \times P)$$

The short-circuit power ratio R_{sc} is therefore dependent on the current output power P of the converter and is determined by network impedance X_n .

If we assume the power to be $P \approx 3 \times U_o \times I_e = \sqrt{3} \times U_{rated} \times I_e$

the short-circuit power ratio R_{sc} is indirectly proportional to the per unit voltage drop u_k across the effective line impedance.

$$R_{sc} \approx 3 \times U_o^2 / (X_n \times P) = 3 \times U_o^2 / (X_n \times 3 \times U_o \times I_e) = U_o / (X_n \times I_e) = 1 / u_k$$

The short-circuit power ratio for example 1 is therefore $R_{sc} \approx 100$ if no line reactor is installed ($Z_e = 0$).

Note:

The term "short-circuit power ratio" as used in technical standards is not a harmonized definition. The short-circuit power ratio R_{scc} defined according to IEC 61000-3-12 is calculated from the short-circuit power S_{sc} at the PCC referred to the power $S_{equ} = 3 \times U_o \times I_e$ consumed by the load.

Basic Line Modules and Power Modules are designed with a rectifier bridge on the line side. An inherent feature of the principle of rectification with load-side capacitance for DC link voltage smoothing are harmonics in the line current which result in a non-sinusoidal power input. The diagram shows the basic current waveform of a Power Module or Basic Line Module as a function of short-circuit power ratio R_{sc} .

Active Line Modules generate virtually no current harmonics (Active Mode) at all and are employed when system disturbance needs to be minimized, e.g. stipulation of IEEE 519 that THD (Total Harmonic Distortion) must be $< 10\%$.

The SIZER configuring tool calculates the system disturbance on the basis of the supply data entered and lists them against the limit values of relevant standards.

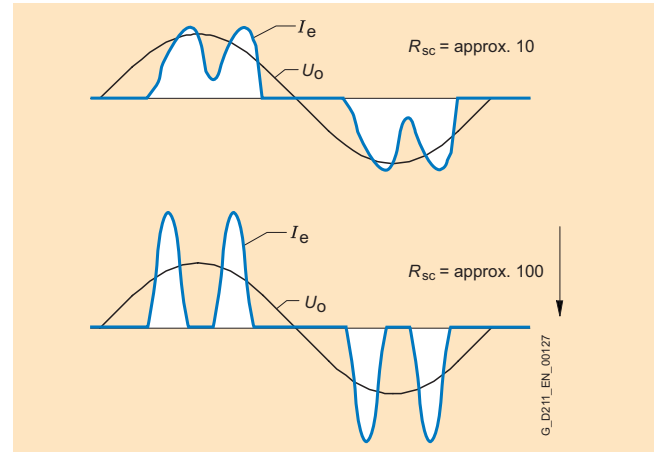

Line current of a Basic Line Module or Power Module as a function of the short-circuit power ratio R_{sc}

The rms of the line current I_e for which the line-side components must be rated comprises fundamental wave I_{e1} and the current harmonics, which increase in relation to the rise in short-circuit power ratio R_{sc} . If the DC link power P_d has been calculated (see Line Modules), the required line-side active power is a known quantity with Line Module efficiency, or the rectifier efficiency in the case of a Power Module. However, this active power is connected only with the current fundamental wave I_{e1} . The rms of the line current I_e is always greater than I_{e1} as a result of the current harmonics. The following applies for a short-circuit power ratio $R_{sc} = 100$:

$$I_e \approx 1.3 \times I_{e1}$$

The apparent power of a transformer selected to supply the drive must be greater than the drive power by a factor of about 1.3.

The harmonic currents produce only alternating power, but no active power. The following applies to the apparent power S on the line side:

$$S^2 = P^2 + Q_1^2 + D^2$$

- with active component
 $P = 3 \times U_o \times I_1 \times \cos \phi_1$ produced solely by the current fundamental wave
- and reactive component
 $Q_1 = 3 \times U_o \times I_1 \times \sin \phi_1$
- and the distortion component

$$D = 3 \times U_o \sqrt{\sum_{v=2}^{\infty} I_v^2}$$

The ratio between active power and apparent power is referred to as power factor λ or total power factor:

$$\lambda = \frac{P}{S} = \frac{P}{\sqrt{P^2 + Q_1^2 + D^2}}$$

Further information

System description

Power Units

Configuration (continued)

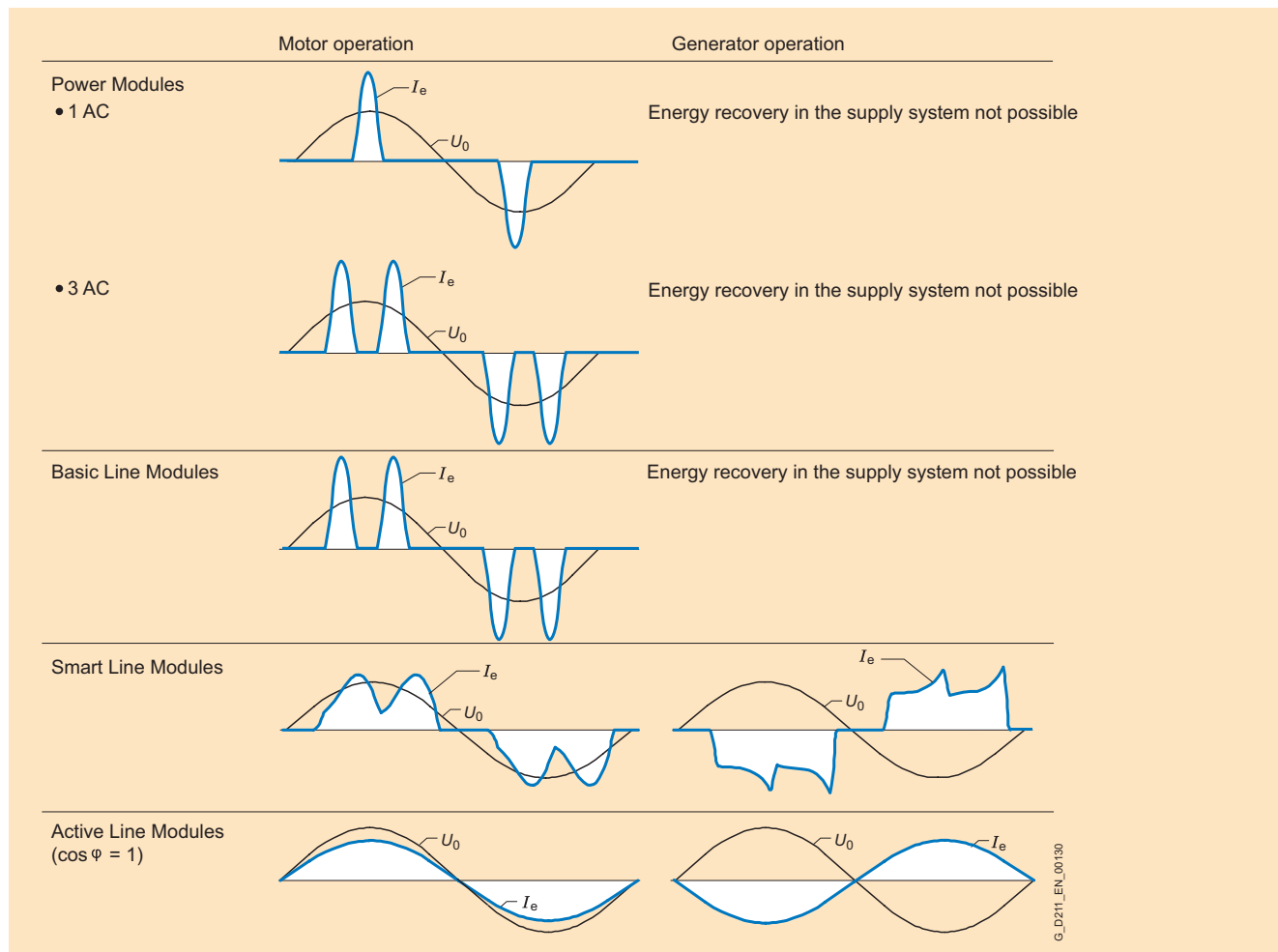

G_D211_EN_00130

Typical waveform of the line current with Power Modules and Line Modules

Configuration (continued)

Line-side options (main switch, fuses, line filters, etc.)

The following line-side options are recommended for the drive configuration:

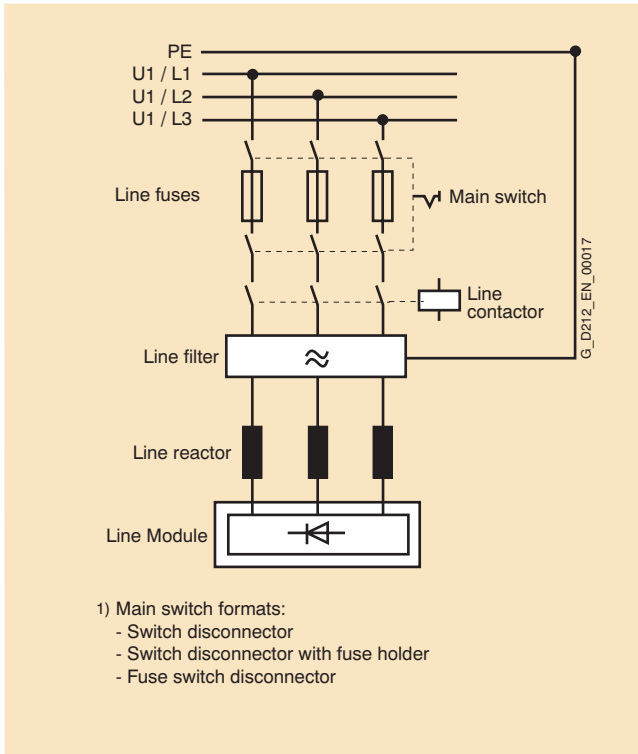

The main switch may take various formats:

- Main and EMERGENCY STOP switch + fuse switch disconnecter (with leading signal via auxiliary contact for trip mode)
- Load interruptor with fuses
- Circuit-breaker

To protect the units against line-side surge voltages, it is advisable to install overvoltage protection directly at the infeed point (upstream of main switch). Surge protection is essential in order to satisfy the requirements of Canadian standard CSA C22.2 No. 14. For examples of suitable surge voltage arresters, go to <http://www.raycap.com>

Depending on the performance required, a fuse switch disconnecter combined with a contactor or a circuit-breaker can be provided as the main switch.

A line contactor can be used, for example, if the drive has to be disconnected from the line supply in the event of a fault or for remote tripping. Follow the instructions in the SINAMICS S120 Configuration Guides to interlock the line contactor in the context of safety functions.

A line filter should be used on TN (grounded) systems to reduce system disturbance.

Further information

System description

System Components

Configuration (continued)

Motor reactors

High-speed switching of the power transistors causes capacitive charge/discharge currents in the motor cable and motor, as well as steep voltage rises and peak voltages in the motor windings. These currents can be reduced through the installation of a motor reactor.

The voltage drop across the motor reactor is normally negligible at output frequencies of 60 Hz and below. The per unit voltage drop u_k across the reactor is between 1% and 4% at rated current and 50 Hz. With a $\cos \varphi$ of 0.86 and an output frequency of 50 Hz, the motor voltage across the motor reactor is about 2% lower than in systems without a motor reactor.

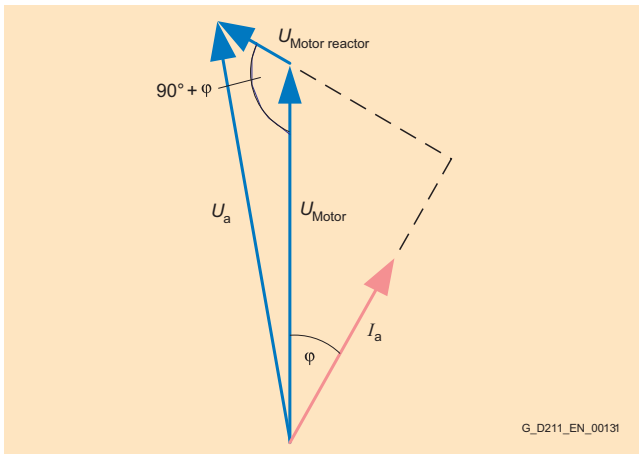

Motor reactors are approved for use only in conjunction with Vector and V/f control modes. Motor reactors are compatible with all modulation types (space vector modulation, edge modulation).

Sinusoidal filters

Sinusoidal filters are low-pass LC filters which allow easy passage to only the fundamental component of the square-wave, pulse-width-modulation output voltage of a Power Module or Motor Module. The resonant frequency of the sinusoidal filter must be significantly lower than the pulse frequency of the Power Module or Motor Module and be dimensioned with a sufficient margin to the maximum permissible output frequency. Sinusoidal filters therefore define the choice of pulse frequency and place a limit on the maximum possible output frequency. This type of filter is compatible only with space vector modulation. The output voltage of a Power Module or Motor Module is thus limited to an output voltage (rms value) of approximately $0.67 \times$ DC link voltage. With the voltage drop across the sinusoidal filter, the maximum possible output voltage (rms value) is approximately $0.63 \times$ DC link voltage. A sinusoidal filter is registered on the Control Unit by a parameter setting, where defaults for all the relevant filter-dependent values, such as permissible modulation types, maximum output frequency, etc. are stored.

Sensor Modules

Signal conditioning for various encoders (incremental encoder $\sin/\cos 1 V_{pp}$, absolute encoder, resolver) are converted to DRIVE-CLiQ signals through sensor modules. Depending on the measuring system, SMC10, SMC20 or SMC30 Sensor Modules will be used. The Sensor Modules are designed to be mounted on DIN rails. They are also used for the signal conditioning of external (machine) encoders.

Expansion Modules

Even the standard version of the CU320 Control Unit features interfaces and terminals for communication. SINAMICS S120 offers the following expansion modules:

- TB30 Terminal Board (terminal expansion for plugging into the option slot on the CU320 Control Unit)
- TM31 Terminal Module (terminal expansion for connection via DRIVE-CLiQ)

The following criteria regarding the use of expansion modules must be taken into account:

- Only one option board can be plugged into the option slot on the CU320 Control Unit.
- A maximum of 8 Terminal Modules may be operated in a drive group.

Braking Modules and braking resistors

Braking units comprise of a Braking Module and a braking resistor, which must be attached externally.

Braking units are used when

- regenerative energy occurs occasionally and briefly, for example when the brake is applied to the drive (EMERGENCY STOP) and the drive has no regenerative feedback capability
- the drive features regenerative feedback units, but cannot return the energy fast enough to the supply on an "EMERGENCY STOP"
- the drive needs to be shut down after a power failure

The braking units for Power Modules in blocksize format consist of braking resistors only, as they feature a Braking Module as standard.

A number of Braking Modules can be connected in parallel to the DC link in order to increase the braking power. Each Braking Module requires its own braking resistor. It is not permissible to operate a mix of braking units in booksize and chassis format on the same DC link.

The braking power required is calculated from the DC link power P_d of the drive group or Power Module in generator operation.

Configuration (continued)

Braking Modules and braking resistors for booksize format

To operate booksize format Braking Modules, a minimum capacitance is required in the DC link. This capacitance is determined by the braking resistor used.

Braking resistor 0.3 kW/25 kW → DC link capacitance 220 μ F

Braking resistor 1.5 kW/100 kW → DC link capacitance 330 μ F

The capacitance of the booksize format Braking Module of 110 μ F is included in the total capacitance value. If the DC link capacitance is not sufficient for the use of one or more Braking Modules, a Capacitor Module can be added to increase the effective DC link capacitance of the drive group.

When booksize format Braking Modules are connected in parallel, the minimum capacitance specified above must be available for each Braking Module.

Note: Only booksize format modules that are directly connected to each other via the DC link busbar can be included in the total capacitance.

If the DC link capacitance is not sufficient for the operation of a number of Braking Modules, Capacitor Modules can be used to increase the DC link capacitance. The max. permissible DC link capacitance of a drive group on a Line Module must be taken into account. The max. DC link capacitances to be taken into account for pre-charging current limiting on the Line Modules are listed in the technical specifications for the Line Modules.

The braking resistor discharges the excess energy from the DC link:

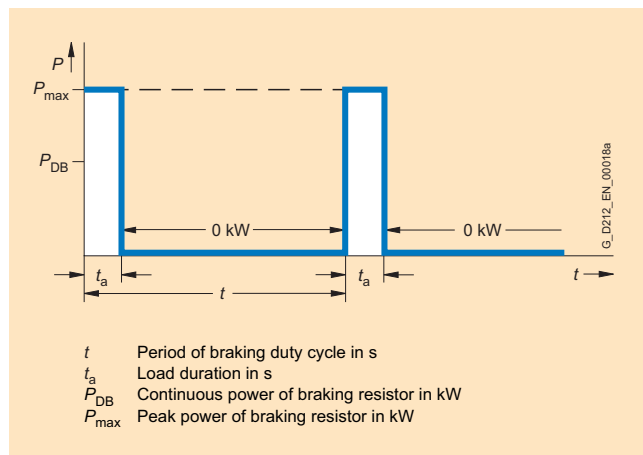

Duty cycle for braking resistors

Braking Modules and braking resistors for chassis format

Braking Modules with a braking power of 25 kW (for type FX) and 50 kW (for types GX, HX and JX) are available with matching braking resistors for chassis format units. Braking units can be connected in parallel to obtain higher braking powers. In this case, the units can be installed at the Line Module end or Motor Module end.

When a Braking Module is installed in a Basic Line Module of size GB, the cables supplied for the DC link connection are too short. In this case, the cable harness set 6SL3366-2NG00-0AA0 must be ordered to make the Braking Module connection.

Frame size	Rated power P_{DB}	Peak power P_{15}	Max. possible mounting locations for Braking Module
FB	25 kW	125 kW	1
GB	50 kW	250 kW	1
FX	25 kW	125 kW	1
GX	50 kW	250 kW	1
HX	50 kW	250 kW	2
JX	50 kW	250 kW	3

The Braking Module features an electronics interface (X21) with monitoring function. The braking resistor housing contains a monitoring thermocontact. Both these monitors can be integrated into the warning or shutdown circuits of the drive system.

Further information

System description

System Components

Configuration (continued)

Calculation of Braking Module and braking resistor requirements

- For periodic duty cycles with a cycle duration of ≤ 90 s, the average value of the braking power within this duty cycle must be defined. The relevant cycle duration must be applied as the time base.
- For periodic duty cycles with a cycle duration of ≥ 90 s or for sporadic braking operations, a time interval of 90 s in which the highest average value occurs must be selected. The 90 s period must be applied as the time base.

Apart from the average braking power, the required peak braking power must also be taken into account when braking units are selected (Braking Module and braking resistor).

Basic data

Supply voltage	Power range Motor Modules	Braking Module Continuous power P_{DB}	Braking Module Power P_{40}	Braking Module Power P_{20}	Braking Module Peak power P_{15}
380 V to 480 V	110 kW to 132 kW	25 kW	50 kW	100 kW	125 kW
	160 kW to 800 kW	50 kW	100 kW	200 kW	250 kW
660 V to 690 V	75 kW to 132 kW	25 kW	50 kW	100 kW	125 kW
	160 kW to 1200 kW	50 kW	100 kW	200 kW	250 kW

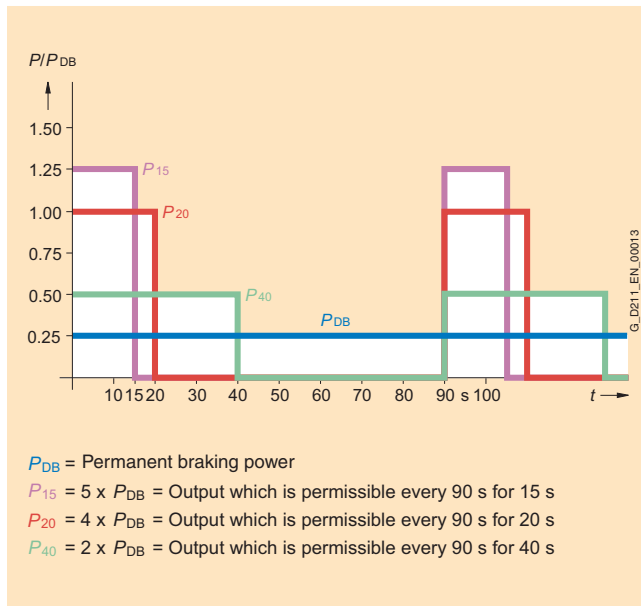

Load diagram

Braking resistors for Power Modules in blocksize format

The braking resistors for the FSA and FSB frame sizes are designed as substructure components. Braking resistors for frame sizes FSC to FSF should be mounted outside the control cabinet due to their high heat losses.

The Control Unit monitors the pulse/pause ratio (ON time/OFF time) of the braking resistor and shuts it down on faults if it calculates that the resistor is at risk of overheating.

Braking resistors feature a temperature switch with NC contacts that open when the permissible temperature is exceeded. The temperature switch must be evaluated to prevent consequential damage if the braking resistor overheats.

The braking power P_{mech} on the motor shaft is higher than the power loss of the braking resistor, as this only needs convert the DC link energy into heat. The DC link power P_d of the Power Module in generator mode is calculated from the shaft power P_{mech} of the motor and the power loss in the motor $P_{v Motor}$ and in the Power Module $P_{v Power Module}$ as:

$$P_d = P_{mech} - P_{v Motor} - P_{v Power Module} = P_{braking resistor}$$

These power losses can be estimated from the efficiency values of the motor η_m and Power Module η_{wr} :

$$P_{braking resistor} = P_d = P_{mech} \times \eta_m \times \eta_{wr}$$

Booksize format Capacitor Module

The Capacitor Module functions as a short-term energy buffer, e.g. for bridging brief power failures or for storing braking energy. The buffered energy W can be calculated with the following formula:

$$W = \frac{1}{2} \times C \times (U_{d1}^2 - U_{d2}^2)$$

C = effective capacity of Capacitor Module 4 mF

U_{d1} = DC link voltage when buffering starts

U_{d2} = DC link voltage when buffering ends

Example:

$$U_{d1} = 600 \text{ V}; U_{d2} = 430 \text{ V}$$

The resultant energy calculation is $W = 350 \text{ Ws}$

With this energy, for example, it is possible to buffer a 3 kW Motor Module for about 100 ms.

Booksize format Control Supply Module

The Control Supply Module provides a 24 V DC power supply via the line or DC link in order to maintain the electronics power supply for the components in the event of a line failure. This makes it possible, for example, to make emergency retraction movements in the event of the failure of the line supply.

Configuration (continued)

External 24 V DC supply of components

Power units (Line Modules and Motor Modules) and other system components must be provided with a 24 V DC voltage via an electronics power supply made available externally.

SITOP devices, which are available as a modular solution, are suggested as the external 24 V DC electronics power supply.

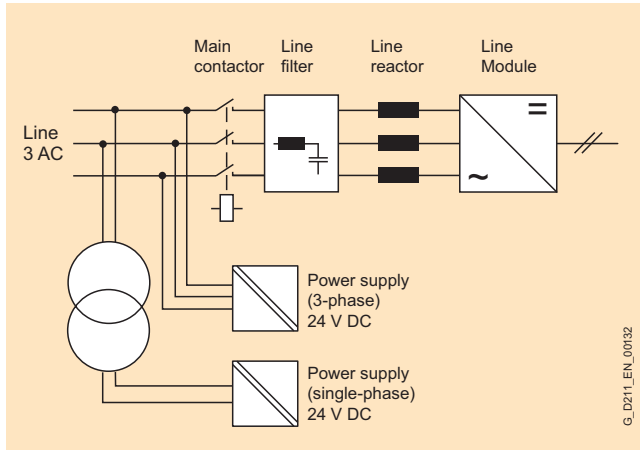

Connecting the external electronics power supply

The current requirement $I_{DC\ ext}$ is calculated with the following formula:

$$\Sigma [\text{Control Unit} + \text{built-in options (e.g. TB30 + CBC10)} + \text{system components} + \text{Line Module} + \Sigma (\text{Motor Modules} + \text{SMCxx} + \text{motor brake control})]$$

The other system components (e.g. line contactor) must also be taken into account.

The current requirement of individual components can be found in the relevant technical data.

Limit values for the configuration:

- The current-carrying capacity of the integrated 24 V DC busbar (featured only in booksize format) is max. 20 A.
- In the event of higher current requirements, a number of 24 V DC power supplies must be provided in one drive group. The other infeeds are implemented by means of 24 V terminal adapters (booksize format only).
- Cable cross sections of up to 2.5 mm² may be connected to the Control Units, Terminal Boards, Terminal Modules and Sensor Modules.
- Cable cross sections of up to 6 mm² may be connected to the 24 V terminal adapters (booksize format only) for the Line Modules and Motor Modules.
- The external 24 V DC power supply should only be used for the SINAMICS components and the direct loads.

Capacitors in the electronics supply of most components must be charged when the 24 V DC supply is first switched on. To charge these capacitors, the power supply must first supply a current peak which can be a multiple of the current requirement $I_{DC\ ext}$ calculated above. Allowance must be made for this current peak when selecting protective elements, e.g. miniature circuit-breakers, for incorporation in the 24 V DC supply system (types with let-through I^2t values according to characteristic D). The current peak flows for an interval t_e of less than 100 ms. The crest value is determined by the impedance of the 24 V DC supply and its electronically limited maximum current.

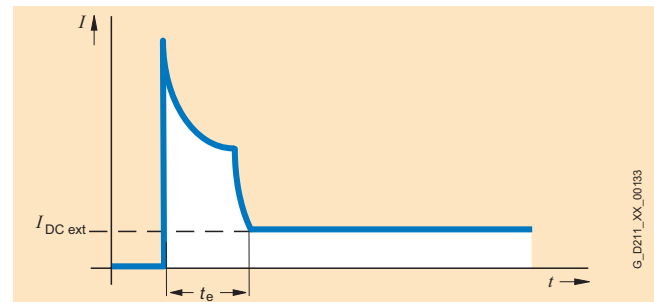

Typical waveform of the switch-on current of the external 24 V DC supply

Further information

System description

Mechanical installation of the drive system

Configuration

Specification of components for connection system

To complete the drive system, components such as motors and encoders must be connected to it via cables.

On motors with DRIVE-CLiQ interface, the 24 V DC power supply is provided via the DRIVE-CLiQ cables. On all other Sensor Modules, a separate 24 V DC power supply must be provided.

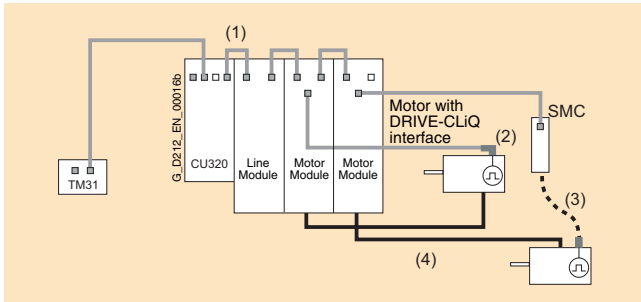

Drive connection system

Legend	Cable	Description
(1)	DRIVE-CLiQ cables	Standard cables for cabinet-internal configuration without 24 V cores
(2)	DRIVE-CLiQ MOTION-CONNECT 500/800 cables	MOTION-CONNECT 500 shielded cables with 24 V cores for fixed installation (e.g. in the cable duct), and MOTION-CONNECT 800 for flexible installation (e.g. in cable carriers)
(3)	MOTION-CONNECT 500/800 signal cables	Suitable for the measuring system in question; in versions MOTION-CONNECT 500 for fixed installation (e.g. in the cable duct), and MOTION-CONNECT 800 for flexible installation (e.g. in cable carriers)
(4)	MOTION-CONNECT 500/800 power cables	MOTION-CONNECT 500 shielded motor cables for fixed installation (e.g. in the cable duct), and MOTION-CONNECT 800 for flexible installation (e.g. in cable carriers)

DRIVE-CLiQ cables are available in various designs and lengths (see connection system).

The required bending radii apply particularly to short cables. In addition to the distance between the two DRIVE-CLiQ sockets to be connected by the cable, a cable length of at least 60 mm (2.36 in) must be allowed for the bending radii.

Unused DRIVE-CLiQ sockets can be protected with a blanking plug. Suitable blanking plugs are available, e.g. from YAMAICHI, order no.: Y-ConAS-13, <http://www.yamaichi.de>

Mechanical configuration of the drive

A SINAMICS S 120 multi-axis drive group comprises of a Line Module, Motor Modules, DC link components, a Control Unit, and the optional expansion modules.

Configuration of a drive group in booksize format

The following criteria must be taken into account when a drive group of booksize format units is configured:

- The Line Module must always be located on the left as the first module.
- Only one Line Module is permitted in each drive group.
- A number of drive groups must be configured for power supplies which cannot be provided by the highest rating.
- The Motor Modules must be located next to the Line Module in descending rated current order from left to right (highest rated current on the left, lowest rated current on the right). Due to the increased currents, Motor Modules with 200 mm (7.67 in) and 300mm (11.81 in) width housings have DC link busbars with increased cross section. Within the drive group, it must be ensured that the DC link busbars meet the current-carrying capacity requirements for all connected Motor Modules.
- DC link adapters can be used to implement multi-tier configurations.
- The drive groups should be configured so that the total length of all power cables for the motor cables and the line cable in each individual group, which should preferably be shielded, is ≤ 350 m (1149 ft). The Voltage Clamping Module must be installed for cable lengths of between 350 m (1149 ft) and 630 m (2067 ft).
- The DC link busbars can be connected on the right and left with Active Line Modules rated for 55 kW, 80 kW and 120 kW. In this case, the drive can be configured in the reverse order (from right to left) or on both sides (see arrangement for chassis format units).
- The Braking Module is usually located on the right, next to the smallest Motor Module. This is particularly important in cases in which the drive group comprises a number of very similar Motor Modules.
- In the event of imbalanced power distribution, e.g. if high-power Motor Modules are being used in conjunction with low-power Motor Modules, the Braking Module must be installed between the Motor Modules whose power ratings differ the most, as the cross sections of the DC link busbars will vary in terms of dimensions due to the current-carrying capacity of the integrated DC link busbars.

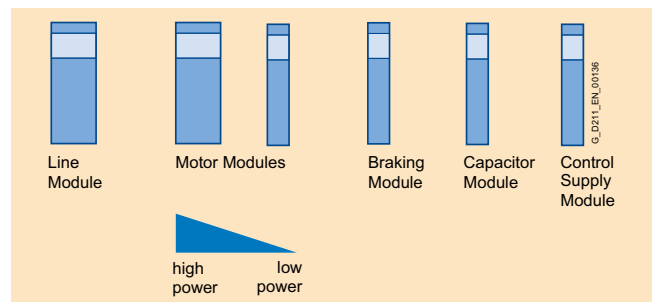

Power-oriented arrangement of booksize format Motor Modules

- The Control Unit configuration is flexible. The following configuration options are possible:
 - "Docking" on the left-hand side of the Line Module
 - Direct mounting next to the drive group on a mounting plate
 - Mounting in other cabinet areas, taking the permissible DRIVE-CLiQ cable lengths into account

Configuration (continued)

Configuration of a drive group in chassis format

- The Motor Modules must be positioned to the left or right of the Line Module with decreasing rated currents (i.e. the Motor Module with the highest rated current is positioned next to the Line Module, while the Motor Module with the lowest rated current is at the end on the left or right). You must ensure that the cables/busbars for the DC link meet the current-carrying capacity requirements for all connected Motor Modules.
- The inductance of the DC link busbars must be low, achieved, for example, by arranging the bars as close as possible in parallel, but observing the required creepage distances and air gaps.
- The Control Unit configuration is flexible. The following configuration options are possible:
 - "Docking" on the left-hand side of the Line Module
 - Direct mounting next to the drive group on a mounting plate
 - Mounting in other cabinet areas, taking the permissible DRIVE-CLiQ cable lengths into account

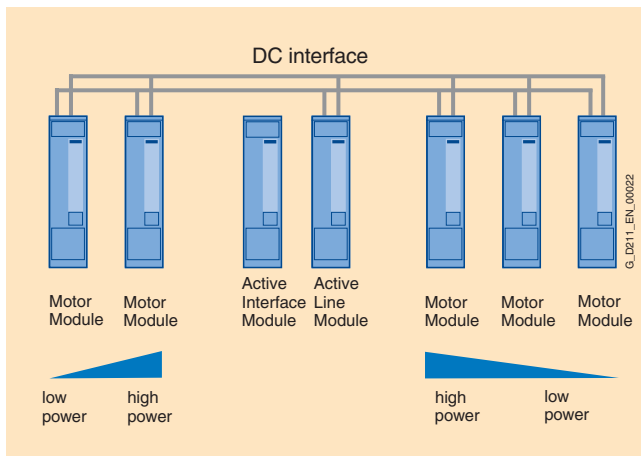

Configuration of a mixed drive group in chassis and book-size formats

A mixed drive group must be configured according to the rules for chassis format units. The Motor Modules in booksize format can be connected to the higher-level DC link busbars by means of DC link power supply adapters. There are two possible connection options - A and B. With A, each Motor Module in booksize format is connected using the appropriate DC link power supply adapter. With B, Motor Modules in booksize format are connected to one another and the internal DC link busbars and a DC link power supply adapter is used on the last Motor Module to make the connection to the higher-level DC link busbars. In the latter case, the DC link power supply adapter must be attached to the last Motor Module on the right-hand side of the line. As regards the arrangement of modules with different current ratings, the guidelines specified under "Configuration of a drive group in booksize format" also apply to mixed drive groups.

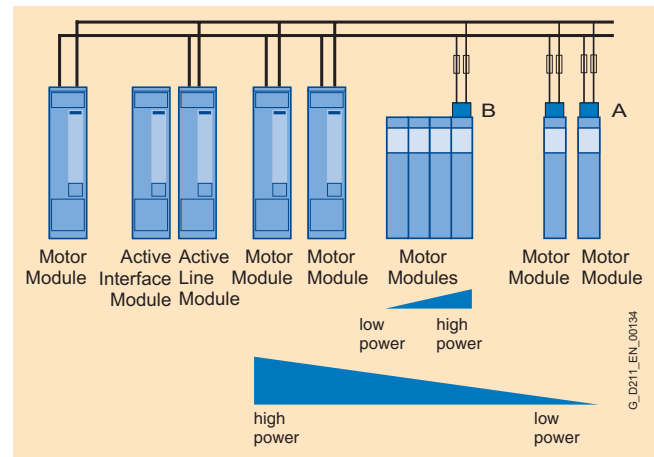

Ideally, the entire length of the higher-level DC link busbars can be dimensioned for the rated DC link current of the Line Module. The busbars are then protected by the line fuses at the infeed end.

If the cross section of the DC link busbars or cabling is reduced, this branch must be designed to be short-circuit-proof. The current limiting mechanism of the Motor Modules connected to the branch with reduced cross section then protects it against overloading. It is not advisable to reduce busbars or cables down to the mandatory minimum cross section. No additional overload protection (fuse) is required on the assumption that overloading cannot occur as a result of cable damage on the cable route to the Motor Module and that the circuit branch is protected against overloading by the Motor Module.

Where the cross section has been significantly reduced, or the circuit design is not inherently short-circuit-proof, a branch fuse must be installed at the beginning of the section with reduced cross section in order to protect the DC link connections involved. In the event of a fault, the fuse must be capable of interrupting DC fault currents; other types of miniature circuit-breaker are not suitable.

Further information

System description

Mechanical installation of the drive system

Configuration (continued)

Allocation of branch fuses for option (A) in a supply system with grounded neutral (TN system). The calculations are based on the assumption that $\tau = L/R < 10$ ms applies to the time constant τ in the DC fault circuit and that the fault current is interrupted by the fuse after maximum 1 s.

Motor Module booksize format I_{rated}	DC link supply adapter	Branch fuse (SITOR protection of semi- conductors fuse)	A	Recommended cable cross section for Cu conductors and PVC insulation with a permissible operating temperature of 70 °C (158 °F) on the conductor
	Order No.	Order No.		mm ²
A				
3	6SL3162-2BD00-0AA0	3NE1813-0	16	2.5
5		3NE1813-0	16	2.5
9		3NE1803-0	35	4
18		3NE1818-0	63	10
30		3NE1820-0	80	10
45	6SL3162-2BM00-AA0	3NE1022-0	125	35
60		3NE1224-0	160	70
85		3NE1225-0	200	95
132		3NE1230-0	315	95
200		3NE1332-0	400	95
2 × 3	6SL3162-2BD00-0AA0	3NE1814-0	20	2.5
2 × 5		3NE1803-0	35	4
2 × 9		3NE1818-0	63	10
2 × 18		3NE1022-0	125	10

Heat dissipation

Mandatory minimum installation clearances

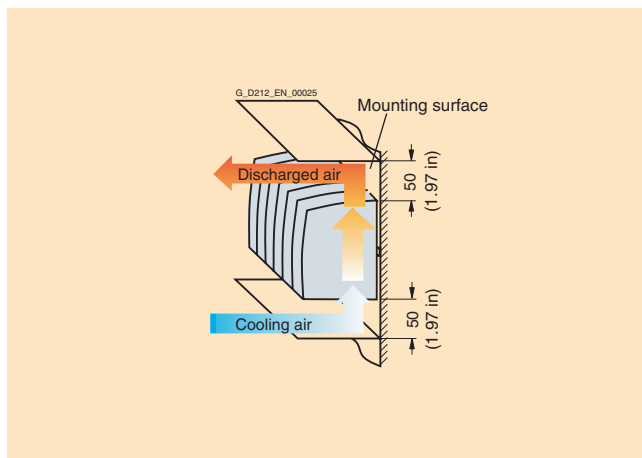

Ventilation clearances for Sensor Modules and Terminal Modules

Sensor Modules and Terminal Modules can be mounted directly adjacent to one another.

- When mounted on the wall, line reactors and line filters require a ventilation space of 100 mm (3.94 inch) above and below respectively.

Ventilation clearances for blocksize format components

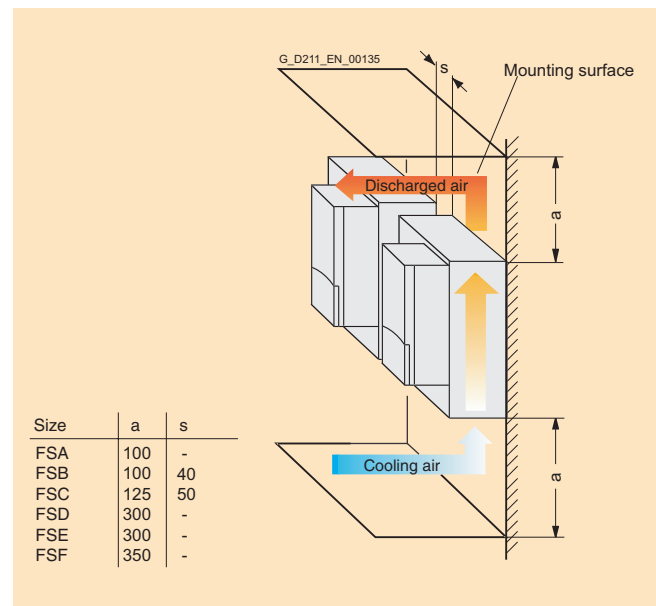

In lines of adjacent modules, a minimum side clearance between Power Modules must be maintained for certain frame sizes. Power Modules of frame sizes FSA, FSD, FSE and FSF can be mounted directly adjacent to one another.

Configuration (continued)

Ventilation clearances for booksize format components

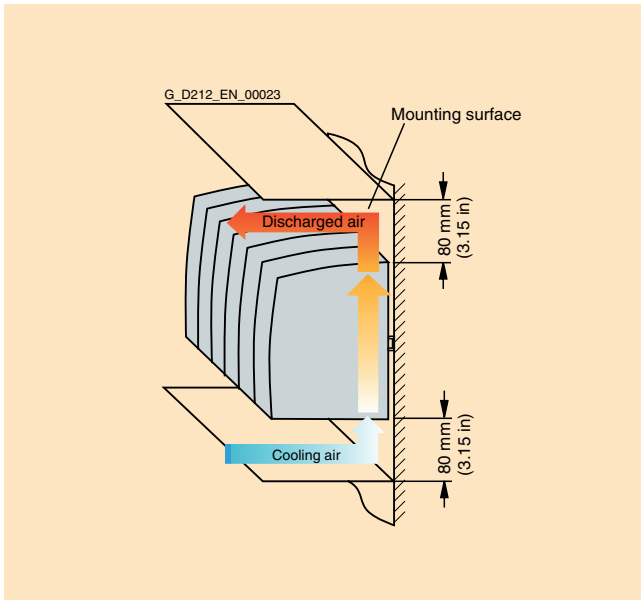

Ventilation clearances for chassis format components

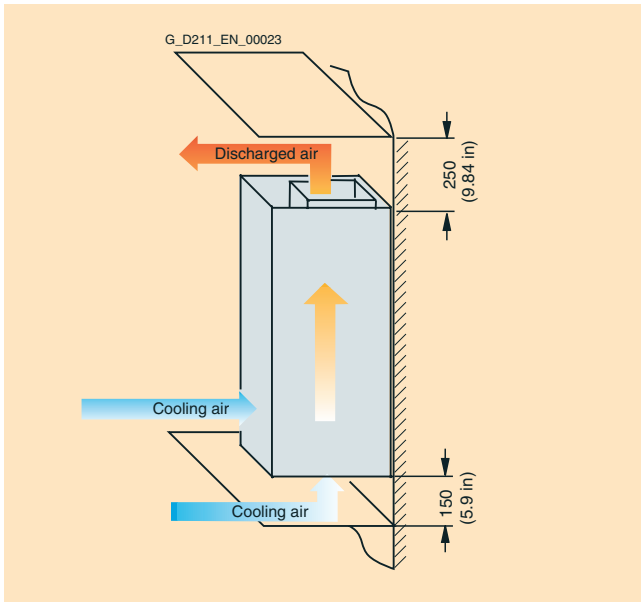

Basic Line Modules

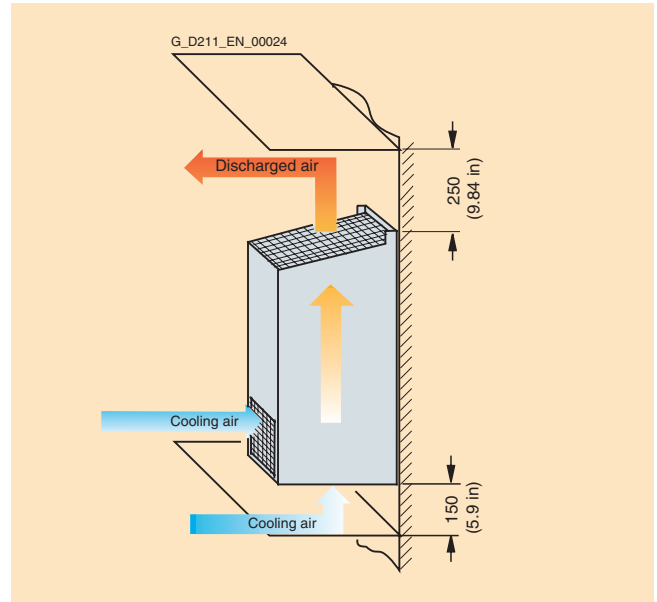

Active Interface Modules types FI and GI

Further information

System description

Mechanical installation of the drive system

Configuration (continued)

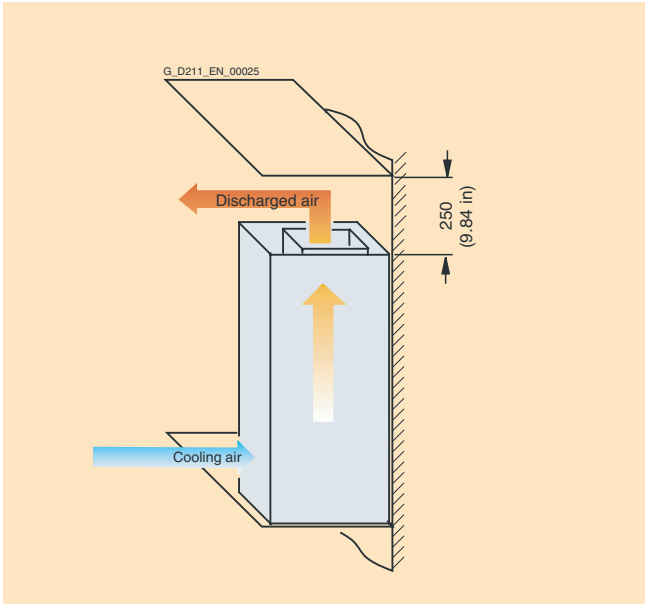

Active Interface Modules in frame sizes HI and JI

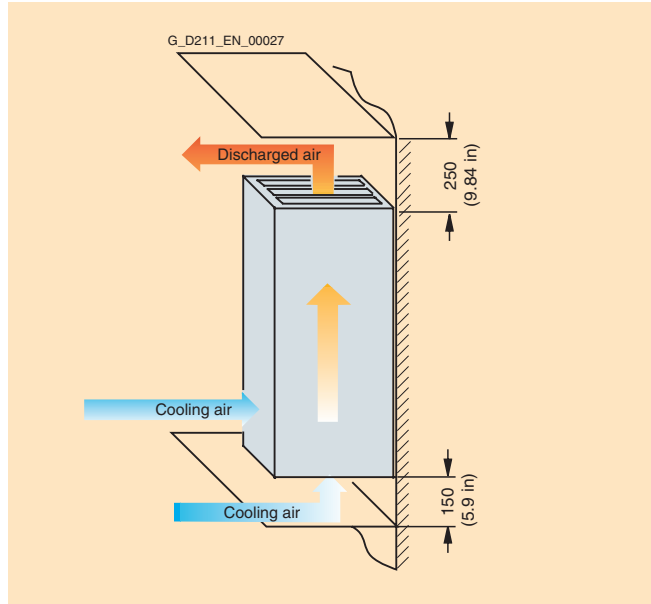

Active Line Modules in frame sizes HX and JX
Motor Modules in frame sizes HX and JX

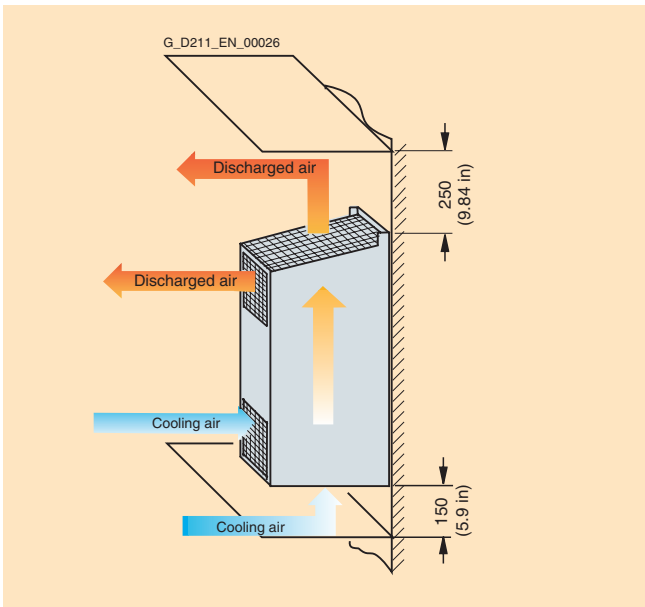

Power Modules, Motor Modules and Active Line Modules in frame sizes FX and GX

6

Services and documentation

7



7/2	Applications
7/2	Application centers
7/2	Advice on applications and implementation
7/2	On-site application training
7/3	Training
7/4	Training package for the SINAMICS S120
7/4	Training course SINAMICS S120
7/5	Training case
7/7	SINAMICS S120 training case
7/8	SIMOTION D upgrade kit
7/9	SIMOTION D435 training case
7/10	ASM asynchronous (induction) motor training case
7/11	Service & Support
7/12	Documentation

Overview



We base our understanding of an application on a customer-specific solution of automation or motion control task based on standard hardware and software components. In this respect, industry knowledge and technological expertise are just as important as expert knowledge about how our products and systems work. We are set for this challenge with more than 130 application engineers at 14 locations in 8 countries in various parts of the world.

Application centers

We currently have application centers in:

- Germany: Chemnitz, Erlangen, Cologne, Mannheim, Stuttgart
- Italy: Bologna, Milan
- USA: Atlanta
- China: Beijing
- France: Paris
- Turkey: Istanbul
- India: Mumbai
- Switzerland: Zurich

Other application centers are under construction.

These application centers specialize in the use of SIMOTION/SINAMICS. You can, therefore, rely on automation, motion and drive specialists for implementing successful applications. By involving your personnel at an early stage in the process, we can provide a solid basis for rapid knowledge transfer, maintenance and further development of your automation solution.

Advice on applications and implementation

We offer a variety of consultation services to help you find the optimum solution for the SIMOTION/SINAMICS application you want to implement.

The quotation phase includes

- clarification of technical questions
- discussion of machine concepts and customer-specific solutions
- selection of suitable technology
- suggestions for implementation.

A technical feasibility study is also performed at the outset. In this way, difficult points of the application can be identified and solved early on. We can also configure and implement your application as a complete solution (including control cabinets) from a single source.

During the implementation phase a number of proven standards can be applied. This saves engineering costs.

The system can be commissioned by experienced, competent personnel, if required. This saves time and ensure correctness.

If servicing is required, we can support you on site or via teleservice. For more information about servicing, please see "Service and Support".

On-site application training

Training for the implemented applications can be organized and carried out on site. This training for machine manufacturers and their customers does not deal with individual products, but the entire hardware and software system (for example automation, drives and visualization).

From an initial concept to successful installation and commissioning:

We can provide complete support for SIMOTION/SINAMICS! Contact your Siemens representative.

For more information, go to:

<http://www.siemens.com/motioncontrol/apc>

Overview



Because training is the key to your success

SITRAIN® – Siemens training for automation and industrial solutions – will be constantly by your side to help you find solutions for your tasks.

With training provided by the market leader in automation, plant installation and support, you can have complete confidence in any decisions you make, in particular concerning the optimum use of products and the efficient running of systems. You can rectify deficits in existing systems and rule out expensive planning errors right from the start.

All in all, this is a massive plus for your company, as you will benefit in terms of shorter start-up times, optimized plant sections, faster troubleshooting and reduced downtimes. The result? Profits go up and costs come down.

■ **Top trainers**

Our trainers are skilled specialists with extensive experience of training provision. The designers of our courses are directly involved in product development and forward their knowledge directly to our trainers.

■ **A firm basis in practice**

As our trainers have direct experience of practical applications, they are able to render their theoretical knowledge with real plausibility. However, as we all know that any theory has its gray areas, we prioritize practical exercises, and allocate up to half of the course program to them. This means that you can apply what you have learned immediately in everyday activities. We use state-of-the-art customized training equipment. Once you have completed your training with us, you will feel ready for anything.

■ **Training variety**

With a total of some 300 participant-based courses, we can provide training for the entire range of products and a large number of system solutions. Remote learning services, self-teach software and moderated online seminars complement our traditional training offer.

■ **Customer proximity**

We are never very far away. We have approximately 60 locations in Germany and a presence in 62 countries all over the world. Would you prefer individual training to taking part in one of our 300 courses? Our solution: we can customize our program to meet your personal requirements. Training takes place in our training centers or on your site.

The ideal combination: Blended learning

Blended learning combines a variety of teaching media and sequences. For example, a participant-based course in a training center can be ideally combined with self-teach programs prior to or following completion. SITRAIN also uses moderated online learning to provide training live on the Internet at agreed times.

The combination is the key, because blended learning is able to communicate complex subjects and transfer knowledge on a networked basis. Additional benefits: travel expenses and downtimes are reduced as training is no longer restricted to a specific time and place.

The international learning portal

For more information, go to:
<http://www.siemens.com/sitrain>

All your learning options at a glance! Take your time to browse our international training package, call up all course dates online, use the available places indicator (updated daily) - and apply directly.

Alternatively, contact us directly for personal advice:

Training Office, Infoline Germany
Phone: +49 (0) 18 05 23- 56 11
Fax: +49 (0) 18 05 23 - 56 12

Training Office, US
Phone: +1 800 241 4453

sitrain.registrar.sea@siemens.com

... and request a copy of our latest training catalog:

	Language	Order No.
ITC Catalog (paper version)	German	E86060-K6850-A101-B6
List of dates and prices including CD-ROM	German	E86060-P6850-A101-D2
Interactive training information system SITRAIN on CD-ROM	English/ German	E86060-D6850-A100-C4-7400

Further information

Services and documentation

Training

Design

Training package for the SINAMICS S120 drive system

This provides an overview of the training available for the SINAMICS S120 drive system.

The courses are modular in design and are intended for a variety of target groups as well as individual customer requirements.

The system overview will acquaint decision-makers and sales personnel with the system very quickly.

The planning course provides all the information you need to set up the drive system.

The basic and follow-up courses are sure to provide all the technical knowledge service engineers will need for servicing/ commissioning motion control applications, communication and cabinet-mounted units.

All courses contain as many practical exercises as possible, in order to enable intensive and direct training on the drive system and with the tools in small groups.

Title	Target group							Duration	Course code
	Decision-makers, sales personnel	Project managers, project assistants	Programmers	Commissioning engineers, configuring engineers	Service personnel	Maintenance personnel			
Basic courses									
SINAMICS system overview	✓	✓						2 days	DR-SN-UEB
SINAMICS S120 configuration and planning	✓	✓	✓					5 days	DR-SNS-PRJ
SINAMICS S120 service and commissioning			✓	✓	✓	✓		5 days	DR-SNS-SI
Follow-up courses									
SINAMICS communication			✓	✓	✓			3 days	DR-SN-COM
SINAMICS S120 chassis unit servicing			✓	✓	✓			2 days	DR-SNS-CHA
SINAMICS S120 on SIMOTION and T CPU				✓	✓			4 days	DR-SNS-MC
Commissioning SINAMICS S120 with SINUMERIK solution line			✓	✓	✓			3 days	DR-SNS-SL

Training course SINAMICS S120

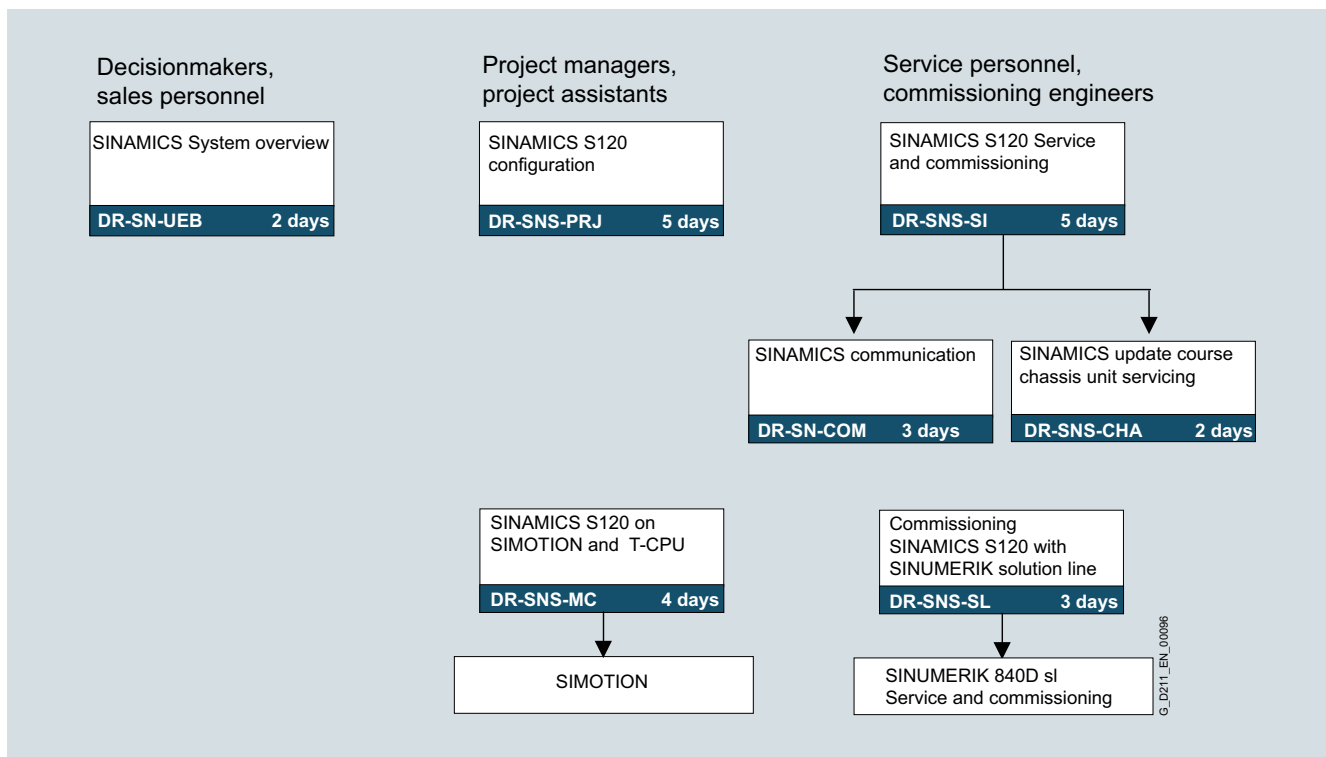

G_D211_EN_00096

Description

SINAMICS system overview **DR-SN-UEB** **2 days**

Description/learning target

This course has been specially designed for sales employees and decision-makers who wish to attain a rapid overview of the SINAMICS drive concept and its position in the existing Siemens drive environment.

The system overview is supplemented by an introduction to the fundamentals of motor and converter technology.

The SIZER configuration tool and the STARTER commissioning tool are presented and explained using short exercises.

Target group

Decision-makers and sales personnel

Content

- SINAMICS system overview
- Position with respect to existing drive systems
- Fundamentals of converter engineering and motors
- SIZER configuration tool
- STARTER commissioning tool
- Simple drive commissioning
- Practical exercises using the training case

SINAMICS S120 configuration and planning course **DR-SNS-PRJ** **5 days**

Description/learning target

The course is designed for design engineers, configuring engineers and sales personnel responsible for the configuration and planning of drive systems with SINAMICS S120.

Building on the SINAMICS system overview, the fundamental interrelationships for setting up a drive system are explained. The self-explanatory SIZER configuration tool is used to calculate various applications of SINAMICS S120 and demonstrate them in more detail by means of PC-based exercises. The technical documentation provides an overview of the parameter structure and essential software functions.

The STARTER commissioning tool is used to demonstrate a simple commissioning application on the SINAMICS S120 training case.

Target group

Decision-makers, sales personnel, project managers, project personnel, programmers

Content

- SINAMICS system overview
- Range of motors for SINAMICS S120
- Configuration of the SINAMICS S120 drive system and fundamentals
- SIZER configuration tool with example exercises and calculations
- Technical documentation: Catalogs, Planning Guides, Operating Instructions
- Overview of functions and parameters
- Simple commissioning with the STARTER commissioning tool

SINAMICS S120 service/commissioning course **DR-SNS-SI** **5 days**

Description/learning target

This course provides basic training for the SINAMICS S120 drive system.

It provides the technical knowledge required for commissioning, parameterization and troubleshooting.

The course begins with a general explanation of the drive system's hardware and documentation and progresses to detailed training on commissioning and diagnostics with the STARTER commissioning tool and handling instructions for the CompactFlash card.

Other key focal points are signal interconnections, software functions and controller structures of the Servo and Vector operating types. The drive is optimized with the tracer of the STARTER commissioning tool. Practical, knowledge-building exercises are performed using the SINAMICS S120 training cases in booksize format with synchronous servo motors and standard asynchronous (induction) motors. There is also an introduction to PROFIBUS communication, which can be expanded on in the follow-up course DR-SN-COM. Users who wish to learn how to service SINAMICS S120 chassis units should complete the follow-up course DR-SNS-CHA.

Target group

Programmers, commissioning engineers, configuring engineers, service personnel and maintenance personnel

Content

- Design of the drive system
- Overview of documentation and servicing
- Commissioning and parameterization with the STARTER commissioning tool
- Diagnostics and troubleshooting
- Fundamentals of communication via PROFIBUS
- Software functions, closed-loop control and optimization of servo and vector drives
- Introduction to integration in SIMOTION using the SCOUT tool
- Practical exercises using the training case

Description (continued)

SINAMICS communication **DR-SN-COM** **3 days**

Description/learning target

The course is appropriate for programmers and service engineers who, as an extension to the DR-SNS-SI course, require further knowledge of the PROFIBUS and RS232 communications interfaces for STARTER and AOP30, as well as I/O terminals.

The focal point is PROFIBUS with the PROFIDrive V3 profile with routing, teleservice, and the functionalities associated with the isochronous bus cycle, isochronous mode with servo applications, and direct OP access. Also described are the libraries of DriveES SIMATIC for cyclic and acyclic data exchange.

This knowledge is expanded by practical exercises using SINAMICS and SIMATIC S7 training cases with CPU 315-2 DP.

Target group

Programmers, commissioning engineers, configuring engineers, service personnel

Content

- Overview of the PROFIBUS DP, RS232-PPI, CAN and I/O terminals: function, topology, parameterization
- Fundamentals of PROFIBUS with the PROFIDrive V3 profile
- Basic functions on the PROFIBUS: routing, teleservice and direct access
- PROFIBUS for motion control with: isochronous bus cycle and isochronous mode with Servo control
- Cyclic and acyclic data exchange with DriveES SIMATIC components
- Drive fault diagnostics using the bus system
- Practical exercises on the SINAMICS S120 and SIMATIC S7 training cases with CPU 315-2 DP

SINAMICS S120 follow-up course on chassis unit servicing **DR-SNS-CHA** **2 days**

Description/learning target

Building on the knowledge gained in the basic course DR-SNS-SI, this course teaches the special skills required to service and maintain SINAMICS S120 chassis units. Focal training points are design, diagnostics and replacement of components on power units for advanced servicing tasks. The special modular design features of different Line Modules and Motor Modules are also explained and participants are introduced to the modular SINAMICS S120 cabinet system. Practical exercises are carried out on SINAMICS chassis units.

Target group

Programmers, commissioning engineers, configuring engineers, service personnel

Content

- Design and technical documentation of chassis units
- Installation, electrical connection, EMC
- Diagnostics on the power unit using the SINAMICS test box and replacement of spare parts
- Practical diagnostics exercises

SINAMICS S120 on SIMOTION and T-CPU **DR-SNS-MC** **4 days**

Description/learning target

The course is designed for users of SINAMICS S120 drives in conjunction with SIMOTION and/or SIMATIC T CPU motion control systems.

The course starts with an introduction to the SIMOTION and SIMATIC T CPU controllers and an overview of the SINAMICS S120 drive system's hardware and documentation before describing the software functions, parameter structure and function charts for motion control applications. It provides the technical knowledge required for commissioning, parameterization and troubleshooting.

Even more detailed information is provided in the form of practical exercises on the training cases and the SCOUT, T Config and STARTER integrated commissioning tools.

Target group

Commissioning engineers, configuring engineers, service personnel

Content

- Brief introduction to SIMOTION and SIMATIC T CPU motion control controllers using two sample projects
- Overview of the SINAMICS S120 drive system
- Commissioning and parameterizing SINAMICS drives with the SCOUT and T Config tools
- Description of the SINAMICS controller structure for motion control applications with DSC
- Parameterization, optimization and diagnostics with the integrated STARTER functions
- Practical exercises on the SIMOTION D, SINAMICS S120 and SIMATIC T CPU training cases

Commissioning SINAMICS S120 with SINUMERIK **solution line** **DR-SNS-SL** **3 days**

Description/learning target

This course teaches participants how to commission and service combined SINAMICS S120 / SINUMERIK 840D sl systems. On completing the course, participants will be capable of commissioning drives. Their understanding of the different functions will enable them to coordinate the drive and driven machine perfectly, thereby achieving excellent machine productivity. Participants will also be capable of selective troubleshooting and fault rectification. They will understand how the SINUMERIK and SINAMICS systems interact and therefore be capable of achieving the best performance from the system functions.

Target group

Programmers, commissioning engineers, configuring engineers, service personnel

Content

- Function and application of SINAMICS S120 Modules
- Mechanical and electrical device concept
- Overview of suitable motors
- Controller structure of main spindle and feed drives
- Commissioning of feed axes and main spindle in conjunction with SINUMERIK 840D sl
- Frequency response analysis for drive optimization
- Handling and parameterization of drive machine data
- Commissioning and troubleshooting exercises

Application



This case is used for training purposes and product demonstrations of the SINAMICS S120 drive system.

It can also be used for test purposes in the laboratory and as a drive for the SIMOTION motion control system. The SIMOTION D435 upgrade kit can be used to convert the SINAMICS S120 training case to a SIMOTION D training case.

Design

- Case optimized in terms of weight and volume
- Set up complete with transport wheels and ready for connection
- Supply voltage 230 V 1 AC or via line adapter 115 V 1 AC (USA)
- Regenerative feedback not possible
- Drive system comprising of:
 - CU320 Control Unit with TB30 Terminal Board
 - Smart Line Module, 5 kW
 - Single/Double Motor Module, 3 A
 - 1 synchronous motor 1FK7022-5AK71-1AG0 with incremental encoder sin/cos 1 V_{pp} 2048 pulses/revolution
 - 1 synchronous motor 1FK7022-5AK71-1LG0 with absolute encoder EnDat 512 pulses/revolution and DRIVE-CLiQ interface
 - Reference loops for position monitoring
- Control box for setpoint/actual-value linkage via terminals
- Prefabricated connection option for an external motor, e.g., asynchronous motor (induction motor)

The training case is supplied ready-to-use with a demo project on the CompactFlash card and documentation.

Technical specifications

SINAMICS S120 training case

Input voltages	230 V 1 AC
Degree of protection in accordance with DIN VDE 0470 Part 1/ EN 60529/IEC 529	IP00
Dimensions (W × H × D)	320 × 650 × 330 mm 12.6 × 25.6 × 13 inch
Weight, approx.	30 kg 66 lb

Selection and Ordering Data

	Order No.
SINAMICS S120 training case TK-SIN-CU320 with CU320, demo project on CompactFlash card and control box	
• Single-axis version with 1FK7 motor	6ZB2480-0AA00
• 2-axis version with 1FK7 motors	6ZB2480-0BA00
Line adapter 115 V 1 AC/230 V 1 AC	6AG1064-1AA02-0AA0
Control box SINAMICS (if ordered separately)	6AG1064-1AA01-0AA0

More information

The SINAMICS S120 training case can be expanded by the asynchronous (induction) motor training case, as well as the SIMOTION D435 upgrade kit.

SIMOTION D435 upgrade kit

Application



The SIMOTION D435 upgrade kit is designed for easy conversion of the SINAMICS S120 training case for teaching how to use and understand the SIMOTION D motion control system. It is also suitable for use for test purposes in the laboratory.

An HMI operator control and monitoring training case is available for SIMOTION D, comprising of a panel and a remote ET 200M I/O module, to which a simulation module is connected. Alternatively, the HMI can be simulated with a PC/PG.

Design

The upgrade kit comprises of:

- SIMOTION D435 Control Unit
- CompactFlash card with demo project and license for technology package
- Documentation

The HMI training case comprises of:

- An operator panel
- An ET 200M distributed I/O module with simulation module

Selection and Ordering Data

	Order No.
SIMOTION D435 upgrade kit for TK-SIN-CU320 with demo project on CompactFlash card	6ZB2470-0AH00
HMI case for SIMOTION D435 with ET 200 and OP	6ZB2470-0AG00

Application



For pure SIMOTION D applications, the SINAMICS S120 case is supplied with the D435 Control Unit.

This case is used for training purposes and product demonstrations of the SIMOTION D motion control system. It is also suitable for use for test purposes in the laboratory.

Design

- Case optimized in terms of weight and volume
- Set up complete with transport wheels and ready for connection
- Supply voltage 230 V 1 AC or via line adapter 115 V 1 AC (USA)
- Regenerative feedback not possible
- Drive system comprising of:
 - SIMOTION D435 controller with TB30 Terminal Board
 - Smart Line Module, 5 kW
 - Double Motor Module, 3 A
 - 1 synchronous motor 1FK7022-5AK71-1AG0 with incremental encoder sin/cos 1 V_{pp} 2048 pulses/revolution
 - 1 synchronous motor 1FK7022-5AK71-1LG0 with absolute encoder EnDat 512 pulses/revolution and DRIVE-CLiQ interface
 - Reference loops for position monitoring
- Control box for setpoint/actual-value linkage via terminals
- Prefabricated connection option for an external motor, e.g. asynchronous motor (induction motor).

The training case is supplied ready-to-use with a demo project and technology package license on the CompactFlash card including documentation.

Technical specifications

SIMOTION D training case	
Input voltages	230 V 1 AC
Degree of protection to DIN VDE 0470 Part 1/ EN 60529/IEC 529	IP00
Approx. weight	34 kg 75 lb
Dimensions (W × H × D)	320 × 650 × 330 mm 12.6 × 25.6 × 13 inch

Selection and Ordering Data

	Order No.
SIMOTION D435 training case TK-SIM-D435	6ZB2470-0AE00
with control box, demo project on CompactFlash card and license for technology package	

Further information Services and documentation

ASM asynchronous (induction) motor training case

Application



The ASM training case is available as an add-on unit to the SINAMICS S120 training case for applications with asynchronous motors (induction motors). Both training cases are used in combination for training purposes and product demonstrations of the SINAMICS S120 Vector Control drive system and in conjunction with the AOP30 to simulate SINAMICS cabinet units.

It is also suitable for use for test purposes in the laboratory.

Design

- Standard asynchronous (induction) motor 1LA7060-2AA10 with KTY temperature sensor and HTL incremental encoder
- SMC30 Sensor Module Cabinet-Mounted for encoder connection via DRIVE-CLiQ
- 24 V DC connecting cable for SMC30
- External torque by means of controllable mechanical brake

Technical specifications

ASM training case	
Input voltages	24 V DC
Degree of protection in accordance with DIN VDE 0470 Part 1/ EN 60529/IEC 529	IP00
Dimensions (W × H × D)	377 × 210 × 277 mm 14.8 × 8.3 × 10.9 inch
Weight, approx.	12 kg 26.5 lb

Selection and Ordering Data

	Order No.
ASM training case TG-SN-ASM	6ZB2480-0CB00



In the face of harsh competition you need optimum conditions to keep ahead all the time:

a strong starting position, a sophisticated strategy and team for the necessary support – in every phase.

Service & Support from Siemens provides this support with a complete range of different services for automation and drives.

In every phase: from planning and commissioning to maintenance and upgrading.

Our specialists know when and where to act to keep the productivity and cost-effectiveness of your system running in top form.

Online Support



The comprehensive information system available round the clock via Internet ranging from Product Support and Service & Support services to Support Tools in the Shop.

<http://www.siemens.com/automation/service&support>

Technical Support



Competent consulting in technical questions covering a wide range of customer-oriented services for all our products and systems.

Phone: +49 (0)180 50 50 222
Fax: +49 (0)180 50 50 223
E-Mail:
adsupport@siemens.com

In Canada, call:
Phone: +1 888 303 3353
E-Mail: cic@siemens.ca

In the United States, call toll-free:
Phone: +1 800 333 7421,
Fax: +1 423 262 2200
E-Mail: techsupport.sea@siemens.com

In Asia:
Phone: +86 10 6475 7575,
Fax: +86 10 6474 7474
E-Mail:
adsupport.asia@siemens.com

Technical Consulting

Support in the planning and designing of your project from detailed actual-state analysis, target definition and consul-

ting on product and system questions right to the creation of the automation solution. ¹⁾

Optimization and Upgrading

To enhance productivity and save costs in your project we

offer high-quality services in optimization and upgrading. ¹⁾

Configuration and Software Engineering:



Support in configuring and developing with customer-oriented services from actual configuration to implementation of the automation project. ¹⁾

Service On Site:



With Service On Site we offer services for startup and maintenance, essential for ensuring system availability.

In Germany
Phone: 0180 50 50 444 ¹⁾

In the United States, call toll-free:

Phone: +1 800 333 7421

In Canada, call:

Phone: +1 888 303 3353

Repairs and Spare Parts



In the operating phase of a machine or automation system we provide a comprehensive repair and spare parts service ensuring the highest degree of operating safety and reliability.

In Germany
Phone: 0180 50 50 448 ¹⁾

In the United States, call toll-free:

Phone: +1 800 241 4453

In Canada, call:

Phone: +1 888 303 3353

SPARESonWeb - Online spare parts catalog

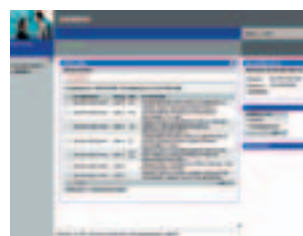

SPARESonWeb is a web-based tool for selecting the spare parts available for the SINAMICS system. After you have registered and entered the serial number and order number, the spare parts available for the relevant unit are displayed.

The delivery state for specific orders can be displayed for all shipped SINAMICS products.

<http://workplace.automation.siemens.de/sparesonweb>

Product registration

To guarantee our servicing performance (availability of spare parts, hotline function, readiness of personnel), we offer you product registration for our SINAMICS drive equipment. Feedback on the final position (installation/operation location) and naming of contact partners allow a servicing response without delay. The feedback can be made either using a feedback form (enclosed with each converter) or over the Internet:

<http://www.siemens.com/reg>

¹⁾ For country-specific telephone numbers go to our Internet site at: <http://www.siemens.com/automation/service&support>

Further information

Services and documentation

Documentation

Overview

The documentation is clearly divided into a number of manuals. The manuals must be ordered separately (in the required language and quantities) from the actual equipment.

Information is available in the following formats:

- **Paper version**, printed copy
- **PDF file** available on Internet as DOConWEB – application with 'search all documents' function
<http://www.siemens.com/automation/doconweb>

The following manuals are available:

- **Equipment Manual/Planning Guide**
containing all necessary information about the intended use of the components of a system, e.g., technical specifications, interfaces, dimension drawings, characteristic curves and possible applications.
The Equipment Manual/Planning Guide is intended for use during the following phases: cabinet configuration/setup, circuit diagram configuration/drawing.
- **Commissioning Manual**
containing all information relevant to commissioning after installation and wiring. It also contains all safety and warning notices relevant to commissioning in addition to overview drawings.
The Commissioning Manual is intended for use during the following phases: commissioning of components that have already been connected, configuration of system functions.

- **List Manual**
containing all parameters, function charts, and faults/warnings for the product/system, as well as their meanings and setting options. It contains parameter data, descriptions of faults/warnings and how they affect functions.
The List Manual is intended for use during the following phases: commissioning of components that have already been connected, configuration of system functions, fault cause/diagnostics.
- **Getting Started**
providing information about getting started for the first-time user, as well as references to additional information. It contains information about the basic steps to be taken during commissioning. For more advanced operations, see the information in other documentation.
Getting Started is intended for use during the following phases: commissioning of components that have already been connected.
- **Function Manual Drive Functions**
containing all the relevant information about individual drive functions: description, commissioning and integration in the drive system.
The Function Manual is intended for use during the following phases: commissioning of components that have already been connected, configuration of system functions.
- **DOConCD**
DOConCD is a CD-ROM containing manufacturer and service documentation for the SINAMICS motors and drive systems.

For more information about the availability of publications, go to <http://www.siemens.com/motioncontrol> and select pages → Support → Technical Documentation → Publications Overview.

Selection and Ordering Data

Description	Order No.	Order No.
	German edition	English edition
SINAMICS S120		
Equipment Manual for Control Units and Additional System Components	6SL3097-2AH00-0AP3	6SL3097-2AH00-0BP3
Equipment Manual for Booksize Power Units	6SL3097-2AC00-0AP3	6SL3097-2AC00-0BP3
Equipment Manual for Power Units Booksize Cold-Plate	6SL3097-2AJ00-0AP3	6SL3097-2AJ00-0BP3
Equipment Manual for Chassis Power Units	6SL3097-2AE00-0AP1	6SL3097-2AE00-0BP1
Equipment Manual AC Drive	6SL3097-2AL00-0AP0	6SL3097-2AL00-0BP0
Commissioning Manual	6SL3097-2AF00-0AP3	6SL3097-2AF00-0BP3
SINAMICS S List Manual	6SL3097-2AP00-0AP4	6SL3097-2AP00-0BP4
Getting Started	6SL3097-2AG00-0AP2	6SL3097-2AG00-0BP2
Function Manual Drive Functions	6SL3097-2AB00-0AP3	6SL3097-2AB00-0BP3
DOConCD, The SINAMICS System (English/German)	6SL3097-2CA00-0YG3	
Motors		
General Section for Three-Phase Asynchronous (Induction) Motors	6SN1197-0AC62-0AP0	6SN1197-0AC62-0BP0
Planning Guide for 1PH7 Motors	6SN1197-0AC71-0AP0	6SN1197-0AC71-0BP0
Planning Guide for 1PL6 Motors	6SN1197-0AC67-0AP1	6SN1197-0AC67-0BP1
Planning Guide for 1PH4 Motors	6SN1197-0AC64-0AP1	6SN1197-0AC64-0BP1
General Section for Synchronous Motors	6SN1197-0AD07-0AP4	6SN1197-0AD07-0BP4
Planning Guide for 1FT6 Motors	6SN1197-0AD12-0AP0	6SN1197-0AD12-0BP0
Planning Guide for 1FK7 Motors	6SN1197-0AD16-0AP1	6SN1197-0AD16-0BP1
Planning Guide for 1FS6 Motors	6SN1197-0AD08-0AP0	6SN1197-0AD08-0BP0
Planning Guide for 1FW3 Motors	6SN1197-0AD70-0AP0	6SN1197-0AD70-0BP0

The SINAMICS S List Manual and the Motor Planning Guides are also available in the following languages:

French: ...-ODP.

Italian: ...-0CP.

Spanish: ...-0EP.

Replace the third to last letter in the order number with the corresponding letter.





8/2	Glossary
8/9	CAD CREATOR Dimension sheet and 2D/3D CAD generator
8/10	Siemens Contacts Worldwide
8/11	A&D online services
8/11	A&D in the WWW
8/11	Product Selection Using the Offline Mall of Automation and Drives
8/11	Easy Shopping with the A&D Mall
8/12	Subject Index
8/14	Order Number Index
8/17	Suggestions for improvement to the catalog Fax form
8/18	Conversion Tables
8/20	Conditions of sale and delivery
8/21	Metal surcharges

Glossary

Absolute encoder

After switching on the power supply voltage, this position encoder immediately provides the position of the drives as an absolute actual value. For single-turn encoders, the detection range is one turn, whereas multi-turn encoders have a detection range of several turns (a typical number is e. g. 4096 turns). If an absolute encoder is used as position encoder, no homing procedure is required after the switch-on and the reference switch (e.g. BERO) which could normally be required is not necessary in this case.

There are rotary and linear absolute encoders.

Example of an absolute encoder:

1FK and 1FT6 motors can be delivered with integrated multi-turn absolute encoders with 2048 sinusoidal/cosinusoidal signals per turn, over 4096 turns absolute and → "EnDat protocol".

Active Infeed

Overall functionality of an infeed with → "Active Line Module" including the required additional components (filters, switching devices, computing power portion of a → "Control Unit", voltage detection, etc.).

Active Interface Module

This module includes the line-side components required for an → "Active Line Module" like, for example, the pre-charging circuit (pre-charging contactors and buffer protection).

Active Line Module

This controlled, self-commutating feed/feedback unit (with IGBTs infeed/feedback device) supplies a constant DC link voltage for the → "Motor Modules". The Active Line Module co-operates with the → "line reactor" as a step-up converter.

Asynchronous (induction) motor

The asynchronous (induction) motor is an AC motor whose speed runs "behind" the synchronous speed.

Asynchronous motors can be connected to the three-phase system either directly in a star or delta connection or via a converter.

In combination with a converter, the asynchronous motor becomes a "variable-speed drive system".

Further, generally used terms: squirrel-cage induction motor, squirrel-cage motor.

See → "synchronous motor"

Automatic restart

Upon power recovery after a mains failure, the "automatic restart" function switches a converter automatically ON without requiring an acknowledgement of the power failure error. The automatic restart function e.g. minimizes drive standstill times and production failures.

However, operators must be aware of the danger situation which can occur when a drive recovers automatically after a longer power failure period without any operator action. If required, safe behavior in such a danger situation must be ensured by external control actions (e.g. withdrawal of the ON command).

Typical applications of the automatic restart: pump/fan/compressor drives working as single drives and often do not provide local control options. The automatic restart function is not used for coordinated drives for continuous material webs and motion control.

The following variants of this function can be set by means of parameters for SINAMICS:

- restart after a power failure if the 24 V electronic supply does not yet exist
- restart after a failure of the 24 V electronic supply
- restart after any shut down on fault

The following actions can be specified via parameters:

- only acknowledgement of the mains failure message (e.g. for multi-motor drives, DC compound)
- ON command upon expiry of the parameterized delay time
- ON command with flying restart

The number of possible restart trials within a parameterizable time can be specified.

It is also possible to activate the → "flying restart" function in addition to the automatic restart function to ensure a bumpless switching to a possibly still rotating motor.

Basic Line Module

Unregulated line infeed unit (diode bridge or thyristor bridge, without power feedback to the line) for rectifying the line voltage of the → "DC link".

Basic Operator Panel

Simple small operator panel for plugging on a SINAMICS → "Control Unit" with numeric display and some keys.

At present, BOP20 is offered within the framework of the SINAMICS product range.

Blocksize

Volume-optimized, cubic construction type of a → "Drive unit". Most commonly used for operating a → "Motor".

Booksize

Book-shape construction type of the components of a drive group appropriate for back-mounting. Designed primarily for multi-motor operation.

Braking control

Software function specifying the instant when an existing mechanical holding brake or operational brake has to be applied; either within the framework of a load cycle in the case of a momentary standstill, or in the case of a fault.

Braking Module

Electronic switch or chopper (brake chopper) which connects a → "braking resistor" with a specific pulse/pause ratio to the DC link voltage to convert regenerative (braking) energy to heat energy and to finally restrict the DC link voltage to permissible values. For SINAMICS, no braking resistor is incorporated in the braking module, but must be mounted outside the braking module.

Braking power

Regenerative power injected into the → "DC link" by one or several → "Motor Modules", e.g. when lowering a load or decelerating a motor.

See → "braking resistor"

Brake relay

Component with a 24 V relay for brake control. Brakes can be switched using this relay with a rating of DC 24 V/12 A or AC 440 V/12 A.

Braking resistor

Resistor which reduces the excess energy in the → "DC link". The resistor is connected to a → "Braking Module".

In this way, the resulting thermal loss is displaced outside the cabinet.

See → "braking power"

Capacitor Module

The module is used for increasing and buffering the DC link capacity.

It can be used for compensating a short-time power failure or for intermediate storage of the braking energy.

Chassis unit

In the higher power range chassis units are mostly used for incorporation in control panels. The components are mounted on supporting panels or frames.

Refer to → "Booksize" → "Blocksize"

Command data set

Parameter data set consisting of the binary inputs (e.g. for control commands) and the connector inputs (e.g. for setpoints).

The individual data sets are represented as indexed parameters. The changeover is performed via input signals.

The appropriate parameterization of several command data sets and the changeover of the data sets allows the optional operation of the drive with different preconfigured signal sources.

Communication board

A module for external communication e.g. → "PROFIBUS", CAN or Ethernet. It is plugged into the option slot of the → "Control Unit".

CompactFlash card

Memory card for non-volatile storing of the drive software and of the corresponding parameters. The memory card can be plugged in the → "Control Unit" from outside.

Control Supply Module

24 V power supply module for the electronic circuitry of components in a SINAMICS drive line-up.

The Control Supply Module is supplied via two inputs: the incoming supply and the → "DC link". The DC link connection ensures that the electronics power supply is buffered in the event of a power failure or voltage dip, thereby enabling emergency retraction and kinetic buffering.

Control Unit

Central control module: the feedforward and feedback control functions for several SINAMICS → "Line Modules" and/or → "Motor Modules" are implemented in this module.

DC link

The component of the converter (or converter system) that connects the input converter (rectifier) and the output converter (one or more converters).

With voltage source DC link converters like SINAMICS, a constant DC voltage is present in the DC link (rectified line voltage).

Direct position sensing system

Position encoder which is directly connected to the moved machine component (→ "external encoder") and the corresponding evaluation electronics. In the case of linear axes, it is also possible to use linear scales for this purpose.

In many cases, a direct position sensing system must be used because the → "motor encoder" for position sensing and controlling does not suit this purpose, e.g. as the elasticities and backlash in the drive are too significant.

Double Motor Module

Two motors can be connected to and operated with a Double Motor Module.

See → "Motor Module", → "Single Motor Module"

Glossary

DRIVE-CLiQ

Abbreviation of "Drive Component Link with IQ".

Communication system for connecting the various components of a SINAMICS drive system, such as the → "Control Unit", the → "Line Modules", the → "Motor Modules", the → "motors" and the speed/position encoders.

The DRIVE-CLiQ hardware is based on the Industrial Ethernet standard and uses twisted-pair lines. The DRIVE-CLiQ line provides the transmit and receive signals and also the +24 V power supply.

Drive system

A drive system includes all components of a family of products (e.g. SINAMICS) belonging to a drive. A drive system includes components such as → "Line Modules", → "Motor Modules", → "encoders", → "motors", → "Terminal Modules" and → "Sensor Modules," as well as complementary components such as reactors, filters, lines etc.

Droop

Droop involves making the speed controller artificially "soft" by entering an adjustable percentage of the speed controller output signal with negative sign at the speed controller input. This means that the speed is slightly reduced at higher load torques. The droop function is used to reduce the response to load surges and for certain variations of load sharing control for drives which are coupled with one another through a continuous material web. The I component or the summed output signal can be used as speed output signal. The droop can be switched-in and switched-out using a control command.

Dynamic Servo Control

Dynamic Servo Control (DSC) allows the position actual value to be evaluated in a fast speed control clock cycle directly in the drive. The position reference value (position setpoint) is entered in the position controller clock cycle from the higher-level control via the isochronous → "PROFIBUS" with → "PROFIdrive" telegrams.

Using DSC, optimum dynamic response of the position control loop can be achieved with low associated impact on the bus bandwidth. This is achieved by using sophisticated signal filtering and pre-control.

DSC allows high control gains to be achieved and therefore a high level of stiffness - for instance to quickly compensate and correct load-related track/path deviations.

Edge modulation

Type of modulation for a drive converter gating unit, where the pulses "chopped" from the DC link voltage do not appear in a fixed time grid. The edges of the output voltage which is generated are formed by several short pulses near the zero crossing - where as a wide pulse is generated at the center of every half wave. This allows a high output voltage roughly approximating to 100% of the line supply voltage and therefore ensuring good motor utilization.

Electronic rating plate

Each component of the SINAMICS drive systems which is connected via → "DRIVE-CLiQ" has an electronic rating plate.

This plate can be read out via the → "STARTER" commissioning tool and provides the following information: type, order number, version, manufacturer, serial number and rated technical data.

Encoder

An encoder is a measuring system capturing actual values for the speed and/or angular/position values and provides them for electronic processing. Depending on the mechanical construction, encoders can be incorporated in the → "motors" (→ "motor encoder") or mounted on the external mechanics (→ "external encoder"). Depending on the individual type of movement, we distinguish between rotary encoders and translatory encoders (e.g. linear encoder). In terms of measured-value provision, we distinguish between → "absolute encoders" (code sensors) and → "incremental encoders".

See → "incremental encoder TTL/HTL" → "incremental encoder sin/cos 1 Vpp" → "resolver"

EnDat protocol

Serial transmission protocol for transmitting position/angular actual values from an → "absolute encoder" to the drive or positioning control.

The EnDat protocol also allows parameterization and diagnostics of the encoder.

Fault buffer

Once a fault has occurred, the drive enters it in a fault buffer. The fault buffer can be read out via parameters.

Field weakening

The term field weakening designates the reduction of the magnetizing current of an electric motor to further increase the speed upon reaching the rated current.

Flexible response

With this function, the converter can be operated even in case of a voltage dip up to a minimum DC link voltage of approx. 50 % of the rated value (or of the parameterized line supply voltage value). In case of a voltage dip, the maximum output power of the converter decreases analogous to the current supply voltage.

In contrast to the → "kinetic buffering", a significant speed decrease can be avoided as long as the remaining power is sufficient for operating the drive with the required torque.

Flying measurement

When a hardware signal is received, the instantaneous position actual value is saved and, for example, is made available via PROFIBUS. The hardware signal can, for instance, be received from a measuring probe or a print index sensor (mechanical switch, BERO proximity switch or optical sensor). The active edge of the hardware signal can be parameterized (rising, falling, or both).

Flying restart

After Power on, the "flying restart" function automatically switches a converter to a possibly coasting motor. When switching to the rotating motor, a → "Magnetizing" must be performed first for an → "induction motor". For drives without an encoder, the current speed is → "Searched" additionally. Afterwards, the current speed setpoint in the ramp-up generator is set to the current actual speed value. The ramp-up to the definitive speed setpoint is performed from this value. The "flying restart" function may shorten the ramp-up procedure after Power on while the load is still coasting.

As a rule, the "flying restart" function may only be used for single drives as the motors of group drives (i.e. several motors connected in parallel to the converter) may have different speeds when the converter is switched off.

Application example:

After a power failure, the "flying restart" function ensures that a fan drive can be switched back to the running fan wheel as soon as possible. See → "Automatic restart".

Incremental encoder

Incremental position and speed encoder. In contrast to the → "absolute encoder", this encoder does not output an actual position value signal corresponding to the absolute path, but outputs incremental "delta position or angular signals" instead.

The following three types of incremental encoders are available → "incremental encoder TTL/HTL", → "incremental encoder sin/cos 1 Vpp" and → "resolver".

Incremental encoder TTL/HTL

Incremental position and speed measuring encoder (→ "incremental encoder"). In most cases, it outputs two pulse chains (tracks) displaced by 90 degrees with rectangular output signals and often additionally one zero pulse per revolution, respectively. The output signals feature TTL levels (in most cases +5 V RS422 differential signals; TTL = Transistor-Transistor Logic) or HTL levels (+15 or +24 V logic level; HTL = High Level Transistor Logic).

Incremental encoder sin/cos 1 Vpp

An incremental encoder sin/cos 1 Vpp is defined as a high-resolution optical sine/cosine encoder which can, for example, be incorporated in 1FK motors as a → "motor encoder".

As a rule, the following signals are output:

- Two signals displaced by 90 degrees, with respectively 2048 sinusoidal signal periods per revolution as differential signals with a 1 Vpp amplitude ("A/B sinusoidal encoder tracks").
- A reference signal (zero pulse) per revolution as a differential signal with a 0.5 Vpp amplitude.
- For some types, additionally two sinusoidal signal periods displaced by 90 degrees as differential signals with a 1 Vpp amplitude ("C/D track").

For determining the actual position or angular value, the zero crossings of the sinusoidal encoder tracks are evaluated first (rough evaluation, e.g. totally $4 \times 2048 = 8192$ zero crossings per revolution).

In addition to this, a fine evaluation can be performed by means of an analog detection of the amplitude. By combining the rough and fine evaluation, resolutions of more than 1,000,000 increments can be achieved per encoder revolution.

Examples of typical sin/cos encoders: ERN1387, ERN1381

Hub

Central connecting element in a network based on star connection technology. A hub distributes arriving data packages to all devices connected.

Kinetic buffering

The kinetic buffering (KIP) is a software function which can be used to buffer short-term power failures (up to approx. 1 s or as long as the drive is still rotating). As a rule, kinetic buffering is only used for drives which are predominantly in the motoring mode. The prerequisite is that the driven load must have a sufficiently high moment of inertia, i.e. sufficient kinetic energy. During the power failure, the KIP function initiates a motor switch-over to the no-load operation or slightly regenerative operation (in order to compensate the low losses of the motor and inverter). After the resumption of power supply, the drive system switches immediately back to normal motoring operation.

To use the kinetic buffering function, it is important that the process can tolerate that the motor coasts down or decelerates during the power failure. For some applications involving multi-motor drives (sectional drives) during the kinetic buffering phase, the speed relationships between the individual drives should be maintained so that the material web neither breaks nor is damaged. For cases such as these, it is only permissible to activate the kinetic buffering for one drive - normally the main drive. The reduced speed setpoints must be fed into the complete setpoint cascade.

Glossary

Line filter

Line filters are filters in the converter input which protect the network from harmonic loads and/or interference voltages created in the converter.

Line filters can be passive or active filters, for the lower-frequency harmonics (designated with the term line feedback) with 5, 7, 11, 13, etc. times the line frequency, and also filters for high-frequency interference voltages from 10 kHz onward (i.e. RFI suppression filters).

With SINAMICS, the term line filter only designates passive RFI suppression filters.

Line Module

A line module is a power component which creates the DC link voltage for one or several → "Motor Modules" from a three-phase mains voltage.

The following three line module types are used for SINAMICS: → "Basic Line Module", → "Smart Line Module" and → "Active Line Module".

Line reactor

Line reactors are used for reducing the line-side harmonic currents and harmonic effects.

With the → "Active Line Modules", line reactors are used as an additional energy storage.

Line-side power components

Power components arranged between the network and the converter unit, such as line reactors, network filters, line contactors, etc.

Motor

For the electric motors which can be driven by SINAMICS, a principle distinction is made between rotary and linear motors with regard to their moving direction and between synchronous and asynchronous (induction) motors with regard to their electromagnetic operating principle. For SINAMICS, the motors are connected to a → "Motor Module".

See → "synchronous motor" → "asynchronous (induction) motor" → "motor encoder"

Motor encoder

An → "encoder" integrated in the motor or built on the motor, e.g. → "resolver", → "incremental encoder TTL/HTL" or → "incremental encoder sin/cos 1 Vpp".

The encoder detects the motor speed and, in the case of synchronous motors, also the rotor position angle (of the commutation angle for the motor currents).

For drives without an additional → "direct position measuring system", it is also used as position encoder for position controlling.

Motor Module

A motor module is a power unit (DC-AC inverter) ensuring the power supply for the connected motor.

Power is supplied through the → "DC link" of the drive group.

A motor module must be connected to a → "Control Unit" via → "DRIVE-CLiQ". The open-loop and closed-loop control functions of the motor module are stored in the control unit.

There are → "Single Motor Modules" and → "Double Motor Modules".

Motor potentiometer

This function is used to simulate an electromechanical motor potentiometer for setpoint input. The setpoint is adjusted via one control command for "higher" and one for "lower".

Motor-side power components

Power components arranged between the converter unit and the motor. e.g. output filters, output reactors, etc.

Optimized pulse patterns

Complicated modulation procedure of a converter gating unit where the voltage pulses are arranged in such a way that the output current has a sinusoidal curve at an optimum approximation. This is of primary importance for achieving a high gate factor and a particularly slow torque ripple.

Output reactor

Reactor (inductivity) in the converter or inverter output for reducing the capacitive charge/discharge currents of long power cables.

Power module

A power module is an AC-AC converter, which does not have a built-in → "Control Unit".

Power supply unit

This component provides electric energy for electric and electronic components.

For SINAMICS, all components are internally connected via 24 V terminals or rails.

The power supply can be ensured by a conventional power supply unit available on the market (e.g. SITOP power) or via a → "Control Supply Module".

PROFIBUS

Field bus in accordance with the IEC 61158 standard, section 2 to 6.

PROFIdrive

This PROFIBUS profile was specified for speed- and position-controlled drives by the PROFIBUS under organization (PNO).

The PROFIdrive V3 profile is the latest version.

Resolver

Mechanically and electrically very robust and cost-efficient → "motor encoder" which does not require any incorporated electronics and which operates according to a fully electromagnetic principle: one sine and cosine signal, respectively, are induced in two coils displaced by 90 degrees. The resolver delivers all signals required for speed-controlled operation of the converter or for position control. The number of sine and cosine periods per revolution is equal to the number of pole pairs of the resolver. In the case of a double-pole resolver, the evaluation electronics may output an additional zero pulse per encoder revolution. This zero pulse ensures a unique assignment of the position information in relation to an encoder revolution. A double-pole resolver can be used as single-turn encoder.

2-pole resolvers are suitable for motors with any pole number. In the case of multi-pole resolvers, the pole pair numbers of the motor and of the resolver are always identical. For this reason, multi-pole resolvers ensure a higher resolution than 2-pole resolvers.

Safe brake relay

Certified components for the safe control of a 24 V brake coil.

See → "Brake Relay"

Safe braking control

Function associated with → "Safety Integrated".

For SINAMICS → "booksize units" the motor holding brake is controlled through two channels each with an electronic switch in the +24 V channel and in the ground channel. Both of these channels are monitored. If one of the two channels fails, then this is detected and signaled. For the booksize drive units, the braking cables are integrated in the power cable.

See → "braking control"

Safe standstill

Function of → "Safety Integrated".

In case of an error or in combination with a machine function, this function is used to safely disconnect the torque-generating energy flow to the motor. This procedure is executed drive-specific and contactless.

See → "Safety Integrated"

Safety Integrated

These safety functions are integrated into the products and ensure efficient personal and machine protection in accordance with the EC 98/37/EG machinery directive.

By means of the integrated safety functions, the requirements of safety class 3 in accordance with EN 954-1 can be met in a simple and efficient way.

Sensor Module

Hardware module for evaluating speed/position encoder signals.

Single Motor Module

A single motor module is a → "Motor Module" to which one single motor can be connected and operated.

See → "Double Motor Module"

Sine-wave filter

The sine-wave filter is connected to the converter or inverter output on the motor side. This filter has been designed for the generation of a converter output voltage with an almost sinusoidal shape.

This method protects motors whose isolation system could be damaged by voltage peaks.

In addition to this, a shielded → "Power cable" is not required in many cases. Sinusoidal filters are often required in the chemicals industry, e.g. to ensure that the permissible insulation voltage in the motor terminal box is not exceeded.

SIZER

SIZER is a tool for configuring the SINAMICS and MICROMASTER drive systems. SIZER assists with the correct technical specifications for the drive systems and selection of the drive components required for the system.

See → "STARTER"

Skip frequency band

A skip frequency band is a speed/frequency setpoint range in which the drive must not be operated. The upper and lower limits of the skip frequency band can be parameterized. If a signal value is entered from an external or internal setpoint source within the skip frequency band, this signal value is replaced by one of the skip frequency limits.

This function allows for the suppression of undesirable mechanical resonant oscillation by suppressing those speeds which could possibly excite this type of resonant oscillation.

Smart line module

Unregulated line infeed/feedback unit with a diode bridge for feeding; stall-protected, line-commutated feedback via → "IGBT"s.

The Smart Line Module provides the DC link voltage for the → "Motor Module"s. The former names "AFE-F" (AFE = Fundamental Wave) for MegaMaster and "UR unit" (unregulated feedback unit) must not be used any longer.

STARTER

A STARTER serves for the installation, start-up and parameterization of drive units. Moreover, diagnostic functions required for service tasks (e.g. PROFIBUS diagnostics, function generator, trace) can be executed.

See → "SIZER"

Synchronous motor

Synchronous motors run at the same frequency with which they are operated. They do not have a slip (like → "asynchronous (induction) motors"). Synchronous motors require different feedforward and feedback control concepts depending on their design to ensure that they can be operated with converters.

Glossary

Synchronous motors are distinguished by the following features:

- permanent-field/separately excited
- with/without damping cage
- with/without position encoder

Synchronous motors are used for different reasons:

- high drive dynamic response (→ "synchronous servo motors")
- high overload capability
- high speed accuracy with exactly specified frequency (SIEMOSYN motors)

Synchronous servo motor

Synchronous servo motors (e.g. 1FK, 1FT) are permanent-field → "synchronous motors" with position encoders such as an → "absolute encoder". As the moments of self-inertia are low, the drive is extremely dynamic. e.g. because there are no power losses due to the electric resistance of copper in the rotor, a high power density is achieved with a low construction volume.

Synchronous servo motors can only be operated in combination with converters.

Due to the servo control required for this purpose, the motor current is moment-dependent. The momentary phase relation of the motor current is derived from the (mechanical) rotor position detected by the position encoder.

Terminal Board

Terminal extension module for plugging into a → "Control Unit".

With SINAMICS, there is, for example, the Terminal Board TB30 with analog and digital I/O terminals.

Terminal Module

Terminal extension module for snapping on the installation rail, for installation in the control cabinet.

With SINAMICS, there is, for example, the Terminal Module TM31 with analog and digital I/O terminals.

Third-party motor

A motor is designated as a third-party motor if its motor data are not known to the drive group, but can be identified by means of the corresponding order number.

The motor data of an external motor are required for commissioning. They must be manually entered in the corresponding parameters.

Topology

Describes the structure of a drive system with → "Control Unit", → "Motor Modules", → "motors", → "encoders", → "Terminal Modules", including the connection system.

Travel to a fixed stop

With this function, a motor can be travelled to a fixed stop with a defined moment, without any fault message. As soon as the fixed stop is reached, the moment defined via parameters is built up and persists.

Vector control

The vector control (field-oriented control) is a high-performance control type for induction machines. It is based on an exact model calculation of the motor and of two current components which control the flow and the torque by means of software algorithms. In this way, the predefined speeds and torques can be respected and limited precisely with a good dynamic response.

There are two vector control types:

- frequency control (sensorless vector control)
- speed-torque control with speed feedback (→ "encoder")

Voltage Clamping Module

Component which limits the → "DC link" voltage and therefore also the motor voltages to permissible values in the case of resonance.

With → "Power cable"s of excessive length, excitation of the system's resonant frequency under adverse conditions can cause overvoltages to develop in the DC link. In such cases, the insulation systems of the connected motors are particularly at risk and partial discharges can occur.

This component must be used if the total length of all power cables exceeds 350 m (shielded cables) and 500 m (unshielded cables).

Voltage Sensing Module

Component which measures the actual line voltage and makes the measured data available via → "DRIVE-CLiQ". Used in conjunction with an → "Active Line Module" for feeding back the actual line voltage value.

It can be mounted on a → "Top-hat rail" and also features 2 analog inputs and a connection for a temperature sensor.

Overview

CAD CREATOR – Dimension sheet and 2D/3D CAD generator

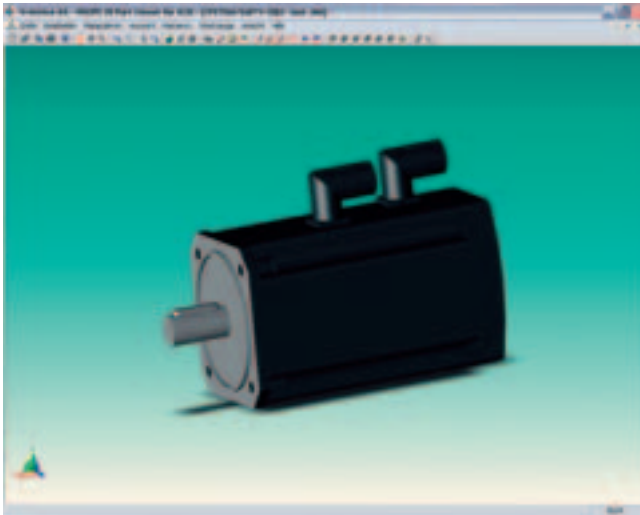

The CAD CREATOR provides a user-friendly interface which helps you to create product-specific data quickly and supports you in generating plant documentation containing project-specific information.

Benefits

- Multilingual operator interface in English, French, German, Italian and Spanish included
- Dimension sheets with measurements in mm or inches
- Dimension sheets and 2D/3D CAD data for
 - 1FT6/1FK7 synchronous motors
 - 1PH7 (up to AH 160)/IPH4 asynchronous motors
 - 1FT6/1FK7/1FK7-DYA geared motors
 - 1FW3 torque motors

The CAD CREATOR provides you with various options to begin the product configuration:

- Order number
- Order number search
- Geometric data

Once a product is successfully configured, the product-specific information, such as dimension drawing and 2D/3D CAD data are displayed and made available for storing in various formats, e.g.: *.pdf, *.dxf, *.stp or *.igs.

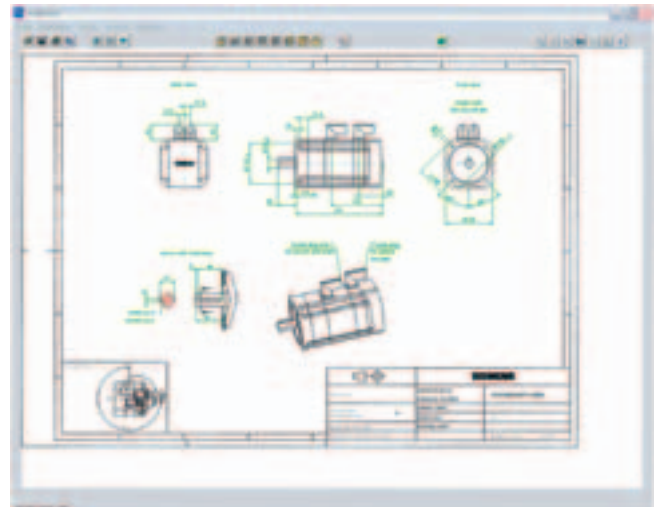

The CAD CREATOR is available on CD-ROM and as an Internet application.

Additional information is available in the Internet under:

<http://www.siemens.de/cad-creator>

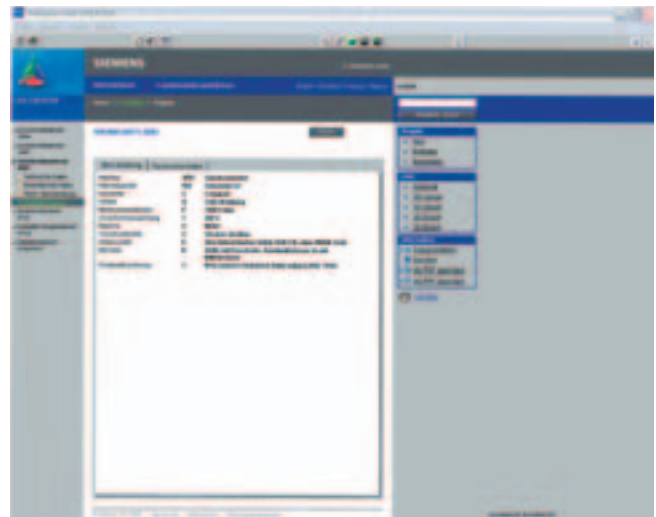

Further information

Appendix

Siemens Contacts Worldwide



At

<http://www.siemens.com/automation/partner>

you can find details of Siemens contact partners worldwide responsible for particular technologies.

In most cases you can obtain a contact partner for

- Technical Support,
- Spare parts/repairs,
- Service,
- Training,
- Sales or
- Consultation/engineering.

You start by selecting a

- Country,
- Product or
- Sector.

By further specifying the remaining criteria you will find exactly the right contact partner with his/her respective expertise.

A&D in the WWW



A detailed knowledge of the range of products and services available is essential when planning and configuring automation systems. It goes without saying that this information must always be fully up-to-date.

The Siemens Automation and Drives Group (A&D) has therefore built up a comprehensive range of information in the World Wide Web, which offers quick and easy access to all data required.

Under the address

<http://www.siemens.com/automation>

you will find everything you need to know about products, systems and services.

Product Selection Using the Offline Mall of Automation and Drives

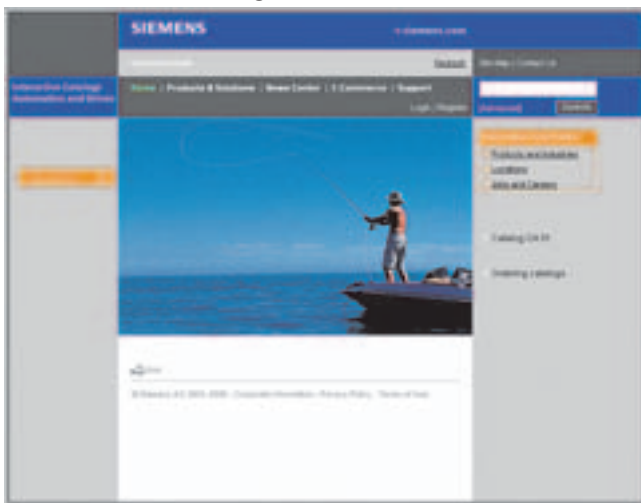

Detailed information together with convenient interactive functions:

The Offline Mall CA 01 covers more than 80.000 products and thus provides a full summary of the Siemens Automation and Drives product base.

Here you will find everything that you need to solve tasks in the fields of automation, switchgear, installation and drives.

All information is linked into a user interface which is easy to work with and intuitive.

After selecting the product of your choice you can order at the press of a button, by fax or by online link.

Information on the Offline Mall CA 01 can be found in the Internet under

<http://www.siemens.com/automation/ca01>

or on CD-ROM or DVD.

Easy Shopping with the A&D Mall



The A&D Mall is the virtual department store of Siemens AG in the Internet. Here you have access to a huge range of products presented in electronic catalogs in an informative and attractive way.

Data transfer via EDIFACT allows the whole procedure from selection through to ordering and right through to tracking of the order to be carried out online via the Internet.

Numerous functions are available to support you.

For example, powerful search functions make it easy to find the required products, which can be immediately checked for availability. Customer-specific discounts and preparation of quotes can be carried out online, as well as order tracking and tracing.

Please visit the A&D Mall on the Internet under:

<http://www.siemens.com/automation/mall>

Subject Index

	Chapter/Page		Chapter/Page
A		F	
Absolute encoder	4/3	Filters	2/50, 2/58, 2/67, 2/77
AC motors	3		
Active Interface Modules	2/98	G	
Active Line Modules, booksize format	2/79	Gearboxes	3/46
Active Line Modules, chassis format	2/91	Geared servo motors	3/62
Applications	7/2	General technical data	2/6
Asynchronous motors	3/111		
		H	
B		Heat dissipation	6/36
Basic Line Filters	2/88		
Basic Line Modules, chassis format	2/60	I	
BOP20 Basic Operator Panel	2/159	Incremental encoders	4/3
Brake Relay	2/176		
Braking Modules, booksize format	2/133	L	
Braking Modules, chassis format	2/135	Length codes for cables	5/20
Braking resistors for booksize format	2/138	Line filters	2/50, 2/58, 2/67, 2/77
Braking resistors for chassis format	2/140	Line Modules	2/60 - 2/104
Braking resistors for chassis format	2/141	Line reactors	2/47, 2/57, 2/66, 2/76, 2/85
Built-on optoelectronic rotary encoders	4/2	Line-side components	2/51, 2/59, 2/68, 2/78, 2/89, 2/104
		Load-side power components	2/148
C			
Capacitor Modules, booksize format	2/143	M	
CBC10 Communication Board	2/160	Mechanical installation of the drive system	6/34
CBE20 Communication Board	2/161	Measuring system SIMODRIVE sensor	4
CBE30 Communication Board	2/162	MOTION-CONNECT	5
Communication	2/7	MOTION-CONNECT connection system	5
CompactFlash Card for CU310/CU320	2/26	Motor Modules	2/105 - 2/132
Compact geared motors	3/58	Motor selection	6/15
Configuration sequence	6/3	Motor reactors	2/148 - 2/156
Control Units	2/14	Motors	3
Control Supply Module, booksize format	2/144	Motors selection guides	3/108
CUA31 Control Unit Adapter	2/163	Mounting accessories for built-on rotary encoders	4/8
CU310 DP Control Unit	2/17		
CU310 PN Control Unit	2/20	O	
CU320 Control Unit	2/23	Opto-electronic rotary encoders	4/2
		Overload capability	6/20
D		Overview of motors	3/2 - 3/5
Data overview of motors	3/2 - 3/5		
DC link components	2/133 - 2/147	P	
DC link supply adapter for booksize format	2/146	Parallel connection of power units	6/24
Degree of protection for motors	3/6, 3/109	Power cables	5/5
Derating characteristic curves	6/20	Power Modules blocksize format	2/35
Dimension drawings of motors	3/176	Power Modules chassis format	2/52
DMC20 DRIVE-CLiQ Hub Module	2/165	PROFIBUS	2/10
Documentation	7/12	PROFIdrive	2/8
Double Motor Modules, booksize format	2/126	PROFINET	2/11
DRIVE-CLiQ	5		
Drive Converter System	1/10	R	
Drive ES	2/33	Reactors	2/47, 2/57, 2/66, 2/76, 2/85
Drive ES Engineering System	2/33		
E			
Encoder system connection	2/178		
Encoder systems principle of operation	3/12		
Engineering Software	2/32		
Explosion-protected motors	3/96		

Subject Index

	Chapter/Page		Chapter/Page
S		T	
Safe Brake Relay	2/176	TB30 Terminal Board	2/166
Safety functions	6/14	TM15 Terminal Module	2/168
Safety Integrated	6/14	TM31 Terminal Module	2/170
Service & Support	7/11	TM41 Terminal Module	2/172
Signal cables	5/11	Torque motors	3/100
SIMAG H2 hollow-shaft measuring system	4/9	Totally Integrated Automation	1/4
SIMODRIVE sensor	4	Training	7/3
SIMOTION SCOUT	2/34	Training case	7/5 -7/10
SIMOTION CX32 Controller Extension	2/31	Types of construction of motors	3/109
SIMOTION D Control Units	2/28		
SIMOTION SCOUT Engineering Software	2/34	V	
SINAMICS S120 introduction	1/9	Varnished modules	2/5
Single Motor Modules booksize format	2/105	Ventilation clearances	6/36
Single Motor Modules chassis format	2/114	Voltage Clamping Module booksize format	2/147
Sinusoidal filter for chassis format	2/157	VSM10 Voltage Sensing Module	2/174
SIZER	6/2		
SIZER configuration tool	6/2	W	
Smart Line Modules, booksize format	2/69	Wideband Line Filter	2/86
SMC Sensor Module Cabinet-Mounted	2/179 - 2/181		
SMe20/SME25 Sensor Modules External	2/182		
Software	2/32		
STARTER	2/32		
STARTER drive/commissioning software	2/32		
Supply adapter for booksize format	2/146		
Synchronous motors	3/14		
System description (configuration)	6		
System disturbance	6/26		
System overview	2/		

Further information

Appendix

Order Number Index

Order Number Index

		Chapter/Page			Chapter/Page
1FK7...	Synchronous motors	3/38 - 3/45	6AG1064-1AA0.-0AA0	Control box/line adapter	7/7
	Planetary gearboxes	3/51 - 3/57	6AU14.5-0AA00-0AA.	SIMOTION D Control Unit	2/30
	DYA compact geared motors	3/58 - 3/61	6AU1400-2NA00-0AA0	CompactFlash card	2/30
	Geared servo motors	3/62 - 3/95	6ES7972-0B...	PROFIBUS connector	2/17, 2/25
1FS6...	Explosion-protected motors	3/96 - 3/99	6FC5247-0AA18-0AA0	Battery	2/30
1FT6...	Synchronous motors	3/14 - 3/37	6FC5312-0FA00-0AA0	CBE30 Communication Board	2/162
	Planetary gearboxes	3/46 - 3/50	6FC5348-0AA01-0AA0	Battery and fan module	2/30
1FW3...	Torque motors	3/100 - 3/107	6FC9341-2A.	SUB-D connector, 9-pin	2/160
1PH4...	Asynchronous motors	3/167 - 3/175	6FX2001-2...	Incremental encoder with TTL (RS422)	4/5
1PH7...	Asynchronous motors	3/112 - 3/139, 3/158 - 3/166	6FX2001-3...	Incremental encoder with sin/cos 1Vpp	4/5
1PL6...	Asynchronous motors	3/140 - 3/166	6FX2001-4...	Incremental encoder with HTL	4/5
3KA5...	Main switch (switch disconnecter)	2/51, 2/59, 2/89	6FX2001-5...	Absolute encoder	4/7
3KL...	Switch disconnecter with fuse holders	2/51, 2/59, 2/68, 2/78, 2/89, 2/104	6FX2001-6...	SIMAG H2 Hollow-shaft measuring system	4/10
3KX3552-3EA01	Leading auxiliary switch for main switch/switch disconnecter	2/89	6FX2001-7KF..	Spring disk coupling	4/8
3LD2...	Main switch (switch disconnecter)	2/51, 2/78, 2/89	6FX2001-7KP01	Clamp strap	4/8
3LD9200-5B	Leading auxiliary switch for main switch	2/89	6FX2001-7KS..	Plug-in coupling	4/8
3NA3...	Cable protection fuse	2/51, 2/59, 2/68, 2/78, 2/90, 2/104	6FX2002-1DC...	DRIVE-CLiQ cables	5/17
3NC1091	Cylindrical fuse switch disconnecter	2/51	6FX2003-0S...	Replacement connector/mating connector	4/8
3NE1...	Cable protection fuse incl. semiconductor protection	2/68, 2/104, 6/36	6FX2003-1SA00	Power connector	5/10
3NP...	Fuse	2/51, 2/59, 2/78, 2/89	6FX2003-7...	Flange and FH clamp	5/10, 5/19
3NW600...	Fuse switch disconnecter	2/51	6FX2003-8PS..	Pin contact	5/10
3RT1...	Main connector	2/51, 2/59, 2/68, 2/78, 2/89	6FX5...	MOTION-CONNECT 500	5/6 to 5/9, 5/17
3RT1476-6AP36	Bypass contactor	2/104	6FX8...	MOTION-CONNECT 800	5/6 to 5/9, 5/17
3RV10...	Circuit-breaker	2/51, 2/78, 2/89	6GK1901-1BB10-2A..	Industrial Ethernet FC RJ45 Plug 180	2/20
3TX7004-1LB00	Output interface for main contactor (relay coupler)	2/89	6GK1901-1BB30-0A..	Industrial Ethernet FC RJ45 Plug 145	2/161, 2/162
3VL...	Circuit-breaker	2/51, 2/59	6GK1901-1GA00	Industrial Ethernet FC Stripping Tool	2/20, 2/161, 2/162
3WL1...-Z C22	Fixed-mounted circuit-breaker	2/68	6SE6400-2FA00-6AD0	Line filter for PM340 Power Module blocksize format	2/50
3WL111...	Bypass contactor/ fixed-mounted circuit breaker	2/104	6SE6400-3CC...	Line reactor for PM340 Power Module blocksize format	2/49
3WL121...	Bypass contactor/ fixed-mounted circuit breaker	2/104	6SE6400-3TC...	Motor reactor for blocksize format	2/150
5SB411	DIAZED fuse	2/90	6SE6400-4B...	Braking module for blocksize format	2/135
5SC211	DIAZED fuse	2/90	6SE70...	Motor reactor for booksize format	2/151
5SE2335	NEOZED fuse	2/90			
5SY611...	Miniature circuit breaker	2/51			
5TT57...	Main contactor (insta contactor)	2/51			

Order Number Index

		Chapter/Page			Chapter/Page
6SL3000-0B...	Line filter for Basic Line Module chassis format	2/67	6SL3055-0AA00-4BA0	BOP20 Basic Operator Panel	2/159
6SL3000-0BE21-6DA0	Line filter for Smart Line Module booksize format	2/77	6SL3055-0AA00-5.A0	SME20/SME25 Sensor Module External	2/182
	Basic Line Filter for Active Line Module booksize format	2/88	6SL3055-0AA00-5AA0	SMC10 Sensor Module Cabinet-Mounted	2/179
6SL3000-0BE23-6DA0	Line filter for Smart Line Module booksize format	2/77	6SL3055-0AA00-5BA1	SMC20 Sensor Module Cabinet-Mounted	2/180
	Basic Line Filter for Active Line Module booksize format	2/88	6SL3055-0AA00-5CA1	SMC30 Sensor Module Cabinet-Mounted	2/181
6SL3000-0BE25-5DA0	Basic Line Filter for Active Line Module booksize format	2/88	6SL3055-0AA00-6AA0	DMC20 DRIVE-CLiQ Hub Module	2/165
6SL3000-0BE3...	Line filter for Power Module chassis format	2/58	6SL3060-1FE21-6AA0	Adapter set for line filter package	2/87
6SL3000-0C...	Line reactor for Basic Line Module chassis format	2/66	6SL3060-4A...	DRIVE-CLiQ cable	5/17
6SL3000-0CE...	Line reactor for Smart Line Module booksize format	2/76	6SL3064-1BB00-0AA0	Spacers	2/25, 2/30
6SL3000-0CE3...	Line reactor for Power Modules chassis format	2/57	6SL3066-2DA00-0A.0	DRIVE-CLiQ cabinet conduit and coupling	5/19
6SL3000-0DE31-2BA0	Line reactor for Active Line Module booksize format	2/85	6SL3070-0AA00-0AG0	SINAMICS MICROMASTER SIZER configuration tool	6/2
6SL3000-0FE...	Line filter package for Active Line Module booksize format	2/86	6SL3072-0AA00-0AG0	STARTER commissioning tool	2/17, 2/20, 2/25, 2/32
6SL3000-0HE...	Line filter for Smart Line Module booksize format	2/77	6SL3074-0AA01-0AA0	Firmware license	2/26
6SL3000-1B...	Braking resistor for chassis format	2/142	6SL3097-2A...	SINAMICS S120 documentation	7/12
6SL3000-2A...	Motor reactor for chassis format	2/156	6SL3100-1AE31-0AB0	Braking Module booksize format	2/133
6SL3000-2BE3...	Motor reactor for chassis format	2/156	6SL3100-1BE31-0AA0	Braking resistor for booksize format	2/140
6SL3000-2CE3...	Sinusoidal filter for chassis format	2/158	6SL3100-1CE14-0AA0	Capacitor Module booksize format	2/143
6SL3040-0LA00-0AA0	Sinusoidal filter for chassis format	2/17	6SL3100-1DE22-0AA0	Control Supply Module booksize format	2/144
6SL3040-0LA01-0AA0	CU310 DP Control Unit	2/20	6SL3100-1VE00-0AA0	Voltage Clamping Module booksize format	2/147
6SL3040-0MA00-0AA1	CU320 Control Unit	2/25	6SL3120-1TE...	Single Motor Module booksize format, internal air cooling	2/111
6SL3040-0NA00-0AA0	SIMOTION CX32 Controller Extension	2/31	6SL3120-2TE...	Double Motor Module booksize format, internal air cooling	2/130
6SL3040-0PA00-0AA0	CUA31 Control Unit Adapter	2/163	6SL3121-1TE...	Single Motor Module booksize format, external air cooling	2/111
6SL3053-0AA00-3AA0	VSM10 Voltage Sensing Module	2/174	6SL3121-2TE...	Double Motor Module booksize format, external air cooling	2/130
6SL3054-0AA0...	CompactFlash Card for CU310 DP, CU310 PN and CU320 Control Units	2/26	6SL3130-6...	Smart Line Module booksize format, internal air cooling	2/74
6SL3055-0AA00-2CA0	CBC10 Communication Board	2/160	6SL3130-7TE...	Active Line Module booksize format, internal air cooling	2/83
6SL3055-0AA00-2EB0	CBE20 Communication Board	2/161	6SL3131-6AE...	Smart Line Module booksize format, external air cooling	2/74
6SL3055-0AA00-2TA0	TB30 Terminal Board	2/166	6SL3131-7TE...	Active Line Module booksize format, external air cooling	2/83
6SL3055-0AA00-3AA0	TM31 Terminal Module	2/170			
6SL3055-0AA00-3FA0	TM15 Terminal Module	2/168			
6SL3055-0AA00-3PA0	TM41 Terminal Module	2/172			

Further information

Appendix

Order Number Index

Order Number Index

		Chapter/Page			Chapter/Page
6SL3162-1A...	Shield connection kit	2/74, 2/83, 2/111	6SN1113-1AA00-0DA0	Braking resistor for booksized format	2/140
6SL3162-2AA0-0AA0	24 V terminal adapter/24 V jumper	2/74, 2/83, 2/111, 2/130	6SN1162-0GA00-0CA0	Adapter set for line filter package	2/87
6SL3162-2B...	DC link adapter	2/74, 2/83, 2/111, 2/130, 2/146, 6/36	6SN1197-0A...	Motor documentation	7/12
6SL3162-2MA00-0AA0	Power connector	2/111, 2/130, 5/10	6SN1197-0AB10-0YP4	User manual	4/7
6SL3166-3AB00-0AA0	Warning signs in foreign languages	2/74, 2/83, 2/111, 2/130, 2/133, 2/143, 2/144, 2/147	6SW1700-...	Drive ES	2/33
6SL3201-0BE12-0AA0	Braking resistor for blocksize format	2/135	6SX7002-0A...	Pre-assembled cables for encoder	5/18
6SL3202-0A...	Motor reactor for blocksize format	2/150	6XV1840-2AH10	FC Industrial Ethernet GP Standard Cable 2x2	2/20, 2/161, 2/162
6SL3203-0C...	Line reactor for Power Module PM340 blocksize format	2/49	6XV1840-3AH10	FC Industrial Ethernet Trailing Cable 2x2	2/20, 2/161, 2/162
6SL3210-1S...	Power Module PM340 blocksize format	2/44	6XV1840-4AH10	FC Industrial Ethernet Marine Cable 2x2	2/20, 2/161, 2/162
6SL3252-0BB0-0AA0	Brake Relay/Safe Brake Relay	2/176	6XV1870-2B	FC Industrial Ethernet GP Flexible Cable 2x2	2/20, 2/161, 2/162
6SL3262-1A...	Shield connection kit for PM340	2/44	6XV1870-2D	FC Industrial Ethernet GP Trailing Cable 2x2	2/20, 2/161, 2/162
6SL3300-1A...	Braking Module chassis format	2/135	6ZB2470-0AE00	SIMOTION D435 training case	7/9
6SL3300-7T...	Active Interface Module	2/98	6ZB2470-0AG00	SIMOTIOND435 upgrade kit	7/8
6SL3310-1TE3...	Power Module chassis format	2/52	6ZB2470-0AH00	SIMOTIOND435 upgrade kit	7/8
6SL3320-1T...	Single Motor Module chassis format	2/114	6ZB2480-0...	SINAMICSS120 training case	7/7
6SL3330-1T...	Basic Line Module chassis format	2/60	6ZB2480-0CB00	ASM training case	7/10
6SL3330-7T...	Active Line Module chassis format	2/91	E86060-D6850-A100-C4-7400	SITRAINonCD interactive course information system on CD-ROM	7/3
6SL3366-2NG00-0AA0	Cable harness set	2/135	E86060-K6850-A101-B6	Catalog ITC	7/3
6SN1111-0AA00-...	Line reactor for Active Line Module booksized format	2/85	E86060-P6850-A101-D2	Dates and price list for catalog ITC	7/3
			ISBN3-89578-074-X	Decentralization with PROFIBUS DP	4/7

To**Your address**

**Siemens AG, A&D MC MS 1
D 21.1-2006
Postfach 31 80
91050 ERLANGEN,
GERMANY**

Name

Function

Company/Department

Fax: +49/9131-98-1145

E-mail:

motioncontrol.docu@
siemens.com

No./Street

ZIP/Town

Tel./Fax No.

Your opinion is important to us!

Our catalog should be an important and convenient reference for you. For this reason, we are constantly striving to improve the catalog.

That's why we would ask you to complete this questionnaire and fax it back to us.
Thank you!

For the following points, please enter your personal assessment with values from 1 (= good) to 6 (= bad):

Do the contents meet your requirements?

Do the technical details satisfy your requirements?

Is it easy to find the information you need?

How do you assess the quality of the graphics and diagrams?

Is the text easy to understand?

Do you have any suggestions for improvement? Have you found any printing errors?

Further information

Appendix

Conversion Tables

Rotary inertia (to convert from A to B, multiply by entry in table)

A \ B	lb-in ²	lb-ft ²	lb-in-s ²	lb-ft-s ² slug-ft ²	kg-cm ²	kg-cm-s ²	gm-cm ²	gm-cm-s ²	oz-in ²	oz-in-s ²
lb-in ²	1	6.94×10^{-3}	2.59×10^{-3}	2.15×10^{-4}	2.926	2.98×10^{-3}	2.92×10^3	2.984	16	4.14×10^{-2}
lb-ft ²	144	1	0.3729	3.10×10^{-2}	421.40	0.4297	4.21×10^5	429.71	2304	5.967
lb-in-s ²	386.08	2.681	1	8.33×10^{-2}	1.129×10^3	1.152	1.129×10^6	1.152×10^3	6.177×10^3	16
lb-ft-s ² slug-ft ²	4.63×10^3	32.17	12	1	1.35×10^4	13.825	1.355×10^7	1.38×10^4	7.41×10^4	192
kg-cm ²	0.3417	2.37×10^{-3}	8.85×10^{-4}	7.37×10^{-5}	1	1.019×10^{-3}	1000	1.019	5.46	1.41×10^{-2}
kg-cm-s ²	335.1	2.327	0.8679	7.23×10^{-2}	980.66	1	9.8×10^5	1000	5.36×10^3	13.887
gm-cm ²	3.417×10^{-4}	2.37×10^{-6}	8.85×10^{-7}	7.37×10^{-8}	1×10^{-3}	1.01×10^{-6}	1	1.01×10^{-3}	5.46×10^{-3}	1.41×10^{-5}
gm-cm-s ²	0.335	2.32×10^{-3}	8.67×10^{-4}	7.23×10^{-5}	0.9806	1×10^{-3}	980.6	1	5.36	1.38×10^{-2}
oz-in ²	0.0625	4.34×10^{-4}	1.61×10^{-4}	1.34×10^{-5}	0.182	1.86×10^{-4}	182.9	0.186	1	2.59×10^{-3}
oz-in-s ²	24.13	0.1675	6.25×10^{-2}	5.20×10^{-3}	70.615	7.20×10^{-2}	7.09×10^4	72.0	386.08	1

Torque (to convert from A to B, multiply by entry in table)

A \ B	lb-in	lb-ft	oz-in	N-m	kg-cm	kg-m	gm-cm	dyne-cm
lb-in	1	8.333×10^{-2}	16	0.113	1.152	1.152×10^{-2}	1.152×10^3	1.129×10^6
lb-ft	12	1	192	1.355	13.825	0.138	1.382×10^4	1.355×10^7
oz-in	6.25×10^{-2}	5.208×10^{-3}	1	7.061×10^{-3}	7.200×10^{-2}	7.200×10^{-4}	72.007	7.061×10^4
N-m	8.850	0.737	141.612	1	10.197	0.102	1.019×10^4	1×10^7
kg-cm	0.8679	7.233×10^{-2}	13.877	9.806×10^{-2}	1	10^{-2}	1000	9.806×10^5
kg-m	86.796	7.233	1.388×10^3	9.806	100	1	1×10^5	9.806×10^7
gm-cm	8.679×10^{-4}	7.233×10^{-5}	1.388×10^{-2}	9.806×10^{-5}	1×10^{-3}	1×10^{-5}	1	980.665
dyne-cm	8.850×10^{-7}	7.375×10^{-8}	1.416×10^{-5}	10^{-7}	1.0197×10^{-6}	1.019×10^{-8}	1.019×10^{-3}	1

Length (to convert from A to B, multiply by entry in table)

A \ B	inches	feet	cm	yd	mm	m
inches	1	0.0833	2.54	0.028	25.4	0.0254
feet	12	1	30.48	0.333	304.8	0.3048
cm	0.3937	0.03281	1	1.09×10^{-2}	10	0.01
yd	36	3	91.44	1	914.4	0.914
mm	0.03937	0.00328	0.1	1.09×10^{-3}	1	0.001
m	39.37	3.281	100	1.09	1000	1

Force (to convert from A to B, multiply by entry in table)

A \ B	lb	oz	gm	dyne	N
lb	1	16	453.6	4.448×10^5	4.4482
oz	0.0625	1	28.35	2.780×10^4	0.27801
gm	2.205×10^{-3}	0.03527	1	1.02×10^{-3}	N.A.
dyne	2.248×10^{-6}	3.59×10^{-5}	980.7	1	0.00001
N	0.22481	3.5967	N.A.	100000	1

Power (to convert from A to B, multiply by entry in table)

A \ B	HP	Watts
HP (English)	1	745.7
(lb-in) (deg./sec)	2.645×10^{-6}	1.972×10^{-3}
(lb-in) (rpm)	1.587×10^{-5}	1.183×10^{-2}
(lb-ft) (deg./sec)	3.173×10^{-5}	2.366×10^{-2}
(lb-ft) (rpm)	1.904×10^{-4}	0.1420
Watts	1.341×10^{-3}	1

Mass (to convert from A to B, multiply by entry in table)

A \ B	lb	oz	gm	kg	slug
lb	1	16	453.6	0.4536	0.0311
oz	6.25×10^{-2}	1	28.35	0.02835	1.93×10^{-3}
gm	2.205×10^{-3}	3.527×10^{-2}	1	10^{-3}	6.852×10^{-5}
kg	2.205	35.27	10^3	1	6.852×10^{-2}
slug	32.17	514.8	1.459×10^4	14.59	1

Rotation (to convert from A to B, multiply by entry in table)

A \ B	rpm	rad/sec.	degrees/sec.
rpm	1	0.105	6.0
rad/sec.	9.55	1	57.30
degrees/sec.	0.167	1.745×10^{-2}	1

Temperature Conversion

°F	°C	°C	°F
0	-17.8	-10	14
32	0	0	32
50	10	10	50
70	21.1	20	68
90	32.2	30	86
98.4	37	37	98.4
212	100	100	212
subtract 32 and multiply by $\frac{5}{9}$		multiply by $\frac{9}{5}$ and add 32	

Mechanism Efficiencies

Acme-screw with brass nut	~0.35–0.65
Acme-screw with plastic nut	~0.50–0.85
Ball-screw	~0.85–0.95
Chain and sprocket	~0.95–0.98
Preloaded ball-screw	~0.75–0.85
Spur or bevel-gears	~0.90
Timing belts	~0.96–0.98
Worm gears	~0.45–0.85
Helical gear (1 reduction)	~0.92

Friction Coefficients

Materials	μ
Steel on steel (greased)	~0.15
Plastic on steel	~0.15–0.25
Copper on steel	~0.30
Brass on steel	~0.35
Aluminum on steel	~0.45
Steel on steel	~0.58
Mechanism	μ
Ball bushings	<0.001
Linear bearings	<0.001
Dove-tail slides	~0.2++
Gibb ways	~0.5++

Material Densities

Material	lb-in ³	gm-cm ³
Aluminum	0.096	2.66
Brass	0.299	8.30
Bronze	0.295	8.17
Copper	0.322	8.91
Hard wood	0.029	0.80
Soft wood	0.018	0.48
Plastic	0.040	1.11
Glass	0.079–0.090	2.2–2.5
Titanium	0.163	4.51
Paper	0.025–0.043	0.7–1.2
Polyvinyl chloride	0.047–0.050	1.3–1.4
Rubber	0.033–0.036	0.92–0.99
Silicone rubber, without filler	0.043	1.2
Cast iron, gray	0.274	7.6
Steel	0.280	7.75

Wire Gauges ¹⁾

Cross-section mm ²	Standard Wire Gauge (SWG)	American Wire Gauge (AWG)
0.2	25	24
0.3	23	22
0.5	21	20
0.75	20	19
1.0	19	18
1.5	17	16
2.5	15	13
4	13	11
6	12	9
10	9	7
16	7	6
25	5	3
35	3	2
50	0	1/0
70	000	2/0
95	00000	3/0
120	0000000	4/0
150	–	6/0
185	–	7/0

¹⁾ The table shows approximate SWG/AWG sizes nearest to standard metric sizes; the cross-sections do not match exactly.

Conditions of sale and delivery

Terms and Conditions of Sale and Delivery

By using this catalog you can acquire hardware and software products described therein from Siemens AG subject to the following terms. Please note! The scope, the quality and the conditions for supplies and services, including software products, by any Siemens entity having a registered office outside of Germany, shall be subject exclusively to the General Terms and Conditions of the respective Siemens entity. The following terms apply exclusively for orders placed with Siemens AG.

For customers with a seat or registered office in Germany

The "General Terms of Payment" as well as the "General Conditions for the Supply of Products and Services of the Electrical and Electronics Industry" shall apply.

For software products, the "General License Conditions for Software Products for Automation and Drives for Customers with a Seat or registered Office in Germany" shall apply.

For customers with a seat or registered office outside of Germany

The "General Terms of Payment" as well as the "General Conditions for Supplies of Siemens. Automation and Drives for Customers with a Seat or registered Office outside of Germany" shall apply.

For software products, the "General License Conditions for Software Products for Automation and Drives for Customers with a Seat or registered Office outside of Germany" shall apply.

General

The dimensions are in mm. In Germany, according to the German law on units in measuring technology, data in inches only apply to devices for export.

Illustrations are not binding.

Insofar as there are no remarks on the corresponding pages, - especially with regard to data, dimensions and weights given - these are subject to change without prior notice.

The prices are in € (Euro) ex works, exclusive packaging.

The sales tax (value added tax) is not included in the prices. It shall be debited separately at the respective rate according to the applicable legal regulations.

Prices are subject to change without prior notice. We will debit the prices valid at the time of delivery.

Surcharges will be added to the prices of products that contain silver, copper, aluminum, lead and/or gold, if the respective basic official prices for these metals are exceeded. These surcharges will be determined based on the official price and the metal factor of the respective product.

The surcharge will be calculated on the basis of the official price on the day prior to receipt of the order or prior to the release order.

The metal factor determines the official price as of which the metal surcharges are charged and the calculation method used. The metal factor, provided it is relevant, is included with the price information of the respective products. An exact explanation of the metal factor can be found on the page entitled "Metal surcharges".

The texts of the Comprehensive Terms and Conditions of Sale and Delivery are available free of charge from your local Siemens business office under the following Order Nos.:

- 6ZB5310-0KR30-0BA1
(for customers based in Germany)
- 6ZB5310-0KS53-0BA1
(for customers based outside of Germany)

or download them from the Internet
<http://www.siemens.com/automation/mall>
(Germany: A&D Mall Online-Help System)

Export regulations

The products listed in this catalog / price list may be subject to European / German and/or US export regulations.

Therefore, any export requiring a license is subject to approval by the competent authorities.

According to current provisions, the following export regulations must be observed with respect to the products featured in this catalog / price list:

AL	Number of the <u>German Export List</u> Products marked other than "N" require an export license. In the case of software products, the export designations of the relevant data medium must also be generally adhered to. Goods labeled with an <u>"AL" not equal to "N"</u> are subject to a European or German export authorization when being exported out of the EU.
ECCN	<u>Export Control Classification Number</u> . Products marked other than "N" are subject to a reexport license to specific countries. In the case of software products, the export designations of the relevant data medium must also be generally adhered to. Goods labeled with an <u>"ECCN" not equal to "N"</u> are subject to a US re-export authorization.

Even without a label or with an "AL: N" or "ECCN: N", authorization may be required due to the final destination and purpose for which the goods are to be used.

The deciding factors are the AL or ECCN export authorization indicated on order confirmations, delivery notes and invoices.

Errors excepted and subject to change without prior notice.

A&D/VuL_mit MZ/En 05.09.06

Explanation of the metal factor

Surcharges will be added to the prices of products that contain silver, copper, aluminum, lead and/or gold if the respective basic official prices for these metals are exceeded.

The surcharges will be determined based on the following criteria:

- Official price of the metal
Official price on the day prior to receipt of the order or prior to the release order (= daily price) for
 - silver (sale price of the processed material),
 - gold (sale price of the processed material)
 Source: Umicore, Hanau
(<http://www.metalsmanagement.umicore.com>)
and for
 - copper (low DEL notation + 1%),
 - aluminum (aluminum in cables) and
 - lead (lead in cables)
 Source: German Trade Association for Cables and Conductors
(<http://www.kabelverband.de>)
- Metal factor of the products
Certain products are assigned a metal factor. The metal factor determines the official price as of which the metal surcharges are charged and the calculation method used (weight or percentage method). An exact explanation is given below.

Structure of the metal factor

The metal factor consists of several digits; the first digit indicates whether the method of calculation refers to the list price or a discounted price (customer net price) (L = list price / N = customer net price).

The remaining digits indicate the method of calculation used for the respective metal. If no surcharge is added, a "-" is used.

1st digit	List or customer net price using the percentage method
2nd digit	for silver (AG)
3rd digit	for copper (CU)
4th digit	for aluminum (AL)
5th digit	for lead (PB)
6th digit	for gold (AU)

Weight method

The weight method uses the basic official price, the daily price and the raw material weight. In order to calculate the surcharge, the basic official price must be subtracted from the daily price. The result is then multiplied by the raw material weight.

The basic official price can be found in the table below using the number (2 to 9) of the respective digit of the metal factor. The raw material weight can be found in the respective product descriptions.

Percentage method

Use of the percentage method is indicated by the letters A-Z at the respective digit of the metal factor.

The surcharge is increased - dependent on the deviation of the daily price compared with the basic official price - using the percentage method in "steps" and consequently offers surcharges that remain constant within the framework of this "step range". A higher percentage rate is charged for each new step. The respective percentage level can be found in the table below.

Metal factor examples

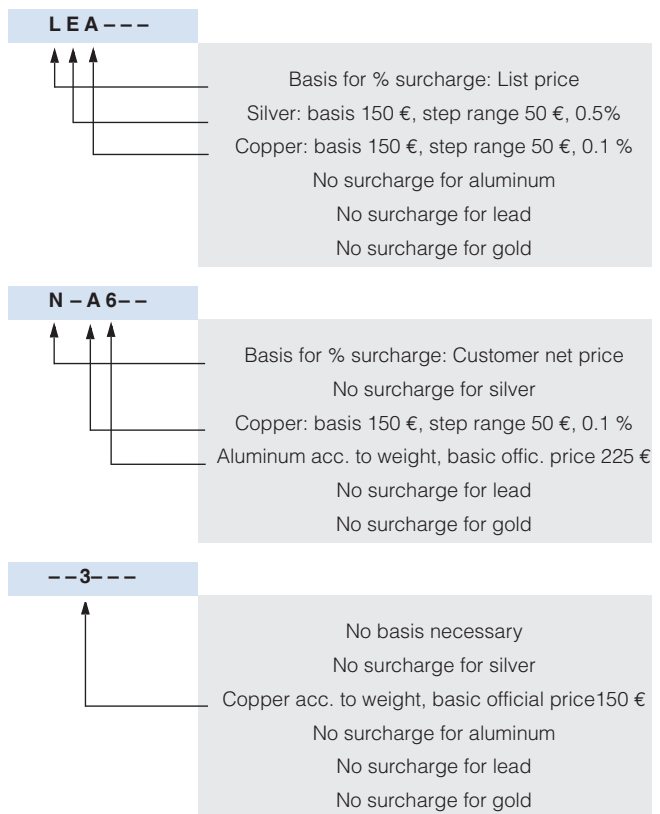

A&D/MZ_1/En 05.09.06

Further information

Appendix



Siemens AG
Automation and Drives
[Motion Control System](#)
Postfach 31 80
91050 ERLANGEN
GERMANY

Order No.
E86060-K5521-A111-A2-7600
KG 1106 12.0 BD 536 EN/ 722152
Printed in Germany

Further information can be obtained from our branch offices listed in the appendix or at www.siemens.com/automation/partner

Automation and Drives		<i>Catalog</i>
Interactive catalog on CD-ROM and on DVD		
• The Offline Mall of Automation and Drives	CA 01	
Automation Systems for Machine Tools		
SINUMERIK & SIMODRIVE	NC 60	
SINUMERIK & SINAMICS	NC 61	
Drive Systems		
<u>Variable-Speed Drives</u>		
SINAMICS G130 Drive Converter Chassis Units, SINAMICS G150 Drive Converter Cabinet Units	D 11	
SINAMICS G110 Inverter Chassis Units	D 11.1	
SINAMICS GM150/SINAMICS SM150 Medium-Voltage Converters	D 12	
SINAMICS S120 Drive System	D 21.1	
SINAMICS S150 Drive Converter Cabinet Units	D 21.3	
Asynchronous Motors Standardline	D 86.1	
Synchronous Motors with Permanent-Magnet Technology, HT-direct	D 86.2	
DC Motors	DA 12	
SIMOREG DC MASTER 6RA70 Digital Chassis Converters	DA 21.1	
SIMOREG K 6RA22 Analog Chassis Converters	DA 21.2	
SIMOREG DC MASTER 6RM70 Digital Converter Cabinet Units	DA 22	
SIMOVERT PM Modular Converter Systems	DA 45	
SIEMOSYN Motors	DA 48	
MICROMASTER 410/420/430/440 Inverters	DA 51.2	
MICROMASTER 411/COMBIMASTER 411	DA 51.3	
SIMOVERT MASTERDRIVES Vector Control	DA 65.10	
SIMOVERT MASTERDRIVES Motion Control	DA 65.11	
Synchronous and asynchronous servomotors for SIMOVERT MASTERDRIVES	DA 65.3	
SIMODRIVE 611 universal and POSMO	DA 65.4	
<u>Low-Voltage Three-Phase-Motors</u>		
IEC Squirrel-Cage Motors	D 81.1	
<u>Automation Systems for Machine Tools SIMODRIVE</u>		NC 60
• Main Spindle/Feed Motors		
• Converter Systems SIMODRIVE 611/POSMO		
<u>Automation Systems for Machine Tools SINAMICS</u>		NC 61
• Main Spindle/Feed Motors		
• Drive System SINAMICS S120		
<u>Drive and Control Components for Hoisting Equipment</u>		HE 1
Electrical Installation Technology		
<i>PDF: ALPHA Small Distribution Boards and Distribution Boards, Terminal Blocks</i>	ETA 1	
<i>PDF: ALPHA 8HP Molded-Plastic Distribution System</i>	ETA 3	
BETA Low-Voltage Circuit Protection	ET B1	
<i>PDF: DELTA Switches and Socket Outlets</i>	ET D1	
GAMMA Building Controls	ET G1	
Human Machine Interface Systems SIMATIC HMI		ST 80
Industrial Communication for Automation and Drives		<i>Catalog</i> IK PI
Low-Voltage		
Controls and Distribution – SIRIUS, SENTRON, SIVACON	LV 1	
Controls and Distribution – Technical Information SIRIUS, SENTRON, SIVACON	LV 1 T	
SIDAC Reactors and Filters	LV 60	
SIVENT Fans	LV 65	
SIVACON 8PS Busbar Trunking Systems	LV 70	
Motion Control System SIMOTION		PM 10
Process Instrumentation and Analytics		
Field Instruments for Process Automation	FI 01	
Measuring Instruments for Pressure, Differential Pressure, Flow, Level and Temperature, Positioners and Liquid Meters		
<i>PDF: Indicators for panel mounting</i>	MP 12	
SIREC Recorders and Accessories	MP 20	
SIPART, Controllers and Software	MP 31	
SIWAREX Weighing Systems	WT 01	
Continuous Weighing and Process Protection	WT 02	
Process Analytical Instruments	PA 01	
<i>PDF: Process Analytics, Components for the System Integration</i>	PA 11	
SIMATIC Industrial Automation Systems		
SIMATIC PCS Process Control System	ST 45	
Products for Totally Integrated Automation and Micro Automation	ST 70	
SIMATIC PCS 7 Process Control System	ST PCS 7	
Add-ons for the SIMATIC PCS 7 Process Control System	ST PCS 7.1	
Migration solutions with the SIMATIC PCS 7 Process Control System	ST PCS 7.2	
pc-based Automation	ST PC	
SIMATIC Control Systems	ST DA	
SIMATIC Sensors		FS 10
SIPOS Electric Actuators		
Electric Rotary, Linear and Part-turn Actuators	MP 35	
Electric Rotary Actuators for Nuclear Plants	MP 35.1/2	
Systems Engineering		
Power supplies SITOP power	KT 10.1	
System cabling SIMATIC TOP connect	KT 10.2	
System Solutions		
Applications and Products for Industry are part of the interactive catalog CA 01		
TELEPERM M Process Control System		
<i>PDF: AS 488/TM automation systems</i>	PLT 112	

CD-ROM for Catalog D 21.1

In the CD-ROM that accompanies Catalog D 21.1 · 2006 you will find:

- information about planning/configuring based on the technical documentation; additional technical documentation can be found under:
<http://www.siemens.com/automation/doconweb>
- Dimension drawings of our motors in PDF-/DXF format
- Catalog D 21.1 in electronic form (PDF format)



Hardware and software requirements

- Intel Pentium 333 MHz or higher
- Min. 128 Mbyte RAM
- Screen resolution 1024 x 768 Pixel
- 4 x CD-ROM drive
- Windows 98 SE/NT 4/2000/XP
- Acrobat Reader
- MS Internet Explorer V6.0 (SP2) or higher

Start

Insert the CD-ROM into the CD-ROM drive. The program starts automatically.

If the AutoRun Function is not activated in your system, start file „start.hta“ from the CD-ROM using the Windows Explorer.

Note

Installation is not necessary to view the information on this CD-ROM. This does not apply, however, when using the NCSD configurator or dimension drawings in DXF format.

Hotline

Please send any questions or suggestions to: docu.motioncontrol@siemens.com

www.siemens.com/sinamics

Siemens AG

Automation and Drives
Motion Control Systems
Postfach 31 80
91050 ERLANGEN
GERMANY

www.siemens.com/automation

The information provided in this catalog contains descriptions or characteristics of performance which in case of actual use do not always apply as described or which may change as a result of further development of the products. An obligation to provide the respective characteristics shall only exist if expressly agreed in the terms of contract. Availability and technical specifications are subject to change without notice.

All product designations may be trademarks or product names of Siemens AG or supplier companies whose use by third parties for their own purposes could violate the rights of the owners.

Order No. E86060-K5521-A111-A2-7600